

UNIVERSITY COLLEGE LONDON

University of London

EXAMINATION FOR INTERNAL STUDENTS

For The Following Qualifications:-

B.Eng. M.Eng.

Chemical Eng E853: Process Engineering

COURSE CODE : CENGE853

UNIT VALUE : 0.50

DATE : 30-APR-03

TIME : 14.30

TIME ALLOWED : 2 Hours

Answer **Question 1** and **THREE** other questions from the rest of the paper.
Only the first four answers given will be marked.

ALL questions carry a total of 25 marks each, distributed as shown []

Question 1 should be answered in a separate answer book.

1. An unstable exothermic reaction is being carried out in a reactor protected against a runaway reaction with a cooling water jacket as shown in the figure below. Two independent sensors T1 and T2 continuously monitor the reaction temperature. The cooling water inlet valve V-2 opens automatically when T1 detects a certain increase in temperature. T2 activates an alarm in the control room independently to alert the operator to a possible loss of control of the reaction. When the alarm sounds the operator should press a button to close valve V-1 to stop the reactor feed. When the operator hears the alarm he is also instructed to press the button that opens the quench tank outlet valve in the event that sensor T1 fails to operate. If either valve V-1 closes or V-2 opens the reactor enters a stable shut down without damage to the system.

Construct a *fault tree analysis* for the top event "Reactor damage due to high temperature".

[25]

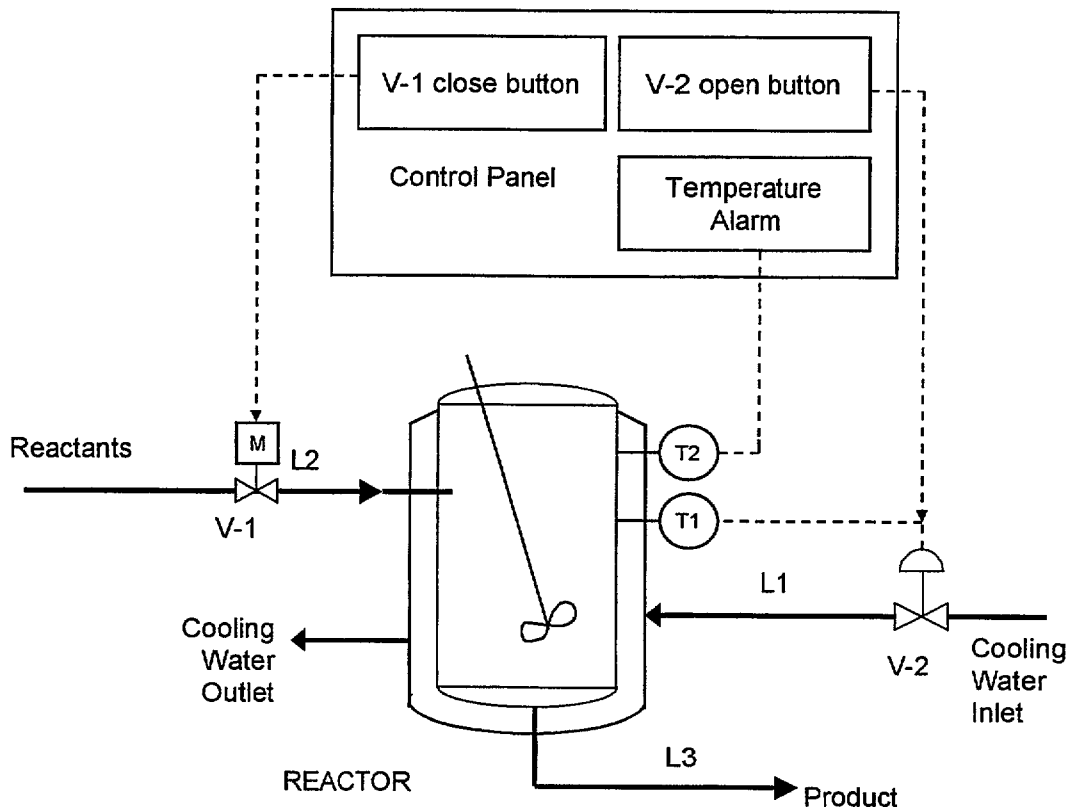

Figure: Question 1

TURN OVER

2. In the design of a process for the production of Chlorobenzene, C_6H_5Cl , with 1 atm boiling point (bp) of 405.2 K, the effluent of the reactor consists of the Chlorobenzene product, Benzene (a reactant, with bp 353.2 K) and two side-products (p- $C_6H_4Cl_2$, bp 447.3 K, and $C_6H_3Cl_3$, bp 486.2 K). Both side-products are considered waste products. Answer the following questions with this process in mind.

a) Describe level 2 of the Douglas hierarchical approach for process synthesis. [10]

b) Having applied level 3 of the Douglas hierarchy to the process, it has been decided that the benzene in the reactor effluent will be recycled. Suggest one reason that would support this decision. [5]

c) You are now asked to apply level 4 of the Douglas hierarchy to this problem. Given the reactor effluent described above with the following flow rates: 100 kmol/h of Chlorobenzene, 300 kmol/h of benzene and 20 kmol/h of each of the side-products, suggest what the first step in the separation section would be, assuming distillation only. Give two reasons to support your suggestion. [10]

3. Consider the following flowsheet with two hot and two cold streams.

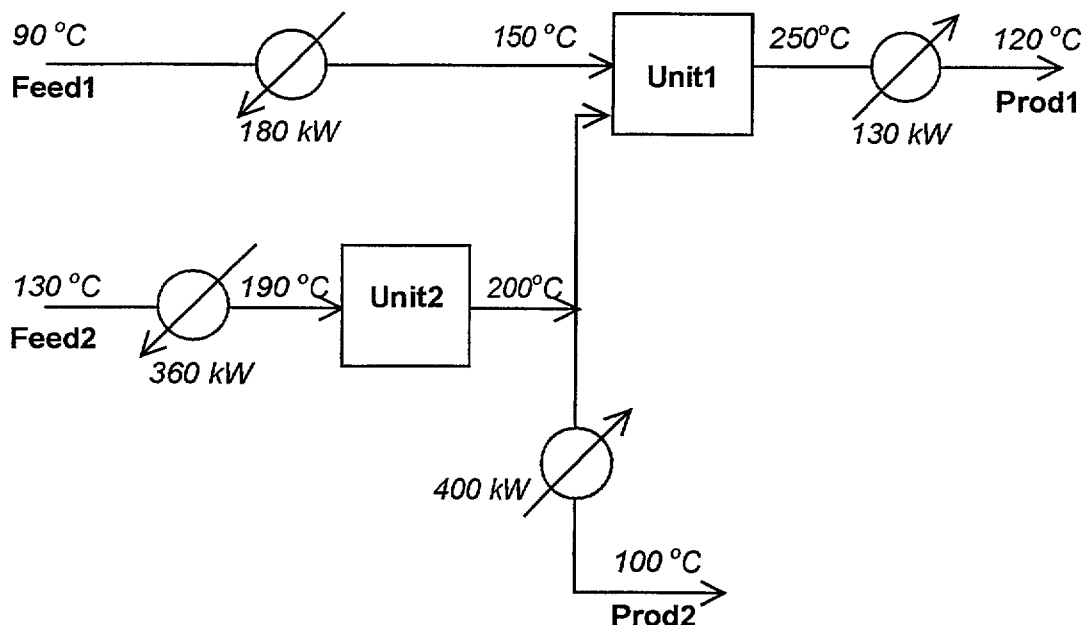

Figure: Question 3

a) Apply the pinch analysis on the system by using a minimum approach temperature of 10 °C to determine the pinch point (temperatures) as well as the minimum heating and cooling loads. [15]

b) Describe a formula that gives the number of units (heat exchangers, heaters and coolers) required to perform all necessary matches of hot and cold streams. [5]

c) During the design stage of a heat-exchanger network, which heuristic design rule do we apply close to the pinch point for feasible stream matches? [5]

CONTINUED

4. a) Define the following:
- (i) Yield strength
 - (ii) Fatigue
 - (iii) Microcrack
 - (iv) Design pressure
 - (v) Thin-walled pressure vessel
- [10]

- b) Prepare brief notes on the features required for the fabrication of a 10 m³ thin-walled pressure vessel to operate at 6 bar (g) pressure, a maximum temperature of 150 °C and to operate in a pH range of 1-6. The contents are to be well mixed and it will be necessary to remove the vessel contents once the reaction is complete. (Sketches may help.)
- [15]

5. a) Define (i) *partitioning* and (ii) *tearing*.
- [8]

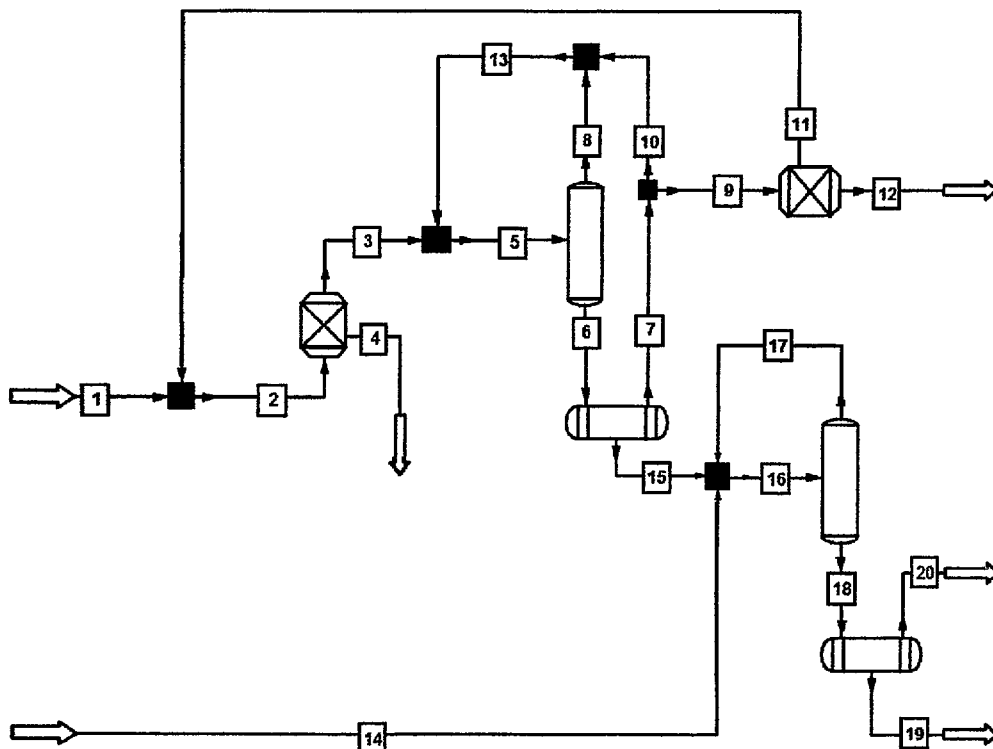

Figure: Question 5, Process Flowsheet

- b) By *inspection* of the process flowsheet above, select a *minimum tear set* consistent with a minimum number of torn streams.
- [8]
- c) Describe briefly the principle of Upadhye and Grens for flowsheet tearing. Suggest an appropriate tear set to give best convergence characteristics for direct substitution.
- [9]
6. Discuss **TWO** of the following:
- a) Recent advances in computer-aided process engineering. [12½]
 - b) Convergence and convergence acceleration in process simulation. [12½]
 - c) Quasi-linear solution methods in process simulation. [12½]

END OF PAPER