

UNIVERSITY COLLEGE LONDON

University of London

EXAMINATION FOR INTERNAL STUDENTS

For The Following Qualification:–

M.Sc.

Biochem Eng G21: Mass, Heat and Momentum Transfer and Bioprocess Material Properties

COURSE CODE : BENGEG21

DATE : 05-MAY-05

TIME : 10.00

TIME ALLOWED : 3 Hours

Answer **FOUR QUESTIONS**. ALL questions carry a total of **25 MARKS** each, distributed as shown []. Only the **FIRST FOUR ANSWERS** will be marked.

1.

- a) You are asked to calibrate the torque scale of a cup-and-bob viscometer with glycerine (viscosity = 0.407 Pa s), before using it to determine the rheology of a fermentation broth. The bob has a radius of 75 mm and rotates concentrically inside the fixed cup. The width of the annular gap is 3mm. Both the cup and bob are 0.15 m long.
Assume the velocity distribution in the gap to be linear.
- i) The viscometer indicates that a torque of 1.25 N m is required to maintain a rotational speed of 180 rpm. Does the torque scale need calibration? [10]
- ii) Determine the power required to maintain a rotational speed of 180rpm. [2]
- b) Many biological fluids are non-Newtonian and their processing is complicated by their rheology. Describe the shear-dependent behaviour of non-Newtonian fluids and sketch the relevant shear stress v. shear rate and apparent viscosity v. shear rate plots. [8]
- c) Describe how you would determine the rheological behaviour of a fermentation broth using a cup-and-bob viscometer. [5]

2.

- a) A hypodermic needle, attached to a syringe, is used to inject a biopharmaceutical drug into a patient.
- i) What type of flow do you expect in the needle? What is the flowrate of the drug most sensitive to? Justify your answer. [4]
- ii) You are given the following data on the syringe and the drug solution:
Needle inside diameter = 0.1 mm
Needle length = 25mm
Plunger diameter = 10 mm
Viscosity of drug solution is five times that of water
Density of drug solution is equal to that of water

Estimate the volumetric flow rate of the biopharmaceutical drug that can be produced using the syringe, given that the maximum force that can be exerted by a thumb on the plunger of the syringe is 45 N. Assume the drug solution is discharged at atmospheric pressure. [6]

Verify your solution and comment on the applicability of the equations used. [4]

PLEASE TURN OVER

- b) You are specifying how to run a fermentation process where pH control is critical to the production of your target product. At the top of the fermenter is an acid addition point for dosing in acid to adjust the pH of the broth. The current design specification is set out below:

Fermenter diameter = 1.5 m

Broth density = 1,000 kg m⁻³

Impeller diameter = 0.4 m

Broth viscosity = 0.01 Pa s

Impeller rotational speed = 15 rpm

What is wrong with the design? How would you re-engineer it and how would you determine if it can be improved?

[11]

3.

You have been asked to help determine the pump requirements in a biopharmaceutical plant. At one point in the process, fermentation medium is pumped from a tank on the ground floor through a 25.4 mm diameter steel pipe to a fermenter at a higher level. The medium flows through a total of 30m of straight pipe with three 90° standard elbows and one gate valve which is ¾ open. The fermentation medium enters the fermenter at an elevation of 10 m above the ground floor. This is illustrated in the schematic below.

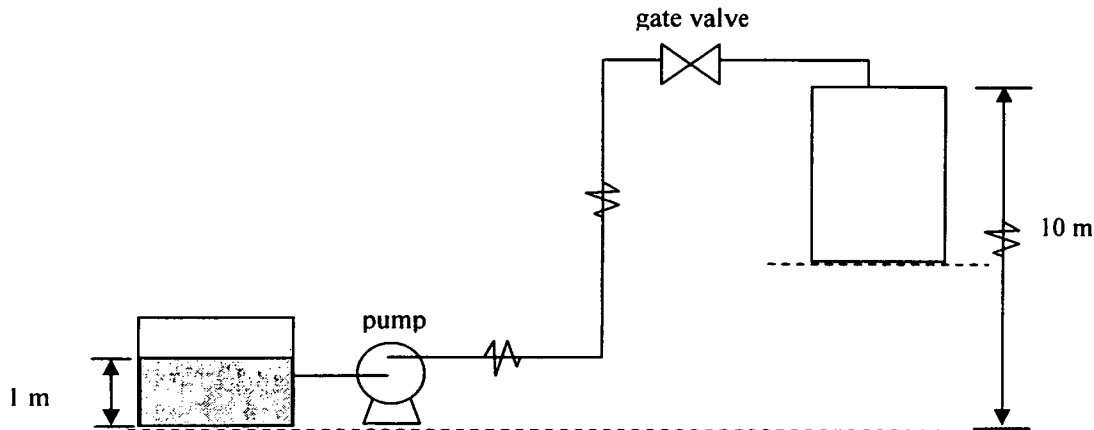

You are given the following data:

Pipe entrance $K = 0.5$

Pipe roughness = 0.046 mm

Pipe exit $K = 1.0$

Medium density = 1000 kg/m³

Gate Valve ¾ open $K = 0.85$

Medium viscosity = 0.0021 Pa s

90° elbow $K = 0.7$

Neglect head losses due to kinetic and pressure energy.

What power must be supplied to the pump? Comment on your answer. [25]

A Moody chart is provided.

CONTINUED

- 4.
- a) State the equations and correlations used in order to estimate the pressure drop in a packed bed. Defend the validity of the assumptions on which these equations are based. [10]
 - b) Using the equations and correlations you have identified above estimate the size of particle that will result in a pressure drop of 2.5 bar. Do you feel that this is an acceptable set of conditions to operate under?

Flowrate: 150 L/h
Column radius: 30 cm
Bed height: 15cm

List any assumptions that you make in addition to those covered in the first part of the question. [15]

- 5.
- a) Discuss the role of impellers in fermenters. [8]
 - b) Discuss the susceptibility of different cell types to damage during mixing and how damage can be reduced, where necessary. [8]
 - c) Describe how the motor power input varies during a fermentation and provide reasons for the variations. [5]
 - d) What are the two most commonly used bases for scale translation in stirred fermenters? What objectives are they based upon? [4]

- 6.
- This question concerns the external diffusional limitations that can occur around an immobilised enzyme during use in biocatalytic processes.
- a) Qualitatively describe external diffusional limitation as defined in the introduction to this question. [5]
 - b) Define the Damkohler number which is used to characterise the diffusional limitations at a given substrate concentration. [5]
 - c) Define the Michaelis-Menten expression. [5]
 - d) Explain why the effectiveness factor decreases as the Damkohler number increases. [5]
 - e) How might the Damkohler number be reduced from a practical standpoint. [5]

PLEASE TURN OVER

CHART FOR Q3

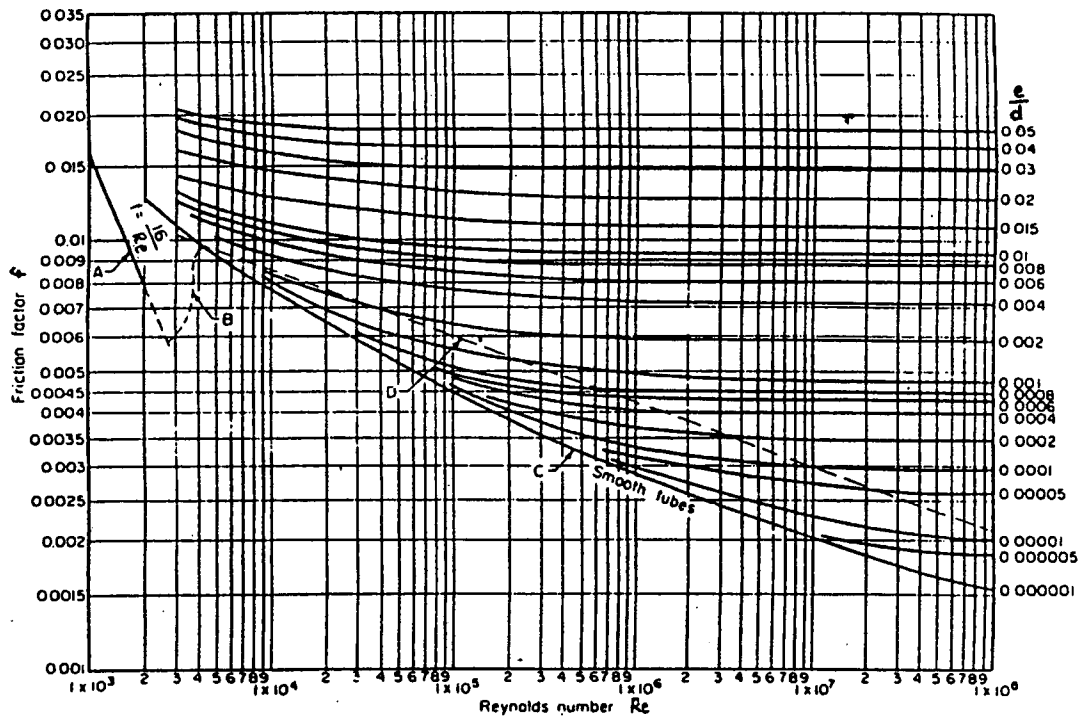

Figure 1. Moody chart

END OF PAPER