

**UNIVERSITY COLLEGE LONDON**

University of London

**EXAMINATION FOR INTERNAL STUDENTS**

For The Following Qualification:–

*M.Sc.*

**Biochem Eng G20: Bioprocess Engineering Design and Regulatory Constraints**

COURSE CODE : **BENGE20**

DATE : **10-MAY-04**

TIME : **14.30**

TIME ALLOWED : **2 Hours**

*Answer Question 1 and THREE other questions from the rest of the paper.  
Only the first four answers given will be marked.*

*ALL questions carry a total of 25 marks each, distributed as shown [ ]*

1. Define the two words 'HAZARD' and 'RISK' [6]  
Give three examples of a hazard. [3]  
Describe the steps to be carried out in a risk assessment of a task. [16]

2. Consider the design of a heat-exchanger network with two cold and two hot streams with the following data:

| Stream Number | Q (kW) | T <sub>in</sub> (K) | T <sub>out</sub> (K) |
|---------------|--------|---------------------|----------------------|
| 1             | 2800   | 650                 | 370                  |
| 2             | 4400   | 590                 | 370                  |
| 3             | 3600   | 410                 | 650                  |
| 4             | 1950   | 350                 | 500                  |

Assume that steam and cooling water are available at appropriate temperature levels.

Apply the pinch analysis on the system by using a minimum approach temperature of 10 °C to determine the pinch point temperatures as well as the minimum heating and cooling loads. [15]

Design an appropriate process heat exchanger (inlet and outlet temperatures and amount of heat exchanged) above the pinch, justifying carefully why such an exchanger is possible and how the quantities are determined. [10]

**PLEASE TURN OVER**

3. A construction project is defined by the list of activities in the following table:

| Activity | Duration (days) | Prerequisites | Workers required |
|----------|-----------------|---------------|------------------|
| A        | 3               | None          | 2                |
| B        | 4               | None          | 1                |
| C        | 3               | None          | 1                |
| D        | 2               | C             | 1                |
| E        | 1               | B             | 2                |
| F        | 5               | A             | 1                |
| G        | 2               | B             | 2                |
| H        | 3               | B             | 1                |
| I        | 11              | C             | 1                |
| J        | 3               | D, E          | 0                |
| K        | 1               | F, G          | 1                |
| L        | 4               | K             | 1                |
| M        | 4               | J, H          | 1                |

- a) Draw the activity-on-node diagram for the above project. [5]
- b) What is the earliest completion time for the above project provided that an unlimited number of workers are available during the project? Which activities lie on the critical path? [12]
- c) Based on the activities' earliest starting times, draw the time chart (Gantt chart) of all the activities in the project as well as the utilisation profile of the workers over the duration of the project. [5]
- d) What effect would a 2-day delay in activity D have on the overall project completion time? [3]
4. Answer ALL parts of this question.
- a) Why does fatigue occur in materials of construction? Giving the example of an artificial heart valve what criteria do you think it would be necessary to establish when designing and fabricating such an item? [5]
- b) The failure of the Liberty ship construction is an example of what mode of breakage? How could it have been avoided? [5]
- c) Under what process conditions do you believe that creep is a relevant factor? [5]
- d) What properties do stainless steels possess that make them a natural choice for use in the biological process industries? Note at least one major exception to this rule. [5]
- e) When measuring materials' properties in tensile tests it is assumed that the cross sectional area of the sample is constant. Why is this strictly not valid and how will it affect the measured properties of the sample? [5]

**CONTINUED**

5. Compare and contrast the principles behind *sequential-modular* and *simultaneous equation-based* process flowsheeting simulation methods. [10]

Draw up

- a) a *process matrix*, [4]  
 b) a *signal flowgraph*, and [4]  
 c) the *stream precursors list* [3]

representing the process flowsheet given below where the unit numbers are shown in circles and the stream numbers in rectangles. Note, the condenser and reboiler associated with unit ④ are to be considered as an integral part of that unit.

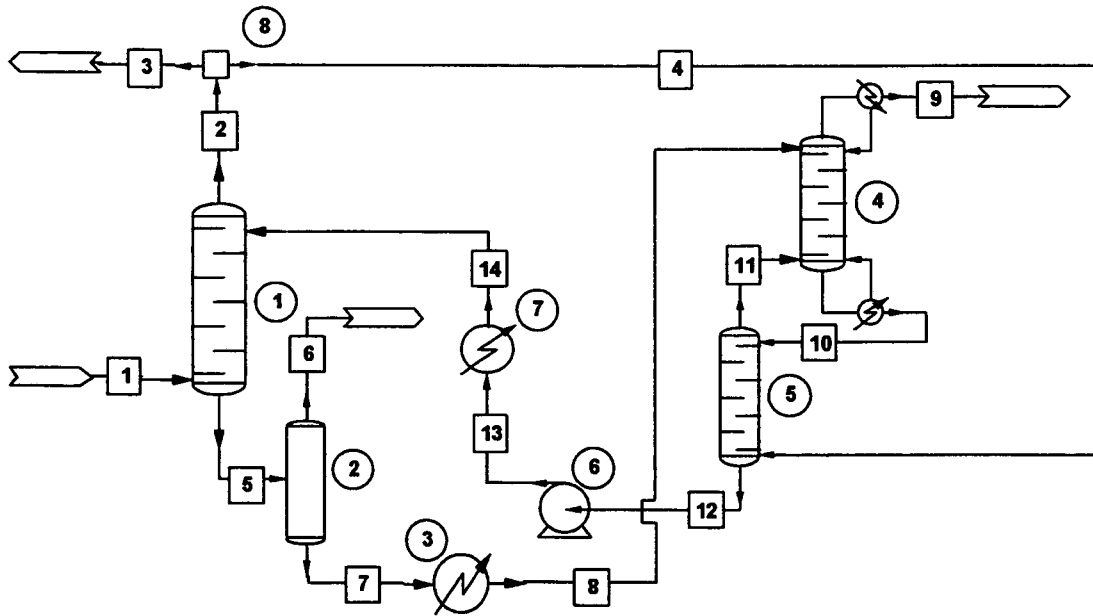

**Question 5: Process flowsheet**

By inspection of your signal flowgraph, select a *minimum tear set* consistent with a minimum number of torn streams. [4]

6. Discuss **TWO** of the following in the context of process simulation:
- a) The incorporation of batch and semi-batch unit operations into steady state process simulators. [12½]  
 b) 'Design' versus 'Simulation'. [12½]  
 c) Recycles and recycle convergence. [12½]

**END OF PAPER**