

# **University College London**

**Department of Computer Science**

**VIVE MSc Multimedia Systems**

Jon Crowcroft and Vicky Hardman and Saleem Bhatti

## **EXAMINATION QUESTIONS**

NEXT PAGE LEFT BLANK FOR RUBRIC

### **QUESTION 1**

a) Explain the components of H.261 or MPEG Like video compression system

**[10 marks]**

b) What would zooming do to the picture quality or data rate?

**[10 marks]**

c) Why does panning have a less severe effect on the picture quality than zooming?

**[5 marks]**

**[Total 25 marks]**

## QUESTION 2

a) Explain with the aid of diagrams, how RTP is used to provide inter and intra stream synchronisation? **[15 marks]**

c) Why do you need synchronised clocks to provide absolute fidelity for playback?

**[5 marks]**

c) What special synchronisation might be needed for a multi-sender application such as a networked game? **[5 marks]**

**[Total 25 marks]**

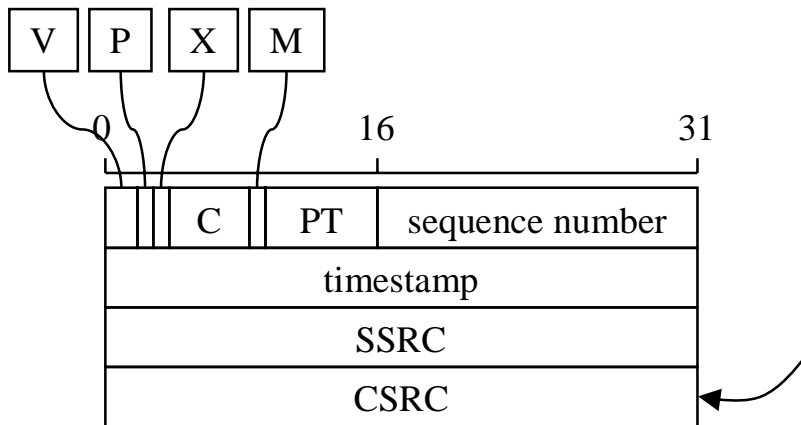

**QUESTION 3**

You work for a company that wishes to become a Voice over IP (Internet Protocol) provider. You have been asked to write a technical report that includes the following:-

- a) Background material on LPC and analysis-by-synthesis codecs. Include in your answer a diagram for each codec, and an explanation of the deficiencies of LPC and how these are improved upon by analysis-by-synthesis codecs. **[9 marks]**

- b) Calculation of the bit-rates for the following codecs is given: -

ADPCM G.721, sampling rate = 8000 samples per second, bits per codeword = 4.

CS-ACELP G.729 frame size = 10ms, LP coefficients = 18 bits, excitation information = 62 bits.

**[6 marks]**

- c) Write some technical input for a business case for two possible VOIP solutions, a PC-based solution, and a phone-based solution. Your input should focus on delay and loss issues. Assume that the PC-based solution consists of software running on a user's general purpose PC that would use a range of existing audio cards. Assume that the phone-based solution consists of a proprietary server that connects to multiple normal phone lines. Include in your answer a discussion of which of the ADPCM or G.729 codecs you would recommend for each scenario. **[10 marks]**

**[Total 25 marks]**

### Question 4

You work for a company called 'Piratester', and are considering launching some software that will allow users to share music tracks with each other from their hard disks across the Internet. To evaluate the likely success of your software write a technical report that describes: -

- a) Background information on the ADPCM and the MPEG1 Layer 3 music compression algorithms **[9 marks]**

- b) Calculate the bandwidth required by a real-time transmission of 'Imagine' for each type of codec if: -

ADPCM for music has a sampling frequency of 16,000Hz, and 4 bits per code word, and packet sizes of 160ms worth of music. RTP headers are 40 bytes long.

MPEG1 L3 has a sampling rate of 48,000 bits per second, number of bits per sample = 16. Assume that MPEG1 L3 and IP / RTP headers contribute an increase in the bandwidth of 10%. **[6 marks]**

- c) Contrast the expected quality of the two transmissions over the Internet – one coded using ADPCM and one coded using MPEG1 Layer 3 compression. Assume that the ADPCM coded speech is streamed, whilst the MPEG1 layer 3 music is sent as files. Consider first that there is no loss, and secondly that there is a low rate of IP packet loss experienced over the network. **[10 marks]**

**[Total 25 marks]**

**Question 5.**

a) TCP already has a sophisticated congestion control and avoidance scheme. However, Explicit Congestion Notification (ECN) is being proposed to enhance this existing scheme. Give a description of the existing scheme of **slow-start** and **congestion avoidance** and say how ECN would improve on it. Your answer should include a note of the role of network routers in both the normal and the ECN schemes.

**[15 marks]**

b) *While ECN may seem a useful scheme to use for TCP traffic, it may not be suitable for real-time traffic.*

Assuming you are working within a best-effort network only, give explanations for this statement, highlighting:

i) Why ECN would be useful for real-time applications.

ii) The difficulties that might be faced by real-time applications when trying to use ECN.

**[10 marks]**

**[Total 25 marks]**

**Question 6**

**a)** Outline the main components of a QoS Routing Architecture.

[10 marks]

**b)** Give a brief overview of the mechanisms that the Protocol Independent Multicast routing protocol provides for Multicast.

[10 marks]

**c)** Speculate on what might be done to support a network service that combined together the requirements for QoS Routing and Multicast Routing.

[5 marks]

[Total 25 marks]