

*Handbook of Mathematics, Physics and  
Astronomy Data*

School of Physical and Geographical Sciences  
University of Keele



Keele  
University

©2013

# Contents

<b>1</b>	<b>Reference Data</b>	<b>1</b>
1.1	Physical Constants . . . . .	2
1.2	Astrophysical Quantities . . . . .	3
1.3	Periodic Table . . . . .	4
1.4	Electron Configurations of the Elements . . . . .	5
1.5	Greek Alphabet and SI Prefixes . . . . .	6
<b>2</b>	<b>Mathematics</b>	<b>7</b>
2.1	Mathematical Constants and Notation . . . . .	8
2.2	Algebra . . . . .	9
2.3	Trigonometrical Identities . . . . .	10
2.4	Hyperbolic Functions . . . . .	12
2.5	Differentiation . . . . .	13
2.6	Standard Derivatives . . . . .	14
2.7	Integration . . . . .	15
2.8	Standard Indefinite Integrals . . . . .	16
2.9	Definite Integrals . . . . .	18
2.10	Curvilinear Coordinate Systems . . . . .	19
2.11	Vectors and Vector Algebra . . . . .	22
2.12	Complex Numbers . . . . .	25
2.13	Series . . . . .	27
2.14	Ordinary Differential Equations . . . . .	30
2.15	Partial Differentiation . . . . .	33
2.16	Partial Differential Equations . . . . .	35
2.17	Determinants and Matrices . . . . .	36
2.18	Vector Calculus . . . . .	39
2.19	Fourier Series . . . . .	42
2.20	Statistics . . . . .	45
<b>3</b>	<b>Selected Physics Formulae</b>	<b>47</b>
3.1	Equations of Electromagnetism . . . . .	48
3.2	Equations of Relativistic Kinematics and Mechanics . . . . .	49
3.3	Thermodynamics and Statistical Physics . . . . .	50

---

# Reference Data

---

1.1	Physical Constants . . . . .	2
1.2	Astrophysical Quantities . . . . .	3
1.3	Periodic Table . . . . .	4
1.4	Electron Configurations of the Elements . . . . .	5
1.5	Greek Alphabet and SI Prefixes . . . . .	6

## 1.1 Physical Constants

Symbol	Quantity	Value
$c$	Speed of light in free space	$2.998 \times 10^8 \text{ m s}^{-1}$
$h$	Planck constant	$6.626 \times 10^{-34} \text{ J s}$
$\hbar$	$h/2\pi$	$1.055 \times 10^{-34} \text{ J s}$
$G$	Universal gravitation constant	$6.674 \times 10^{-11} \text{ N m}^2 \text{ kg}^{-2}$
$e$	Electron charge	$1.602 \times 10^{-19} \text{ C}$
$m_e$	Electron rest mass	$9.109 \times 10^{-31} \text{ kg}$
$m_p$	Proton rest mass	$1.673 \times 10^{-27} \text{ kg}$
$m_n$	Neutron rest mass	$1.675 \times 10^{-27} \text{ kg}$
$u$	Atomic mass unit	$(\frac{1}{12} \text{ mass of } ^{12}\text{C})$ $= 1.661 \times 10^{-27} \text{ kg}$
$N_A$	Avogadro's constant	$6.022 \times 10^{23} \text{ mol}^{-1}$ $= 6.022 \times 10^{26} (\text{kg-mole})^{-1}$
$k_B$	Boltzmann constant	$1.381 \times 10^{-23} \text{ J K}^{-1}$
$R$	Gas constant = $Nk$	$8.314 \times 10^3 \text{ J K}^{-1} (\text{kg-mole})^{-1}$ $8.314 \text{ J K}^{-1} \text{ mol}^{-1}$
$\mu_B$	Bohr magneton	$9.274 \times 10^{-24} \text{ J T}^{-1}$ (or $\text{A m}^2$ )
$\mu_N$	Nuclear magneton	$5.051 \times 10^{-27} \text{ J T}^{-1}$
$R_\infty$	Rydberg constant	$10973732 \text{ m}^{-1}$
$a_0$	Bohr radius	$5.292 \times 10^{-11} \text{ m}$
$\sigma$	Stefan-Boltzmann constant	$5.670 \times 10^{-8} \text{ J K}^{-4} \text{ m}^{-2} \text{ s}^{-1}$
$\alpha$	Fine structure constant	$1/137.04$
$\sigma_T$	Thomson cross-section	$6.652 \times 10^{-29} \text{ m}^2$
$\mu_0$	Permeability of free space	$4\pi \times 10^{-7} \text{ H m}^{-1}$
$\epsilon_0$	Permittivity of free space	$1/(\mu_0 c^2)$ $= 8.854 \times 10^{-12} \text{ F m}^{-1}$
eV	Electron volt	$1.602 \times 10^{-19} \text{ J}$
g	Standard acceleration of gravity	$9.807 \text{ m s}^{-2}$
atm	Standard atmosphere	$101325 \text{ N m}^{-2} = 101325 \text{ Pa}$

## 1.2 Astrophysical Quantities

Symbol	Quantity	Value
$M_{\odot}$	Mass of Sun	$1.989 \times 10^{30}$ kg
$R_{\odot}$	Radius of Sun	$6.955 \times 10^8$ m
$L_{\odot}$	Bolometric luminosity of Sun	$3.846 \times 10^{26}$ W
$M_{\text{bol}}^{\odot}$	Absolute bolometric magnitude of Sun	+4.75
$M_{\text{vis}}^{\odot}$	Absolute visual magnitude of Sun	+4.83
$T_{\odot}$	Effective temperature of Sun	5778 K
	Spectral type of Sun	G2 V
$M_{\text{J}}$	Mass of Jupiter	$1.899 \times 10^{27}$ kg
$R_{\text{J}}$	Equatorial radius of Jupiter	71492 km
$M_{\oplus}$	Mass of Earth	$5.974 \times 10^{24}$ kg
$R_{\oplus}$	Equatorial radius of Earth	6378 km
$M_{\zeta}$	Mass of Moon	$7.348 \times 10^{22}$ kg
$R_{\zeta}$	Equatorial radius of Moon	1738 km
	Sidereal year	$3.156 \times 10^7$ s
AU	Astronomical Unit	$1.496 \times 10^{11}$ m
ly	Light year	$9.461 \times 10^{15}$ m
pc	Parsec	$3.086 \times 10^{16}$ m
Jy	Jansky	$10^{-26}$ W m <sup>-2</sup> Hz <sup>-1</sup>
$H_0$	Hubble constant	$72 \pm 5$ km s <sup>-1</sup> Mpc <sup>-1</sup>



## 1.4 Electron Configurations of the Elements

Z	Element	Electron configuration													
		1s	2s	2p	3s	3p	3d	4s	4p	4d	4f	5s	5p	5d	5f
1	H	1													
2	He	2													
3	Li	2	1												
4	Be	2	2												
5	B	2	2	1											
6	C	2	2	2											
7	N	2	2	3											
8	O	2	2	4											
9	F	2	2	5											
10	Ne	2	2	6											
11	Na	2	2	6	1										
12	Mg	2	2	6	2										
13	Al	2	2	6	2	1									
14	Si	2	2	6	2	2									
15	P	2	2	6	2	3									
16	S	2	2	6	2	4									
17	Cl	2	2	6	2	5									
18	Ar	2	2	6	2	6									
19	K	2	2	6	2	6	-	1							
20	Ca	2	2	6	2	6	-	2							
21	Sc	2	2	6	2	6	1	2							
22	Ti	2	2	6	2	6	2	2							
23	V	2	2	6	2	6	3	2							
24	Cr	2	2	6	2	6	5	1							
25	Mn	2	2	6	2	6	5	2							
26	Fe	2	2	6	2	6	6	2							
27	Co	2	2	6	2	6	7	2							
28	Ni	2	2	6	2	6	8	2							
29	Cu	2	2	6	2	6	10	1							
30	Zn	2	2	6	2	6	10	2							
31	Ga	2	2	6	2	6	10	2	1						
32	Ge	2	2	6	2	6	10	2	2						
33	As	2	2	6	2	6	10	2	3						
34	Se	2	2	6	2	6	10	2	4						
35	Br	2	2	6	2	6	10	2	5						
36	Kr	2	2	6	2	6	10	2	6						
37	Rb	2	2	6	2	6	10	2	6	-	-	1			
38	Sr	2	2	6	2	6	10	2	6	-	-	2			
39	Y	2	2	6	2	6	10	2	6	1	-	2			
40	Zr	2	2	6	2	6	10	2	6	2	-	2			
41	Nb	2	2	6	2	6	10	2	6	4	-	1			
42	Mo	2	2	6	2	6	10	2	6	5	-	1			
43	Tc	2	2	6	2	6	10	2	6	6	-	1			
44	Ru	2	2	6	2	6	10	2	6	7	-	1			
45	Rh	2	2	6	2	6	10	2	6	8	-	1			
46	Pd	2	2	6	2	6	10	2	6	10	-	-			
47	Ag	2	2	6	2	6	10	2	6	10	-	1			
48	Cd	2	2	6	2	6	10	2	6	10	-	2			
49	In	2	2	6	2	6	10	2	6	10	-	2	1		
50	Sn	2	2	6	2	6	10	2	6	10	-	2	2		
51	Sb	2	2	6	2	6	10	2	6	10	-	2	3		
52	Te	2	2	6	2	6	10	2	6	10	-	2	4		
53	I	2	2	6	2	6	10	2	6	10	-	2	5		
54	Xe	2	2	6	2	6	10	2	6	10	-	2	6		

## 1.5 Greek Alphabet and SI Prefixes

### The Greek alphabet

A	$\alpha$	alpha	N	$\nu$	nu
B	$\beta$	beta	$\Xi$	$\xi$	xi
$\Gamma$	$\gamma$	gamma	O	o	omicron
$\Delta$	$\delta$	delta	$\Pi$	$\pi$	pi
E	$\epsilon, \varepsilon$	epsilon	P	$\rho, \varrho$	rho
Z	$\zeta$	zeta	$\Sigma$	$\sigma, \varsigma$	sigma
H	$\eta$	eta	T	$\tau$	tau
$\Theta$	$\theta, \vartheta$	theta	Y	$\upsilon$	upsilon
I	$\iota$	iota	$\Phi$	$\phi, \varphi$	phi
K	$\kappa$	kappa	X	$\chi$	chi
$\Lambda$	$\lambda$	lambda	$\Psi$	$\psi$	psi
M	$\mu$	mu	$\Omega$	$\omega$	omega

### SI Prefixes

Name	Prefix	Factor
yotta	Y	$10^{24}$
zetta	Z	$10^{21}$
exa	E	$10^{18}$
peta	P	$10^{15}$
tera	T	$10^{12}$
giga	G	$10^9$
mega	M	$10^6$
kilo	k	$10^3$
hecto	h	$10^2$
deca	da	$10^1$
deci	d	$10^{-1}$
centi	c	$10^{-2}$
milli	m	$10^{-3}$
micro	$\mu$	$10^{-6}$
nano	n	$10^{-9}$
pico	p	$10^{-12}$
femto	f	$10^{-15}$
atto	a	$10^{-18}$
zepto	z	$10^{-21}$
yocto	y	$10^{-24}$



---

# Mathematics

---

2.1	Mathematical Constants and Notation . . . . .	8
2.2	Algebra . . . . .	9
2.3	Trigonometrical Identities . . . . .	10
2.4	Hyperbolic Functions . . . . .	12
2.5	Differentiation . . . . .	13
2.6	Standard Derivatives . . . . .	14
2.7	Integration . . . . .	15
2.8	Standard Indefinite Integrals . . . . .	16
2.9	Definite Integrals . . . . .	18
2.10	Curvilinear Coordinate Systems . . . . .	19
2.11	Vectors and Vector Algebra . . . . .	22
2.12	Complex Numbers . . . . .	25
2.13	Series . . . . .	27
2.14	Ordinary Differential Equations . . . . .	30
2.15	Partial Differentiation . . . . .	33
2.16	Partial Differential Equations . . . . .	35
2.17	Determinants and Matrices . . . . .	36
2.18	Vector Calculus . . . . .	39
2.19	Fourier Series . . . . .	42
2.20	Statistics . . . . .	45

## 2.1 Mathematical Constants and Notation

### Constants

$$\begin{aligned}\pi &= 3.141592654\dots && (\text{N.B. } \pi^2 \simeq 10) \\ e &= 2.718281828\dots \\ \ln 10 &= 2.302585093\dots \\ \log_{10} e &= 0.434294481\dots \\ \ln x &= 2.302585093 \log_{10} x \\ 1 \text{ radian} &= 180/\pi \simeq 57.2958 \text{ degrees} \\ 1 \text{ degree} &= \pi/180 \simeq 0.0174533 \text{ radians}\end{aligned}$$

### Notation

$$\begin{aligned}\text{Factorial } n = n! &= n \times (n-1) \times (n-2) \times \dots \times 2 \times 1 \\ &(\text{N.B. } 0! = 1)\end{aligned}$$

$$\begin{aligned}\text{STIRLING'S APPROXIMATION} \quad n! &\simeq \left(\frac{n}{e}\right)^n (2\pi n)^{1/2} \quad (n \gg 1) \\ \ln n! &\simeq n \ln n - n \quad (\text{Error } \lesssim 4\% \text{ for } n \geq 15)\end{aligned}$$

$$\text{Double Factorial } n!! = \begin{cases} n \times (n-2) \times \dots \times 5 \times 3 \times 1 & \text{for } n > 0 \text{ odd} \\ n \times (n-2) \times \dots \times 6 \times 4 \times 2 & \text{for } n > 0 \text{ even} \\ 1 & \text{for } n = -1, 0 \end{cases}$$

$$\begin{aligned}\exp(x) &= e^x \\ \ln x &= \log_e x \\ \arcsin x &= \sin^{-1} x \\ \arccos x &= \cos^{-1} x \\ \arctan x &= \tan^{-1} x \\ \sum_{i=1}^n A_i &= A_1 + A_2 + A_3 + \dots + A_n = \text{sum of } n \text{ terms} \\ \prod_{i=1}^n A_i &= A_1 \times A_2 \times A_3 \times \dots \times A_n = \text{product of } n \text{ terms}\end{aligned}$$

$$\text{Sign function: } \operatorname{sgn} x = \begin{cases} +1 & \text{if } x > 0 \\ 0 & \text{if } x = 0 \\ -1 & \text{if } x < 0 \end{cases}$$

## 2.2 Algebra

### Polynomial expansions

$$(a + b)^2 = a^2 + 2ab + b^2$$

$$(ax + b)^2 = a^2x^2 + 2abx + b^2$$

$$(a + b)^3 = a^3 + 3a^2b + 3ab^2 + b^3$$

$$(ax + b)^3 = a^3x^3 + 3a^2bx^2 + 3ab^2x + b^3$$

### Quadratic equations

$$ax^2 + bx + c = 0$$

$$x = \frac{-b \pm \sqrt{b^2 - 4ac}}{2a}$$

### Logarithms and Exponentials

$$\text{If } y = a^x \quad \text{then} \quad y = e^{x \ln a} \quad \text{and} \quad \log_a y = x$$

$$a^0 = 1$$

$$a^{-x} = 1/a^x$$

$$a^x \times a^y = a^{x+y}$$

$$a^x/a^y = a^{x-y}$$

$$(a^x)^y = (a^y)^x = a^{xy}$$

$$\ln 1 = 0$$

$$\ln(1/x) = -\ln x$$

$$\ln(xy) = \ln x + \ln y$$

$$\ln(x/y) = \ln x - \ln y$$

$$\ln x^y = y \ln x$$

$$\text{Change of base: } \log_a y = \frac{\log_b y}{\log_b a}$$

$$\text{and in particular } \ln y = \frac{\log_{10} y}{\log_{10} e} \simeq 2.303 \log_{10} y$$

## 2.3 Trigonometrical Identities

### Trigonometric functions

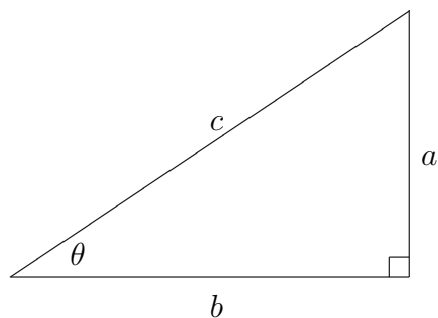

$$\sin \theta = \frac{a}{c} \quad \cos \theta = \frac{b}{c} \quad \tan \theta = \frac{a}{b}$$

$$\csc \theta = \frac{1}{\sin \theta} \quad \sec \theta = \frac{1}{\cos \theta} \quad \cot \theta = \frac{1}{\tan \theta}$$

### Basic relations

$$\begin{aligned} (\sin \theta)^2 + (\cos \theta)^2 &\equiv \sin^2 \theta + \cos^2 \theta = 1 \\ 1 + \tan^2 \theta &= \sec^2 \theta \\ 1 + \cot^2 \theta &= \csc^2 \theta \\ \frac{\sin \theta}{\cos \theta} &= \tan \theta \end{aligned}$$

### Sine and Cosine Rules

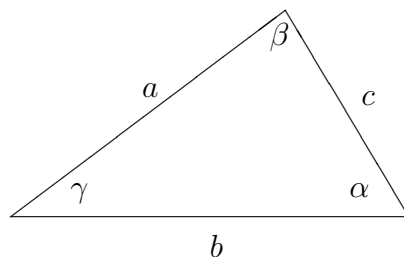

SINE RULE  $\frac{a}{\sin \alpha} = \frac{b}{\sin \beta} = \frac{c}{\sin \gamma}$

COSINE RULE  $a^2 = b^2 + c^2 - 2bc \cos \alpha$

## Expansions for compound angles

$$\sin(A + B) = \sin A \cos B + \cos A \sin B$$

$$\sin(A - B) = \sin A \cos B - \cos A \sin B$$

$$\cos(A + B) = \cos A \cos B - \sin A \sin B$$

$$\cos(A - B) = \cos A \cos B + \sin A \sin B$$

$$\tan(A + B) = \frac{\tan A + \tan B}{1 - \tan A \tan B}$$

$$\tan(A - B) = \frac{\tan A - \tan B}{1 + \tan A \tan B}$$

$$\sin\left(\theta + \frac{\pi}{2}\right) = +\cos \theta \qquad \sin\left(\frac{\pi}{2} - \theta\right) = +\cos \theta$$

$$\cos\left(\theta + \frac{\pi}{2}\right) = -\sin \theta \qquad \cos\left(\frac{\pi}{2} - \theta\right) = +\sin \theta$$

$$\sin(\pi + \theta) = -\sin \theta \qquad \sin(\pi - \theta) = +\sin \theta$$

$$\cos(\pi + \theta) = -\cos \theta \qquad \cos(\pi - \theta) = -\cos \theta$$

$$\cos A \cos B = \frac{1}{2}[\cos(A + B) + \cos(A - B)]$$

$$\sin A \sin B = \frac{1}{2}[\cos(A - B) - \cos(A + B)]$$

$$\sin A \cos B = \frac{1}{2}[\sin(A + B) + \sin(A - B)]$$

$$\cos A \sin B = \frac{1}{2}[\sin(A + B) - \sin(A - B)]$$

$$\sin 2A = 2 \sin A \cos A$$

$$\cos 2A = \cos^2 A - \sin^2 A = 2 \cos^2 A - 1$$

$$= 1 - 2 \sin^2 A$$

$$\tan 2A = \frac{2 \tan A}{1 - \tan^2 A}$$

## Factor formulae

$$\sin A + \sin B = +2 \sin\left(\frac{A + B}{2}\right) \cos\left(\frac{A - B}{2}\right)$$

$$\sin A - \sin B = +2 \cos\left(\frac{A + B}{2}\right) \sin\left(\frac{A - B}{2}\right)$$

$$\cos A + \cos B = +2 \cos\left(\frac{A + B}{2}\right) \cos\left(\frac{A - B}{2}\right)$$

$$\cos A - \cos B = -2 \sin\left(\frac{A + B}{2}\right) \sin\left(\frac{A - B}{2}\right)$$

## 2.4 Hyperbolic Functions

### Definitions and basic relations

$$\begin{aligned}\sinh x &= \frac{e^x - e^{-x}}{2} \\ \cosh x &= \frac{e^x + e^{-x}}{2} \\ \tanh x &= \frac{\sinh x}{\cosh x} = \frac{e^{2x} - 1}{e^{2x} + 1}\end{aligned}$$

$$\begin{aligned}\operatorname{sech} x &= 1/\cosh x & \cosh^2 x - \sinh^2 x &= 1 \\ \operatorname{cosech} x &= 1/\sinh x & 1 - \tanh^2 x &= \operatorname{sech}^2 x \\ \operatorname{coth} x &= 1/\tanh x & \operatorname{coth}^2 x - 1 &= \operatorname{cosech}^2 x\end{aligned}$$

$$\begin{aligned}\sinh^{-1} x &= \log_e[x + \sqrt{x^2 + 1}] \\ \cosh^{-1} x &= \pm \log_e[x + \sqrt{x^2 - 1}] \\ \tanh^{-1} x &= \frac{1}{2} \log_e \left( \frac{1+x}{1-x} \right) \quad (x^2 < 1)\end{aligned}$$

### Expansions for compound arguments

$$\begin{aligned}\sinh(A \pm B) &= \sinh A \cosh B \pm \cosh A \sinh B \\ \cosh(A \pm B) &= \cosh A \cosh B \pm \sinh A \sinh B \\ \tanh(A \pm B) &= \frac{\tanh A \pm \tanh B}{1 \pm \tanh A \tanh B} \\ \sinh 2A &= 2 \sinh A \cosh A \\ \cosh 2A &= \cosh^2 A + \sinh^2 A = 2 \cosh^2 A - 1 = 1 + 2 \sinh^2 A \\ \tanh 2A &= \frac{2 \tanh A}{1 + \tanh^2 A}\end{aligned}$$

### Factor formulae

$$\begin{aligned}\sinh A + \sinh B &= 2 \sinh \left( \frac{A+B}{2} \right) \cosh \left( \frac{A-B}{2} \right) \\ \sinh A - \sinh B &= 2 \cosh \left( \frac{A+B}{2} \right) \sinh \left( \frac{A-B}{2} \right) \\ \cosh A + \cosh B &= 2 \cosh \left( \frac{A+B}{2} \right) \cosh \left( \frac{A-B}{2} \right) \\ \cosh A - \cosh B &= 2 \sinh \left( \frac{A+B}{2} \right) \sinh \left( \frac{A-B}{2} \right)\end{aligned}$$

## 2.5 Differentiation

### Definition

$$f'(x) \equiv \frac{d}{dx} f(x) = \lim_{\delta x \rightarrow 0} \left[ \frac{f(x + \delta x) - f(x)}{\delta x} \right]$$

$$f''(x) \equiv \frac{d^2}{dx^2} f(x) = \frac{d}{dx} f'(x)$$

$$f^n(x) \equiv \frac{d^n}{dx^n} f(x) = \text{the } n^{\text{th}} \text{ order differential,}$$

obtained by taking  $n$  successive differentiations of  $f(x)$ .

The overdot notation is often used to indicate a derivative taken with respect to time:

$$\dot{y} \equiv \frac{dy}{dt}, \quad \ddot{y} \equiv \frac{d^2y}{dt^2}, \quad \text{etc.}$$

### Rules of differentiation

If  $u = u(x)$  and  $v = v(x)$  then:

SUM RULE  $\quad \frac{d}{dx} (u + v) = \frac{du}{dx} + \frac{dv}{dx}$

FACTOR RULE  $\quad \frac{d}{dx} (ku) = k \frac{du}{dx}$  where  $k$  is any constant

PRODUCT RULE  $\quad \frac{d}{dx} (uv) = u \frac{dv}{dx} + v \frac{du}{dx}$

QUOTIENT RULE  $\quad \frac{d}{dx} \left( \frac{u}{v} \right) = \left( v \frac{du}{dx} - u \frac{dv}{dx} \right) / v^2$

CHAIN RULE  $\quad \frac{dy}{dx} = \frac{dy}{du} \times \frac{du}{dx}$

### Leibnitz' formula

Leibnitz' formula for the  $n^{\text{th}}$  derivative of a product of two functions  $u(x)$  and  $v(x)$ :

$$[uv]_n = u_n v + n u_{n-1} v_1 + \frac{n(n-1)}{2!} u_{n-2} v_2 + \frac{n(n-1)(n-2)}{3!} u_{n-3} v_3 + \cdots + u v_n,$$

where  $u_n = d^n u / dx^n$  etc.

## 2.6 Standard Derivatives

$$\frac{d}{dx}(x^n) = nx^{n-1}$$

$$\frac{d}{dx}(\exp[ax]) = a \exp[ax]$$

$$\frac{d}{dx}(a^x) = a^x \ln a$$

$$\frac{d}{dx}(\ln x) = x^{-1}$$

$$\frac{d}{dx}(\ln(ax + b)) = \frac{a}{(ax + b)}$$

$$\frac{d}{dx}(\log_a x) = x^{-1} \log_a e$$

$$\frac{d}{dx}(\sin(ax + b)) = a \cos(ax + b)$$

$$\frac{d}{dx}(\cos(ax + b)) = -a \sin(ax + b)$$

$$\frac{d}{dx}(\tan(ax + b)) = a \sec^2(ax + b)$$

$$\frac{d}{dx}(\sinh(ax + b)) = a \cosh(ax + b)$$

$$\frac{d}{dx}(\cosh(ax + b)) = a \sinh(ax + b)$$

$$\frac{d}{dx}(\tanh(ax + b)) = a \operatorname{sech}^2(ax + b)$$

$$\frac{d}{dx}(\arcsin(ax + b)) = a [1 - (ax + b)^2]^{-1/2}$$

$$\frac{d}{dx}(\arccos(ax + b)) = -a [1 - (ax + b)^2]^{-1/2}$$

$$\frac{d}{dx}(\arctan(ax + b)) = a [1 + (ax + b)^2]^{-1}$$

$$\frac{d}{dx}(\exp[ax^n]) = anx^{(n-1)} \exp[ax^n]$$

$$\frac{d}{dx}(\sin^2 x) = 2 \sin x \cos x$$

$$\frac{d}{dx}(\cos^2 x) = -2 \sin x \cos x$$



## 2.7 Integration

### Definitions

The area ( $A$ ) under a curve is given by

$$A = \lim_{dx_i \rightarrow 0} \sum f(x_i) dx_i = \int f(x) dx$$

The Indefinite Integral is

$$\int f(x) dx = F(x) + C$$

where  $F(x)$  is a function such that  $F'(x) = f(x)$  and  $C$  is the constant of integration.

The Definite Integral is

$$\int_a^b f(x) dx = F(b) - F(a) = \left[ F(x) \right]_a^b$$

where  $a$  is the lower limit of integration and  $b$  the upper limit of integration.

### Rules of integration

SUM RULE  $\int (f(x) + g(x)) dx = \int f(x) dx + \int g(x) dx$

FACTOR RULE  $\int k f(x) dx = k \int f(x) dx$  where  $k$  is any constant

SUBSTITUTION  $\int f(x) dx = \int f(x) \frac{dx}{du} du$  where  $u = g(x)$  is any function of  $x$

N.B. for definite integrals you must also substitute the values of  $u$  into the limits of the integral.

### Integration by parts

An integral of the form  $\int u(x)q(x) dx$  can sometimes be solved if  $q(x)$  can be integrated and  $u(x)$  differentiated. So if we let  $q(x) = \frac{dv}{dx}$ , so  $v = \int q(x) dx$ , then the *Integration by Parts* formula is

$$\int u \frac{dv}{dx} dx = uv - \int v \frac{du}{dx} dx$$

Note that if you pick  $u$  and  $\frac{dv}{dx}$  the wrong way round you will end up with an integral that is even more complex than the initial one. The aim is to pick  $u$  and  $\frac{dv}{dx}$  such that  $\frac{du}{dx}$  is simplified.

## 2.8 Standard Indefinite Integrals

In the following table  $C$  is the constant of integration.

$$\int x^n dx = \frac{x^{n+1}}{n+1} + C \quad (n \neq -1)$$

$$\int x^{-1} dx = \ln|x| + C$$

$$\int \ln|x| dx = x \ln x - x + C$$

$$\int \sin x dx = -\cos x + C$$

$$\int \cos x dx = \sin x + C$$

$$\int \tan x dx = -\ln|\cos x| + C$$

$$\int \cot x dx = \ln|\sin x| + C$$

$$\int \sec^2 x dx = \tan x + C$$

$$\int \csc^2 x dx = -\cot x + C$$

$$\int \cos^2 x dx = \frac{1}{2}x + \frac{1}{2}\sin x \cos x + C$$

$$\int \sin^2 x dx = \frac{1}{2}x - \frac{1}{2}\sin x \cos x + C$$

$$\int \sin^n x dx = -\frac{\sin^{n-1} x \cos x}{n} + \frac{(n-1)}{n} \int \sin^{n-2} x dx + C$$

$$\int \cos^n x dx = \frac{\cos^{n-1} x \sin x}{n} + \frac{(n-1)}{n} \int \cos^{n-2} x dx + C$$

$$\int \sin x \cos x dx = \frac{1}{2}\sin^2 x + C$$

$$\int \cos mx \cos nx dx = \frac{\sin(m-n)x}{2(m-n)} + \frac{\sin(m+n)x}{2(m+n)} + C \quad (m^2 \neq n^2)$$

$$\int \sin mx \sin nx dx = \frac{\sin(m-n)x}{2(m-n)} - \frac{\sin(m+n)x}{2(m+n)} + C \quad (m^2 \neq n^2)$$

$$\int \sin mx \cos nx dx = -\frac{\cos(m-n)x}{2(m-n)} - \frac{\cos(m+n)x}{2(m+n)} + C \quad (m^2 \neq n^2)$$

$$\int x^2 \cos x dx = (x^2 - 2)\sin x + 2x \cos x + C$$

$$\int x^2 \sin x dx = (2 - x^2)\cos x + 2x \sin x + C$$

$$\int x \cos nx dx = \frac{x \sin nx}{n} + \frac{\cos nx}{n^2} + C$$

$$\int x \sin nx dx = -\frac{x \cos nx}{n} + \frac{\sin nx}{n^2} + C$$

$$\int e^{ax} dx = \frac{e^{ax}}{a} + C$$

$$\int x e^{ax} dx = e^{ax}(x - 1/a)/a + C$$

$$\int x e^{-inx} dx = \frac{1}{n} \left( \frac{1}{n} + ix \right) e^{-inx} + C$$

$$\int e^{ax} \sin kx dx = \frac{e^{ax}(a \sin kx - k \cos kx)}{(a^2 + k^2)} + C$$

$$\int e^{ax} \cos kx dx = \frac{e^{ax}(a \cos kx + k \sin kx)}{(a^2 + k^2)} + C$$

$$\int \sinh x dx = \cosh x + C$$

$$\int \cosh x dx = \sinh x + C$$

$$\int \tanh x dx = \ln \cosh x + C$$

$$\int \operatorname{sech}^2 x dx = \tanh x + C$$

$$\int \operatorname{csch}^2 x dx = \operatorname{coth} x + C$$

$$\int \frac{1}{a^2 + x^2} dx = \frac{1}{a} \arctan \left( \frac{x}{a} \right) + C$$

$$\int \frac{1}{a^2 - x^2} dx = \frac{1}{a} \tanh^{-1} \left( \frac{x}{a} \right) \\ = \frac{1}{2a} \ln \left( \frac{a+x}{a-x} \right) + C$$

$$\int \frac{1}{(a^2 - x^2)^{1/2}} dx = \arcsin \left( \frac{x}{a} \right) + C \\ = -\arccos \left( \frac{x}{a} \right) + C$$

$$\int \frac{1}{(x^2 - a^2)^{1/2}} dx = \cosh^{-1} \left( \frac{x}{a} \right) + C$$

$$\int \frac{x^2}{(a^2 + x^2)} dx = x - a \arctan \left( \frac{x}{a} \right) + C$$

$$\int \frac{1}{(a^2 + x^2)^{1/2}} dx = \ln[x + (x^2 + a^2)^{1/2}] + C \\ = \sinh^{-1} \left( \frac{x}{a} \right) + C$$

$$\int \frac{1}{(a^2 + x^2)^{3/2}} dx = \sin \left[ \arctan \left( \frac{x}{a} \right) \right] / a^2 + C \\ = \frac{1}{a^2} \frac{x}{(a^2 + x^2)^{1/2}} + C$$

$$\int \frac{x^{1/2}}{(a-x)^{1/2}} dx = a \arcsin(\sqrt{(x/a)}) - a\sqrt{x/a - (x/a)^2} + C$$

$$\int \frac{x}{(a^2 + x^2)^{1/2}} dx = (a^2 + x^2)^{1/2} + C$$

$$\int \frac{1}{(a + bx^2)^2} dx = \frac{x}{2a(a + bx^2)} + \frac{1}{2a\sqrt{ab}} \arctan[x\sqrt{(b/a)}] + C$$

## 2.9 Definite Integrals

$$\int_0^{\infty} x^{1/2} e^{-x} dx = \frac{\sqrt{\pi}}{2} \qquad \int_0^{\infty} \frac{x^{1/2}}{(e^x - 1)} dx = \frac{2.61\sqrt{\pi}}{2}$$

$$\int_0^{\infty} x^n e^{-x} dx = \int_0^1 \left(\ln \frac{1}{x}\right)^n = \Gamma(n+1) \quad \text{the Gamma function}$$

Note: for  $n$  an integer greater than 0,  $\Gamma(n+1) = n!$ ,  $\Gamma(1) = 0! = 1$

$$\frac{2}{\sqrt{\pi}} \int_0^u e^{-x^2} dx = \operatorname{erf}(u) \quad \text{the Error function}$$

Note that  $\operatorname{erf}(\infty) = 1$ , so that  $\frac{2}{\sqrt{\pi}} \int_0^{\infty} e^{-ax^2} dx = \frac{1}{\sqrt{a}}$ .

$$\int_{-\infty}^{\infty} e^{-ax^2} dx = \sqrt{\frac{\pi}{a}}$$

$$\int_0^{\infty} x^{2n} e^{-ax^2} dx = \frac{1 \times 3 \times 5 \times \dots \times (2n-1)}{2^{n+1} a^n} \sqrt{\frac{\pi}{a}} \equiv S \quad (n = 1, 2, 3 \dots)$$

$$\int_{-\infty}^{\infty} x^{2n} e^{-ax^2} dx = 2S$$

$$\int_0^{\infty} x^{2n+1} e^{-ax^2} dx = \frac{n!}{2a^{n+1}} \quad (a > 0; n = 0, 1, 2 \dots)$$

$$\int_{-\infty}^{+\infty} x^{2n+1} e^{-ax^2} dx = 0$$

$$\int_0^{\infty} x^2 \ln(1 - e^{-x}) dx = \frac{-\pi^4}{45}$$

$$\int_0^{\infty} e^{-ax} \cos(kx) dx = \frac{a}{a^2 + k^2}$$

$$\int_0^{\infty} \frac{1}{1+x^{2n}} dx = \frac{\pi/2n}{\sin(\pi/2n)}$$

## 2.10 Curvilinear Coordinate Systems

### Definitions

#### Spherical Coordinates

$$\begin{aligned}x &= r \sin \theta \cos \phi \\y &= r \sin \theta \sin \phi \\z &= r \cos \theta\end{aligned}$$

#### Cylindrical Coordinates

$$\begin{aligned}x &= r \cos \phi \\y &= r \sin \phi \\z &= z\end{aligned}$$

### Elements of area and volume

#### Elements of Area

$$\begin{array}{ll}\text{Cartesian } (x, y) & dS = dx dy \\ \text{Plane polar } (r, \theta) & dS = r dr d\theta\end{array}$$

#### Elements of Volume

$$\begin{array}{ll}\text{Cartesian } (x, y, z) & dV = dx dy dz \\ \text{Spherical polar } (r, \theta, \phi) & dV = r^2 \sin \theta dr d\theta d\phi \\ \text{Cylindrical polar } (r, \phi, z) & dV = r dr d\phi dz\end{array}$$

#### MISCELLANEOUS

Area of elementary circular annulus, width  $dr$ , centred on the origin:  $dS = 2\pi r dr$

Volume of elementary cylindrical annulus of height  $dz$  and thickness  $dr$ :  $dV = 2\pi r dr dz$

Volume of elementary spherical shell of thickness  $dr$ , centred on the origin:  $dV = 4\pi r^2 dr$

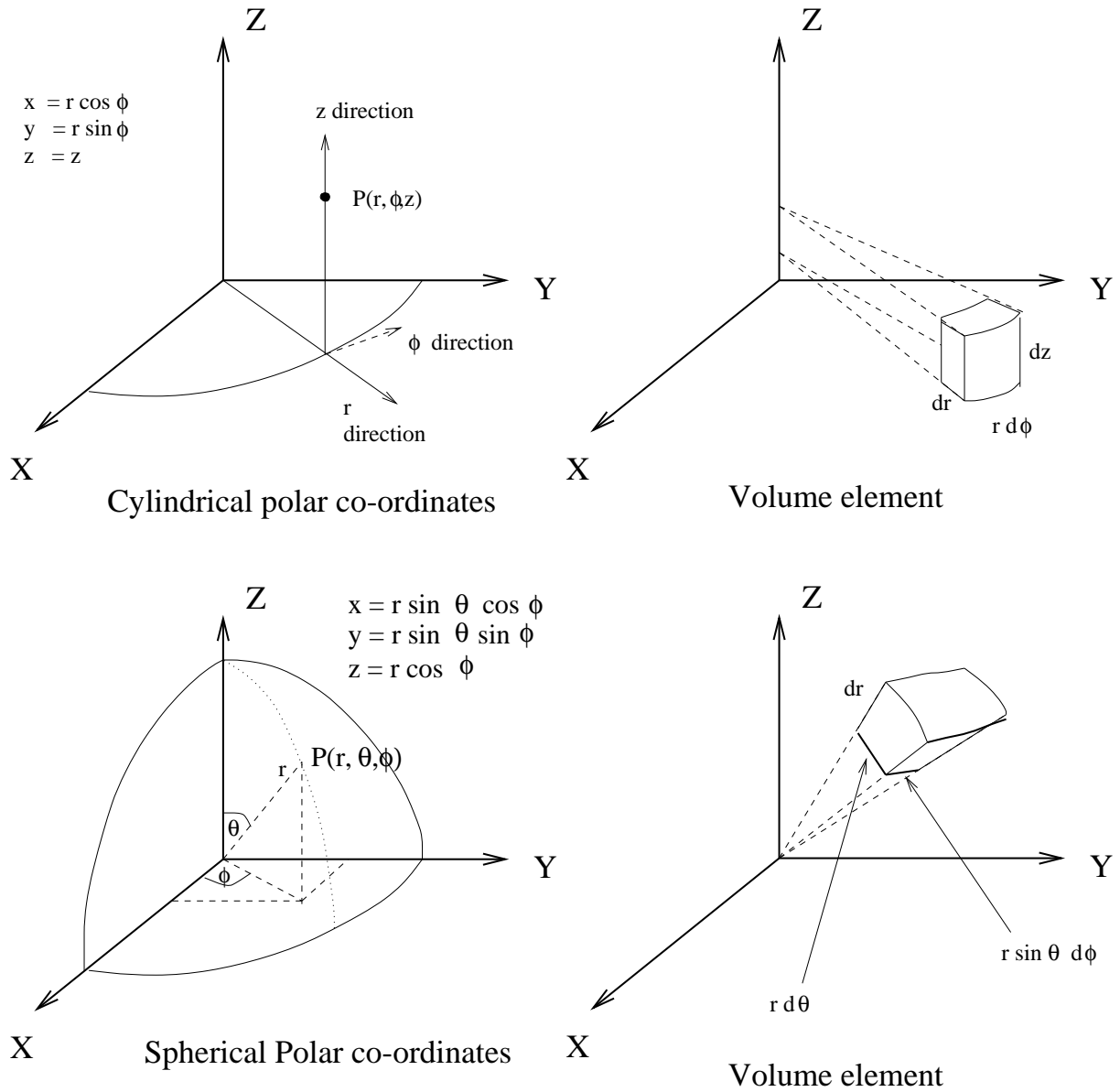

Figure 2.1: Coordinate Systems and Elements of volume.

## Solid angle

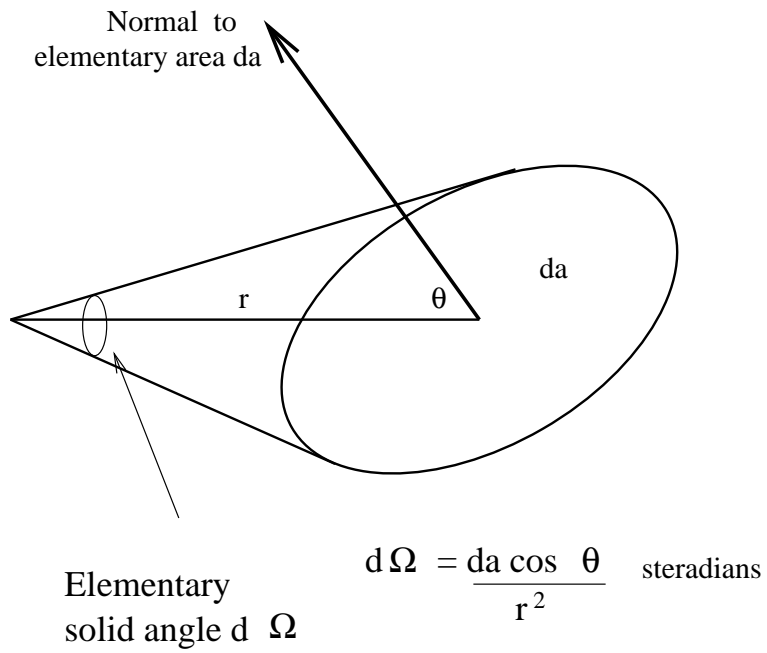

Figure 2.2: Solid angle.

1. The solid angle subtended by any closed surface at any point inside the surface is  $4\pi$ ;
2. The solid angle subtended by any closed surface at a point outside the surface is zero.

## 2.11 Vectors and Vector Algebra

Vectors are quantities with *both* magnitude and direction; they are combined by the triangle rule (see Fig. 2.3).

$$\mathbf{A} + \mathbf{B} = \mathbf{B} + \mathbf{A} = \mathbf{C}$$

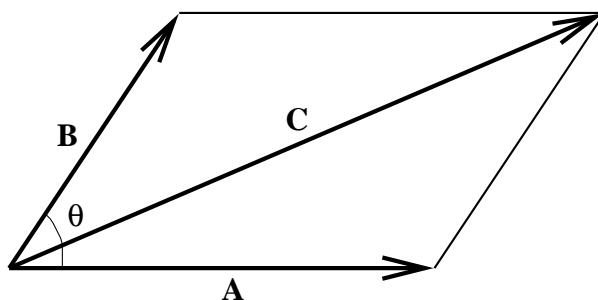

Figure 2.3: Vector addition.

Vectors may be denoted by bold type  $\mathbf{A}$ , by putting a little arrow over the symbol  $\vec{A}$ , or by underlining the symbol  $\underline{A}$ . Unit vectors are usually denoted by a circumflex accent (e.g.  $\hat{\mathbf{i}}$ ).

### Magnitude etc.

$$|\mathbf{A}| = \sqrt{(\mathbf{A} \cdot \mathbf{A})} = \sqrt{(A_x^2 + A_y^2 + A_z^2)}$$

The angle  $\theta$  between two vectors  $\mathbf{A}$  and  $\mathbf{B}$  is given by

$$\cos \theta = \frac{\mathbf{A} \cdot \mathbf{B}}{|\mathbf{A}||\mathbf{B}|} = \frac{A_x B_x + A_y B_y + A_z B_z}{\sqrt{(A_x^2 + A_y^2 + A_z^2)(B_x^2 + B_y^2 + B_z^2)}}$$

### Unit vectors

Unit vector in the direction of  $\mathbf{A} = \mathbf{A}/|\mathbf{A}|$

Cartesian co-ordinates:  $\hat{\mathbf{i}}, \hat{\mathbf{j}}, \hat{\mathbf{k}}$  are unit vectors in the directions of the  $x, y, z$  cartesian axes respectively.

If  $A_x, A_y, A_z$  are the cartesian components of  $\mathbf{A}$  then

$$\mathbf{A} = \hat{\mathbf{i}}A_x + \hat{\mathbf{j}}A_y + \hat{\mathbf{k}}A_z$$

### Addition and subtraction

$$\mathbf{A} + \mathbf{B} = \mathbf{B} + \mathbf{A} \quad (\text{Commutative law})$$

$$(\mathbf{A} + \mathbf{B}) + \mathbf{C} = \mathbf{A} + (\mathbf{B} + \mathbf{C}) \quad (\text{Associative law})$$



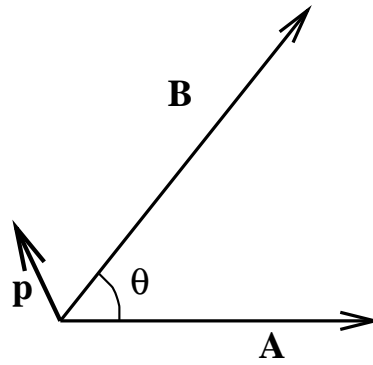

Figure 2.4: Vector (or Cross) Product; the vector  $\mathbf{p}$  is directed out of the page.

## Products

### SCALAR PRODUCT

$$\mathbf{A} \cdot \mathbf{B} \equiv |\mathbf{A}||\mathbf{B}| \cos \theta = \mathbf{B} \cdot \mathbf{A} \quad (\text{a scalar})$$

$$\hat{\mathbf{i}} \cdot \hat{\mathbf{i}} = \hat{\mathbf{j}} \cdot \hat{\mathbf{j}} = \hat{\mathbf{k}} \cdot \hat{\mathbf{k}} = 1$$

$$\hat{\mathbf{i}} \cdot \hat{\mathbf{j}} = \hat{\mathbf{j}} \cdot \hat{\mathbf{k}} = \hat{\mathbf{k}} \cdot \hat{\mathbf{i}} = 0$$

$$\mathbf{A} \cdot \mathbf{B} = A_x B_x + A_y B_y + A_z B_z$$

$$\mathbf{A} \cdot (\mathbf{B} + \mathbf{C}) = \mathbf{A} \cdot \mathbf{B} + \mathbf{A} \cdot \mathbf{C}$$

### VECTOR (OR CROSS) PRODUCT

See Fig. 2.4

$$\mathbf{A} \times \mathbf{B} = -\mathbf{B} \times \mathbf{A} = (|\mathbf{A}||\mathbf{B}| \sin \theta) \hat{\mathbf{p}} \quad (\text{a vector})$$

where  $\hat{\mathbf{p}}$  is a *unit* vector perpendicular to both  $\mathbf{A}$  and  $\mathbf{B}$ . Note that the vector product is non-commutative.

$$\hat{\mathbf{i}} \times \hat{\mathbf{j}} = \hat{\mathbf{k}} \quad \hat{\mathbf{j}} \times \hat{\mathbf{k}} = \hat{\mathbf{i}} \quad \hat{\mathbf{k}} \times \hat{\mathbf{i}} = \hat{\mathbf{j}}$$

$$\hat{\mathbf{i}} \times \hat{\mathbf{i}} = \hat{\mathbf{j}} \times \hat{\mathbf{j}} = \hat{\mathbf{k}} \times \hat{\mathbf{k}} = 0$$

Also, in cartesian co-ordinates,

$$\begin{aligned} \mathbf{A} \times \mathbf{B} &= (A_y B_z - A_z B_y) \hat{\mathbf{i}} + (A_z B_x - A_x B_z) \hat{\mathbf{j}} + (A_x B_y - A_y B_x) \hat{\mathbf{k}} \\ &= \begin{vmatrix} \hat{\mathbf{i}} & \hat{\mathbf{j}} & \hat{\mathbf{k}} \\ A_x & A_y & A_z \\ B_x & B_y & B_z \end{vmatrix} \end{aligned}$$

## Scalar triple product

$$(\mathbf{A} \times \mathbf{B}) \cdot \mathbf{C} = (\mathbf{B} \times \mathbf{C}) \cdot \mathbf{A} = (\mathbf{C} \times \mathbf{A}) \cdot \mathbf{B} \quad (\text{a scalar})$$

(Note the cyclic order:  $\mathbf{A} \rightarrow \mathbf{B} \rightarrow \mathbf{C}$ )

$$\begin{aligned} &= \begin{vmatrix} A_x & A_y & A_z \\ B_x & B_y & B_z \\ C_x & C_y & C_z \end{vmatrix} \\ &= A_x(B_y C_z - B_z C_y) + A_y(B_z C_x - B_x C_z) + A_z(B_x C_y - B_y C_x) \end{aligned}$$

## Vector triple product

$$\mathbf{A} \times (\mathbf{B} \times \mathbf{C}) = (\mathbf{A} \cdot \mathbf{C})\mathbf{B} - (\mathbf{A} \cdot \mathbf{B})\mathbf{C} \quad (\text{a vector})$$

$$\mathbf{A} \times (\mathbf{B} \times \mathbf{C}) + \mathbf{B} \times (\mathbf{C} \times \mathbf{A}) + \mathbf{C} \times (\mathbf{A} \times \mathbf{B}) = \mathbf{0} \quad (\text{Note the cyclic order: } \mathbf{A} \rightarrow \mathbf{B} \rightarrow \mathbf{C})$$

## 2.12 Complex Numbers

$z = a + ib$  is a complex number where  $a, b$  are *real* and  $i = \sqrt{-1}$  (N.B. sometimes  $j$  is used instead of  $i$ ).

$a$  is the *real* part of  $z$  and  $b$  is the *imaginary* part. Sometimes the real part of a complex quantity  $z$  is denoted by  $\Re(z)$ , the imaginary part by  $\Im(z)$ .

If  $a_1 + ib_1 = a_2 + ib_2$  then  $a_1 = a_2$  and  $b_1 = b_2$ .

### Modulus and argument

The modulus of  $z \equiv |z| = \sqrt{a^2 + b^2}$ .

The argument of  $z = \theta = \arctan(b/a)$

### Complex conjugate

To form the complex conjugate of any complex number simply replace  $i$  by  $-i$  wherever it occurs in the number. Thus if  $z = a + ib$  then the complex conjugate is  $z^* = a - ib$ .

If  $z = Ae^{-ix}$  then  $z^* = A^*e^{+ix}$ .

Note:  $|z| = \sqrt{zz^*} = \sqrt{(a + ib)(a - ib)} = \sqrt{a^2 + b^2}$

### Rationalization

If  $z = A/B$ , where  $A$  and  $B$  are both complex numbers, then the quotient can be 'rationalized' as follows:

$$z = \frac{A}{B} = \frac{AB^*}{BB^*} = \frac{AB^*}{|B|^2}$$

and the *denominator* is now real.

### Polar form

See Fig. 2.5. If  $z = a + ib$  then  $|z| = \sqrt{a^2 + b^2}$  and  $\theta = \arctan(b/a)$ . Note when evaluating  $\arctan(b/a)$ ,  $\theta$  must be put in the correct quadrant (see Fig 2.6).

$$e^{i\theta} = \cos \theta + i \sin \theta \quad (\text{Euler's identity})$$

$$\sin \theta = \frac{e^{i\theta} - e^{-i\theta}}{2i} \qquad \cos \theta = \frac{e^{i\theta} + e^{-i\theta}}{2}$$

$$\begin{aligned} z &= a + ib \\ &= |z| \cos \theta + i|z| \sin \theta \\ &= |z| \exp[i\theta] \end{aligned}$$

$$\begin{aligned} \text{If } z_1 &= |z_1| \exp[i\theta_1] \text{ and } z_2 = |z_2| \exp[i\theta_2] \\ \text{then } z_1 z_2 &= |z_1| |z_2| \exp i[\theta_1 + \theta_2] \\ \text{and } \frac{z_1}{z_2} &= \frac{|z_1|}{|z_2|} \exp i[\theta_1 - \theta_2] \end{aligned}$$

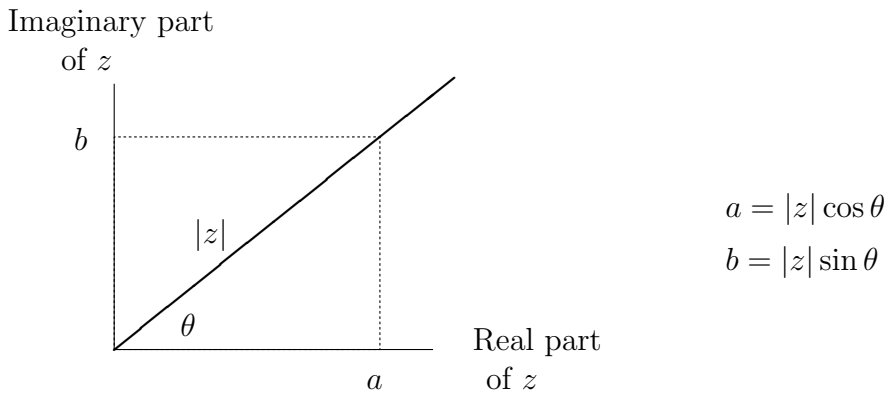

Figure 2.5: Argand diagram.

If  $z^n = w$  where  $w = |w| \exp[i\theta]$   
then  $z = |w|^{1/n} \exp[i(\theta + 2k\pi)/n]$  where  $k = 0, 1, 2 \dots (n - 1)$

$$|z^n| = |z|^n$$

$$|z|^m |z|^n = |z|^{m+n}$$

$$\left| \frac{z_1}{z_2} \right| = \frac{|z_1|}{|z_2|}$$

### DeMoivre's theorem

$$e^{in\theta} = (\cos \theta + i \sin \theta)^n = \cos n\theta + i \sin n\theta \quad \text{where } n \text{ is an integer}$$

### Trigonometric and hyperbolic functions

$\sinh(i\theta) = i \sin \theta$	$\sin(i\theta) = i \sinh \theta$
$\cosh(i\theta) = \cos \theta$	$\cos(i\theta) = \cosh \theta$
$\tanh(i\theta) = i \tan \theta$	$\tan(i\theta) = i \tanh \theta$

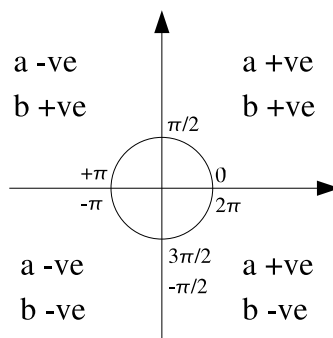

Figure 2.6: Selecting the correct quadrant for  $\theta = \arctan(b/a)$

## 2.13 Series

### Arithmetic progression (A.P.)

$$S = a + (a + d) + (a + 2d) + (a + 3d) + \dots + (a + [n - 1]d)$$

Sum over  $n$  terms is

$$S_n = \frac{n}{2}[2a + (n - 1)d]$$

### Geometric progression (G.P.)

$$S = a + ar + ar^2 + ar^3 + \dots + ar^{n-1}$$

Sum over  $n$  terms is

$$S_n = \frac{a(1 - r^n)}{(1 - r)}$$

If  $|r| < 1$  the sum to infinity is

$$S_\infty = \frac{a}{(1 - r)}$$

### Binomial theorem

$$(a + b)^n = a^n + na^{n-1}b + \frac{n(n-1)}{2!}a^{n-2}b^2 + \frac{n(n-1)(n-2)}{3!}a^{n-3}b^3 + \dots$$

If  $n$  is a *positive integer* the series contains  $(n + 1)$  terms. If  $n$  is a *negative integer* or a positive or negative *fraction* the series is infinite. The series converges if  $|b/a| < 1$ .

Special cases:

$$\begin{aligned} (1 \pm x)^n &= 1 \pm nx + \frac{n(n-1)}{2!}x^2 \pm \frac{n(n-1)(n-2)}{3!}x^3 + \dots \text{ Valid for all } n. \\ (1 \pm x)^{-1} &= 1 \mp x + x^2 \mp x^3 + x^4 \mp \dots \\ (1 \pm x)^{-2} &= 1 \mp 2x + 3x^2 \mp 4x^3 + 5x^4 \mp \dots \\ (1 \pm x)^{\frac{1}{2}} &= 1 \pm \frac{x}{2} - \frac{x^2}{8} \pm \frac{x^3}{16} - \frac{5x^4}{128} \pm \dots \\ (1 \pm x)^{-\frac{1}{2}} &= 1 \mp \frac{x}{2} + \frac{3x^2}{8} \mp \frac{5x^3}{16} + \frac{35x^4}{128} \mp \dots \end{aligned}$$

### Maclaurin's theorem

$$f(x) = f(0) + x \left. \frac{df}{dx} \right|_{x=0} + \frac{x^2}{2!} \left. \frac{d^2f}{dx^2} \right|_{x=0} + \frac{x^3}{3!} \left. \frac{d^3f}{dx^3} \right|_{x=0} + \dots + \frac{x^n}{n!} \left. \frac{d^n f}{dx^n} \right|_{x=0} + \dots$$

where, for example  $d^2f/dx^2|_{x=0}$  means the result of forming the second derivative of  $f(x)$  with respect to  $x$  and *then* setting  $x = 0$ .

## Taylor's theorem

$$f(x) = f(a) + (x-a) \left. \frac{df}{dx} \right|_{x=a} + \frac{(x-a)^2}{2!} \left. \frac{d^2f}{dx^2} \right|_{x=a} + \frac{(x-a)^3}{3!} \left. \frac{d^3f}{dx^3} \right|_{x=a} + \dots$$

$$\dots + \frac{(x-a)^n}{n!} \left. \frac{d^n f}{dx^n} \right|_{x=a} + \dots$$

where, for example  $d^2f/dx^2|_{x=a}$  again means the result of forming the second derivative of  $f(x)$  with respect to  $x$  and *then* setting  $x = a$ .

## Series expansions of trigonometric functions

$$\sin \theta = \theta - \frac{\theta^3}{3!} + \frac{\theta^5}{5!} - \frac{\theta^7}{7!} + \dots$$

$$\cos \theta = 1 - \frac{\theta^2}{2!} + \frac{\theta^4}{4!} - \frac{\theta^6}{6!} + \dots$$

For  $\theta$  in *radians* and small (i.e.  $\theta \ll 1$ ):

$$\sin \theta \simeq \theta \quad \text{Error} \lesssim 4\% \text{ for } \theta \lesssim 30^\circ \simeq 0.52 \text{ radians}$$

$$\tan \theta \simeq \theta \quad \text{Error} \lesssim 4\% \text{ for } \theta \lesssim 30^\circ \simeq 0.52 \text{ radians}$$

$$\cos \theta \simeq 1 \quad \text{Error} \lesssim 4\% \text{ for } \theta \lesssim 16^\circ \simeq 0.28 \text{ radians}$$

## Series expansions of exponential functions

$$e^{\pm x} = 1 \pm x + \frac{x^2}{2!} \pm \frac{x^3}{3!} + \frac{x^4}{4!} + \dots \quad \text{Convergent for all values of } x$$

$$\ln(1+x) = x - \frac{x^2}{2} + \frac{x^3}{3} - \frac{x^4}{4} + \dots \quad \text{Convergent for } -1 < x \leq 1$$

For  $x$  small (i.e.  $x \ll 1$ ):

$$e^{\pm x} \equiv \exp[\pm x] \simeq 1 \pm x \dots$$

$$\ln(1 \pm x) \simeq \pm x \dots$$

## Series expansions of hyperbolic functions

$$\sinh x \equiv \frac{1}{2}(e^x - e^{-x}) = x + \frac{x^3}{3!} + \frac{x^5}{5!} + \dots$$

$$\cosh x \equiv \frac{1}{2}(e^x + e^{-x}) = 1 + \frac{x^2}{2!} + \frac{x^4}{4!} + \dots$$

## L'Hôpital's rule

If two functions  $f(x)$  and  $g(x)$  are both zero or infinite at  $x = a$  the ratio  $f(x)/g(x)$  is undefined. However the limit of  $f(x)/g(x)$  as  $x$  approaches  $a$  may exist. This may be found from

$$\lim_{x \rightarrow a} \frac{f(x)}{g(x)} = \frac{f'(a)}{g'(a)}$$

where  $f'(a)$  means the result of differentiating  $f(x)$  with respect to  $x$  and *then* putting  $x = a$ .

## Convergence Tests

### D'Alembert's ratio test

In a series,  $\sum_{n=1}^{\infty} a_n$ , let the ratio  $R = \lim_{n \rightarrow \infty} \left( \frac{a_{n+1}}{a_n} \right)$ .

- If  $R < 1$  the series is *convergent*
- If  $R > 1$  the series is *divergent*
- If  $R = 1$  the test fails.

### The Integral Test

A sum to infinity of  $a_n$  converges if  $\int_1^{\infty} a_n \, dn$  is finite. This can only be applied to series where  $a_n$  is positive and decreasing as  $n$  gets larger.

## 2.14 Ordinary Differential Equations

### General points

1. In general, finding a function which is 'a solution of' (i.e. satisfies) any particular differential equation is a trial and error process. It involves inductive not deductive reasoning, comparable with integration as opposed to differentiation.
2. If the highest differential coefficient in the equation is the  $n^{\text{th}}$  then the general solution must contain  $n$  arbitrary constants.
3. The known physical conditions—the *boundary conditions*—may enable one particular solution or a set of solutions to be selected from the infinite family of possible mathematical solutions; that is boundary conditions may allow specific values to be assigned to the arbitrary constants in the general solution.
4. Virtually all the ordinary differential equations met in basic physics are *linear*, that is the differential coefficients occur to the *first power* only.

### Definitions

#### ORDER OF A DIFFERENTIAL EQUATION

The *order* of a differential equation is the order of the highest differential coefficient it contains.

#### DEGREE OF A DIFFERENTIAL EQUATION

The *degree* of a differential equation is the power to which the *highest order differential coefficient* is raised.

#### DEPENDENT AND INDEPENDENT VARIABLES

Ordinary differential equations involve only two variables, one of which is referred to as the *dependent* variable and the other as the *independent* variable. It is usually clear from the nature of the physical problem which is the independent and which is the dependent variable.



## First Order Differential Equations

### Direct Integration

The equation  $\frac{dy}{dx} = f(x)$  has the solution  $y = \int f(x)dx$ . Thus it can be solved (in principle) by direct integration.

### Separable Variables

First order differential equations of the form  $\frac{dy}{dx} = f(x)g(y)$ , where  $f(x)$  is a function of  $x$  only and  $g(y)$  is a function of  $y$  only. Dividing both sides by  $g(y)$  and integrating gives  $\int \frac{dy}{g(y)} = \int f(x) dx + C$ , which can be used to obtain the solution of  $y(x)$ .

### The linear equation

A general first order linear equation of the form  $\frac{dy}{dx} + P(x)y = Q(x)$

This can be solved by multiplying through by an 'integrating factor'  $e^I$ , where  $I = \int P(x)dx$ , so that the original equation can be rewritten as

$$\frac{d}{dx} (ye^I) = e^I Q(x)$$

Since  $Q$  and  $I$  are only functions of  $x$  we can integrate both sides to obtain

$$ye^I = \int Q(x)e^I dx$$

## Second Order Differential Equations

### Direct Integration

Equations of the form  $\frac{d^2y}{dx^2} = f(x)$ , can be solved by integrating twice:

$$y = \int \left[ \int f(x)dx + C \right] dx = \int \left[ \int f(x)dx \right] dx + Cx + D$$

Note that there are two arbitrary constants,  $C$  and  $D$ .

## Homogeneous Second Order Differential Equations

$$a \frac{d^2 y}{dx^2} + b \frac{dy}{dx} + cy = 0$$

where  $a$ ,  $b$  and  $c$  are constants. Letting  $y = Ae^{\alpha x}$ , gives the auxiliary equation

$$a\alpha^2 + b\alpha + c = 0$$

This is solved for  $\alpha$  using the quadratic equation, which gives two values for  $\alpha$ ,  $\alpha_1$  and  $\alpha_2$ . The general solution is the combination of the two,  $y = Ae^{\alpha_1 x} + Be^{\alpha_2 x}$ .

**The auxiliary equation has real roots** When  $b^2 > 4ac$ , both  $\alpha_1$  and  $\alpha_2$  are real. The general solution is  $y = Ae^{\alpha_1 x} + Be^{\alpha_2 x}$ .

**The auxiliary equation has complex roots** When  $b^2 < 4ac$ , both  $\alpha_1$  and  $\alpha_2$  are complex. Using Euler's Equation, substituting  $C = A+B$  and  $D = i(A-B)$ , the general solution can be written as

$$y = e^{\alpha x} (C \cos(\beta x) + D \sin(\beta x))$$

where  $\alpha = -b/(2a)$  and  $\beta = \sqrt{(4ac - b^2)}/(2a)$ .

**The auxiliary equation has equal roots** When  $b^2 = 4ac$ , there is only one  $\alpha$ . The general solution is given by  $y = (A + Bx)e^{\alpha x}$

## Non-homogeneous Second Order Differential Equations

Non-homogeneous second order differential equations are of the form

$$a \frac{d^2 y}{dx^2} + b \frac{dy}{dx} + cy = f(x)$$

To solve, first solve the homogeneous equation (i.e. for right-hand side = 0),

$$a \frac{d^2 y}{dx^2} + b \frac{dy}{dx} + cy = 0$$

using the method given above to get the solution

$$y = Ae^{\alpha_1 x} + Be^{\alpha_2 x}$$

which is known as the *complementary function (CF)*. Then we find a *particular solution (PS)* for the whole equation. The *general solution* is CF + PS.

The particular solution is taken to be the same form as the function  $f(x)$ .

$f(x) = k$	assume	$y = C$
$f(x) = kx$	assume	$y = Cx + D$
$f(x) = kx^2$	assume	$y = Cx^2 + Dx + E$
$f(x) = k \sin x$ or $k \cos x$	assume	$y = C \cos x + D \sin x$
$f(x) = e^{kx}$	assume	$y = Ce^{kx}$

## 2.15 Partial Differentiation

### Definition

If  $f = f(x, y)$  with  $x$  and  $y$  independent, then

$$\begin{aligned} \left(\frac{\partial f}{\partial x}\right)_y &\equiv \lim_{\delta x \rightarrow 0} \frac{f(x + \delta x, y) - f(x, y)}{\delta x} \\ &= \text{derivative with respect to } x \text{ with } y \text{ kept constant} \end{aligned}$$

$$\begin{aligned} \left(\frac{\partial f}{\partial y}\right)_x &\equiv \lim_{\delta y \rightarrow 0} \frac{f(x, y + \delta y) - f(x, y)}{\delta y} \\ &= \text{derivative with respect to } y \text{ with } x \text{ kept constant} \end{aligned}$$

The rules of partial differentiation are the same as differentiation, always bearing in mind which term is varying and which are constant.

### Convenient notation

$$f_x = \frac{\partial f}{\partial x}, f_{xx} = \frac{\partial^2 f}{\partial x^2}, f_{xy} = \frac{\partial^2 f}{\partial x \partial y}, f_y = \frac{\partial f}{\partial y}, f_{yy} = \frac{\partial^2 f}{\partial y^2}, f_{yx} = \frac{\partial^2 f}{\partial y \partial x}$$

Note that for functions with continuous derivatives  $f_{xy} = \frac{\partial^2 f}{\partial x \partial y} = \frac{\partial^2 f}{\partial y \partial x} = f_{yx}$

### Total Derivatives

Total change in  $f$  due to infinitesimal changes in both  $x$  and  $y$ :

$$df = \left(\frac{\partial f}{\partial x}\right)_y dx + \left(\frac{\partial f}{\partial y}\right)_x dy$$

$\frac{df}{dx} = \left(\frac{\partial f}{\partial x}\right)_y + \left(\frac{\partial f}{\partial y}\right)_x \frac{dy}{dx}$  is the *total derivative* of  $f$  with respect to  $x$ .

$\frac{df}{dy} = \left(\frac{\partial f}{\partial y}\right)_x + \left(\frac{\partial f}{\partial x}\right)_y \frac{dx}{dy}$  is the *total derivative* of  $f$  with respect to  $y$ .

For a function where each variable depends upon a third parameter, such as  $f(x, y)$  where  $x$  and  $y$  depend on time ( $t$ ):

$$\frac{df}{dt} = \left(\frac{\partial f}{\partial x}\right)_y \frac{dx}{dt} + \left(\frac{\partial f}{\partial y}\right)_x \frac{dy}{dt}$$

## Maxima and Minima with two or more variables

If  $f$  is a function of two or more variables we can still find the maximum and minimum points of the function. Consider a 3-d surface given by  $f = f(x, y)$ . We can identify the following types of *stationary points* where gradients are zero:

**peak** – a *local maximum*

**pit** – a *local minimum*

**pass** or *saddle point* – minimum in one direction, maximum in the other.

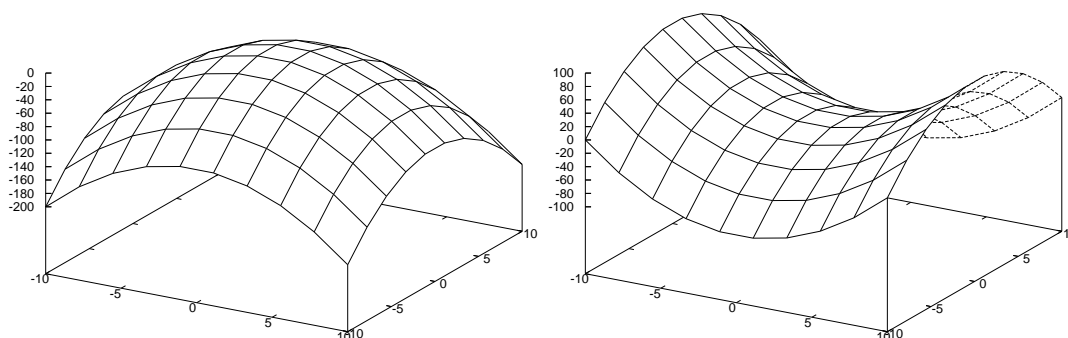

Figure 2.7: Surface plots showing a peak (left) and a saddle Point (right)

At each peak, pit or pass, the function  $f$  is stationary, i.e.

$$\frac{\partial f}{\partial x} = \frac{\partial f}{\partial y} = 0$$

Let  $f(x_0, y_0)$  be a stationary point and define the *second derivative test discriminant* as

$$D = \left( \frac{\partial^2 f}{\partial x^2} \right) \left( \frac{\partial^2 f}{\partial y^2} \right) - \left( \frac{\partial^2 f}{\partial x \partial y} \right)^2 = f_{xx}f_{yy} - f_{xy}^2$$

which is evaluated at  $(x_0, y_0)$  and,

if  $D > 0$  and  $f_{xx} > 0$  we have a pit (minimum)

if  $D > 0$  and  $f_{xx} < 0$  we have a peak (maximum)

if  $D < 0$  we have a pass (saddle point)

if  $D = 0$  we do not know, have to test further comparing  $f(x_0, y_0)$ ,  $f(x_0 \pm dx, y_0)$ ,  $f(x_0, y_0 \pm dy)$ , i.e. compare with values close to  $f(x_0, y_0)$ .

## 2.16 Partial Differential Equations

The following partial differential equations are basic to physics:

One dimension

Three dimensions

--	$\nabla^2\phi = 0$	Laplace's equation
--	$\nabla^2\phi = \text{constant}$	Poisson's equation
$\frac{\partial^2\phi}{\partial x^2} = D \frac{\partial\phi}{\partial t}$	$\nabla^2\phi = D \frac{\partial\phi}{\partial t}$	Diffusion equation
$\frac{\partial^2\phi}{\partial x^2} = \frac{1}{c^2} \frac{\partial^2\phi}{\partial t^2}$	$\nabla^2\phi = \frac{1}{c^2} \frac{\partial^2\phi}{\partial t^2}$	Wave equation

In general a partial differential equation can be satisfied by a wide variety of different functions, i.e. if  $\phi = f(x, t)$  or  $\phi = f(x, y, z)$ ,  $f$  may take many different forms which are *not* equivalent ways of representing the same set of surfaces. For example, *any* continuous, differentiable function of  $(x \pm ct)$  will fit the one-dimensional wave equation.

'Solving' these partial differential equations in a particular physical context therefore involves choosing not just constants but also the functions which fit the boundary conditions. Equations involving three or four independent variables, e.g.  $(x, y, t)$  or  $(x, y, z, t)$  can be solved only when the 'boundaries' are surfaces of some simple co-ordinate system, such as rectangular, polar, cylindrical polar, spherical polar. The partial differential equations can then be separated into a number of *ordinary* differential equations in the separate co-ordinates, and solutions can be expressed as expansions of various classical mathematical functions. This is analogous to the general representation of the solution  $f(x \pm ct)$  of the one-dimensional wave equation by a Fourier series of sine and cosine functions.

## 2.17 Determinants and Matrices

### Determinants

The general set of simultaneous linear equations may be written as:

$$a_{11}x_1 + a_{12}x_2 + a_{13}x_3 + \cdots + a_{1n}x_n = y_1$$

$$a_{21}x_1 + a_{22}x_2 + a_{23}x_3 + \cdots + a_{2n}x_n = y_2$$

$$a_{31}x_1 + a_{32}x_2 + a_{33}x_3 + \cdots + a_{3n}x_n = y_3$$

$$\vdots$$

$$a_{m1}x_1 + a_{m2}x_2 + a_{m3}x_3 + \cdots + a_{mn}x_n = y_m$$

The solutions of these equations are:

$$x_k = \frac{1}{D} \sum_{j=1}^n y_j D_{jk} \quad (\text{Cramer's rule})$$

where

$$D = \begin{vmatrix} a_{11} & a_{12} & a_{13} & \cdots & a_{1n} \\ a_{21} & a_{22} & a_{23} & \cdots & a_{2n} \\ \vdots & & & & \\ a_{m1} & a_{m2} & a_{m3} & \cdots & a_{mn} \end{vmatrix}$$

is the *determinant* of the coefficients of the  $x_i$  and where

$$D_{jk} = (-1)^{j+k} \times [\text{determinant obtained by suppressing the } j^{\text{th}} \text{ row and the } k^{\text{th}} \text{ column of } D]$$

$D_{jk}$  is called the *co-factor* of  $a_{jk}$ . The determinant  $D$  can be expanded, and ultimately evaluated, as follows:

$$D = a_{11}D_{11} + a_{12}D_{12} + \cdots + a_{1n}D_{1n} \quad (\text{'expansion by the first row'})$$

or

$$D = a_{11}D_{11} + a_{21}D_{21} + \cdots + a_{m1}D_{m1} \quad (\text{'expansion by the first column'})$$

The expansion procedure is repeated for  $D_{1n}$  etc. until the remaining determinants have dimensions  $2 \times 2$ . If

$$D = \begin{vmatrix} a & b \\ c & d \end{vmatrix} \quad \text{then } D = (ad - bc)$$

Note: this method is very tedious for  $m, n > 3$  and it may be better to use a 'condensation' procedure (see text books).

EXAMPLE

$$\begin{vmatrix} a_{11} & a_{12} & a_{13} \\ a_{21} & a_{22} & a_{23} \\ a_{31} & a_{32} & a_{33} \end{vmatrix} = a_{11} \begin{vmatrix} a_{22} & a_{23} \\ a_{32} & a_{33} \end{vmatrix} - a_{12} \begin{vmatrix} a_{21} & a_{23} \\ a_{31} & a_{33} \end{vmatrix} + a_{13} \begin{vmatrix} a_{21} & a_{22} \\ a_{31} & a_{32} \end{vmatrix}$$

$$= a_{11}(a_{22}a_{33} - a_{32}a_{23}) - a_{12}(a_{21}a_{33} - a_{31}a_{23}) + a_{13}(a_{21}a_{32} - a_{22}a_{31})$$

Note that the value of a determinant is unaltered if the rows and columns are interchanged. See Sections on Vectors and Vector Calculus, where vector product and the curl of a vector are expressed as determinants.

## Matrices

The general set of simultaneous linear equations above can be written as

$$\begin{pmatrix} a_{11} & a_{12} & \cdots & a_{1n} \\ a_{21} & a_{22} & \cdots & a_{2n} \\ \vdots & & & \\ a_{m1} & a_{m2} & \cdots & a_{mn} \end{pmatrix} \begin{pmatrix} x_1 \\ x_2 \\ \vdots \\ x_n \end{pmatrix} = \begin{pmatrix} y_1 \\ y_2 \\ \vdots \\ y_m \end{pmatrix}$$

(an  $[m \times n]$  matrix)      (column vectors)

where the arrays of ordered coefficients are called *matrices*. One of the coefficients, or terms, is called an ‘element’ and a matrix is often denoted by the general element  $[a_{ij}]$ , where  $i$  indicates the row and  $j$  the column.

### Addition of matrices

If two matrices are of the *same* order  $m \times n$  then

$$[a_{ij}] + [b_{ij}] = [a_{ij} + b_{ij}]$$

### Scalar multiplication

If  $\lambda$  is a *scalar* number then

$$\lambda[a_{ij}] = [\lambda a_{ij}]$$

### Matrix multiplication

Multiplication of two matrices  $[a_{ij}]$ ,  $[b_{ij}]$  is possible *only* if the number of *columns* in  $[a_{ij}]$  is the same as the number of *rows* in  $[b_{ij}]$ . The product  $[c_{ij}]$  is given by

$$[c_{ij}] = \sum_{k=1}^n a_{ik} b_{kj}$$

Note

1. Matrix multiplication is not defined unless the two matrices have the appropriate number of rows and columns.
2. Matrix multiplication is generally non-commutative:  $AB \neq BA$

### The unit matrix

The unit (or identity) matrix, denoted by  $I$ , is a square ( $n \times n$ ) matrix with its diagonal elements equal to unity and all other elements zero. For example the  $3 \times 3$  unit matrix is

$$I = \begin{bmatrix} 1 & 0 & 0 \\ 0 & 1 & 0 \\ 0 & 0 & 1 \end{bmatrix}$$

If we have a square matrix  $A$  of order  $n$  and the unit matrix of the same order then

$$IA = AI = A$$

and in general, provided the matrix product is defined (see above), multiplying *any* matrix  $A$  by a unit matrix leaves  $A$  unchanged.

### The transpose of a matrix

If the rows and columns of a matrix are interchanged, a new matrix, called the *transpose matrix*, is obtained. The transpose of a matrix  $A$  is denoted by  $A^T$ . For example if

$$A = \begin{bmatrix} a_{11} & a_{12} \\ a_{21} & a_{22} \\ a_{31} & a_{32} \end{bmatrix}$$

then

$$A^T = \begin{bmatrix} a_{11} & a_{21} & a_{31} \\ a_{12} & a_{22} & a_{32} \end{bmatrix}$$

### The adjoint matrix

The adjoint of a matrix (denoted by  $\text{adj } A$ ) is defined as the *transpose of the matrix of the cofactors*, where the cofactors are as defined above (see Section on Determinants, p. 36).

### The inverse of a matrix

The inverse  $A^{-1}$  of a matrix  $A$  has the property that

$$A^{-1}A = AA^{-1} = I,$$

the unit matrix. It is evaluated as follows:

$$A^{-1} = \frac{\text{adj } A}{|A|},$$

where  $|A|$  is the determinant of  $A$ .

### Hermitian and unitary matrices

If a matrix  $A$  contains complex elements then the complex conjugate of  $A$  is found by taking the complex conjugate of the individual elements. A matrix  $A$  is said to be *Hermitian* if

$$\widetilde{A}^* = A$$

A *unitary* matrix is defined by the condition

$$A\widetilde{A}^* = I$$



## 2.18 Vector Calculus

### Differentiation of vectors (non-rotating axes)

$$\frac{d\mathbf{A}}{dt} = \hat{\mathbf{i}} \frac{dA_x}{dt} + \hat{\mathbf{j}} \frac{dA_y}{dt} + \hat{\mathbf{k}} \frac{dA_z}{dt}$$

$$\frac{d(\mathbf{A} \cdot \mathbf{B})}{dt} = \left( \mathbf{A} \cdot \frac{d\mathbf{B}}{dt} \right) + \left( \frac{d\mathbf{A}}{dt} \cdot \mathbf{B} \right)$$

$$\frac{d(\mathbf{A} \times \mathbf{B})}{dt} = \left( \mathbf{A} \times \frac{d\mathbf{B}}{dt} \right) + \left( \frac{d\mathbf{A}}{dt} \times \mathbf{B} \right)$$

### Gradient of a scalar function

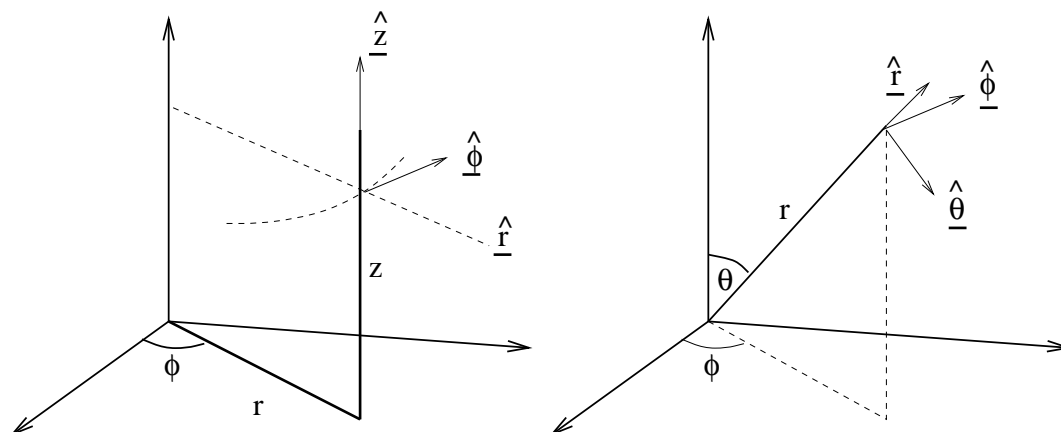

Figure 2.8: Cylindrical (left) and Spherical (right) polars.

#### CARTESIAN CO-ORDINATES

$$\nabla \equiv \hat{\mathbf{i}} \frac{\partial}{\partial x} + \hat{\mathbf{j}} \frac{\partial}{\partial y} + \hat{\mathbf{k}} \frac{\partial}{\partial z} \quad (\text{a vector operator}).$$

$\nabla U = \text{grad } U$ , where  $U$  is a scalar.  $\nabla U$  is a vector.

$$\nabla(U + V) = \nabla U + \nabla V \quad U, V \text{ scalars.}$$

$$\nabla(UV) = V(\nabla U) + (\nabla U)V$$

#### CYLINDRICAL CO-ORDINATES

$$\nabla \equiv \hat{\mathbf{r}} \frac{\partial}{\partial r} + \hat{\boldsymbol{\phi}} \frac{1}{r} \frac{\partial}{\partial \phi} + \hat{\mathbf{z}} \frac{\partial}{\partial z}$$

#### SPHERICAL POLAR CO-ORDINATES

$$\nabla \equiv \hat{\mathbf{r}} \frac{\partial}{\partial r} + \hat{\boldsymbol{\theta}} \frac{1}{r} \frac{\partial}{\partial \theta} + \hat{\boldsymbol{\phi}} \frac{1}{r \sin \theta} \frac{\partial}{\partial \phi}$$

## Divergence of a vector function

CARTESIAN CO-ORDINATES

$$\begin{aligned}\nabla \cdot \mathbf{A} &= \frac{\partial A_x}{\partial x} + \frac{\partial A_y}{\partial y} + \frac{\partial A_z}{\partial z} \\ &\equiv \operatorname{div} \mathbf{A} \quad \text{a scalar}\end{aligned}$$

CYLINDRICAL POLAR CO-ORDINATES

$$\nabla \cdot \mathbf{A} = \frac{1}{r} \frac{\partial}{\partial r}(rA_r) + \frac{1}{r} \frac{\partial A_\phi}{\partial \phi} + \frac{\partial A_z}{\partial z}$$

SPHERICAL POLAR CO-ORDINATES

$$\nabla \cdot \mathbf{A} = \frac{1}{r^2} \frac{\partial}{\partial r}(r^2 A_r) + \frac{1}{r \sin \theta} \frac{\partial}{\partial \theta}(A_\theta \sin \theta) + \frac{1}{r \sin \theta} \frac{\partial A_\phi}{\partial \phi}$$

## Curl of a vector function

CARTESIAN CO-ORDINATES

$$\begin{aligned}\nabla \times \mathbf{A} \equiv \operatorname{curl} \mathbf{A} &= \begin{vmatrix} \hat{\mathbf{i}} & \hat{\mathbf{j}} & \hat{\mathbf{k}} \\ \frac{\partial}{\partial x} & \frac{\partial}{\partial y} & \frac{\partial}{\partial z} \\ A_x & A_y & A_z \end{vmatrix} \\ &\equiv \left( \frac{\partial A_z}{\partial y} - \frac{\partial A_y}{\partial z} \right) \hat{\mathbf{i}} + \left( \frac{\partial A_x}{\partial z} - \frac{\partial A_z}{\partial x} \right) \hat{\mathbf{j}} + \left( \frac{\partial A_y}{\partial x} - \frac{\partial A_x}{\partial y} \right) \hat{\mathbf{k}}\end{aligned}$$

CYLINDRICAL POLAR CO-ORDINATES

$$\begin{aligned}\nabla \times \mathbf{A} &= \frac{1}{r} \begin{vmatrix} \hat{\mathbf{r}} & r\hat{\phi} & \hat{\mathbf{z}} \\ \frac{\partial}{\partial r} & \frac{\partial}{\partial \phi} & \frac{\partial}{\partial z} \\ A_r & rA_\phi & A_z \end{vmatrix} \\ &\equiv \left( \frac{1}{r} \frac{\partial A_z}{\partial \phi} - \frac{\partial A_\phi}{\partial z} \right) \hat{\mathbf{r}} + \left( \frac{\partial A_r}{\partial z} - \frac{\partial A_z}{\partial r} \right) \hat{\phi} + \frac{1}{r} \left( \frac{\partial}{\partial r}(rA_\phi) - \frac{\partial A_r}{\partial \phi} \right) \hat{\mathbf{z}}\end{aligned}$$

SPHERICAL POLAR CO-ORDINATES

$$\begin{aligned}\nabla \times \mathbf{A} &= \frac{1}{r^2 \sin \theta} \begin{vmatrix} \hat{\mathbf{r}} & r\hat{\theta} & r \sin \theta \hat{\phi} \\ \frac{\partial}{\partial r} & \frac{\partial}{\partial \theta} & \frac{\partial}{\partial \phi} \\ A_r & rA_\theta & rA_\phi \sin \theta \end{vmatrix} \\ &\equiv \frac{1}{r \sin \theta} \left( \frac{\partial}{\partial \theta}(A_\phi \sin \theta) - \frac{\partial A_\theta}{\partial \phi} \right) \hat{\mathbf{r}} + \frac{1}{r} \left( \frac{1}{\sin \theta} \frac{\partial A_r}{\partial \phi} - \frac{\partial}{\partial r}(rA_\phi) \right) \hat{\theta} \\ &\quad + \frac{1}{r} \left( \frac{\partial}{\partial r}(rA_\theta) - \frac{\partial A_r}{\partial \theta} \right) \hat{\phi}\end{aligned}$$

## Relations

$$\begin{aligned}\nabla \times (\nabla U) &\equiv 0 \\ \nabla \cdot (\nabla \times \mathbf{A}) &\equiv 0 \\ \nabla \cdot (\nabla U) &\equiv \nabla^2 U = \frac{\partial^2 U}{\partial x^2} + \frac{\partial^2 U}{\partial y^2} + \frac{\partial^2 U}{\partial z^2} \\ \nabla \times (\nabla \times \mathbf{A}) &= \nabla(\nabla \cdot \mathbf{A}) - \nabla^2 \mathbf{A}\end{aligned}$$

## The Laplacian operator $\nabla^2$

CARTESIAN CO-ORDINATES

$$\nabla^2 = \frac{\partial^2}{\partial x^2} + \frac{\partial^2}{\partial y^2} + \frac{\partial^2}{\partial z^2}$$

CYLINDRICAL POLAR CO-ORDINATES

$$\begin{aligned}\nabla^2 &= \frac{1}{r} \left[ \frac{\partial}{\partial r} \left( r \frac{\partial}{\partial r} \right) + \frac{\partial}{\partial \phi} \left( \frac{1}{r} \frac{\partial}{\partial \phi} \right) + \frac{\partial}{\partial z} \left( r \frac{\partial}{\partial z} \right) \right] \\ &= \frac{\partial^2}{\partial r^2} + \frac{1}{r} \frac{\partial}{\partial r} + \frac{1}{r^2} \frac{\partial^2}{\partial \phi^2} + \frac{\partial^2}{\partial z^2}\end{aligned}$$

SPHERICAL POLAR CO-ORDINATES

$$\begin{aligned}\nabla^2 &= \frac{1}{r^2 \sin \theta} \left[ \frac{\partial}{\partial r} \left( r^2 \sin \theta \frac{\partial}{\partial r} \right) + \frac{\partial}{\partial \theta} \left( \sin \theta \frac{\partial}{\partial \theta} \right) + \frac{\partial}{\partial \phi} \frac{1}{\sin \theta} \frac{\partial}{\partial \phi} \right] \\ &= \frac{\partial^2}{\partial r^2} + \frac{2}{r} \frac{\partial}{\partial r} + \frac{1}{r^2} \frac{\partial^2}{\partial \theta^2} + \frac{\cot \theta}{r^2} \frac{\partial}{\partial \theta} + \frac{1}{r^2 \sin^2 \theta} \frac{\partial^2}{\partial \phi^2}\end{aligned}$$

## Integral theorems

DIVERGENCE/GAUSS' THEOREM

$$\oiint_S \mathbf{A} \cdot d\mathbf{s} = \iiint_V (\nabla \cdot \mathbf{A}) dV$$

STOKES' THEOREM

$$\oint_L \mathbf{A} \cdot d\mathbf{l} = \iint_S (\nabla \times \mathbf{A}) \cdot d\mathbf{s}$$

GREEN'S THEOREM

$$\oiint_S (\theta \nabla \phi - \phi \nabla \theta) \cdot d\mathbf{s} = \iiint_V (\theta \nabla^2 \phi - \phi \nabla^2 \theta) dV$$

## 2.19 Fourier Series

If a function  $f(t)$  is periodic in  $t$  with period  $T$ , (i.e.  $f(t + nT) = f(t)$  for any integer  $n$  and all  $t$ ), then

$$f(t) = \frac{a_0}{2} + \sum_{n=1}^{\infty} \left[ a_n \cos\left(\frac{2\pi nt}{T}\right) + b_n \sin\left(\frac{2\pi nt}{T}\right) \right]$$

where

$$a_0 = \frac{2}{T} \int_0^T f(t) dt$$

$$a_n = \frac{2}{T} \int_0^T f(t) \cos\left(\frac{2\pi nt}{T}\right) dt$$

$$b_n = \frac{2}{T} \int_0^T f(t) \sin\left(\frac{2\pi nt}{T}\right) dt$$

Notes:

1.  $t$  can be any continuous variable, *not necessarily time*.
2. The function  $f(t)$  is a continuous function from  $t = -\infty$  to  $t = +\infty$ . For some functions  $t = 0$  may be so chosen as to produce a simpler series in which either *all*  $a_n = 0$  or *all*  $b_n = 0$ , e.g. a 'square' wave. See Fig. 2.9.

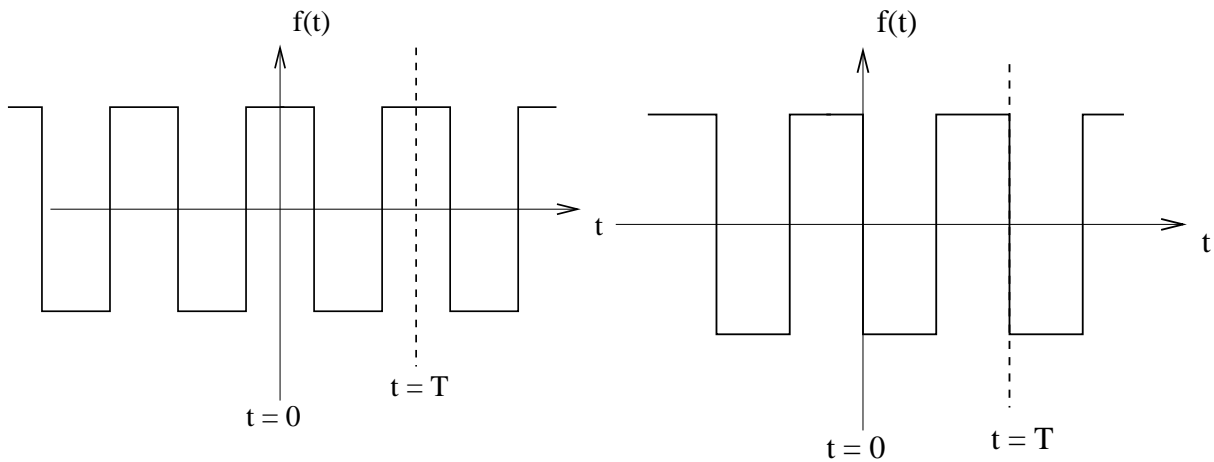

Figure 2.9: Even function (left),  $f(+t) = f(-t)$  so  $b_n = 0$ . Odd function (right),  $f(+t) = -f(-t)$  so  $a_n = 0$

## Complex form of the Fourier series

$$f(t) = \sum_{n=-\infty}^{\infty} C_n \exp\left(i\frac{2\pi nt}{T}\right)$$

where

$$\begin{aligned} C_n &= \frac{1}{T} \int_0^T f(t) \exp\left(-i\frac{2\pi nt}{T}\right) dt \\ &= \frac{1}{2}(a_n - ib_n) \text{ for } n > 0 \\ &= \frac{1}{2}(a_n + ib_n) \text{ for } n < 0 \end{aligned}$$

$$\Re[C_n] = \frac{1}{T} \int_0^T f(t) \cos\left(\frac{2\pi nt}{T}\right) dt$$

$$\Im[C_n] = -\frac{1}{T} \int_0^T f(t) \sin\left(\frac{2\pi nt}{T}\right) dt$$

## Average value of the product of two periodic functions

$$\overline{f_1(t)f_2(t)} = \sum_{n=-\infty}^{\infty} (C_1)_n (C_2)_n$$

where the 'bar' means 'averaged over a complete period'.

$$\begin{aligned} \overline{\{f(t)\}^2} &= \sum_{n=-\infty}^{\infty} C_n C_{-n} = \sum_n C_n C_n^* = \sum_n |C_n|^2 \\ &= \frac{a_0^2}{4} + \sum_{n=1}^{\infty} \frac{1}{2}(a_n^2 + b_n^2) \end{aligned}$$

## Fourier transforms

For non-periodic functions:

$$\mathcal{F}(\omega) = \int_{-\infty}^{\infty} f(t) \exp[-i\omega t] dt \quad \text{Fourier transform}$$

$$f(t) = \frac{1}{2\pi} \int_{-\infty}^{\infty} \mathcal{F}(\omega) \exp[i\omega t] d\omega \quad \text{inverse Fourier transform}$$

The functions  $f(t)$  and  $\mathcal{F}(\omega)$  are called a Fourier transform pair. Some examples are given in Figure 2.10.

TOP HAT FUNCTION

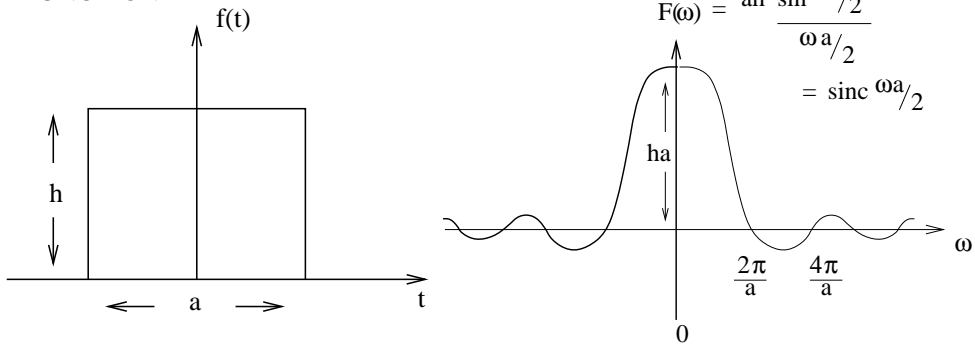

GAUSSIAN FUNCTION

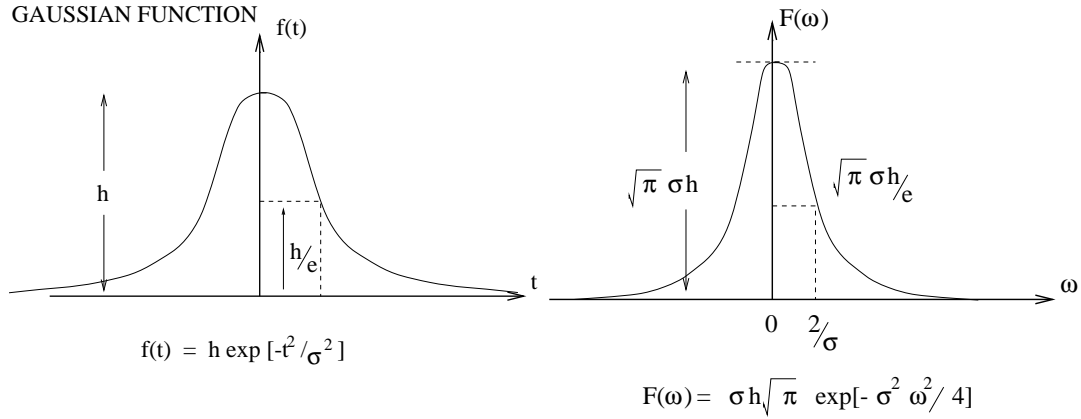

DELTA FUNCTION

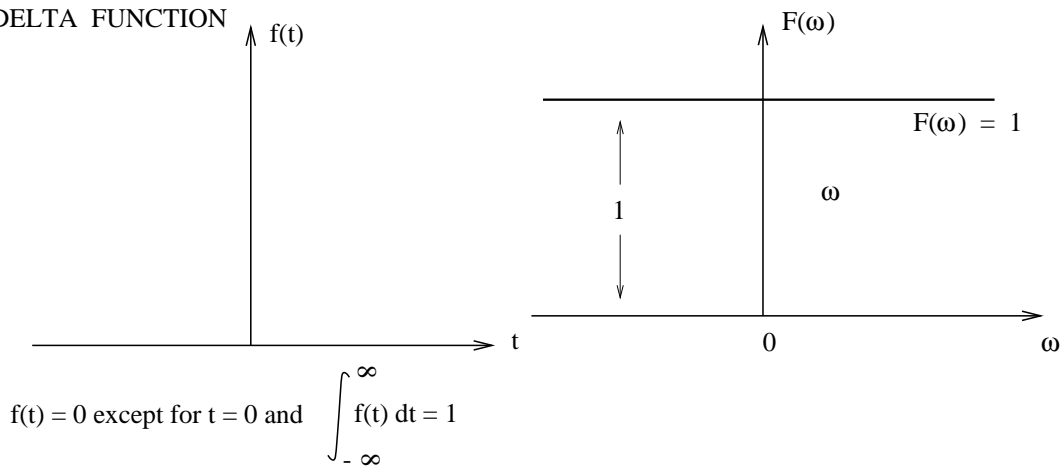

Figure 2.10: Examples of Fourier transforms

## 2.20 Statistics

### Mean and RMS

If  $x_1, x_2, \dots, x_n$  are  $n$  values of some quantity, then

The *arithmetic mean* is

$$\bar{x} = \frac{1}{n} \sum_i^n x_i = \frac{1}{n} (x_1 + x_2 + \dots + x_n)$$

The *geometric mean* is

$$x_{\text{GM}} = \left( \prod_i^n x_i \right)^{1/n} = \sqrt[n]{x_1 \times x_2 \times \dots \times x_n}$$

The *root-mean-square (RMS)* is

$$RMS = \sqrt{\frac{1}{n} \sum_i^n x_i^2} = \sqrt{\frac{x_1^2 + x_2^2 + \dots + x_n^2}{n}}$$

### Permutations

Permutations of  $n$  things taken  $r$  at a time

$$= n(n-1)(n-2) \dots (n-r+1) = \frac{n!}{(n-r)!} \equiv {}^n P_r$$

### Combinations

Combinations of  $n$  things taken  $r$  at a time

$$= \frac{n!}{r!(n-r)!} \equiv {}^n C_r$$

Note that in a permutation the *order* in which selection is made is significant. Thus  $A\underbrace{BC}DEFG$  is a different *permutation*, but the same *combination*, as  $A\underbrace{CB}DEFG$ .

### Binomial distribution

Random variables can have *two* values A or B (e.g. heads or tails in the case of a toss of a coin). Let the probability of A occurring =  $p$ , the probability of B occurring =  $(1-p) = q$ . The probability of A occurring  $m$  times in  $n$  trials is

$$p_m(A) = \frac{n!}{m!(n-m)!} p^m q^{n-m} \quad \text{N.B. } 0! = 1$$

This is the  $m^{\text{th}}$  term in the binomial expansion of  $(p+q)^n$ .

## Poisson distribution

Events occurring with average frequency  $\nu$  but randomly distributed, in time for example (e.g. radioactive decay of nuclei, shot noise, goals, floods and horse kicks!). Probability of  $m$  events occurring in time interval  $T$  is

$$p_m(T) = \frac{(\nu T)^m}{m!} \exp(-\nu T)$$

## Normal distribution (Gaussian)

For a continuous variable which is randomly distributed about a mean value  $\mu$  with standard deviation  $\sigma$ , (e.g. random experimental errors of measurement), the probability that a measurement lies between  $x$  and  $x + dx$  is

$$p(x)dx = \frac{1}{\sigma\sqrt{2\pi}} \exp\left(-\frac{(x-\mu)^2}{2\sigma^2}\right) dx.$$

The quantity  $\sigma^2$  is also known as the *variance*.

Given a sample of  $N$  measurements, the mean value of the sample,  $\bar{x}$ , is an unbiased estimator of  $\mu$ , and the *sample standard deviation*,  $s_{N-1} = \sqrt{\frac{\sum_i (x_i - \bar{x})^2}{N-1}}$  is an unbiased estimator of  $\sigma$ .

The *standard error on the mean* (SEM) is:

$$\sigma_{\bar{x}} = \frac{s_{N-1}}{\sqrt{N}}.$$

For large  $N$ , the difference  $\bar{x} - \mu$  is itself a normal distribution with mean 0 and standard deviation  $\sigma_{\bar{x}}$ .



---

# Selected Physics Formulae

---

<b>3.1</b>	<b>Equations of Electromagnetism . . . . .</b>	<b>48</b>
<b>3.2</b>	<b>Equations of Relativistic Kinematics and Mechanics . . . . .</b>	<b>49</b>
<b>3.3</b>	<b>Thermodynamics and Statistical Physics . . . . .</b>	<b>50</b>

## 3.1 Equations of Electromagnetism

### Definitions

$$\begin{aligned}
 \mathbf{B} &= \mu_r \mu_0 \mathbf{H} = \text{magnetic field} \\
 \mathbf{D} &= \epsilon_r \epsilon_0 \mathbf{E} = \text{electric displacement} \\
 \mathbf{E} &= \text{electric field} \\
 \mathbf{J} &= \text{conduction current density} \\
 \rho &= \text{charge density}
 \end{aligned}$$

where  $\epsilon_r$  and  $\mu_r$  are the relative permittivity and permeability respectively. The definitions for  $\mathbf{B}$  and  $\mathbf{D}$  are for linear, isotropic, homogeneous media.

### Biot-Savart law

$$d\mathbf{B} = \frac{\mu_0}{4\pi} I \frac{d\mathbf{l} \times \mathbf{r}}{r^3}$$

### Maxwell's equations

These are four differential equations linking the space- and time-derivatives of the electromagnetic field quantities:

$$\begin{aligned}
 \nabla \cdot \mathbf{B} &= 0 & \nabla \times \mathbf{E} + \frac{\partial \mathbf{B}}{\partial t} &= 0 \\
 \nabla \cdot \mathbf{D} &= \rho & \nabla \times \mathbf{H} - \frac{\partial \mathbf{D}}{\partial t} &= \mathbf{J}
 \end{aligned}$$

They can also be expressed in integral form:

$$\begin{aligned}
 \int_S \mathbf{B} \cdot d\mathbf{S} &= 0 \\
 \int_S \mathbf{D} \cdot d\mathbf{S} &= \int_V \rho d\tau \\
 \oint \mathbf{E} \cdot d\mathbf{l} &= - \int \frac{\partial \mathbf{B}}{\partial t} \cdot d\mathbf{S} \\
 \oint \mathbf{H} \cdot d\mathbf{l} &= \int_S \left( \mathbf{J} + \frac{\partial \mathbf{D}}{\partial t} \right) \cdot d\mathbf{S}
 \end{aligned}$$

$$\text{Energy density in an electric field} = \frac{\epsilon_r \epsilon_0 E^2}{2}$$

$$\text{Energy density in a magnetic field} = \frac{\mu_r \mu_0 H^2}{2}$$

Velocity of plane waves in a linear, homogeneous

$$\text{and isotropic medium } u = (\mu_r \epsilon_r \mu_0 \epsilon_0)^{-1/2}$$

## 3.2 Equations of Relativistic Kinematics and Mechanics

### Definitions

$E$  = energy;

$m_0$  = rest mass

$p$  = linear momentum

$v$  = relative velocity of reference frames in  $x, x'$  direction

$\gamma = 1/\sqrt{(1 - v^2/c^2)}$

### Lorentz transformations

Two inertial frames,  $S$  and  $S'$ , are such that  $S'$  moves relative to  $S$  along the positive  $x$  direction, with velocity  $v$  as measured in  $S$ ; the origins coincide at time  $t = t' = 0$ . The Lorentz transformations are:

$$\begin{aligned}x &= \gamma(x' + vt') & x' &= \gamma(x - vt) \\t &= \gamma\left(t' + \frac{vx'}{c^2}\right) & t' &= \gamma\left(t - \frac{vx}{c^2}\right) \\E^2 &= (pc)^2 + (m_0c^2)^2\end{aligned}$$

### 3.3 Thermodynamics and Statistical Physics

#### Maxwell speed distribution

For a gas, molecular weight  $m$ , in thermodynamic equilibrium at temperature  $T$ , the fraction  $f(v) dv$  of molecules with speed in the range  $v \rightarrow v + dv$  is

$$f(v) dv = 4\pi v^2 \left( \frac{m}{2\pi k_B T} \right)^{3/2} \exp \left[ -\frac{mv^2}{2k_B T} \right] dv$$

#### Thermodynamic variables

Helmholtz free energy:	$F = U - TS$
Gibbs function:	$G = U - TS + PV$
Enthalpy:	$H = U + PV$

#### Maxwell's thermodynamic relations

$$\left( \frac{\partial T}{\partial V} \right)_S = - \left( \frac{\partial P}{\partial S} \right)_V \quad \left( \frac{\partial T}{\partial P} \right)_S = \left( \frac{\partial V}{\partial S} \right)_P$$

$$\left( \frac{\partial V}{\partial T} \right)_P = - \left( \frac{\partial S}{\partial P} \right)_T \quad \left( \frac{\partial S}{\partial V} \right)_T = \left( \frac{\partial P}{\partial T} \right)_V$$

#### Statistical physics

Partition function:  $Z = \sum_i e^{-\beta E_i} = \sum_i e^{-E_i/kT}$

Helmholtz free energy:  $F = -kT \ln Z$

Entropy:  $S = k \ln \Omega = -k \sum_i p_i \ln p_i$

#### Blackbody radiation

The energy emitted per unit area, per unit time, into unit solid angle, in the frequency range  $\nu \rightarrow \nu + d\nu$  is

$$B(T, \nu) = \frac{2h\nu^3}{c^2} \frac{1}{(\exp[h\nu/kT] - 1)}$$

## Quantum statistics

Distribution function:

$$f(E_s) = \left[ \exp \left( \frac{(E_s - \mu)}{kT} \right) \pm 1 \right]^{-1}$$

Fermi-Dirac: + sign;  $\mu = E_F$

Bose-Einstein: - sign

N.B. for photons  $\mu = 0$ .

For high energies  $E \gg kT$  both distributions reduce to the classical Maxwell-Boltzmann distribution.

## Bibliography

*Tables of Physical and Chemical constants*, compiled by G. W. C. Kaye & T. H. Laby, Longmans.

*Allen's Astrophysical Quantities*, ed A. C. Cox, AIP Press, Springer

*Handbook of Space Astronomy and Astrophysics*, M. V. Zombeck, Cambridge University Press.

*Electricity and Magnetism*, Chapter 13, W. J. Duffin, McGraw Hill.

*Special Relativity*, A. P. French, Van Nostrand.

*Mathematical methods for Science Students*, 2nd. edition, G. Stephenson, Longmans.

*The Elements*, J. Emsley, Clarendon Press.

*Table of Isotopes*, C. M. Lederer, J. M. Hollander & I. Perlman, John Wiley & Sons.

*Handbook of mathematical functions*, Eds M. Abramowitz & I. E. Stegun, Dover Publications. Contains many useful mathematical formulae and tables of special functions.

*An introduction to applied mathematics*, Jaeger, Oxford University Press.

*Mathematics of Physics and Chemistry*, Margenau & Murphy, van Nostrand.

*Tables of integrals, series and products*, I. S. Gradshteyn & I. M. Ryzhik, Academic Press. Contains virtually every integral ever solved.