



## The Questions

1.

- a) The following events in power systems lead to dynamic response of the system quantities such as voltage, current and frequency. Please associate the time scale of these events in appropriate unit.
- i) Network switching surges
  - ii) Transient stability
  - iii) Boiler and long term dynamics
- [3]
- b) Why do hydro turbines have non-minimum phase transfer characteristic between the water gate position and power output? How does one overcome this problem through proper control?
- [5]
- c) A 3-phase, star connected, 23.5 kV ( $V_t$ ) (line-line) 600 MVA alternator is connected to grid operating at 50 Hz. The resistance is negligible and the synchronous reactance ( $X_s$ ) is 2.0 Ohm. Derive the power angle relationship as a function of terminal voltage ( $V_t$ ), excitation voltage ( $E_{fd}$ ), reactance ( $X_s$ ) and power angle ( $\delta$ ) and subsequently solve the following
- [5]
- i) Find the excitation voltage (line-line) and the machine angle delta when the generator is delivering full load at 0.85 power factor lagging.
- [4]
- ii) Keeping the excitation voltage at the value obtained in (i), if the prime mover power is gradually increased the generator will continue to deliver increased MW before the steady state stability limit is reached. Compute the stability limit (in terms of MW).
- [3]

- a) Starting from the inertia constant  $J$  ( $\text{Kg-m}^2$ ), rated VA as  $VA_{\text{base}}$ , basic torque and angle equations in a rotational system, derive the following swing equations of a synchronous generator connected to the grid:

$$\frac{d\delta}{dt} = \omega_r - \omega_s$$

$$\frac{2H}{\omega_s} \frac{d\omega_r}{dt} = P_{\text{mech}} - P_{\text{elec}} - D(\omega_r - \omega_s)$$

$\delta$  = is the angle of the rotor with respect to a synchronously rotating reference frame;

$\omega_r, \omega_s$  : speed of the rotor and synchronous reference frame respectively in rad/sec.

$P_{\text{mech}}, P_{\text{elec}}$  : mechanical power input and electrical power output in p.u. respectively

$H$  = H-constant in seconds

$D$  : mechanical damping co-efficient in p.u.-sec/rad

[8]

- b) The moment of inertia of a generator-turbine mass is 30,000  $\text{Kg-m}^2$ . The generator has a rating of 600 MVA and operates at 3000 RPM. Find the

i) stored energy

[3]

ii) H-constant (H)

[2]

iii) mechanical starting time ( $T_M$ )

[1]

- c) In power system control study, the parameters and variables of a machine are generally expressed in a synchronously rotating machine reference co-ordinate system dq (q-axis leading d axis by 90 degree). The network variables and quantities are expressed in a synchronously rotating network reference co-ordinate system QD (Q-axis leading D by 90 degree). The angular separation between the q-axis and Q-axis is  $\delta$  (q leading Q).

If the network voltage at the machine terminal is expressed as  $\bar{V}_t = V_Q + jV_D = V_t e^{j\theta}$ , show that in the machine reference co-ordinates the same voltage can be expressed as

$$V_q + jV_d = V_t e^{-j(\delta-\theta)}$$

[6]

3

- a) List and briefly describe the major components in an excitation system. [10]
- b) The simplified model of a fast excitation system is shown in Figure 3.1. It is required to produce a 3.5 p.u. of  $E_{fd}$  in the steady state. The voltage regulator has a gain of 250 and time constant of 0.05 s. Compute the reference voltage that needs to be set in order to maintain a terminal voltage of 1.03 p.u.

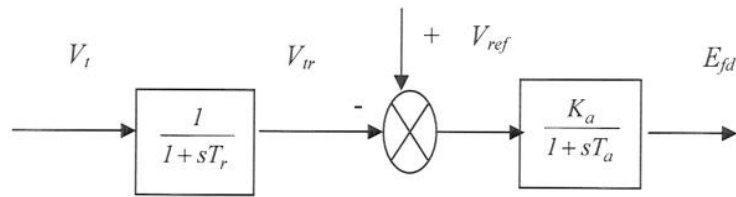

3.1 Block Diagram of a Fast Excitation System

[5]

- c) Briefly describe the voltage control capability of on-load tap changing transformer and shunt capacitor.

[5]

4

- a) List the various frequency control regimes with their associated time scales of operation. [3]
- b) A power system has combined generation inertia constant  $M (= 2H)$  (sec) and load damping co-efficient of  $D$  (p.u power per p.u change in frequency). It is equipped with a primary frequency control feature. For an increase in system load ( $\Delta P_L$  in p.u), derive an expression for the steady state frequency deviation in p.u for the following two situations
- i) without governor droop control [5]
- ii) with governor droop control having droop  $R$  [4]
- c) A small 60 Hz system consists of 4 identical 500 MVA generating units feeding a total load of 1,020 MW. The  $H$  constant of each unit is 5.0 seconds on a 500 MVA base. The load varies by 1.5% for 1% change in frequency. For a sudden drop in load by 20 MW answer the following
- i) Compute the equivalent  $M$ ,  $D$  and express load variation on 2000 MVA base [6]
- ii) Find the frequency deviation in the steady state assuming no speed governing option. [2]

5

- a) Describe the basic components and operating principle of any one of three classes of relay technology. [5]
- b) Distinguish between dependability and security of a relay [4]
- c) The performance of an over current relay was monitored for a period of three years. It was found that the relay operated 33 times, out of which 29 were correct trips. If the relay failed to issue trip decisions on 3 occasions, compute dependability, security and reliability of the relay as a percentage. [6]
- d) How is selectivity achieved in transformer differential protection? [5]

6

- a) A 1200/5 C400 current transformer (CT) is connected to a relay with a burden of  $0.7 \Omega$ . The secondary resistance of the CT is  $0.61 \Omega$ . A secondary current of 105 A flows through the relay coil.
- i) For this secondary current, is the CT still expected to behave in a linear manner? Justify your answer. [3]
  - ii) The magnetising impedance (as referred to the secondary of the CT) is  $5 \text{ k} \Omega$ . Calculate the % ratio error [4]
- b) In what ways does a high ratio error affect the quality of CT's measurement? [3]
- c) What are the performance requirements of a protection grade CT? How do they differ from a measurement grade CT? [4]
- d) Draw the equivalent circuit for a capacitively coupled voltage transformer (CCVT). What is the purpose of and required expression for the tuning inductor in this circuit? [6]

## The Solution

1.

- a) The following events in power systems lead to dynamic response of the system quantities such as voltage, current and frequency. Please associate the time scale of these events in appropriate unit
- i) Network switching surges
  - ii) Transient stability
  - iii) Boiler and long term dynamics

[3]

Answer

- i) Network switching surge in the range of a few microseconds to few hundred micro seconds [1]
- ii) Transient stability in the range of first few seconds (5 seconds) after the initiating event [1]
- iii) Boiler and long term dynamics: few tens of seconds to few tens of minutes [1]

- b) Why do hydro turbines have non-minimum phase transfer characteristic between water gate position and power output? How does one overcome this problem through proper control?

[5]

Answer

The Mechanics of power production in hydro turbine is characterised by the following relation

$$\Delta P_m = \left[ \frac{1 - T_w s}{1 + 0.5 T_w s} \right] \Delta G$$

$\Delta P_m, T_w, \Delta G$  are respectively mechanical power, water inertia constant and gate opening.

In water turbine it is the potential energy of water head when converted to kinetic energy at the lower elevation (end of penstock) hits the turbine blade. Kinetic energy is converted to mechanical energy that rotates the shaft. The mechanical power produced is proportional to the pressure and amount of water discharged.



The amount of water admitted is governed by the gate opening. There is a reverse relationship between the power production and gate opening because of drop of pressure due to sudden gate opening. This is characterized by non-minimum phase zero. This poses control problem and needs large transient governor droop compensation. Typically water inertia constant is few seconds.

[5]

- c) A 3-phase, star connected, 23.5 kV ( $V_t$ ) (line-line) 600 MVA alternator is connected to grid operating at 50 Hz. The stator resistance is negligible and synchronous reactance ( $X_s$ ) is 2.0 Ohm. Derive the power angle relationship as a function of terminal voltage ( $V_t$ ), excitation voltage ( $E_{fd}$ ), reactance ( $X_s$ ) and power angle ( $\delta$ ) and subsequently solve the following

[5]

Answer:

A synchronous machine is normally connected to a fixed voltage bus and operates at constant speed. There is a limit on the power that can be delivered by the machine to the system or the torque that can be applied to it when working as a motor. Analytical expressions for the steady state power transfer between the machine and the infinite bus or the torque developed by the machine are derived in terms of bus voltage, machine voltage and machine parameters on per phase basis. The per phase voltage, current and reactance are shown in the equivalent circuit:

Induced or excitation voltage  $E_{fd} = \bar{E} = E \angle \delta$ , Terminal voltage or infinite bus voltage:  $\bar{V}_t = V_t \angle 0$

Stator impedance:  $\bar{Z}_s = R_s + jX_s = Z_s \angle \theta_s$

The complex power delivered to infinite bus:

$$S = V_t I_s^* ;$$

$$I_s^* = \left| \frac{E - V_t}{Z_s} \right|^* = \frac{E}{Z_s} \angle \theta_s - \delta - \frac{V_t}{Z_s} \angle \theta_s$$

$$S = \frac{EV_t}{Z_s} \angle \theta_s - \delta - \frac{V_t^2}{Z_s} \cos \angle \theta_s$$

$$S = P + jQ;$$

$$P = \frac{EV_t}{Z_s} \cos(\theta_s - \delta) - \frac{V_t^2}{Z_s} \cos \theta_s \text{ watt/phase}$$

$$Q = \frac{EV_t}{Z_s} \sin(\theta_s - \delta) - \frac{V_t^2}{Z_s} \sin \theta_s \text{ VAR/phase}$$

when stator resistance is neglected (normally  $\frac{X_s}{R_s} > 400$ );

$$P_{3\phi} = 3 \frac{EV_t}{X_s} \sin \delta = P_{\max} \sin \delta \quad Q_{3\phi} = 3 \frac{EV_t}{X_s} \cos \delta - 3 \frac{V_t^2}{X_s}$$

When the voltages are expressed in line to line and the , the power flow equations are

$$P_{out} = \frac{EV_t}{X_s} \sin \delta = P_{\max} \sin \delta$$

$$Q_{out} = \frac{EV_t}{X_s} \cos \delta - \frac{V_t^2}{X_s}$$

[5]

- i) Find the excitation voltage (line-line) and the machine angle delta when the generator is delivering full load at 0.85 power factor lagging.

[4]

Answer:

Find the full load current from full MVA rating ( $\sqrt{3}V_t I_t = MVA$ ) at 0.85 pf lagging

The current is 14741 A at -31.78 degree taking  $V_t$  as reference

[1]

$$E_{fd} \angle \delta = V_t + j\sqrt{3}IX_s :$$

One can obtain  $E_{fd}=66.51$  kV and machine angle delta ( $\delta$ ) = 40.73 degree

[3]

- ii) Keeping the excitation voltage at the value obtained in (i), if the prime mover power is gradually increased the generator will continue to deliver increased MW before the steady state stability limit is reached. Compute the stability limit (in terms of MW).

[3]

Answer

Maximum power from power angle equation derived in (a) is  $\frac{E_{fd}V_t}{X_s}$  and occurs at machine angle 90 degree which is 781.5 MW; For delta of 40.73 degree , output power is 510.0 MW. The stability margin in MW is 781.5-510.0=271.5 MW

[3]

2

- a) Starting from the inertia constant  $J$  ( $\text{Kg-m}^2$ ), rated VA as  $VA_{\text{base}}$ , basic torque and angle equations in a rotational system, derive the following swing equations of a synchronous generator connected to the grid:

$$\frac{d\delta}{dt} = \omega_r - \omega_s$$

$$\frac{2H}{\omega_s} \frac{d\omega_r}{dt} = P_{\text{mech}} - P_{\text{elec}} - D(\omega_r - \omega_s)$$

$\delta$  = is the angle of the rotor with respect to a synchronously rotating reference frame

$\omega_r, \omega_s$  : speed of the rotor and synchronous reference frame respectively in rad/sec.

$P_{\text{mech}}, P_{\text{elec}}$  : mechanical power input and electrical power output in p.u. respectively

$H$  = H-constant in seconds

$D$  : mechanical damping co-efficient in p.u.-sec/rad

[8]

Answer:

It is known that the balance of torque (mechanical input ( $T_{\text{mech}}$ ) – electrical output ( $T_{\text{elec}}$ )) drive the generator dynamics. Let's assume that the combined inertia of the generator and prime mover is  $J$  ( $\text{Kg-m}^2$ ). If the rotational speed is  $\omega_m$  (rad/sec); the following equation of motion can be written

$$J \frac{d\omega_m}{dt} = T_a = T_{\text{mech}} - T_{\text{elec}}$$

Generator manufacturers provide machine inertia constant as  $H$  that is related to  $J$  as

$$H = \frac{1}{2} \frac{J\omega_{0m}^2}{VA_{\text{base}}} \quad (\text{Stored energy per rated VA at rated speed})$$

The substitution of this into above will yield following set of equations

$$\frac{2H}{\omega_{0m}^2} VA_{\text{base}} \frac{d\omega_m}{dt} = T_{\text{mech}} - T_{\text{elec}}$$

$$\frac{2H}{\omega_{0m}} VA_{\text{base}} \frac{d\omega_m}{dt} = P_{\text{mech}0} - P_{\text{elec}0}$$

Multiplying  $\omega_m$  by number of pole pairs will result electrical speed  $\omega_r$ ;  $\omega_{0m}$  accordingly will correspond to synchronous speed  $\omega_s$

The final equation will appear as:

$$\frac{2H}{\omega_s} \frac{d\omega_r}{dt} = P_{mech} - P_{elec}$$

The mechanical damping effect is to retard the acceleration; this can be included as a term proportional to speed deviation on the right side of the above equation

The resulting equation can be written as:

$$\frac{2H}{\omega_s} \frac{d\omega_r}{dt} = P_{mech} - P_{elec} - D(\omega_r - \omega_s)$$

The angle equation: The rotor rotates at speed  $\omega_r$ ; the angle ( $\delta$ ) of the rotor at any point of time  $t$  with respect to a synchronously rotating reference speed  $\omega_s$  is

$$\delta(t) = (\omega_r - \omega_s)t + \delta_0$$

The initial rotor position at time  $t = 0$  is  $\delta_0$

The rate of change of angle is therefore

$$\frac{d\delta}{dt} = \omega_r - \omega_s$$

These two differential equations are known as swing equations

$$\frac{d\delta}{dt} = \omega_r - \omega_s$$

$$\frac{2H}{\omega_s} \frac{d\omega_r}{dt} = P_{mech} - P_{elec} - D(\omega_r - \omega_s)$$

Sometime another constant  $M = \frac{2H}{\omega_s}$  is also used in swing equation.

[8]

- b) The moment of inertia of a generator-turbine mass is 30,000 Kg-m<sup>2</sup>. The generator has a rating of 600 MVA and operates at 3000 RPM. Find the
- i) stored energy [3]
  - ii) H-constant (H) [2]
  - iii) mechanical starting time (T<sub>M</sub>) [1]

Answer:

- i) The stored energy =  $\frac{1}{2} J \omega^2 = 0.5 * 30,000 * (2\pi N/60)^2 = 1480$  Mega Joules [3]
  - ii) H = Stored Energy( MJ)/rated MVA = 2.46 seconds [2]
  - iii) Mechanical starting time T<sub>M</sub>= 2H = 4.92 seconds [1]
- c) In power system control study, the parameters and variables of a machine are generally expressed in a synchronously rotating machine reference co-ordinate system dq (q-axis leading d axis by 90 degree). The network variables and quantities are expressed in a synchronously rotating network reference co-ordinate system QD (Q-axis leading D by 90 degree). The angular separation between the q-axis and Q-axis is  $\delta$  (q leading Q).
- If the network voltage at the machine terminal is expressed as  $\bar{V}_t = V_Q + jV_D = V_t e^{j\theta}$ ; show that in the machine reference co-ordinates, the same voltage can be expressed as
- $$V_q + jV_d = V_t e^{-j(\delta-\theta)}$$
- [6]

Let us first resolve  $V/\theta$  along the network reference frame.

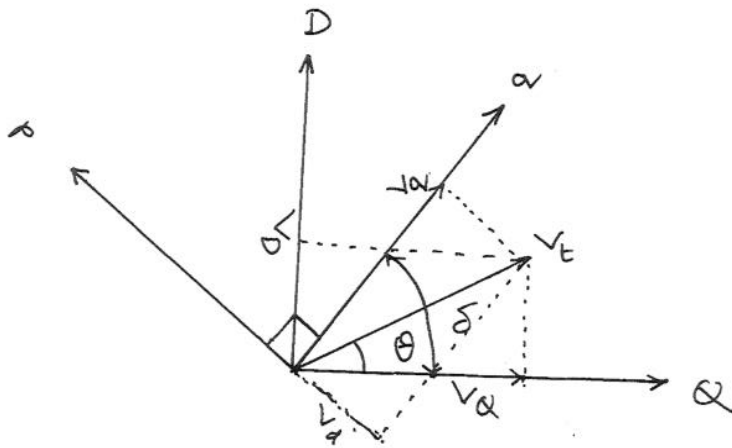

$$V_Q = V_T \cos \theta; \quad V_D = V_T \sin \theta.$$

$$V_Q + jV_D = V_T e^{j\theta}$$

Resolving  $V_Q$  and  $V_D$  along machine reference d-q axis produce

$$V_q = V_Q \cos \delta + V_D \sin \delta$$

$$V_d = -V_Q \sin \delta + V_D \cos \delta$$

The expression for  $V_q$  and  $V_d$  can be expressed in compact form as:

$$V_q + jV_d = (V_Q + jV_D) e^{-j\delta} = V_T e^{-j(\delta - \theta)}$$

on substituting  $V_Q + jV_D = V_T e^{j\theta}$

[6]

3

- a) List and briefly describe the major components in an excitation system.

[10]

Answer:

The major functional blocks of a generic excitation system are

- (i) exciter
- (ii) voltage regulator
- (iii) voltage and current sensor
- (iv) power system stabilizer
- (v) limiters and protection circuits

[2.5]

Exciter

This block provides DC power to the synchronous machine field winding, constituting the power stage of the excitation system.

Regulator

It processes and amplifies input control signals to a level and form appropriate for control of the exciter. This includes regulating and excitation system stabilising function (rate feedback and lead-lag compensation).

Voltage and current sensor

Senses generator terminal voltage and currents and feed to the regulator block for voltage regulation and load current compensation.

Power system stabilizer

This block provides an additional input signal to the regulator to damp power system oscillations. Some commonly used input signals are rotor speed deviation, accelerating power and frequency deviation.

Limiter and protective circuits

These include a wide array of control and protective functions that ensure that the capability limits of the exciter and synchronous generator are not exceeded. Some of the commonly used functions are the field current limiter, maximum excitation limiter, terminal voltage limiter, volt/Hz regulator and protection and under excitation limiter. These are normally distinct circuits and their output signals may be applied to the excitation system at various locations as a summing input or a gated input.

[7.5]



- b) The simplified model of a fast excitation system is shown in figure 3.1. It is required to produce a 3.5 p.u. of  $E_{fd}$  in the steady state. The voltage regulator has a gain of 250 and time constant of 0.05 s. Compute the reference voltage that needs to be set in order to maintain a terminal voltage of 1.03 p.u.

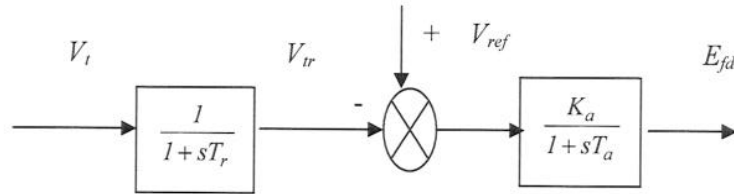

3.1 Block Diagram of a Fast Excitation System

[5]

Answer:

The students can write down two differential equations from the block diagram and set the derivative terms to zeros. On solving the algebraic equations for the parameters given, the required reference voltage ( $V_{ref}$ ) will be 1.044 p.u.

- c) Briefly describe the voltage control capability of on-load tap changing transformer and shunt capacitor.

[5]

Answer:

The students are expected to describe what OLTC is and how it functions. They are expected to cover the following points such as it

- provides discrete voltage control
- can be on-load or off-load
- always absorbs reactive power as the leakage impedance is reactive which is proportional to the square of its rating.

For a transformer with  $X_T$  p.u. and full load rating  $3VI_{rated}$

The var absorbed

$$X_T(\Omega) = VX_T(p.u.) / I_{rated}$$

$$3I^2 X_T(\Omega) = 3I^2 VX_T(p.u.) / I_{rated} = 3I^2 V^2 X_T(p.u.) / VI_{rated}$$

$$\left( \frac{VA_{load}}{VA_{rated}} \right)^2 X_T(p.u.)$$

On shunt capacitor they are expected to state that the amount of voltage support is proportional to the square of the voltage. It is very effective when the line is loaded beyond surge impedance loading. They can also illustrate how the line to ground capacitance of long line EHV line offers MVAR and depending on power loading it can be quite beneficial too.

[5]

4

- a) List the various frequency control regimes with their associated time scales of operation.

[3]

Answer:

Primarily major power system adopts to frequency control regimes; Primary frequency control with governor (10 seconds to 30 seconds); Secondary control with load reference point activated by AGC/LFC (30 seconds to 30 minutes). Some grid operators also have tertiary control which is manual and mainly to ensure enough margin for secondary control.

[3]

- b) A power system has combined generation inertia constant  $M$  ( $= 2H$ ) (sec) and load damping co-efficient of  $D$  (p.u power per p.u change in frequency). It is equipped with a primary frequency control feature. For an increase in system load ( $\Delta P_L$  in p.u), derive an expression for steady state frequency deviation in p.u for the following two situations

- i) without governor droop control

[5]

Answer

Any balance between the generation and demand will give rise to the dynamic response of the system. Let's consider a generator with combined inertia constant  $M$ . The balance between input mechanical power and output electrical power (in p.u) will govern the drive the turbine governed by the following equation:

$$P_{mech} - P_{elec} = Ms\omega_r$$

The perturbation of the above equation will result in

$$\Delta P_{mech} - \Delta P_{elec} = Ms\Delta\omega_r$$

Change in electrical power can be factored into two components as

$$\Delta P_{elec} = \Delta P_L + D\Delta\omega_r$$

D is known as load damping constant that represents frequency sensitivity component of load. Substituting the expression for  $\Delta P_{elec}$  into the expression for dynamic response equation one gets

$$\Delta P_m - \Delta P_L - D\Delta\omega_r = Ms\Delta\omega_r .$$

Rearranging the term, the following expression is obtained.

$$\Delta\omega_r = \frac{\Delta P_m - \Delta P_L}{Ms + D}$$

This is shown in the following block diagram. The perturbation in mechanical input ( $\Delta P_m$ ) will be zero when governor action is not represented. This will further simplify the above expression to

$$\Delta\omega_r = \frac{-\Delta P_L}{Ms + D}$$

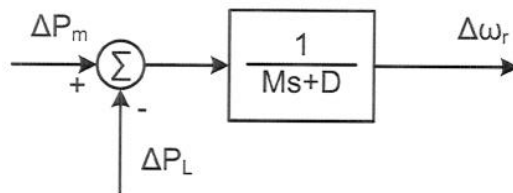

[5]

ii) with governor droop control having droop R.

[4]

Through governor droop control, mechanical power output  $\Delta P_m$  is influenced through governor dynamics and control. Let's now turn our attention to the influence of speed governing control on the frequency deviation due to change in load. We assume a generic turbine model  $G_t(s)$  as shown.

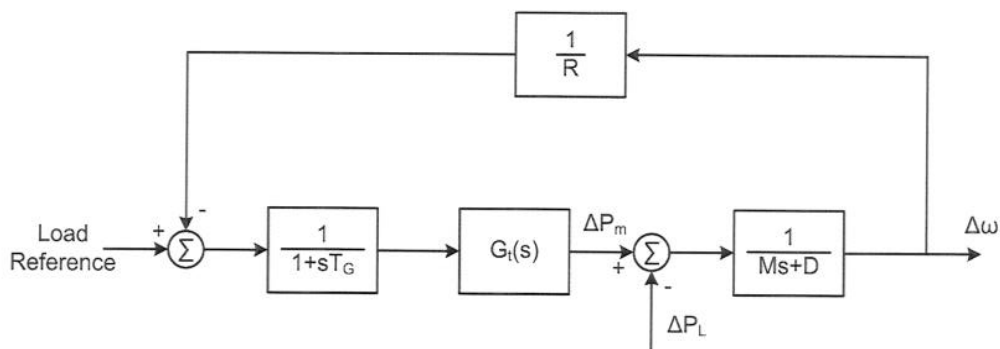

Fig: Block diagram of governor with droop for generator speed control

Let us assume that generic transfer function of turbine (steam as well as hydro) is expressed as  $G_t(s)$ . Assuming 100% efficiency the gain between the power input to the turbine to the power output will be unity. The transfer characteristic between  $\Delta P_L$  and  $\Delta\omega$  can be expressed as

$$\frac{\Delta\omega}{\Delta P_L} = -\frac{R(1+sT_G)}{G_t(s) + (Ms + D)R(1+sT_G)}$$

The steady state frequency deviation

$$\Delta\omega_{ss} = -\frac{\Delta P_L}{D + \frac{1}{R}}$$

It is interesting to note that the denominator is now dominated by the reciprocal of the droop (R). This will reduce the steady state speed deviation because of change in demand.

- c) A small 60 Hz system consists of 4 identical 500 MVA generating units feeding a total load of 1,020 MW. The H constant of each unit is 5.0 seconds on 500 MVA base. The load varies by 1.5% for 1% change in frequency. For a sudden drop in load by 20 MW answer the following
- Compute equivalent M, D and express load variation on 2000 MVA base

[6]

Answer:

H on 500 MVA is 5 seconds: Combined H for four units =  $4 \times 5 = 20$  seconds and on 2000 MVA it will be  $20 \times 500 / 2000 = 5$  seconds.  $M = 2H = 10$  seconds.

$D = 1.5\%$  change in load for 1% change in frequency: Since 20 MW load will be dropped, D has to be calculated on the remaining 1000 MW.

Change in load =  $1000 \times 1.5 / 100 = 15$  MW; Change in frequency is  $1 / 100 \times 60 = 0.6$  Hz. On 2000 MVA base this is  $15 / 2000 / (0.6) = 0.0125$  p.u/Hz or 0.0075 pu per 1% change in frequency.

- Find the frequency deviation in the steady state assuming no speed governing option

[2]

In the absence of speed governor the steady state frequency deviation is expressed as

$$\Delta f_{ss} = \frac{-\Delta P_L}{D}$$

On substituting the values  $\Delta f_{ss} = \frac{-(-20)}{.0125 \times 2000} = 0.8 \text{ Hz}$

[2]

- a) Describe the basic components and operating principle of any one of three classes of relay technology.

[5]

Answer:

The students are expected to describe and operating principle of one of electromechanical, solid state and numerical relay technology.

### Electromechanical relays

When the principle of electromechanical energy conversion is used for decision making, the relay is referred as an electromechanical relay. These relays represent the first generation of relays. Let us consider a simple example of an over current relay, which issues a trip signal if current in the apparatus is above a reference value. By proper geometrical placement of current carrying conductor in the magnetic field, Lorentz force  $F = Bil \sin \theta$  is produced in the coil (Fig 9.3)

This force is used to create the operating torque. If constant 'B' is used (for example by a permanent magnet), then the instantaneous torque produced is proportional to instantaneous value of the current. Since the instantaneous current is sinusoidal, the instantaneous torque is also sinusoidal which has a zero average value. Thus, no net deflection of operating coil is perceived.

On the other hand, if the B is also made proportional to the instantaneous value of the current, then the instantaneous torque will be proportional to square of the instantaneous current (non-negative quantity). The average torque will be proportional to square of the rms current. Movement of the relay contact caused by the operating torque may be restrained by a spring in the over current relay. If the spring has a spring constant 'k', then the deflection is proportional to the operating torque (in this case proportional to  $I_{rms}^2$ ).

When the deflection exceeds a preset value, the relay contacts closes and a trip decision is issued. Electromechanical relays are known for their ruggedness and immunity to Electromagnetic Interference (EMI).

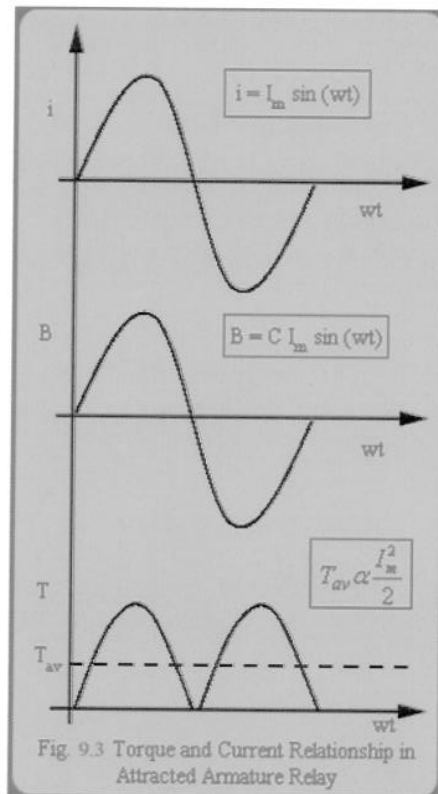

Fig. 9.3 Torque and Current Relationship in Attracted Armature Relay

### Solid state relays

With the advent of transistors, operational amplifiers etc, solid state relays were developed. They realise the functionality through various operations like comparators etc. They provide more flexibility and have less power consumption than their electromechanical counterpart. A major advantage with the solid state relays is their ability to provide self checking facility i.e. the relays can monitor their own health and raise a flag or alarm if its own component fails. Some of the advantages of solid state relays are low burden, improved dynamic performance characteristics, high seismic withstand capacity and reduced panel space.

Relay burden refers to the amount of volt amperes (VA) consumed by the relay. Higher is this value, more is the corresponding loading on the current and voltage sensors i.e. current transformers (CTs) and voltage transformers (VTs) which energizes these relays. Higher loading of the sensors leads to deterioration in their performance. A performance of CT or VT is gauged by the quality of the replication of the corresponding primary waveform signal. Higher burden leads to problem of CT saturation and inaccuracies in measurements. Thus it is desirable to keep CT/VT burdens as low as possible.

These relays have been now superseded by the microprocessor based relays or numerical relays.

### Numerical relays

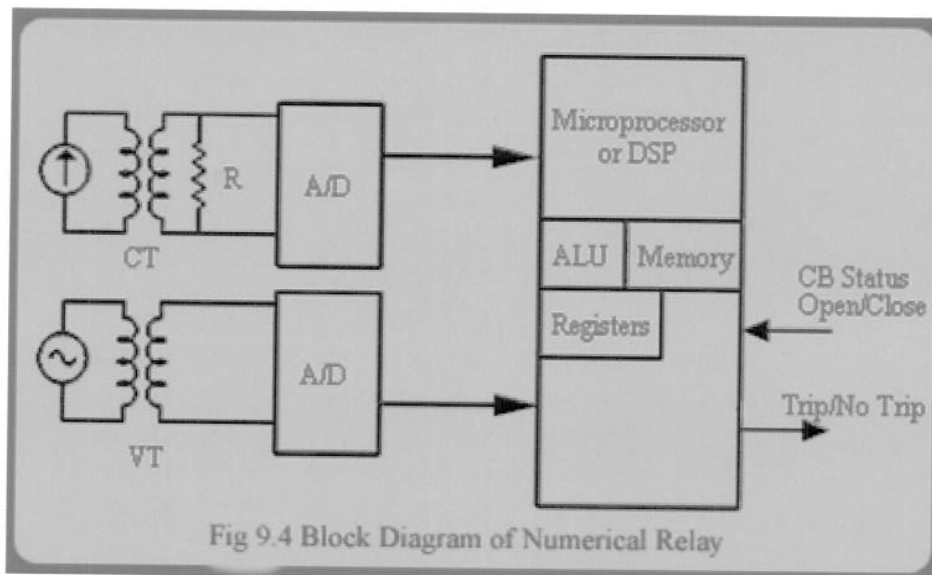

The block diagram of a numerical relay is shown in Fig 9.4. It involves analogue to digital (A/D) conversion of analogue voltage and currents obtained from secondary of CTs and VTs. These current and voltage samples are fed to the microprocessor or Digital Signal Processors (DSPs) where the protection algorithms or programs process the signals and decide whether a fault exists in the apparatus under consideration or not. In case, a fault is diagnosed, a trip decision is issued. Numerical relays provide maximum flexibility in defining relaying logic.

The hardware comprising of numerical relay can be made scalable i.e., the maximum number of v and i input signals can be scaled up easily. A generic hardware board can be developed to provide multiple functionalities. Changing the relaying functionality is achieved by simply changing the relaying program or

software. Also, various relaying functionalities can be multiplexed in a single relay. It has all the advantages of solid state relays like self checking etc. Enabled with communication facility, it can be treated as an Intelligent Electronic Device (IED) which can perform both control and protection functionality. Also, a relay that communicates can be made adaptive i.e. it can adjust to changing apparatus or system conditions. For example, a differential protection scheme can adapt to transformer tap changes. An overcurrent relay can adapt to different loading conditions. Numerical relays are both "the present and the future".

[5]

b) Distinguish between dependability and security of a relay

[4]

Answer

### **Dependability**

A relay is said to be dependable if it trips only when it is expected to trip. This happens either when the fault is in its primary jurisdiction or when it is called upon to provide the back-up protection. However, false tripping of relays or tripping for faults that is either not within its jurisdiction, or within its purview, compromises system operation. Power system may get unnecessarily stressed or else there can be loss of service. Dependability is the degree of certainty that the relay will operate correctly:

$$\% \text{ Dependability} = \frac{\text{Number of correct trips}}{\text{Number of desired trips}} \times 100$$

Dependability can be improved by increasing the sensitivity of the relaying system.

### **Security**

On the other hand, security is a property used to characterize false tripping of the relays. A relay is said to be secure if it does not trip when it is not expected to trip. It is the degree of certainty that the relay will not operate incorrectly:

$$\% \text{ Security} = \frac{\text{Number of correct trips}}{\text{Total number of trips}} \times 100$$

False trips do not just create nuisance. They can even affect system security. For example, tripping of a tie-line in a two area system can result in load-generation imbalance in each area which can be dangerous. Even when multiple paths for power flow are available, under peak load conditions, overloads or congestion in the system may result. Dependability and security are contrasting requirements. Typically, a relay engineer biases his setting towards dependability. This may cause some nuisance tripping, which can in the worst case, trigger partial or complete blackout! Security of the relaying system can be improved by improving selectivity of the relaying system

[4]

c) The performance of an over current relay was monitored for a period of three years. It was found that the relay operated 33 times, out of which 29 were correct trips. If the relay failed to issue trip decisions on 3 occasions, compute dependability, security and reliability of the relay as a percentage.

[6]



Answer:

Number of correct trips: 29

Number of desired trip  $29+3 = 32$ ;

Number of incorrect trip  $33-29 = 3$ ;

The definition of dependability, security and reliability in percentage are respectively as follows

$$\% \text{ Dependability} = \frac{\text{Number of correct trips}}{\text{Number of desired trips}} \times 100$$

$$\% \text{ Security} = \frac{\text{Number of correct trips}}{\text{Total number of trips}} \times 100$$

$$\% \text{ Reliability} = \frac{\text{Number of correct trips}}{\text{Number of desired trips} + \text{Number of incorrect trips}} \times 100$$

$$\% \text{ Dependability} = 29/32 * 100 = 90.36; \% \text{ Security} = 29/33 * 100 = 87.88;$$

$$\% \text{ Reliability} = 29/35 * 100 = 82.86.$$

[6]

d) How is selectivity achieved in transformer differential protection?

[5]

**Answer**

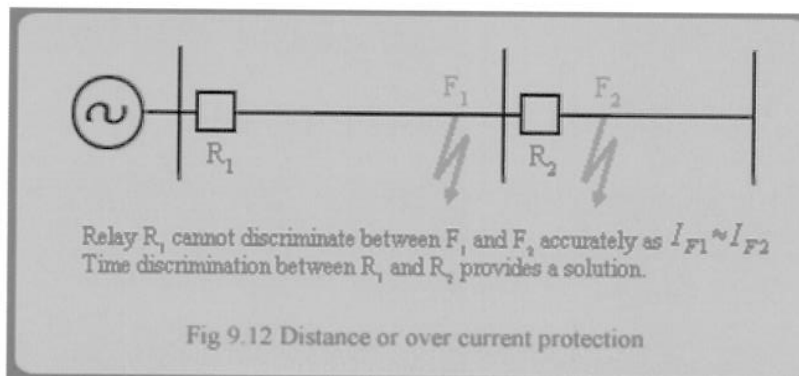

Like sensitivity, selectivity also implies an ability to discriminate. A relay should not confuse some peculiarities of an apparatus with a fault. For example, transformer when energized can draw up to 20 times rated current (inrush current) which can confuse, both

over current and transformer differential protection. Typically, inrush currents are characterized by large second harmonic content. This feature is used to inhibit relay operation during inrush, thereby, improving selectivity in transformer protection. Also, a relay should be smart enough, not just to identify a fault but also be able to decide whether fault is in its jurisdiction or not. For example, a relay for a feeder should be able to discriminate a fault on its own feeder from faults on adjacent feeders. This implies that it should detect first existence of fault in its vicinity in the system and then take a decision whether it is in its jurisdiction. Recall that directional over current relay was introduced to improve selectivity of over current relay.

This jurisdiction of a relay is also called as **zone of protection**. Typically, protection zones are classified into primary and backup zones. In detecting a fault and isolating the faulty element, the protective system must be very selective. Ideally, the protective system should zero-in on the faulty element and only isolate it, thus causing a minimum disruption to the system. Selectivity is usually provided by (1) using time discrimination and (2) applying differential protection principle. With over current and distance relays, such boundaries are not properly demarcated (see Fig 9.12). This is a very important consideration in operation of power systems.

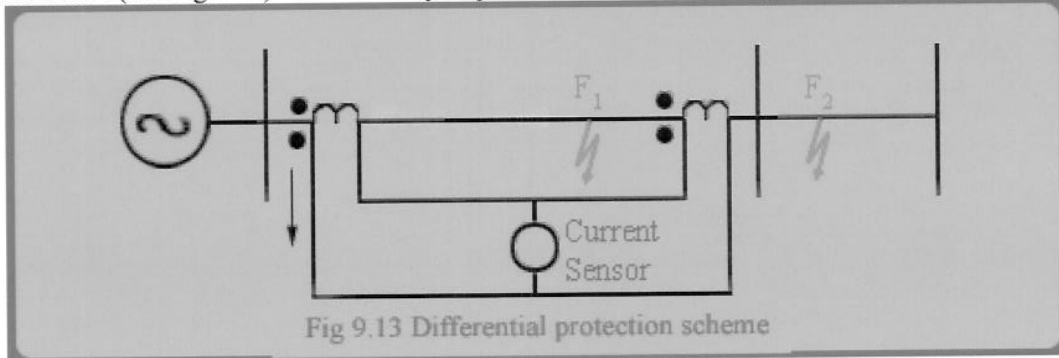

Fig 9.13 Differential protection scheme

However with a differential protection the CT location provides 'crisp' demarcation of zone of protection of CT (see Fig 9.13). The fault  $F_1$  is in the relay's zone of protection, but fault  $F_2$  is not in its jurisdiction. Because differential protection scheme does not require time discrimination to improve selectivity, they are essentially fast.

[5]

6

a) A 1200/5 C400 current transformer (CT) is connected to a relay with a burden of  $0.7 \Omega$ . The secondary resistance of the CT is  $0.61 \Omega$ . A secondary current of  $105 \text{ A}$  flows through the relay coil.

i) For this secondary current, is the CT still expected to behave in a linear manner? Justify your answer.

[3]

Answer

The rating of a relay defines the secondary voltage up to which linear operation is to be expected. In this case the relay is described as a C400 type relay, indicating it is a C class relay (low leakage reactance) in which saturation sets in if the secondary voltage exceeds  $400 \text{ V}$ .

In this case, we have been told that the relay is measuring a secondary current of  $105 \text{ A}$  (e.g. 21 time nominal). The burden on the secondary of the relay is  $0.61 + 0.7 = 1.31 \Omega$ . The secondary voltage that results from the particular burden is then:  $1.31 \times 105 = 138 \text{ V}$ . This is well below the "knee-point" in the operating curve for the CT, implying that the response of the device is still linear.

[3]

ii) The magnetising impedance (as referred to the secondary of the CT) is  $5 \text{ k} \Omega$ . Calculate the % ratio error

[4]

Answer

The ratio error summarises the comparative amount of current required to establish flux inside the CT as compared with the current being observed in the relay coil. In this case, the secondary current (measured current) is  $105 \text{ A}$ . For this current load and the given burden of  $1.31 \Omega$ , as calculated previously, the required secondary voltage of the relay is  $138 \text{ V}$ . Consequently, the magnetising or excitation current for the relay is  $138 / 5 \text{ k} \Omega = 27.6 \text{ mA}$ . The ratio error is determined by  $I_e / I_s = \text{excitation current} / \text{magnetising current} = 27.6 \text{ mA} / 105 \text{ A} = 0.026\%$  - very low

[4]

b) In what ways does a high ratio error affect the quality of CT's measurement?

[3]

Answer

A high ratio error indicates that the excitation current ( $I_e$ ) of the relay is significant (i.e.  $> 10\%$ ) of the secondary current ( $I_s$ ) that is following in the measurement winding of the relay. This has two impacts. First and foremost, as measured current (referred to the secondary winding) consists of the sum of the excitation current and the secondary current, e.g.  $I_p / N = I_e + I_s$ , a significant excitation current will result in an error in the magnitude of the current seen by the relay. Additionally, the current in the secondary winding is usually a predominantly resistive current. This contrasts with the excitation current which is predominantly inductive. Consequently, the need to supply a large, out-of-

phase current will lead to an appreciable divergence between the phase angle of the referred secondary current ( $I_p/N$ ) and the secondary current  $I_s$  which is the measured current. This error in phase angle could in turn affect the quality of the power flow measurements that can be derived from the system.

- c) What are the performance requirements of a protection grade CT? How do they differ from a measurement grade CT?

[4]

Answer

A protection grade relay must be designed to handle large fault current (i.e. up to 20 times rated currents) without the transformer going into saturation. In this way, the magnetising reactance of the transformer remains large from the normal pre-fault low flux condition up to the high current fault conditions during which there is a large amount of flux inside the transformer.

This is necessary so that it can accurately measure all fault currents, i.e. from low current faults, up to very severe faults. Accurate measurement of the fault current magnitudes over the full range of fault current is essential for coordination of the protective devices. For example, many relays are designed to trip faster for higher fault current (e.g. inverse time over-current relays). Without the ability to accurately distinguish between the severities of different faults such basic functionality would not be possible.

In contrast a measurement grade CT can be designed with a much lower VA rating. Generally it is designed to handle current only in the range of 5% to 125% of the rated voltage. To achieve this requires a very high magnetising reactance so that the device will operate correctly even at very low flux level (e.g. due to low measured currents). Operation of a measurement CT at currents well above the rated current though are likely to result in saturation of the transformer and large errors in the measured current (resulting from distortion in the waveshapes)

[4]

- d) Draw the equivalent circuit for a capacitively coupled voltage transformer (CCVT). What is the purpose of and required expression for the tuning inductor in this circuit?

[6]

Answer

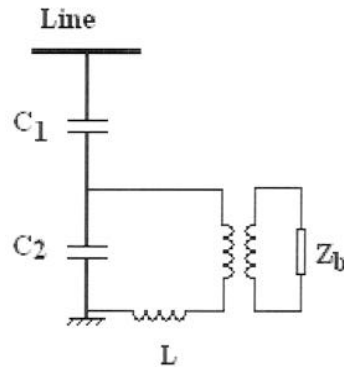

A capacitively coupled voltage transformer essentially uses a capacitive voltage divider to ensure that the voltage being measured is a scaled version of the line voltage to be observed. This offers economic voltage measurement scheme for protection and metering purpose. The presence of the capacitors however will affect the voltage that appears across the relay burden (and hence can be measured). Consider the Thevenin's equivalent impedance as determined at the point of the connection of the relay burden (i.e. the meter) While the Thevenin's equivalent voltage is the voltage across  $C_2$ , the Thevenin's impedance is  $-j/(\omega C_1 + \omega C_2)$ . When this is placed in the series with relay burden it will mean that the measured voltage is not correct. The purpose of the tuning inductor, shown as  $L$  on the primary side of the voltage transformer is to cancel out the apparent impedance of the capacitive divider. Consequently, it must have the value of  $\omega L = 1/(\omega C_1 + \omega C_2)$ .

In the diagram above it is drawn in the ground path of the primary side. This is where it is usually placed physically so that the voltage gradient across the inductor is smaller than if it were placed on the line-side of the capacitor, thereby reducing the physical requirements (in terms of insulation) on the device's construction.