

IMPERIAL COLLEGE LONDON

DEPARTMENT OF ELECTRICAL AND ELECTRONIC ENGINEERING
EXAMINATIONS 2007

MSc and EEE PART IV: MEng and ACGI

MODELLING AND CONTROL OF MULTI-BODY MECHANICAL SYSTEMS

Wednesday, 16 May 10:00 am

Time allowed: 3:00 hours

There are SIX questions on this paper.

Answer FOUR questions.

All questions carry equal marks.

This is an OPEN BOOK examination.

CORRECTED COPY

Any special instructions for invigilators and information for candidates are on page 1.

Examiners responsible First Marker(s) : A. Astolfi, S. Evangelou
Second Marker(s) : D.J.N. Limebeer, D.J.N. Limebeer

MODELLING AND CONTROL OF MULTIBODY MECHANICAL SYSTEMS

1. Consider a pendulum on a cart moving on a horizontal plane, as depicted in Figure 1.1. Let M be the mass of the cart, and assume that the pendulum can be modelled as a massless rod of length $L = 1$ with a mass M (equal to the mass of the cart) attached at its end. Assume the cart is subject to a force F , and q_1 and q_2 are as in the figure.

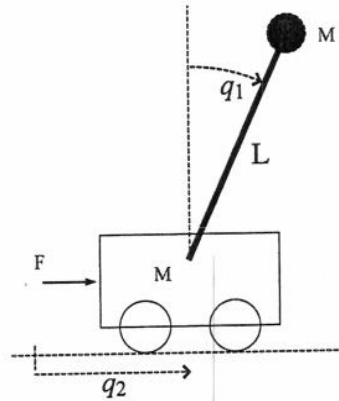

Figure 1.1 The pendulum on a cart.

- a) Compute the kinetic and potential energy of the system, and the internal Hamiltonian $H_0(q, p)$. [4 marks]
- b) Assuming that the coupling Hamiltonian $H_1(q)$ is

$$H_1(q) = -\sin q_1 + q_2,$$
 write the system in Hamiltonian form. [4 marks]
- c) Compute the natural output y of the system. [2 marks]
- d) Consider a damping injection control law, i.e. $F = -ky$.
 - i) Compute the time derivative of the internal Hamiltonian $H_0(q, p)$ along the trajectories of the closed-loop system. [4 marks]
 - ii) Consider the closed loop-system and assume that $y(t) = 0$ for all t . Compute all trajectories of the system that are consistent with this constraint. (Hint: assume that $y(t) = 0$ implies $p_2(t) = 0$.) [4 marks]
 - iii) Explain, from a physical point of view the result. [2 marks]

2. Consider a frictionless, rigid, two-limb pendulum, as depicted in Figure 2.1, with control inputs u_1 and u_2 . Let q_1 denote the angle of the lower limb with respect to the vertical axis and q_2 denote the angle between the upper limb and the direction of the lower limb. Suppose that both limbs are of unit length and that $q = [q_1 q_2]$.



Figure 2.1 The double pendulum.

Assume that the kinetic energy of the system is

$$T = \frac{1}{2} \dot{q}^T M(q) \dot{q},$$

where

$$M(q) = \begin{bmatrix} 3 + 2 \cos q_2 & 1 + \cos q_2 \\ 1 + \cos q_2 & 1 \end{bmatrix},$$

and the potential energy is

$$V(q) = g(2 \cos q_1 + \cos(q_1 + q_2)),$$

where g denotes the gravitational acceleration.

Finally, let the interaction Hamiltonians be

$$H_1(q) = q_1 \quad H_2(q) = q_2.$$

- Write the internal Hamiltonian $H_0(q, p)$ and the Hamiltonian equations of motion. [6 marks]
- Show that it is possible to asymptotically stabilize the up-up position (i.e. the equilibrium $q_1 = q_2 = 0$) of the pendulum using the first method of Lyapunov and only the control u_1 . [4 marks]
- Show that it is possible to asymptotically stabilize the down-down position (i.e. the equilibrium $q_1 = \pi, q_2 = 0$) of the pendulum using both controls and a damping injection controller. [4 marks]
- Show that it is possible to asymptotically stabilize the up-up position of the pendulum using the shaping function method and both controls. [6 marks]

3. As shown in Figure 3.1, a car of mass m is free to move on a horizontal plane under the influence of two (tyre) forces, one in the longitudinal and the other in the lateral direction with respect to the car, and a moment normal to the plane. The moment of inertia of the car about the axis normal to the plane and passing through the centre of mass, C , is I .

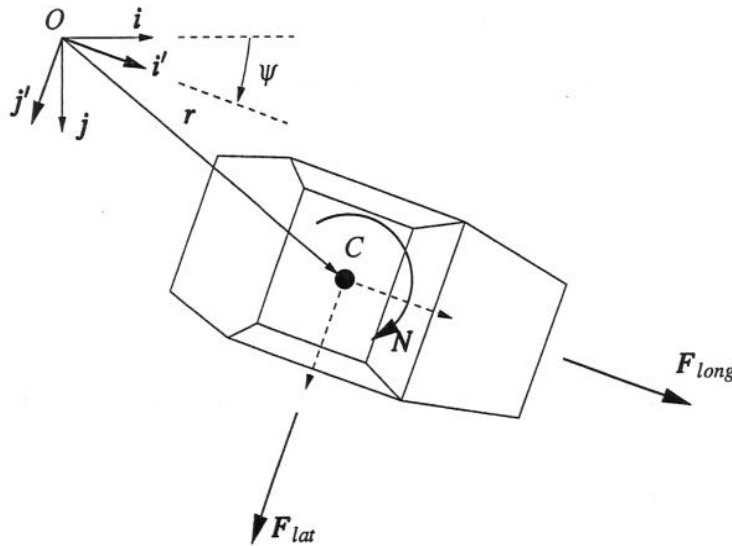

Figure 3.1 Simple car.

A moving Cartesian coordinate system with unit vectors i' and j' is used to analyse the motion of the car. This coordinate system has a fixed origin O but it rotates by an angle ψ so that it has the same orientation as the car fixed axes (shown with dashed lines on the car).

- The coordinates of the centre of mass, C , in the moving reference frame are (x', y') . Give the position vector, r , of C in the moving coordinate system. [2]
- Hence derive the velocity vector, \dot{r} , of C using the moving coordinate system. [4]
- Assume that the longitudinal speed of the car, v_x , is fixed.

- Show that

$$\dot{x}' - y'\dot{\psi} - y'\ddot{\psi} = 0.$$

[5]

- Express the acceleration vector, \ddot{r} , of the car centre of mass using the moving reference system, in terms of the longitudinal speed, v_x , the lateral speed, v_y , ψ . [5]
- Hence derive the equations of motion of the car using the moving reference system. [4]

4. A wheel rotates about its spin axis with a fixed angular velocity Ω_y . The spin axis is then rotated about the vertical direction with a fixed angular velocity Ω_v . The system is shown in Figure 4.1.

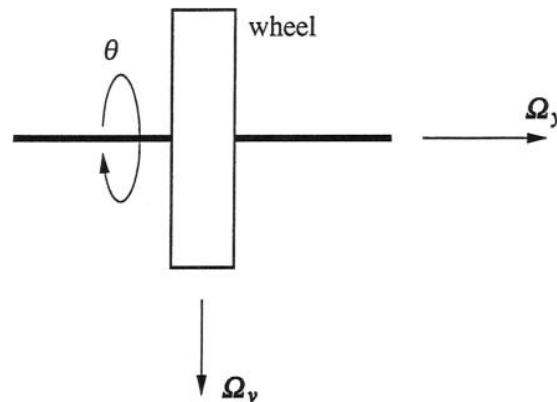

Figure 4.1 Wheel rotating about its spin axis and about the vertical direction.

The wheel is assumed to be cylindrical and to have uniform density. The spin moment of inertia of the wheel is I_{yy} . The moments of inertia about two mutually perpendicular axes passing through the centre of mass and which are both perpendicular to the spin axis are I_{xx} and I_{zz} .

- What is the relation between I_{xx} and I_{zz} ? Are the three axes associated with I_{xx} , I_{yy} , I_{zz} principal axes? Why? [5]
- θ is the angle of rotation about the spin axis direction. What is the relation between $\dot{\theta}$ and Ω_y ? [1]
- Write the angular momentum vector, \mathbf{H} , using a body fixed rectangular coordinate system. [5]
- Calculate the moment that is required to sustain the motion of the wheel.
 - Show that its magnitude is

$$I_{yy}\Omega_y\Omega_v$$

[6]

- What is the direction of this moment? [3]

5. A point mass is constrained to move on a massless hoop of radius a fixed in a vertical plane that is rotating about the vertical with constant angular speed ω .

- a) Treating the constraint of the hoop on the particle by the method of Lagrange multipliers, obtain the Lagrange equations of motion assuming the only external force arises from gravity. Use spherical coordinates in which the velocity vector of the particle is given by

$$\dot{\mathbf{r}} = \dot{r}\mathbf{e}_r + r\dot{\theta}\cos\phi\mathbf{e}_\theta + r\dot{\phi}\mathbf{e}_\phi.$$

[10]

- b) Write the forces of constraint exerted by the hoop on the point mass. [4]
- c) Show that if ω is greater than a critical value ω_0 , there can be a solution in which the particle remains stationary on the hoop at a point other than at the bottom, but that if $\omega < \omega_0$, the only stationary point for the particle is at the bottom of the hoop. What is the value of ω_0 ? [6]

6. a) Consider a helicopter blade of mass m that is attached onto a rotor of negligible mass that rotates with a fixed angular speed ω about its centre axis. The blade is allowed to flap relative to the rotor as shown in Figure 6.1.

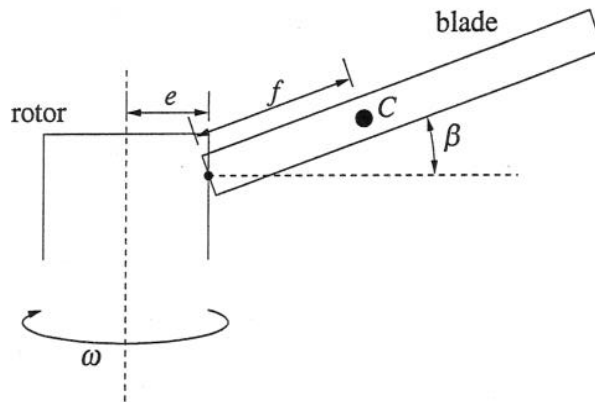

Figure 6.1 A helicopter rotor with one blade.

The distance of the point of attachment of the blade onto the rotor from the centre axis of the rotor is e , and the distance along the blade from the blade attachment point to the centre of mass of the blade, C , is f . The three principal moments of inertia of the blade about the centre of mass are I_{xx} , I_{yy} and I_{zz} . I_{xx} is with respect to an axis along the blade, I_{yy} with respect to an axis normal to the plane of the diagram at the instant shown and I_{zz} with respect to an axis which is perpendicular to both the previous axes. The effect of gravity is neglected.

- i) Write an expression for the kinetic energy of the system. [4]
 ii) Show that the flapping equation of motion is

$$(I_{yy} + mf^2)\ddot{\beta} + (I_{zz} - I_{xx})\omega^2 \sin \beta \cos \beta + mf(e + f \cos \beta)\omega^2 \sin \beta = 0. \quad [6]$$

- b) Derive Euler's equation of motion from the Lagrange equation of motion for the generalised coordinate ϕ (the angle of the last rotation in the yaw-pitch-roll Euler angle rotation sequence). [10]

Modelling and control of multibody mechanical systems

Model answers 2007

Question 1

- a) To compute the kinetic energy of the system note that the positions p_M and p_m of the center of mass of the cart and of the end of the pendulum on a cartesian plane with x -axis parallel to the q_2 axis and the z -axis directed upward are given by (recall that $L = 1$)

$$p_M = (q_2, 0) \quad p_m = (q_2 + \sin q_1, \cos q_1).$$

As a result the kinetic energy is given by (recall that $M = m$)

$$\begin{aligned} K &= \frac{1}{2}m\|\dot{p}_M\|^2 + \frac{1}{2}m\|\dot{p}_m\|^2 \\ &= \frac{1}{2}m\dot{q}_2^2 + \frac{1}{2}m\left((\dot{q}_2 + \dot{q}_1 \cos q_1)^2 + \dot{q}_1^2 \sin^2 q_1\right) \end{aligned}$$

hence

$$K = \frac{1}{2}\dot{q}'\mathcal{M}\dot{q} = \frac{1}{2}m \begin{bmatrix} \dot{q}_1 & \dot{q}_2 \end{bmatrix} \begin{bmatrix} 1 & \cos q_1 \\ \cos q_1 & 2 \end{bmatrix} \begin{bmatrix} \dot{q}_1 \\ \dot{q}_2 \end{bmatrix}.$$

The potential energy is only *due* to the pendulum and it is given by (recall that $L = 1$)

$$V = mg \cos q_1.$$

The internal Hamiltonian is

$$H_0(q, p) = \frac{1}{2} \begin{bmatrix} p_1 & p_2 \end{bmatrix} \mathcal{M}^{-1} \begin{bmatrix} p_1 \\ p_2 \end{bmatrix} + mg \cos q_1.$$

- b) The Hamiltonian equations of motion are

$$\dot{q} = \mathcal{M}^{-1}p$$

and

$$\dot{p} = -\frac{1}{2} \frac{\partial(p'\mathcal{M}^{-1}p)}{\partial q} + \begin{bmatrix} mg \sin q_1 \\ 0 \end{bmatrix} + \begin{bmatrix} -\cos q_1 \\ 1 \end{bmatrix} u.$$

- c) The natural output is

$$y = \frac{\partial H_0}{\partial p} \left(\frac{\partial H_1}{\partial q} \right)' = \frac{1}{m} \frac{p_2(\cos^2 q_1 + 1) - 3p_1 \cos q_1}{2 - \cos^2 q_1}.$$

- d) The time derivative of the internal Hamiltonian with the given damping injection controller is $\dot{H}_0 = -ky^2$. Note that $y = 0$ implies $u = 0$ and

$$p_2 = 3 \frac{\cos q_1}{\cos^2 q_1 + 1} p_1.$$

Replacing this in the the Hamiltonian equations of motion yields

$$\dot{q}_1 = \frac{1}{m} \frac{1}{\cos^2 q_1 + 1} p_1 \quad \dot{q}_2 = \frac{1}{m} \frac{\cos q_1}{\cos^2 q_1 + 1} p_1$$

and

$$\dot{p}_1 = \sin q_1 gm - \frac{\cos q_1 \sin q_1}{(1 + \cos^2 q_1)^2} p_1^2 \quad \dot{p}_2 = 0.$$

As suggested we assume that $p_2 = 0$, hence we have two possibilities. Either $p_1 = 0$ or $\cos q_1 = 0$.

If $p_1 = 0$ we have $\dot{q}_1 = 0$ and $\dot{q}_2 = 0$. Moreover $p_1 = 0$ implies $\dot{p}_1 = 0$, which implies that $\sin q_1 = 0$. Hence $q_1 = 0$ or $q_1 = \pi$. From a physical point of view the trajectory obtained above describes the cart with the pendulum aligned along the vertical (upward or downward) and with the cart stationary at some location that we cannot determine.

If $\cos q_1 = 0$ then $q_1 = \pm\pi/2$ which implies $\dot{q}_1 = 0$. As a result, $p_1 = 0$, and this implies $\dot{p}_1 = 0$. However, in this case $\dot{p}_1 = gm \sin q_1 \neq 0$, which is a contradiction. This means that $y = 0$ does not imply $\cos q_1 = 0$.

Question 2

a) The Hamiltonian is

$$H(q, p, u) = \frac{1}{2}p'M(q)^{-1}p + V(q) - q_1u_1 - q_2u_2,$$

and the Hamiltonian equations of motion are

$$\dot{q} = M(q)^{-1}p$$

and

$$\dot{p} = -\frac{\partial(p'M^{-1}p)}{\partial q} - g \begin{bmatrix} 2 \sin q_1 + \sin(q_1 + q_2) \\ \sin(q_1 + q_2) \end{bmatrix} + \begin{bmatrix} u_1 \\ u_2 \end{bmatrix}.$$

b) The system linearized around the up-up position is described by the equations

$$\dot{\delta}_x = \begin{bmatrix} 0 & 0 & 1 & -2 \\ 0 & 0 & -2 & 5 \\ -3g & -g & 0 & 0 \\ -g & -g & 0 & 0 \end{bmatrix} \delta_x + \begin{bmatrix} 0 \\ 0 \\ 1 \\ 0 \end{bmatrix} \delta_u.$$

The controllability matrix is

$$C = \begin{bmatrix} B & AB & A^2B & A^3B \end{bmatrix} = \begin{bmatrix} 0 & 1 & 0 & -3g \\ 0 & -2 & 0 & 7g \\ 1 & 0 & -g & 0 \\ 0 & 0 & g & 0 \end{bmatrix}$$

and this has rank four. Hence the considered equilibrium is locally stabilizable using a linear feedback control law.

c) The down-down position is a minimum of the potential energy. The damping injection control law is described by

$$u = -kM(q)^{-1}p.$$

The time derivative of the internal Hamiltonian along the closed-loop system is

$$\dot{H}_0 = -kp'M(q)^{-2}p = -k\dot{q}'\dot{q}.$$

Hence the equilibrium is stable and p goes to zero. In addition $p = 0$ implies $\dot{q} = 0$ hence all trajectories approach the equilibrium, which is therefore asymptotically stable.

d) To asymptotically stabilize the up-up position using the shaping function method we have to show that it is possible to modify the potential energy, rendering the point $(q_1, q_2) = (0, 0)$ a local minimum, by means of a P-type control law. (Note that the up-up position is a maximum of the potential energy.) Setting $u = -Kq$ yields a shaped potential energy \tilde{V} described by

$$\tilde{V} = V + \frac{1}{2}q'Kq.$$

Selecting K symmetric, positive definite and sufficiently large (for example $K = kI$, with $k \gg 1$) results in a shaped potential energy with a minimum at the desired equilibrium. Therefore, the application of a damping injection control law is such that the up-up equilibrium is asymptotically stable.

Question 3

- a) The position vector is simply

$$\mathbf{r} = x'\mathbf{i}' + y'\mathbf{j}'.$$

- b) The derivatives of the unit vectors \mathbf{i}' , \mathbf{j}' with respect to time are given by

$$\frac{d\mathbf{i}'}{dt} = \dot{\psi}\mathbf{j}',$$

and

$$\frac{d\mathbf{j}'}{dt} = -\dot{\psi}\mathbf{i}'.$$

Therefore by differentiation of the position vector, the velocity vector is

$$\dot{\mathbf{r}} = (\dot{x}' - y'\dot{\psi})\mathbf{i}' + (x'\dot{\psi} + \dot{y}')\mathbf{j}'.$$

- c) i) The forward speed of the car is the coefficient $\dot{x}' - y'\dot{\psi}$, of the unit vector \mathbf{i}' in the velocity vector expression, i.e.

$$v_x = \dot{x}' - y'\dot{\psi}.$$

v_x is constant if $\dot{v}_x = 0$. Therefore, by differentiation of the above expression we get

$$\ddot{x}' - \dot{y}'\dot{\psi} - y'\ddot{\psi} = 0.$$

- ii) The velocity vector can be written in terms of v_x and v_y as

$$\dot{\mathbf{r}} = v_x\mathbf{i}' + v_y\mathbf{j}'.$$

By differentiation of the above, the acceleration vector is

$$\ddot{\mathbf{r}} = -v_y\dot{\psi}\mathbf{i}' + (\dot{v}_y + v_x\dot{\psi})\mathbf{j}'.$$

- iii) The equation describing the motion of the centre of mass in the longitudinal direction is

$$F_{long} = -mv_y\dot{\psi},$$

and in the lateral direction is

$$F_{lat} = m(\dot{v}_y + v_x\dot{\psi}).$$

Finally the equation describing the rotational motion of the car about the centre of mass is

$$N = I\ddot{\psi}.$$

Notice that the longitudinal equation gives the force of constraint needed to keep the forward speed fixed.

Question 4

a) $I_{zz} = I_{xx}$ due to symmetry. The three axes are principal axes. The spin axis is in the direction of the axis of symmetry and the wheel is a solid of revolution.

b) $\dot{\theta} = \Omega_y$.

c) The angular momentum vector is

$$\mathbf{H} = -I_{xx}\Omega_v \sin \theta \mathbf{i}' + I_{yy}\Omega_y \mathbf{j}' + I_{xx}\Omega_v \cos \theta \mathbf{k}'$$

d) The equation describing motion about the centre of mass is

$$\frac{d'\mathbf{H}}{dt} + \boldsymbol{\Omega} \times \mathbf{H} = \mathbf{N}. \quad (1)$$

The first term on the left is the derivative of the angular momentum vector as seen from the body fixed axes. It amounts to

$$\frac{d'\mathbf{H}}{dt} = -I_{xx}\Omega_v \cos \theta \dot{\theta} \mathbf{i}' - I_{xx}\Omega_v \sin \theta \dot{\theta} \mathbf{k}'.$$

But $\dot{\theta} = \Omega_y$, and therefore

$$\frac{d'\mathbf{H}}{dt} = -I_{xx}\Omega_v\Omega_y(\cos \theta \mathbf{i}' + \sin \theta \mathbf{k}').$$

The second term of equation 1 arises due to the rotation of the body fixed axes and it amounts to

$$\begin{aligned} \boldsymbol{\Omega} \times \mathbf{H} &= \\ &= (-\Omega_v \sin \theta \mathbf{i}' + \Omega_y \mathbf{j}' + \Omega_v \cos \theta \mathbf{k}') \times (-I_{xx}\Omega_v \sin \theta \mathbf{i}' + I_{yy}\Omega_y \mathbf{j}' + I_{xx}\Omega_v \cos \theta \mathbf{k}') = \\ &= -\Omega_y\Omega_v \cos \theta (I_{yy} - I_{xx}) \mathbf{i}' + \Omega_y\Omega_v \sin \theta (I_{xx} - I_{yy}) \mathbf{k}'. \end{aligned}$$

We add the two terms and we get

$$\frac{d'\mathbf{H}}{dt} + \boldsymbol{\Omega} \times \mathbf{H} = -I_{yy}\Omega_y\Omega_v(\cos \theta \mathbf{i}' + \sin \theta \mathbf{k}').$$

Therefore, the moment needed to sustain the motion is

$$\mathbf{N} = -I_{yy}\Omega_y\Omega_v(\cos \theta \mathbf{i}' + \sin \theta \mathbf{k}').$$

i) The magnitude of this moment is

$$|\mathbf{N}| = I_{yy}\Omega_y\Omega_v,$$

ii) and its direction is always perpendicular to both the spin axis and the vertical direction.

Question 5

a) The kinetic energy of the system is

$$T = \frac{1}{2}m(\dot{r}^2 + r^2\dot{\theta}^2 \cos^2 \phi + r^2\dot{\phi}^2),$$

and the potential energy is

$$V = mgr \sin \phi.$$

(The centre of the hoop is taken as the zero potential energy point).

The system has two constraints

$$f_1 = r - a = 0,$$

and

$$f_2 = \theta - \omega t = 0.$$

The Lagrangian function is given by

$$L = T - V = \frac{1}{2}m(\dot{r}^2 + r^2\dot{\theta}^2 \cos^2 \phi + r^2\dot{\phi}^2) - mgr \sin \phi.$$

For the first generalised coordinate, r , we have

$$\frac{d}{dt} \left(\frac{\partial L}{\partial \dot{r}} \right) - \frac{\partial L}{\partial r} + \lambda_1 \frac{\partial f_1}{\partial r} = 0.$$

But

$$-\lambda_1 \frac{\partial f}{\partial r} = F_r$$

where F_r is the force of constraint in the radial direction. Therefore

$$\frac{d}{dt} (m\dot{r}) - (mr\dot{\theta}^2 \cos^2 \phi + mr\dot{\phi}^2 - mg \sin \phi) = F_r,$$

or

$$m\ddot{r} - mr\dot{\theta}^2 \cos^2 \phi - mr\dot{\phi}^2 + mg \sin \phi = F_r.$$

From the constraint equations we have $\dot{r} = \ddot{r} = 0$ and $\dot{\theta} = \omega$, $\ddot{\theta} = 0$. Therefore the above equation gives the radial force of constraint as

$$F_r = -ma\omega^2 \cos^2 \phi - ma\dot{\phi}^2 + mg \sin \phi.$$

The Lagrangian equation for the second generalised coordinate, θ , gives

$$\frac{d}{dt} \left(\frac{\partial L}{\partial \dot{\theta}} \right) - \frac{\partial L}{\partial \theta} + \lambda_2 \frac{\partial f_2}{\partial \theta} = 0.$$

But

$$-\lambda_2 \frac{\partial f_2}{\partial \theta} = N_\theta,$$

where N_θ is the moment of constraint about the vertical direction. The force of constraint in the e_θ direction is

$$F_\theta = \frac{N_\theta}{r \cos \phi}.$$

Therefore

$$\frac{d}{dt} (mr^2\dot{\theta} \cos^2 \phi) = F_{\theta} r \cos \phi,$$

or

$$2mrr\dot{\theta} \cos^2 \phi + mr^2\ddot{\theta} \cos^2 \phi - 2mr^2\dot{\theta}\dot{\phi} \cos \phi \sin \phi = F_{\theta} r \cos \phi.$$

By making use of the constraint equations we get the second force of constraint as

$$F_{\theta} = -2ma\omega\dot{\phi} \sin \phi.$$

The Lagrangian equation of the third generalised coordinate, ϕ , will give us the equation of motion:

$$\frac{d}{dt} \left(\frac{\partial L}{\partial \dot{\phi}} \right) - \frac{\partial L}{\partial \phi} = 0,$$

or

$$\frac{d}{dt} (mr^2\dot{\phi}) - (-mr^2\dot{\theta}^2 \cos \phi \sin \phi - mgr \cos \phi) = 0,$$

or

$$2mrr\dot{\phi} + mr^2\ddot{\phi} + mr^2\dot{\theta}^2 \cos \phi \sin \phi + mgr \cos \phi = 0.$$

By making use of the constraint equations the equation of motion reduces to

$$a\ddot{\phi} + a\omega^2 \cos \phi \sin \phi + g \cos \phi = 0.$$

b) The forces of constraint F_r and F_{θ} are given above.

c) The particle remains stationary when $\ddot{\phi} = 0$. The last equation above shows that this happens when

$$a\omega^2 \cos \phi \sin \phi + g \cos \phi = 0,$$

or

$$\cos \phi (a\omega^2 \sin \phi + g) = 0.$$

When $\omega = 0$ the only way the above expression becomes zero is when $\cos \phi = 0$ or when $\phi = -90^\circ$ which is the lowest point of the hoop. As ω increases from zero the term in the brackets above is possible to become zero for some value of ϕ when

$$a\omega^2 > g,$$

or

$$\omega > \sqrt{\frac{g}{a}}.$$

Therefore

$$\omega_0 = \sqrt{\frac{g}{a}}.$$

Question 6

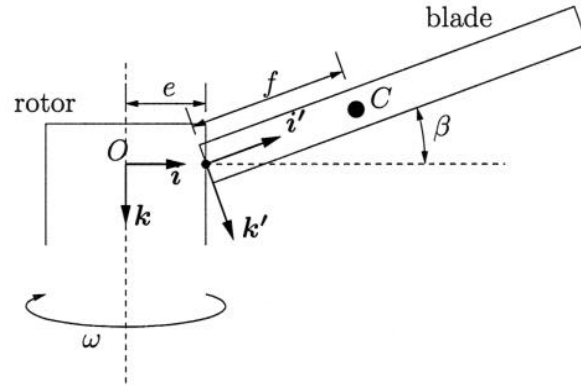

Figure 1: A helicopter rotor with one blade.

- a) i) The position vector of the centre of mass of the blade is

$$\mathbf{r} = e\mathbf{i} + f\mathbf{i}'.$$

The angular velocity of the rotor fixed coordinate system is

$$\boldsymbol{\Omega} = \omega\mathbf{k},$$

and the angular velocity of the blade fixed coordinate system is

$$\boldsymbol{\Omega}' = \omega\mathbf{k} + \dot{\beta}\mathbf{j}'.$$

The velocity vector of the centre of mass is given by

$$\dot{\mathbf{r}} = e\boldsymbol{\Omega} \times \mathbf{i} + f\boldsymbol{\Omega}' \times \mathbf{i}' = e\omega\mathbf{k} \times \mathbf{i} + f(\omega\mathbf{k} + \dot{\beta}\mathbf{j}') \times \mathbf{i}' = e\omega\mathbf{j}' + f\omega \cos \beta \mathbf{j}' - f\dot{\beta}\mathbf{k}',$$

since \mathbf{j}' is parallel to \mathbf{j} . Therefore the kinetic energy is given by

$$T = \frac{1}{2}m \left((e + f \cos \beta)^2 \omega^2 + f^2 \dot{\beta}^2 \right) + \frac{1}{2}I_{xx}\omega^2 \sin^2 \beta + \frac{1}{2}I_{yy}\dot{\beta}^2 + \frac{1}{2}I_{zz}\omega^2 \cos^2 \beta.$$

- ii) The Lagrangian function of the system is $L = T$ since there are no external forces. The Lagrangian equation corresponding to the flapping freedom is

$$\frac{d}{dt} \left(\frac{\partial L}{\partial \dot{\beta}} \right) - \frac{\partial L}{\partial \beta} = 0,$$

or

$$\frac{d}{dt} \left(I_{yy}\dot{\beta} + mf^2\dot{\beta} \right) - (I_{xx}\omega^2 \sin \beta \cos \beta - I_{zz}\omega^2 \sin \beta \cos \beta - m(e + f \cos \beta)f\omega^2 \sin \beta) = 0,$$

or

$$(I_{yy} + mf^2)\ddot{\beta} + (I_{zz} - I_{xx})\omega^2 \sin \beta \cos \beta + mf(e + f \cos \beta)\omega^2 \sin \beta = 0.$$

- b) The angular velocities along the body fixed axes are given in terms of the Euler angles as follows:

$$\begin{aligned}\Omega_{x'} &= \dot{\phi} - \dot{\psi} \sin \theta \\ \Omega_{y'} &= \dot{\theta} \cos \phi + \dot{\psi} \cos \theta \sin \phi \\ \Omega_{z'} &= -\dot{\theta} \sin \phi + \dot{\psi} \cos \theta \cos \phi.\end{aligned}$$

(Taken from the handout.) The kinetic energy of the rigid body is therefore

$$T = \frac{1}{2}I_{xx}(\dot{\phi} - \dot{\psi} \sin \theta)^2 + \frac{1}{2}I_{yy}(\dot{\theta} \cos \phi + \dot{\psi} \cos \theta \sin \phi)^2 + \frac{1}{2}I_{zz}(-\dot{\theta} \sin \phi + \dot{\psi} \cos \theta \cos \phi)^2.$$

The Lagrangian is $L = T$ and the Lagrangian equation of motion corresponding to the generalised coordinate ϕ is

$$\frac{d}{dt} \left(\frac{\partial L}{\partial \dot{\phi}} \right) - \frac{\partial L}{\partial \phi} = N_{x'},$$

where $N_{x'}$ is the external torque along the x' axis. Evaluating the components of the Lagrangian equation gives

$$\frac{\partial L}{\partial \dot{\phi}} = I_{xx}(\dot{\phi} - \dot{\psi} \sin \theta) = I_{xx}\Omega_{x'},$$

and

$$\frac{d}{dt} (I_{xx}(\dot{\phi} - \dot{\psi} \sin \theta)) = I_{xx}(\ddot{\phi} - \ddot{\psi} \sin \theta - \dot{\psi} \dot{\theta} \cos \theta) = I_{xx}\dot{\Omega}_{x'}.$$

The next term in the Lagrangian equation is

$$\begin{aligned}\frac{\partial L}{\partial \phi} &= I_{yy}(\dot{\theta} \cos \phi + \dot{\psi} \cos \theta \sin \phi)(-\dot{\theta} \sin \phi + \dot{\psi} \cos \theta \cos \phi) + \\ &+ I_{zz}(-\dot{\theta} \sin \phi + \dot{\psi} \cos \theta \cos \phi)(-\dot{\theta} \cos \phi - \dot{\psi} \cos \theta \sin \phi),\end{aligned}$$

or

$$\frac{\partial L}{\partial \phi} = I_{yy}\Omega_{y'}\Omega_{z'} - I_{zz}\Omega_{z'}\Omega_{y'}.$$

Putting everything together we get

$$I_{xx}\dot{\Omega}_{x'} - \Omega_{y'}\Omega_{z'}(I_{yy} - I_{zz}) = N_{x'},$$

which is the Euler equation that we are after.

