

IMPERIAL COLLEGE LONDON

DEPARTMENT OF ELECTRICAL AND ELECTRONIC ENGINEERING
EXAMINATIONS 2004

MSc and EEE/ISE PART IV: MEng and ACGI

ADVANCED DATA COMMUNICATIONS

Monday, 26 April 10:00 am

Time allowed: 3:00 hours

There are FOUR questions on this paper.

Answer THREE questions.

All questions carry equal marks



Corrected Copy

Any special instructions for invigilators and information for candidates are on page 1.

Examiners responsible First Marker(s) : M.K. Gurcan
Second Marker(s) : A.G. Constantinides

Special Instructions for Invigilators: None

Information for candidates:

Useful equations

Suppose $g(t)$ and $G(f)$ are Fourier transform pairs such that

$$g(t) \Leftrightarrow G(f)$$

where

$$G(f) = \int_{-\infty}^{\infty} g(t) \exp(-j2\pi f t) dt \text{ and}$$

$$g(t) = \int_{-\infty}^{\infty} G(f) \exp(j2\pi f t) df .$$

Then the following Fourier transform relationships might be useful

$$g(t) = \text{rect}\left(\frac{t}{T}\right) \Leftrightarrow G(f) = T \text{sinc}(f T)$$

$$g(t) = \delta(t) \Leftrightarrow G(f) = 1$$

$$x(t) = \text{sinc}\left(\frac{t}{T}\right) \frac{\cos\left(\frac{\pi \alpha t}{T}\right)}{1 - \frac{4\alpha^2 t^2}{T^2}} \Leftrightarrow X_{RC}(f) = \begin{cases} T, & 0 \leq |f| \leq \frac{1-\alpha}{2T} \\ \frac{T}{2} \left\{ 1 + \cos\left(\frac{\pi T}{\alpha} \left(|f| - \frac{1-\alpha}{2T}\right)\right) \right\}, & \frac{1-\alpha}{2T} < |f| \leq \frac{1+\alpha}{2T} \\ 0, & |f| > \frac{1+\alpha}{2T} \end{cases}$$

1. a) A three-level PAM system is used to transmit the output of a memoryless ternary source whose rate is 2000 symbols/sec. The signal constellation is shown in the following figure where A is the signal amplitude, T is the symbol period and $\psi(t)$ is the orthonormal function. Determine the input to the detector, the optimum threshold that minimizes the average probability of error, and the average probability of error if the noise is Additive-White-Gaussian-noise. [5]

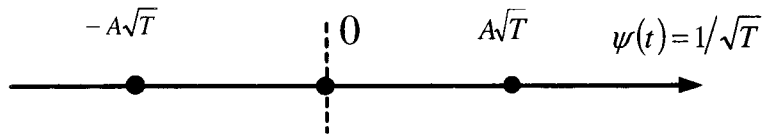

- b) A speech signal is sampled at a rate of 8 kHz, logarithmically compressed and encoded into a PCM format using 8 bits/sample. The PCM data is transmitted through an AWGN baseband channel via M -level PAM. Determine the bandwidth required for transmission when (a) $M = 4$, (b) $M = 8$, and (c) $M = 16$. [5]
- c) Consider the 8-point QAM constellation shown in the following diagram.

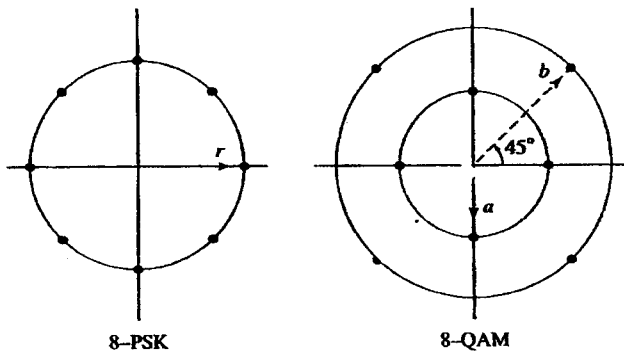

- i) The nearest neighbour signal points in the 8-QAM signal constellation are separated in distance by A units. Determine the radii a and b of the inner and outer circles. [3]
- ii) The adjacent signal points in the 8-PSK are separated by a distance of A units. Determine the radius r of the circle. [4]
- iii) Determine the average transmitter powers for the two signal constellations and compare the two powers. What is the relative power advantage of one constellation over the other? (Assume that all signal points are equally probable). [3]

2. a) A binary PAM signal is generated by exciting a raised cosine roll-off filter with a 50% roll-off factor and is then DSB-SC amplitude modulated on a sinusoidal carrier as illustrated in the following figure. The bit rate is 2400 bits/sec.

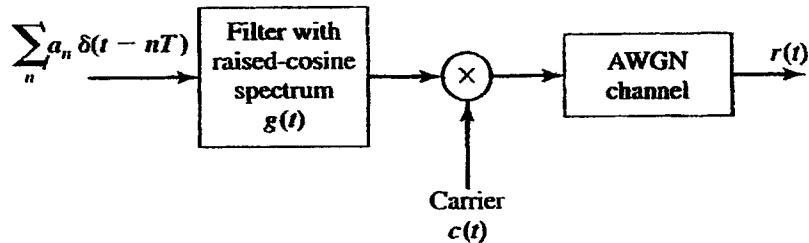

- i) Determine the spectrum of the modulated binary PAM signal and sketch it. [4]
- ii) Draw the block diagram illustrating the optimum demodulator/detector for the received signal which is equal to the transmitted signal plus additive, white Gaussian noise. [5]
- b) $M=4$ PAM modulation is used for transmitting at a bit rate of 9600 bits/sec on a channel having frequency response

$$C(f) = \frac{1}{1 + j\frac{f}{f_c}}, \quad f_c = 2400\text{Hz}$$

for $|f| \leq 2400$ Hz and $C(f) = 0$, otherwise. The additive noise is zero-mean, white Gaussian with power-spectral density $N_0/2$ W/Hz. Determine the (magnitude) frequency response characteristics of the optimum transmitting and receiving filters. [11]

3. a) Consider the convolution encoder shown in the following diagram.

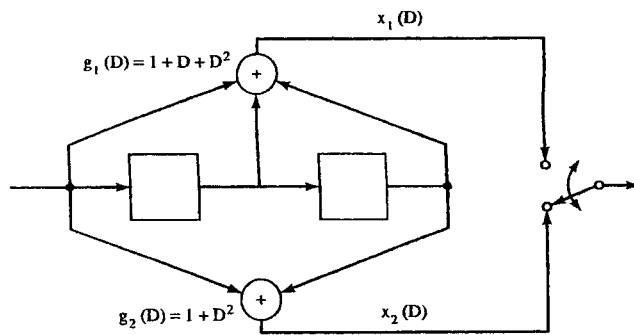

The encoder is initialised with the data sequence 0 0 0. Assume that the channel is additive white Gaussian noise and at the output of the receiver matched filter the sequence 10 10 10 11 11 10 01 11 is observed. Using the Viterbi algorithm, identify the surviving paths over 8 symbol periods and produce the decoded data sequence.

[11]

- b) Describe the set partitioning principle that can be used to improve M -ary modulation system Bit Error Rate performance.

[9]

4. a) Describe how the guard time and cyclic extensions are used in OFDM multi-carrier modulation systems to deal with multi-path delay spreads [8]
- b) Describe how the turbo decoder operates recursively to calculate the log-likelihood ratios. [12]

*Confidential***MODEL ANSWERS and MARKING SCHEME**

First Examiner: Gurcan, M.K.

Paper Code : E4.04, SC6, ISE4.9

Second Examiner: Constantinides, A.G.

Question 1 Page 1 out of 14

Question labels in left margin

Marks allocations in right margin

1.a

The three symbols A , 0 and $-A$ are used with equal probability. Hence, the optimal detector uses two thresholds, which are $\frac{A}{2}$ and $-\frac{A}{2}$, and it bases its decisions on the criterion

$$\begin{aligned} A : & \quad r > \frac{A}{2} \\ 0 : & \quad -\frac{A}{2} < r < \frac{A}{2} \\ -A : & \quad r < -\frac{A}{2} \end{aligned}$$

If the variance of the AWG noise is σ_n^2 , then the average probability of error is

$$\begin{aligned} P(e) &= \frac{1}{3} \int_{-\infty}^{\frac{A}{2}} \frac{1}{\sqrt{2\pi\sigma_n^2}} e^{-\frac{(r-A)^2}{2\sigma_n^2}} dr + \frac{1}{3} \left(1 - \int_{-\frac{A}{2}}^{\frac{A}{2}} \frac{1}{\sqrt{2\pi\sigma_n^2}} e^{-\frac{r^2}{2\sigma_n^2}} dr \right) \\ &\quad + \frac{1}{3} \int_{-\frac{A}{2}}^{\infty} \frac{1}{\sqrt{2\pi\sigma_n^2}} e^{-\frac{(r+A)^2}{2\sigma_n^2}} dr \\ &= \frac{1}{3} Q \left[\frac{A}{2\sigma_n} \right] + \frac{1}{3} 2Q \left[\frac{A}{2\sigma_n} \right] + \frac{1}{3} Q \left[\frac{A}{2\sigma_n} \right] \\ &= \frac{4}{3} Q \left[\frac{A}{2\sigma_n} \right] \end{aligned}$$

Confidential

MODEL ANSWERS and MARKING SCHEME

First Examiner: Gurcan, M.K.

Paper Code : E4.04, SC6, ISE4.9

Second Examiner: Constantinides, A.G.

Question 1 Page 2 out of 14

Question labels in left margin

Marks allocations in right margin

1.b

The bandwidth required for transmission of an M -ary PAM signal is

$$W = \frac{R_b}{2 \log_2 M} \text{ Hz}$$

Since,

$$R_b = 8 \times 10^3 \frac{\text{samples}}{\text{sec}} \times 8 \frac{\text{bits}}{\text{sample}} = 64 \times 10^3 \frac{\text{bits}}{\text{sec}}$$

we obtain

$$W = \begin{cases} 16 \text{ KHz} & M = 4 \\ 10.667 \text{ KHz} & M = 8 \\ 8 \text{ KHz} & M = 16 \end{cases}$$

Confidential

MODEL ANSWERS and MARKING SCHEME

First Examiner: Gurcan, M.K.

Paper Code : E4.04, SC6, ISE4.9

Second Examiner: Constantinides, A.G.

Question 1 Page 3 out of 14

Question labels in left margin

Marks allocations in right margin

I.C 1) Consider the QAM constellation of Fig. 1. Using the Pythagorean theorem we can find the radius of the inner circle as

$$a^2 + a^2 = A^2 \implies a = \frac{1}{\sqrt{2}}A$$

The radius of the outer circle can be found using the cosine rule. Since b is the third side of a triangle with a and A the two other sides and angle between them equal to $\theta = 75^\circ$, we obtain

$$b^2 = a^2 + A^2 - 2aA \cos 75^\circ \implies b = \frac{1 + \sqrt{3}}{2}A$$

2) If we denote by r the radius of the circle, then using the cosine theorem we obtain

$$A^2 = r^2 + r^2 - 2r \cos 45^\circ \implies r = \frac{A}{\sqrt{2 - \sqrt{2}}}$$

3) The average transmitted power of the PSK constellation is

$$P_{\text{PSK}} = 8 \times \frac{1}{8} \times \left(\frac{A}{\sqrt{2 - \sqrt{2}}} \right)^2 \implies P_{\text{PSK}} = \frac{A^2}{2 - \sqrt{2}}$$

whereas the average transmitted power of the QAM constellation

$$P_{\text{QAM}} = \frac{1}{8} \left(4 \frac{A^2}{2} + 4 \frac{(1 + \sqrt{3})^2}{4} A^2 \right) \implies P_{\text{QAM}} = \left[\frac{2 + (1 + \sqrt{3})^2}{8} \right] A^2$$

The relative power advantage of the PSK constellation over the QAM constellation is

$$\text{gain} = \frac{P_{\text{PSK}}}{P_{\text{QAM}}} = \frac{8}{(2 + (1 + \sqrt{3})^2)(2 - \sqrt{2})}$$

Confidential

MODEL ANSWERS and MARKING SCHEME

First Examiner: Gurcan, M.K.

Paper Code : E4.04, SC6, ISE4.9

Second Examiner: Constantinides, A.G.

Question 2 Page 4 out of 14

Question labels in left margin

Marks allocations in right margin

2.a

a) The spectrum of the baseband signal is

$$S_b(f) = \frac{1}{T} S_c(f) |X_m(f)|^2 + \frac{1}{T} |X_m(f)|^2$$

where $T = \frac{1}{f_{\text{mod}}}$ and

$$X_m(f) = \begin{cases} T & 0 \leq |f| \leq \frac{1}{4T} \\ \frac{T}{2}(1 + \cos(2\pi T(|f| - \frac{1}{4T}))) & \frac{1}{4T} \leq |f| \leq \frac{3}{4T} \\ 0 & \text{otherwise} \end{cases}$$

If the carrier signal has the form $c(t) = A \cos(2\pi f_c t)$, then the spectrum of the DSB-SC modulated signal, $S_s(f)$, is

$$S_s(f) = \frac{A}{2} [S_b(f - f_c) + S_b(f + f_c)]$$

A sketch of $S_s(f)$ is shown in the next figure.

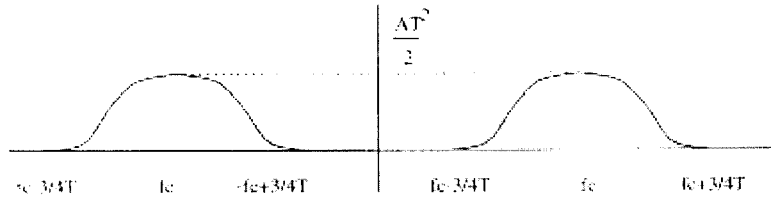

b) Assuming bandpass coherent demodulation (using a matched filter), the received signal $r(t)$ is first passed through a linear filter with impulse response

$$g_R(t) = A r_c(T - t) \cos(2\pi f_c(T - t))$$

The output of the matched filter is sampled at $t = T$ and the samples are passed to the detector. The detector is a simple threshold device that decides if a binary 1 or 0 was transmitted depending on the sign of the input samples. The following figure shows a block diagram of the optimum bandpass coherent demodulator.

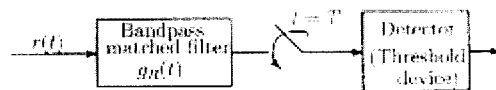

Confidential

MODEL ANSWERS and MARKING SCHEME

First Examiner: Gurcan, M.K.

Paper Code : E4.04, SC6, ISE4.9

Second Examiner: Constantinides, A.G.

Question 2 Page 5 out of 14

Question labels in left margin

Marks allocations in right margin

2.b A 4-PAM modulation can accommodate $k = 2$ bits per transmitted symbol. Thus, the symbol interval duration is

$$T = \frac{k}{9600} = \frac{1}{4800} \text{ sec}$$

Since, the channel's bandwidth is $W = 2400 = \frac{1}{2T}$, in order to achieve the maximum rate of transmission, $R_{\max} = \frac{1}{2T}$, the spectrum of the signal pulse should be

$$X(f) = T\Pi\left(\frac{f}{2W}\right)$$

Then, the magnitude frequency response of the optimum transmitting and receiving filter is

$$|G_T(f)| = |G_R(f)| = \left[1 + \left(\frac{f}{2400}\right)^2\right]^{\frac{1}{4}} \Pi\left(\frac{f}{2W}\right) = \begin{cases} \left[1 + \left(\frac{f}{2400}\right)^2\right]^{\frac{1}{4}}, & |f| < 2400 \\ 0 & \text{otherwise} \end{cases}$$

Confidential

MODEL ANSWERS and MARKING SCHEME

First Examiner: Gurcan, M.K.

Paper Code : E4.04, SC6, ISE4.9

Second Examiner: Constantinides, A.G.

Question 3 Page 6 out of 14

Question labels in left margin

Marks allocations in right margin

3.
a

At the end of first time slot

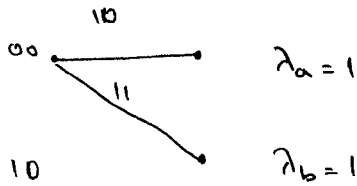

At the end of second time slot

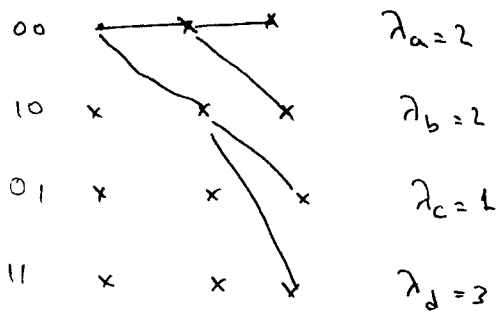

At the end of third time slot

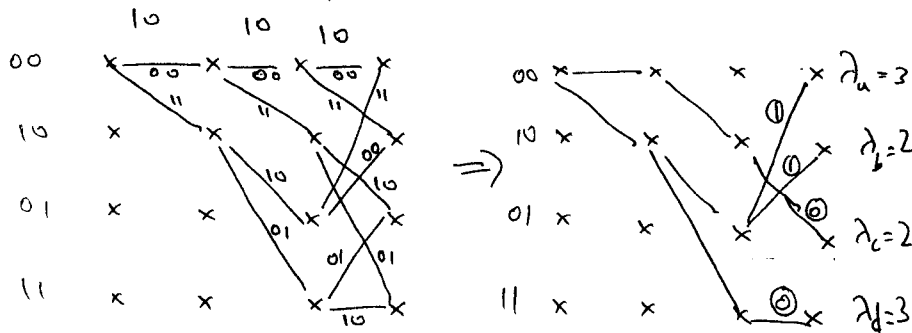

Confidential

MODEL ANSWERS and MARKING SCHEME

First Examiner: Gurcan, M.K.

Paper Code : E4.04, SC6, ISE4.9

Second Examiner: Constantinides, A.G.

Question 3 Page 7 out of 14

Question labels in left margin

Marks allocations in right margin

3.a
cont

At the end of 4th time slot

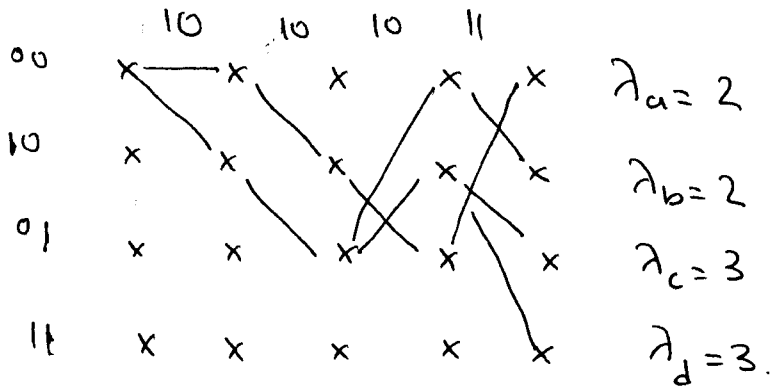
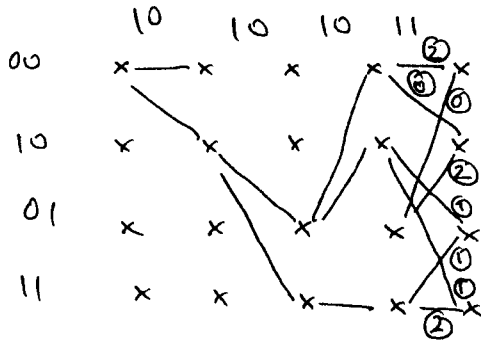

At the end of 5th time slot

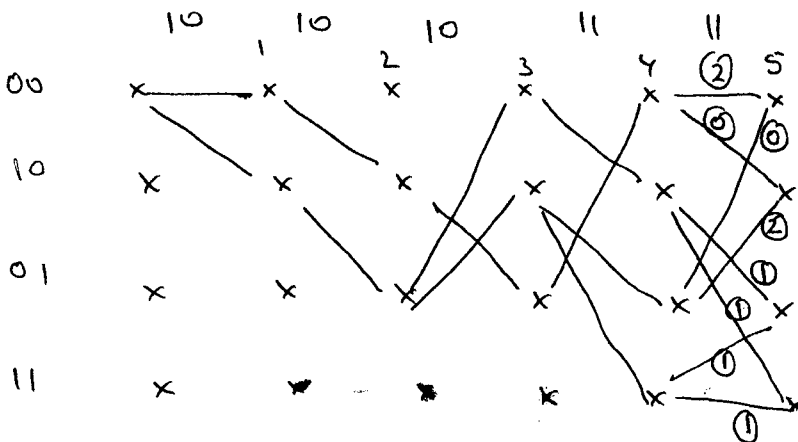

Confidential

MODEL ANSWERS and MARKING SCHEME

First Examiner: Gurcan, M.K.

Paper Code : E4.04, SC6, ISE4.9

Second Examiner: Constantinides, A.G.

Question 3 Page 8 out of 14

Question labels in left margin

Marks allocations in right margin

3.a
cont

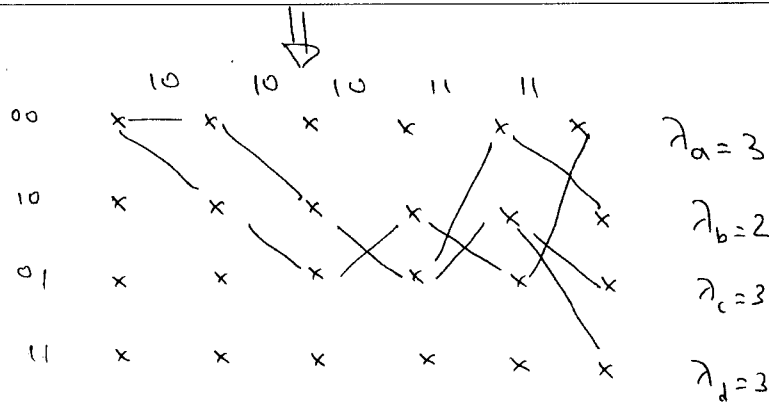

At the end of 6 time slot

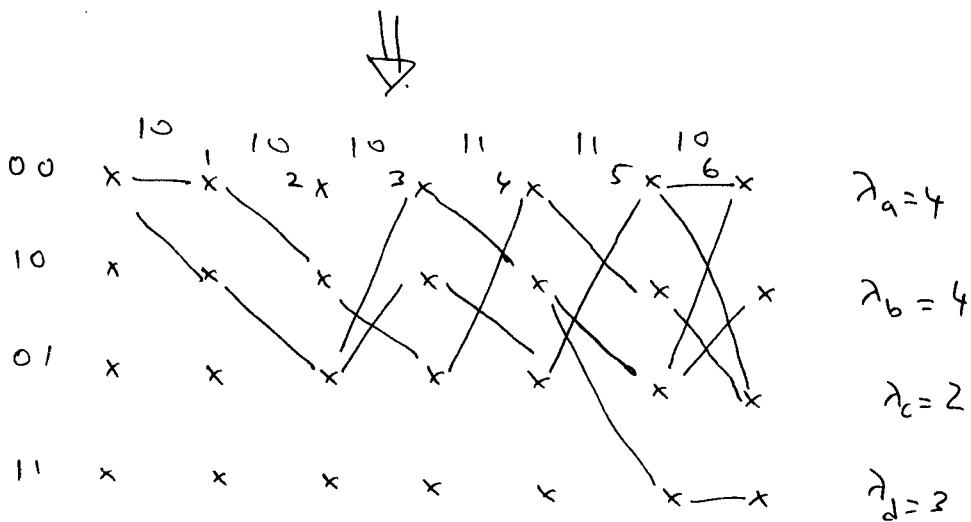
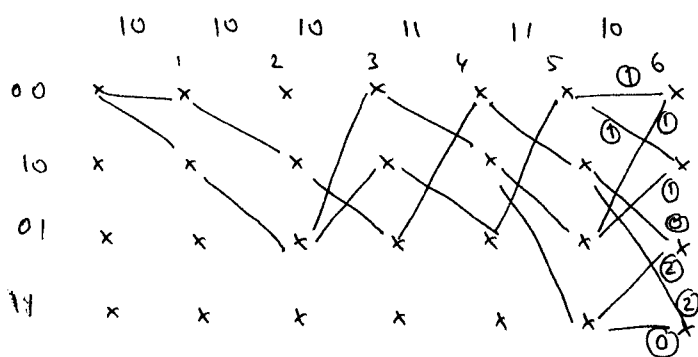

Confidential

MODEL ANSWERS and MARKING SCHEME

First Examiner: Gurcan, M.K.

Paper Code : E4.04, SC6, ISE4.9

Second Examiner: Constantinides, A.G.

Question 3 Page 9 out of 14

Question labels in left margin

Marks allocations in right margin

3.a
cont

At the end of 7th time slot we have

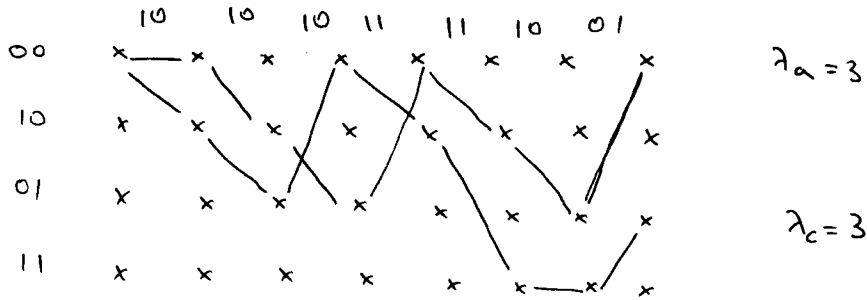

At the end of 8th time slot

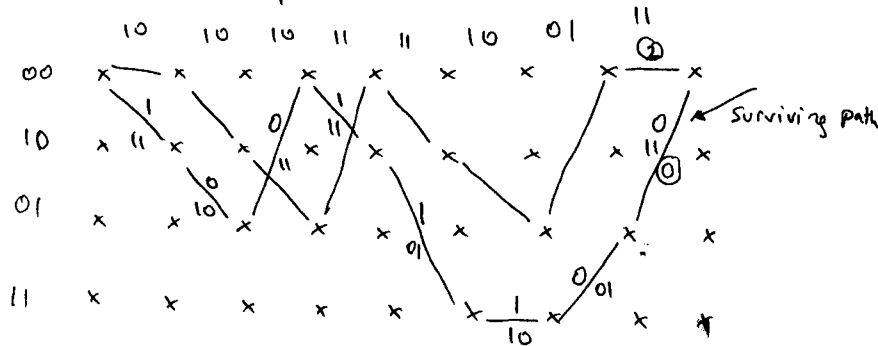

Decoded data sequence.

1 0 0 1 1 1 0 0

Corresponding encoded sequence

11 10 11 11 01 10 01 11

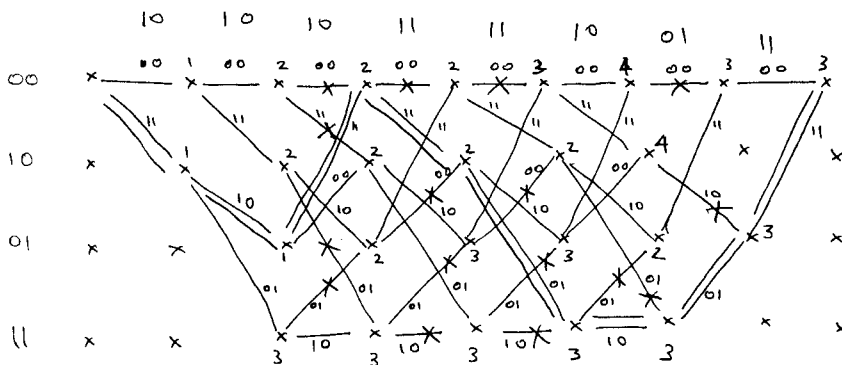

received sequence

11 10 11 11 01 10 01 11

Received data

1 0 0 1 1 1 0 0

Confidential

MODEL ANSWERS and MARKING SCHEME

First Examiner: Gurcan, M.K.

Paper Code : E4.04, SC6, ISE4.9

Second Examiner: Constantinides, A.G.

Question 3 Page 10 out of 14

Question labels in left margin

Marks allocations in right margin

3.b

The approach used to design this type of trellis codes involves partitioning an M -ary constellation of interest successively into 2, 4, 8, . . . subsets with size $M/2, M/4, M/8, \dots$, and having progressively larger increasing minimum Euclidean distance between their respective signal points. Such a design approach by *set partitioning* represents the “key idea” in the construction of efficient coded modulation techniques for band-limited channels.

In Figure we illustrate the partitioning procedure by considering a circular constellation that corresponds to 8-PSK. The figure depicts the constellation itself and the 2 and 4 subsets resulting from two levels of partitioning. These subsets share the common

$$d_0 = 2 \sin\left(\frac{\pi}{8}\right) = \sqrt{2 - \sqrt{2}}$$

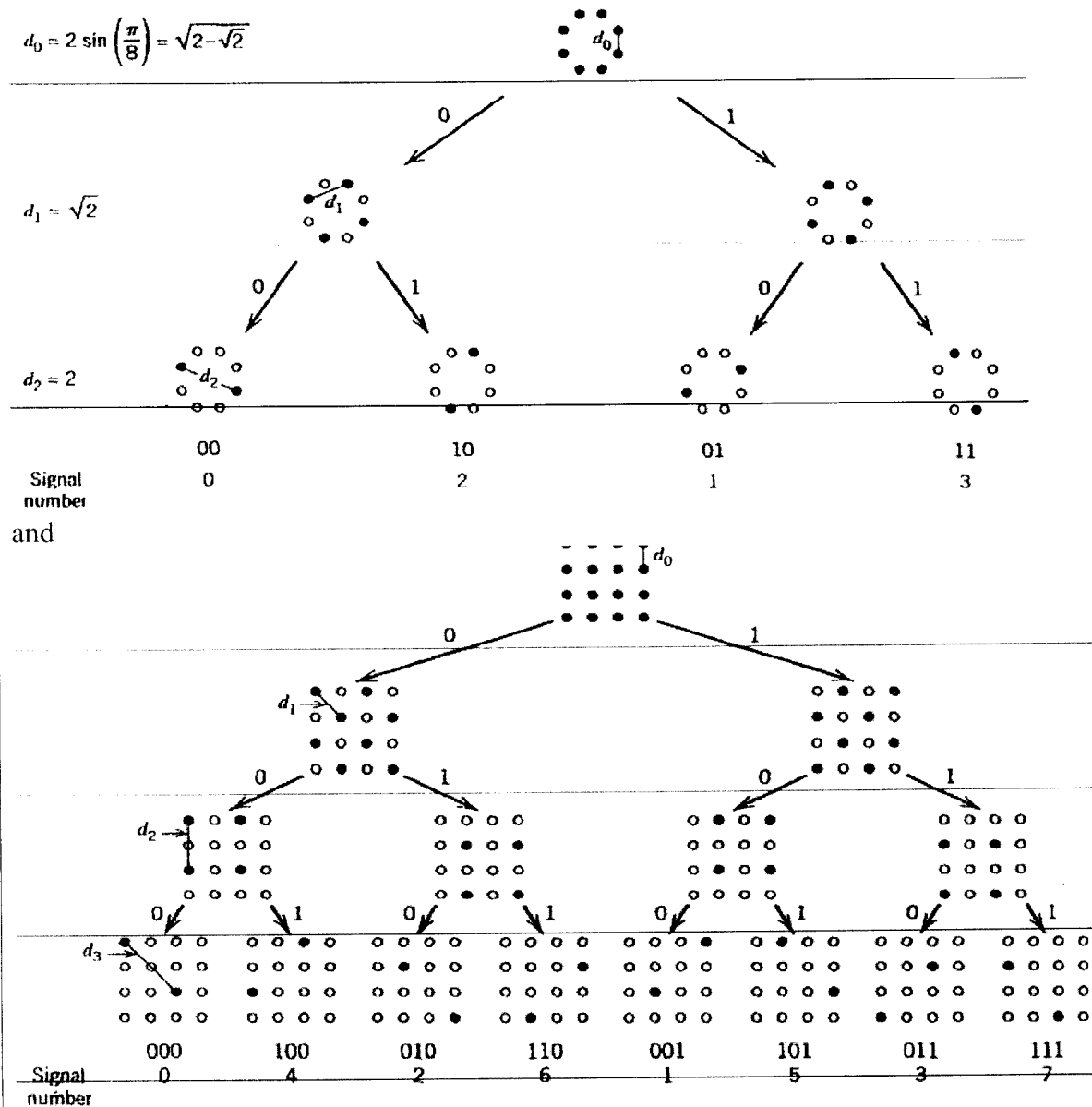

Confidential

MODEL ANSWERS and MARKING SCHEME

First Examiner: Gurcan, M.K.

Paper Code : E4.04, SC6, ISE4.9

Second Examiner: Constantinides, A.G.

Question 3 Page 11 out of 14

Question labels in left margin

Marks allocations in right margin

3-b
continued

property that the minimum Euclidean distances between their individual points follow an increasing pattern: $d_0 < d_1 < d_2$.

Based on the subsets resulting from successive partitioning of a two-dimensional constellation, we may devise relatively simple and yet highly effective coding schemes. Specifically, to send n bits/symbol with *quadrature modulation* (i.e., one that has in-phase and quadrature components), we start with a two-dimensional constellation of 2^{n+1} signal points appropriate for the modulation format of interest; a circular grid is used for M -ary PSK, and a rectangular one for M -ary QAM. In any event, the constellation is partitioned into 4 or 8 subsets. One or two incoming bits per symbol enter a rate-1/2 or rate-2/3 binary convolutional encoder, respectively; the resulting two or three coded bits per symbol determine the selection of a particular subset. The remaining uncoded data bits determine which particular point from the selected subset is to be signaled. This class of trellis code is known as *Ungerboeck codes*.

Since the modulator has memory, we may use the Viterbi algorithm to perform maximum likelihood sequence estimation at the receiver. Each branch in the trellis of the Ungerboeck code corresponds to a subset rather than an individual signal point. The first step in the detection is to determine the signal point within each subset that is closest to the received signal point in the Euclidean sense. The signal point so determined and its metric (i.e., the squared Euclidean distance between it and the received point) may be used thereafter for the branch in question, and the Viterbi algorithm may then proceed in the usual manner.

Confidential

MODEL ANSWERS and MARKING SCHEME

First Examiner: Gurcan, M.K.

Paper Code : E4.04, SC6, ISE4.9

Second Examiner: Constantinides, A.G.

Question 4 Page 12 out of 14

Question labels in left margin

Marks allocations in right margin

4.a

One of the most important reasons to do OFDM is the efficient way it deals with multipath delay spread. By dividing the input datastream in N_s subcarriers, the symbol duration is made N_s times smaller, which also reduces the relative multipath delay spread, relative to the symbol time, by the same factor. To eliminate intersymbol interference almost completely, a guard time is introduced for each OFDM symbol. The guard time is chosen larger than the expected delay spread, such that multipath components from one symbol cannot interfere with the next symbol. The guard time could consist of no signal at all. In that case, however, the problem of intercarrier interference (ICI) would arise. ICI is crosstalk between different subcarriers, which means they are no longer orthogonal. This effect is illustrated in Figure . In this example, a subcarrier 1 and a delayed subcarrier 2 are shown. When an OFDM receiver tries to demodulate the first subcarrier, it will encounter some interference from the second subcarrier, because within the FFT interval, there is no integer number of cycles difference between subcarrier 1 and 2. At the same time, there will be crosstalk from the first to the second subcarrier for the same reason.

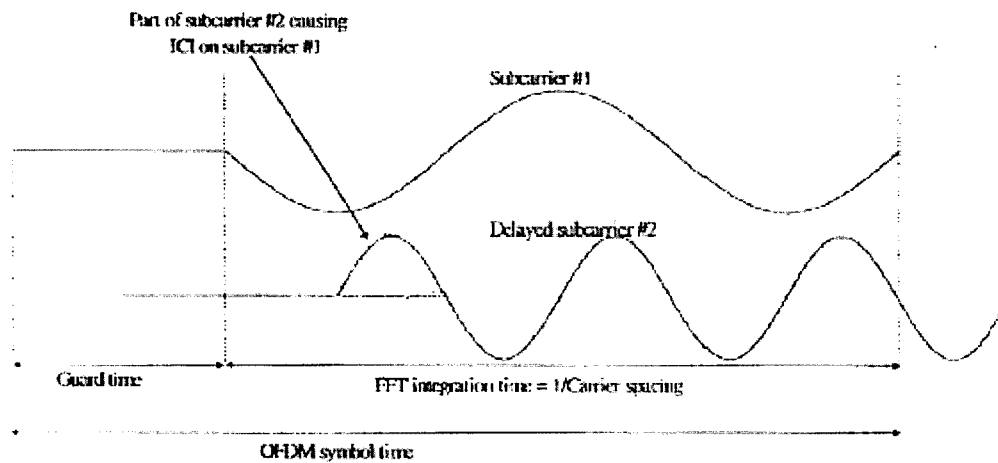

To eliminate ICI, the OFDM symbol is cyclically extended in the guard time, as shown in Figure . This ensures that delayed replicas of the OFDM symbol always have an integer number of cycles within the FFT interval, as long as the delay is smaller than the guard time. As a result, multipath signals with delays smaller than the guard time cannot cause ICI.

Confidential

MODEL ANSWERS and MARKING SCHEME

First Examiner: Gurcan, M.K.

Paper Code : E4.04, SC6, ISE4.9

Second Examiner: Constantinides, A.G.

Question 4 Page 13 out of 14

Question labels in left margin

Marks allocations in right margin

4.a

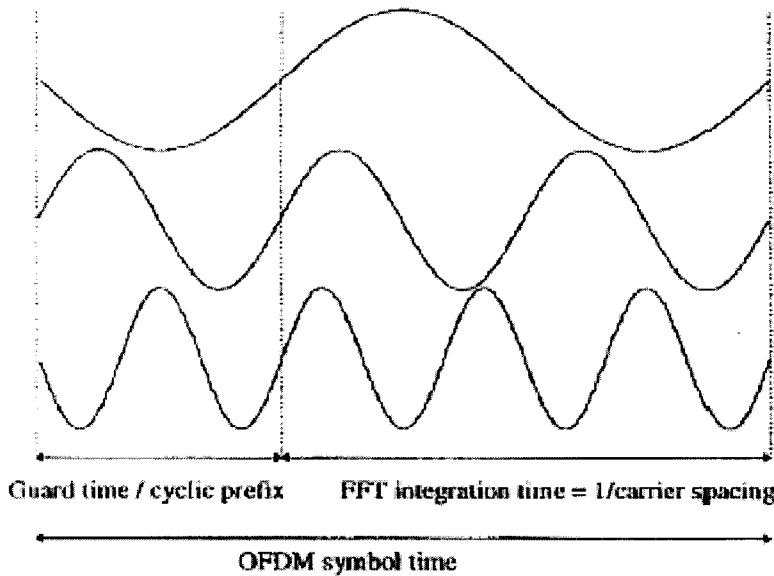

As an example of how multipath affects OFDM, Figure shows received signals for a two-ray channel, where the dotted curve is a delayed replica of the solid curve. Three separate subcarriers are shown during three symbol intervals. In reality, an OFDM receiver only sees the sum of all these signals, but showing the separate components makes it more clear what the effect of multipath is. From the figure, we can see that the OFDM subcarriers are BPSK modulated, which means that there can be 180-degree phase jumps at the symbol boundaries. For the dotted curve, these phase jumps occur at a certain delay after the first path. In this particular example, this multipath delay is smaller than the guard time, which means there are no phase transitions during the FFT interval. Hence, an OFDM receiver "sees" the sum of pure sine waves with some phase offsets. This summation does not destroy the orthogonality between the subcarriers, it only introduces a different phase shift for each subcarrier.

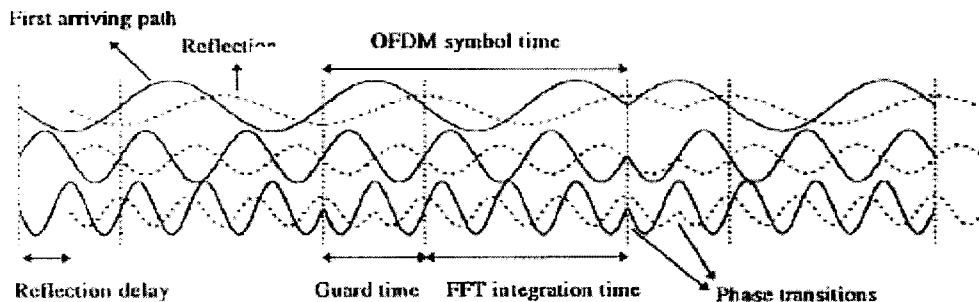

Confidential

MODEL ANSWERS and MARKING SCHEME

First Examiner: Gurcan, M.K.

Paper Code : E4.04, SC6, ISE4.9

Second Examiner: Constantinides, A.G.

Question 4 Page 14 out of 14

Question labels in left margin

Marks allocations in right margin

4.b

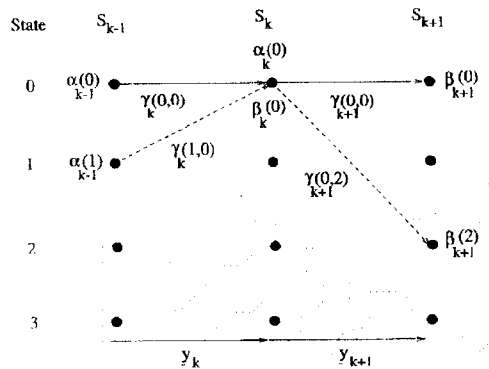

• Summary of MAP Algorithm

• From the previous description, we see that the MAP decoding of a received sequence \tilde{y}_k to give the a-posteriori LLR $L(u_k | \tilde{y})$ can be carried out as follows.

1. The a-priori LLRs $L(u_k)$ (which are provided in an iterative turbo decoder by the other component decoder) are used to calculate $\gamma_k(s', s)$ using

$$\gamma_k(s', s) = f(\tilde{y}_k | \tilde{u}_k) P(u_{k,1})$$

Where

$$P(u_{k,1} = \pm 1) = \frac{\exp(-L(u_k)/2)}{1 + \exp(-L(u_k))} \exp\left(u_k \frac{L(u_k)}{2}\right)$$

And

$$f(\tilde{y}_k | \tilde{u}_k) = \prod_{i=1}^n \frac{1}{\sqrt{\pi N_0}} \exp\left(-\frac{1}{N_0} (y_{ki} - u_{ki})^2\right)$$

2. The forward recursion equation

$$\alpha_k(s) = \sum_{\text{all } s'} \gamma(s', s) \alpha_{k-1}(s') \text{ is used to calculate } \alpha_k(s)$$

3. The backward recursion equation

$$\beta_{k-1}(s') = \sum_{\text{all } s} \beta_k(s) \gamma_k(s', s) \text{ is used to calculate } \beta_{k-1}(s')$$

4. Finally, all the calculated values of $\gamma_k(s', s)$, $\alpha_k(s)$ and $\beta_{k-1}(s')$ are used to calculate the condition LLR function

$$L(u_k | \tilde{y}) = \ln \frac{\sum_{(s', s) = u_k = +1} \alpha_{k-1}(s') \gamma_k(s', s) \beta_k(s)}{\sum_{(s', s) = u_k = -1} \alpha_{k-1}(s') \gamma_k(s', s) \beta_k(s)}$$