

Paper Number(s): **E3.07**
ISE3.11

IMPERIAL COLLEGE OF SCIENCE, TECHNOLOGY AND MEDICINE
UNIVERSITY OF LONDON

DEPARTMENT OF ELECTRICAL AND ELECTRONIC ENGINEERING
EXAMINATIONS 2002

EEE/ISE PART III/IV: M.Eng., B.Eng. and ACGI

DIGITAL SIGNAL PROCESSING

Thursday, 2 May 10:00 am

There are SIX questions on this paper.

Answer FOUR questions.

Corrected Copy

Time allowed: 3:00 hours

Examiners responsible:

First Marker(s): Naylor, P.A.

Second Marker(s): Mandic, D.P.

Special Instructions for Invigilators: None

Information for Candidates:

Sequence	z-transform
$\delta(n)$	1
$u(n)$	$\frac{1}{1-z^{-1}}$
$a^n u(n)$	$\frac{1}{1-az^{-1}}$

Table 1 : z-transform pairs

$\delta(n)$ is defined to be the unit impulse function.

$u(n)$ is defined to be the unit step function.

Numbers in square brackets against the right margin of the following pages are a guide to the marking scheme.

1. Consider a Bartlett window for N odd,

$$w_B(n) = 1 - \frac{|2n - N + 1|}{N + 1} \quad 0 \leq n \leq N - 1$$

and a rectangular window function

$$w_r(n) = \begin{cases} 1, & 0 \leq n < (N + 1) / 2 \\ 0, & \text{otherwise} \end{cases}$$

Let $N = 21$.

- (a) Show that the Bartlett window can be obtained from [6]

$$\frac{2}{N + 1} \{w_r * w_r\}$$

where $*$ indicates convolution.

- (b) Draw a labelled sketch of the Bartlett window. [4]

- (c) Show that the Fourier Transform of $w_B(n)$ can be written [6]

$$W_B(k) = \frac{2 \sin^2(0.25\theta(N + 1))}{(N + 1) \sin^2(0.5\theta)} e^{-j0.5\theta(N-1)}$$

You may use the result that the sum of the first M terms of a geometric series

$$a + ar + ar^2 + \dots \text{ can be written as } \frac{a(1 - r^M)}{1 - r}.$$

- (d) Derive the value of $|W_B(0)|$. [2]
- (e) Sketch the function $|W_B(k)|$. It is only necessary to show the significant features and general shape of the function. [2]

2. A type of FIR filter of even order $N = 2M$ has coefficients $h(n) = -h(N - n)$ and $h(M) = 0$.

Show that the frequency response of the filter can be written in the form

$$H(\theta) = e^{jA} \sum_{n=0}^{M-1} 2 h(n) \sin(B) \quad [9]$$

and write out the expressions for A and B .

Deduce the following properties of $H(\theta)$: [3]

- (i) the phase of the frequency response at $\theta = 0$.
- (ii) the magnitude of the frequency response at $\theta = 0, \pi$ and 2π .

Briefly propose a suitable application for this filter using a short paragraph of description and, if appropriate, a sketch graph. [3]

A particular design of this type of filter has

$$\begin{aligned} N &= 6 \\ h(0) &= 1.0 \\ h(1) &= 0.5 \\ h(2) &= -0.3 \end{aligned}$$

Compute the unit step response of this filter. [2]

Sketch a plot of the magnitude of the frequency response. [3]

3. Define the DTFT of a sequence $x(n)$. [4]

Discuss the differences and relationships between the DTFT and the DFT and, hence, formulate an expression for the DFT from that of the DTFT. [4]

The difference equation of a causal system $H(z)$ is of the form

$$y(n) = \sum_{k=1}^p a_k y(n-k) + x(n).$$

By considering the impulse response of this system, find $H(e^{j\omega})$ at the frequencies $\omega_k = 2\pi k/4$, $k = 0, 1, 2, 3$ giving your answer in terms of the coefficients a_k . [8]

Summarise briefly how you would test whether $H(z)$ represents a stable system. Give particular consideration to two cases:

- (i) $p = 2$ (ii) $p = 16$ [4]

4. (a) State the definition of the DFT $X(k)$ of a sequence $x(n)$. If $x(n)$ is a 2-point sequence, determine its DFT. [3]
- (b) Show that a 4-point DFT can be expressed in terms of two 2-point DFTs. Illustrate your solution using a signal flow graph and include equations for all nodes of the flow graph as well as the outputs. [7]
- (c) (i) Derive the complexity of the DFT of N samples in terms of the number of complex multiplications. State any constraints on N . [1]
- (ii) Derive the complexity of the Radix-2 Decimation-in-time FFT of N samples in terms of the number of butterflies. State any constraints on N . [4]
- (iii) Hence determine the ratio of the complexity of the DFT to the complexity of the Radix-2 Decimation-in-time FFT for $N = 1024$, given that each butterfly operation requires one complex multiply. [2]
- (iv) Repeat the complexity comparison of part (iii) for $N = 1025$. [3]

5. Consider a real data sequence $x(n)$ and two related sequences:
 $x_{\downarrow M}(n)$ obtained by decimating $x(n)$ by a factor M and
 $x_{\uparrow L}(n)$ obtained by expanding $x(n)$ by a factor of L .

- (a) Prove that, if M and L are coprime then [6]

$$(x_{\downarrow M})_{\uparrow L}(n) = (x_{\uparrow L})_{\downarrow M}(n)$$

For $x(n)$ written as the sequence $\{x(0), x(1), x(2), x(3), \dots\}$, verify this theorem by determining the sequences for $(x_{\downarrow M})_{\uparrow L}(n)$ and $(x_{\uparrow L})_{\downarrow M}(n)$ for the two cases

- (i) $M = 3, L = 2,$ [4]
(ii) $M = 6, L = 4.$

- (b) Let $x(n) = \alpha^n, n \geq 0.$

Write down expressions for

- (i) $X(z)$, obtained by taking the z -transform of $x(n)$ [2]
(ii) $x_{\downarrow M}(n)$ [2]
(iii) $X_{\downarrow M}(z)$, obtained by taking the z -transform of $x_{\downarrow M}(n)$ [2]

and show that $X_{\downarrow M}(z)$ can also be written $\frac{1}{M} \sum_{m=0}^{M-1} \frac{z^{1/M} W_M^{-m}}{z^{1/M} W_M^{-m} - \alpha}$ where W_M has the usual meaning. [4]

Note that it is sufficient to state, without derivation, any multirate identities employed.

6. A recursive digital filter is described by the difference equation

$$y(n) = b_0 x(n) + a_1 y(n-1) + a_2 y(n-2).$$

The filter's magnitude response has unity gain at a normalised frequency of $\pi/2$ and 20dB of loss at frequencies of 0 and π .

- (a) Draw a labelled sketch of the magnitude response. [4]
(b) Consider suitable approximate locations for the poles and zeros of the filter and sketch them on a z -plane plot. Include a brief explanation of your reasoning. [6]
(c) Determine specific values for b_0, a_1 and a_2 and draw a labelled signal flow graph for the filter. [8]
(d) Sketch the phase response of your filter. [2]

SOLUTIONS

1. From the convolution sum

$$y(n) = w_r * w_r = \sum_m w_r(m)w_r(n-m)$$

or the graphical method we obtain two straight line segments of unit gradient.

Consider the term $2n-(N-1)$ for two cases:

$$2n \leq N-1:$$

$$w_B(n) = n+1$$

$$2n > N-1:$$

$$w_B(n) = N-n$$

and hence we obtain the expression for $w_B(n)$.

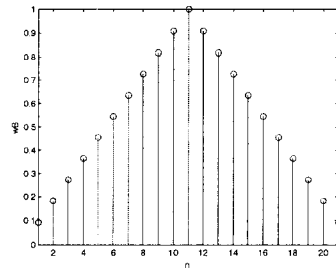

To derive the FT, first consider the rectangular window of length M which has FT given by

$$W_r(k) = \sum_{n=0}^{M-1} e^{-jn\theta} = \frac{1-e^{-j\theta M}}{1-e^{-j\theta}} = \frac{2e^{-j\theta M/2} \sin(\theta M/2)}{2e^{-j\theta/2} \sin(\theta/2)} = \frac{\sin(\theta M/2)}{\sin(\theta/2)} e^{-j\frac{\theta}{2}(M-1)}$$

The convolution in the time domain gives rise to multiplication in the frequency domain so that

$$W_B(k) = \frac{2}{N+1} \left(\frac{\sin(\theta M/2)}{\sin(\theta/2)} e^{-j\frac{\theta}{2}(M-1)} \right)^2$$

and for our case we require $M = \frac{N+1}{2}$ hence

$$\begin{aligned} W_B(k) &= \frac{2}{N+1} \left(\frac{\sin(\theta(N+1)/4)}{\sin(\theta/2)} e^{-j\frac{\theta}{4}(N-1)} \right)^2 \\ &= \frac{2}{N+1} \left(\frac{\sin^2(\theta(N+1)/4)}{\sin^2(\theta/2)} e^{-j\frac{\theta}{2}(N-1)} \right) \end{aligned}$$

For $\theta \rightarrow 0$, we have

$$|W_B(\theta)|_{\theta \rightarrow 0} = \frac{2}{N+1} \left(\frac{0.25(N+1)}{0.5} \right)^2 = \frac{N+1}{2} = 11$$

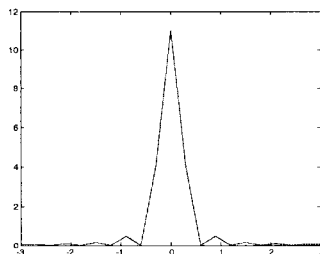

2.

$$\begin{aligned}
 H(\theta) &= \sum_{n=0}^{M-1} h(n).e^{-jn\theta} + \sum_{n=M+1}^{2M} h(n).e^{-jn\theta} \\
 &= \sum_{n=0}^{M-1} h(n).e^{-jn\theta} + \sum_{n=M-1}^0 h(N-n).e^{-j(N-n)\theta} \\
 &= \sum_{n=0}^{M-1} h(n).e^{-jn\theta} + \sum_{n=0}^{M-1} h(N-n).e^{-j(N-n)\theta} \\
 &= e^{-jM\theta} \left[\sum_{n=0}^{M-1} h(n).e^{j\theta(M-n)} + \sum_{n=0}^{M-1} h(N-n).e^{-j\theta(M-n)} \right] \\
 &= e^{j(\pi/2-M\theta)} \sum_{n=0}^{M-1} h(n).2 \sin(\theta(M-n))
 \end{aligned}$$

Because filter has zeros at $n\pi$, not suitable for highpass or lowpass or bandstop applications. Can be used for bandpass.

Unit step response: 1.0 1.5 1.2 1.2 1.5 1.0 0

Magnitude response:

Zeros at 0, π and at θ whenever $(\theta(3-n)) = 0, \pi, \dots$

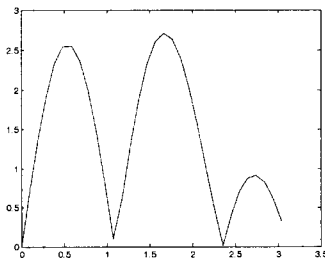

3.

$$X(e^{j\omega}) = \sum_{n=-\infty}^{\infty} x(n)e^{-jn\omega T}$$

DTFT is computed over an infinite range of n and yields a continuous function of frequency. DFT is computed over a finite range of n and yields a sampled version of the DTFT, sampled at equal intervals around the unit circle in z .

To obtain the DFT from the DTFT, let ω be replaced by $k\omega_0$, $\omega_0 = \frac{2\pi}{NT}$.

Frequency response at these frequencies can be found from the DFT of the first 4 samples of the impulse response.

Impulse response:

$$h(0) = 1$$

$$h(1) = a_1$$

$$h(2) = a_1a_1 + a_2$$

$$h(3) = a_1(a_1a_1 + a_2) + a_2a_1 + a_3$$

Frequency response (from DFT):

$$H(e^{j0}) = h(0) + h(1) + h(2) + h(3)$$

$$H(e^{j\omega_0}) = h(0) - jh(1) - h(2) + jh(3)$$

$$H(e^{j2\omega_0}) = h(0) - h(1) + h(2) - h(3)$$

$$H(e^{j3\omega_0}) = h(0) + jh(1) - h(2) - jh(3)$$

Stability:

- For p small, root finding is feasible and stability can be shown for cases when all the roots have modulus less than unity.
- For p large, root find is not feasible but the Schur-Cohn test can be employed to obtain the parcor (reflection) coefficients and stability can be shown if all such coefficients have modulus less than unity.

4. (a)
$$X(k) = \sum_{n=0}^{N-1} x(n)e^{-jkn2\pi/N} \quad k = 0, 1, 2, \dots, N-1$$

For $N = 2$, $X(0) = x(0) + x(1)$ and $X(1) = x(0) - x(1)$.

- (b) The solution comes from a decimation-in-time of the input sequence, giving rise to a reordering of the samples, 2 2-point DFTs and the recombination equations.

$$X_1(0) = x(0) + x(2)$$

$$X_1(1) = x(0) - x(2)$$

$$X_2(0) = x(1) + x(3)$$

$$X_2(1) = x(1) - x(3)$$

$$X(0) = X_1(0) + X_2(0)$$

$$X(1) = X_1(1) + W_4^1 X_2(1)$$

$$X(2) = X_1(0) - X_2(0)$$

$$X(3) = X_1(1) - W_4^1 X_2(1)$$

- (c) (i) The complexity of the DFT is N^2 for any N .

- (ii) We always require $N/2$ butterflies to calculate the 2-point DFTs.

The number of subsequent recombination stages satisfies $\frac{N}{2^R} = 2$ so that $R = \log_2 N - 1$.

The number of butterflies equals the number of stages times the number of butterflies per stage.

Total number of stages (DFTs plus recombination) is $\log_2 N$.

Number of butterflies per stage is always $N/2$ hence total is $\frac{N}{2} \log_2 N$.

N must be integer power of 2.

- (iii) For $N = 1024$, DFT requires 1048576 and FFT requires 5120 giving a ratio of 204.8.

- (iv) For $N = 1025$, it is not possible to use the FFT directly. It is necessary to zero-pad first thereby increasing the length to the next integer power of 2, i.e. 2048. The complexity of DFT stays the same but the complexity of FFT becomes 11264 giving a new ratio of 93.1.

5. From the definitions we have

$$(x_{\downarrow M})_{\uparrow L}(n) = \begin{cases} x(nM/L), & nM \text{ divisible by } L \\ 0, & \text{otherwise} \end{cases}$$

$$(x_{\uparrow L})_{\downarrow M}(n) = \begin{cases} x(nM/L), & n \text{ divisible by } L \\ 0, & \text{otherwise} \end{cases}$$

When M and L are coprime, nM is divisible by L iff n is divisible by L .

For $M=3, L=2$, both sequences are $\{x(0), 0, x(3), 0, x(6), 0, \dots\}$.

For $M=6$ and $L=4$ we have the counter example:

$$(x_{\downarrow M})_{\uparrow L}(n) = \{x(0), 0, 0, 0, x(6), 0, 0, 0, x(12), 0, 0, \dots\}$$

$$(x_{\uparrow L})_{\downarrow M}(n) = \{x(0), 0, x(3), 0, x(6), 0, \dots\}.$$

$$(i) \quad X(z) = \frac{z}{z - \alpha}$$

$$(ii) \quad x_{\downarrow M}(n) = \alpha^{Mn}, \quad n \geq 0$$

$$(iii) \quad X_{\downarrow M}(z) = \frac{z}{z - \alpha^M}$$

We can use the general expression, without derivation, that $X_{\downarrow M}(z) = \frac{1}{M} \sum_{m=0}^{M-1} X(z^{1/M} W_M^{-m})$. The

final result is obtained by substituting the solution of (i) into this expression and replacing z with $z^{1/M} W_M^{-m}$.

6.

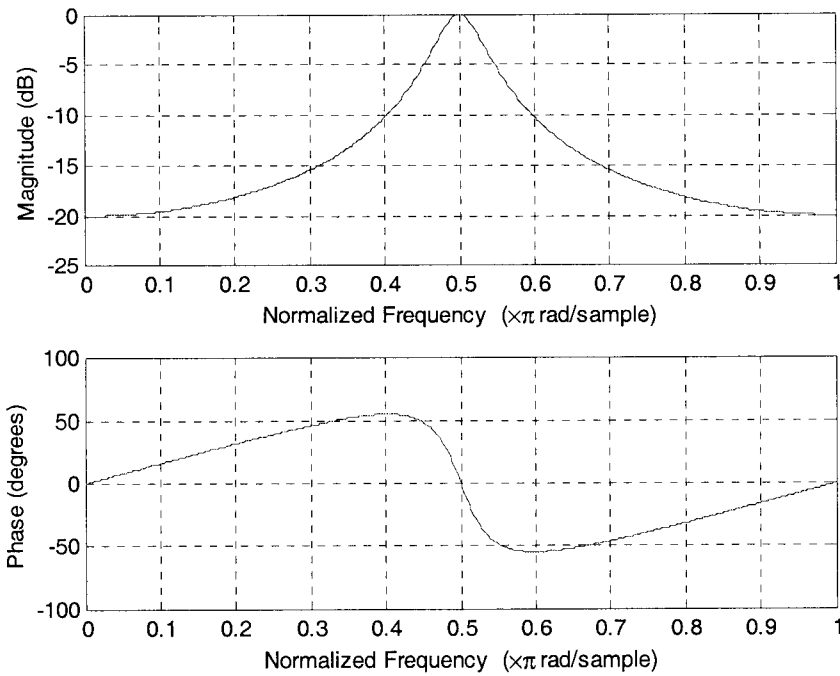

The filter is bandpass with a centre frequency of $\pi/2$. The magnitude of frequency response will exhibit this behaviour if poles are located on the imaginary axis, relatively close to, but inside, the unit circle.

Denote the pole locations as $\lambda e^{\pm j\pi/2}$.

The filter will have two zeros at the origin.

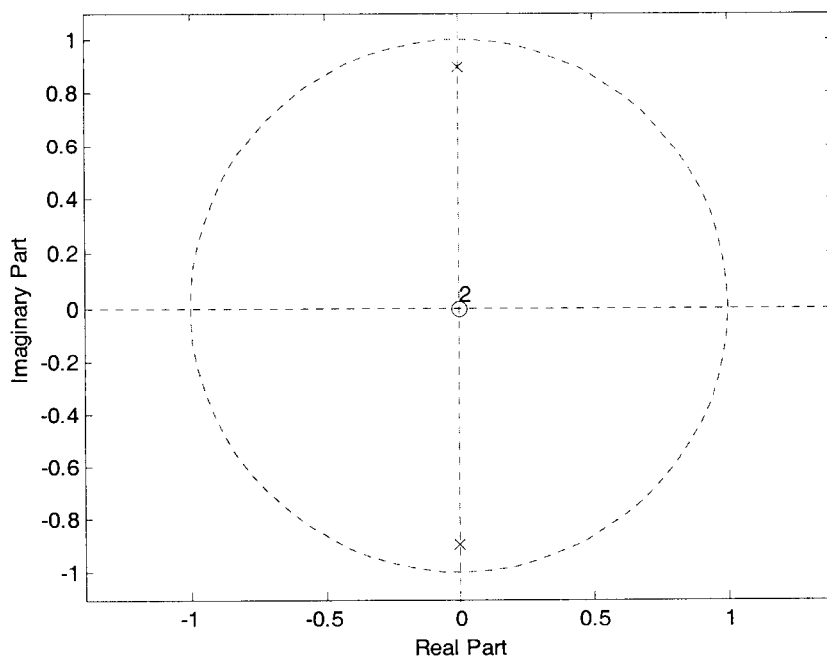

We can write the transfer function as

$$H(z) = \frac{b_0 z^{-2}}{(z - \lambda e^{j\pi/2})(z - \lambda e^{-j\pi/2})}$$

To satisfy the design criteria we require

$$|H(e^{j\omega})| = 1 \text{ for } \omega = \frac{\pi}{2} \text{ and}$$

$$|H(e^{j\omega})| = 0.1 \text{ for } \omega = 0, \pi$$

This yields simultaneous equations:

$$\frac{b_0}{1 - \lambda^2} = 1 \text{ and } \frac{b_0}{1 + \lambda^2} = 0.1$$

which can be solved to show $\lambda = 0.9045$ and $b_0 = 0.1818$.

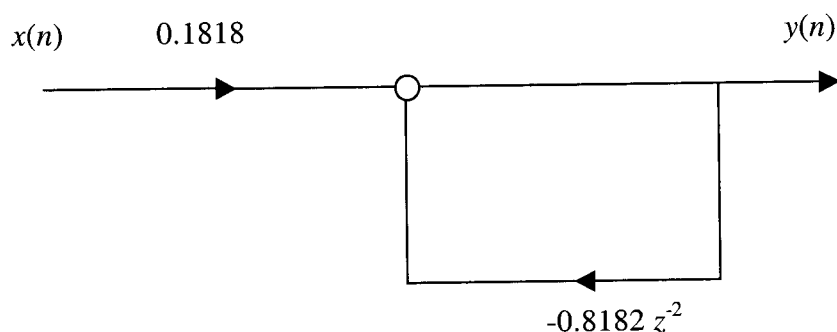

Since the frequency response is real at frequencies of $0, \pi/2$ and π , the phase must be zero at these frequencies. The phase angle at other frequencies can be determined graphically as

$$\sum \text{angles to all zeros} - \sum \text{angles to all poles}$$

for a small number of frequencies. It is only necessary to correctly show the zero crossings and general shape of the phase response in order to obtain full marks for this part of the question.