

Paper Number(s): **E2.4**
ISE2.4

IMPERIAL COLLEGE OF SCIENCE, TECHNOLOGY AND MEDICINE
UNIVERSITY OF LONDON

DEPARTMENT OF ELECTRICAL AND ELECTRONIC ENGINEERING
EXAMINATIONS 2002

EEE/ISE PART II: M.Eng., B.Eng. and ACGI

COMMUNICATIONS II

Wednesday, 22 May 2:00 pm

There are FIVE questions on this paper.

Answer THREE questions.

Time allowed: 2:00 hours

Examiners responsible:

First Marker(s): Ward, D.B.

Second Marker(s): Barria, J.A.

Corrected Copy

None

1. (a) Consider the communications system shown in the following diagram

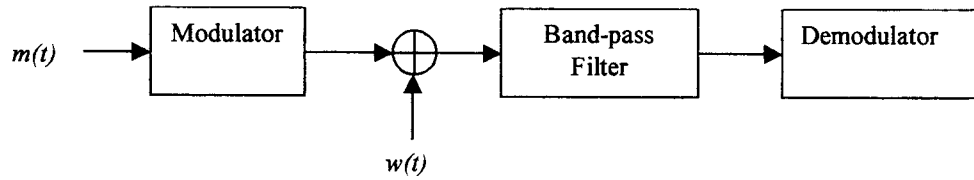

where $m(t)$ is the base-band message signal, $w(t)$ is additive zero-mean Gaussian noise with a flat power spectral density of height $N_o / 2$, and the band-pass filter has a pass band (of appropriate width) centered on the carrier frequency ω_c .

Show that the noise component of the signal at the output of the band-pass filter can be represented as: $n(t) = \sum_k a_k \cos(\omega_k t + \theta_k)$.

Also show that this noise can be written as: $n(t) = n_c(t) \cos \omega_c t - n_s(t) \sin \omega_c t$

[10]

- (b) With reference to the system in part (a), if the message signal has a bandwidth of 15 kHz, and the noise has $N_o = 2 \times 10^{-6}$, calculate the average power in $n(t)$ for each of the following modulation schemes:

- (i) DSB-SC
- (ii) FM with a modulation index of $\beta = 3$.

[5]

- (c) A noise signal with the power spectral density shown here:

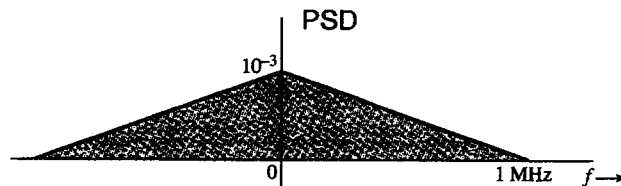

is passed through the band-pass filter shown here:

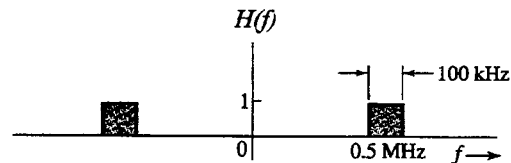

Draw the power spectral densities of the base-band components $n_c(t)$ and $n_s(t)$ at the output of the filter. Also calculate the average power in each base-band component.

Assume that the center frequency in the band-pass representation is $f_c = 0.5$ MHz.

[5]

2. (a) Consider an AM receiver consisting of an ideal band-pass filter followed by an envelope detector. Assume the input to the band-pass filter consists of the AM signal:

$$s_{\text{AM}}(t) = [A_c + m(t)] \cos \omega_c t$$

plus zero-mean Gaussian noise with a flat power spectral density. If the noise power is much greater than the power of the carrier and the message, show that the output of the receiver is:

$$y(t) = R(t) + [A_c + m(t)] \cos \phi(t),$$

where $R(t) = \sqrt{n_c^2(t) + n_s^2(t)}$, and $\tan \phi(t) = n_s(t) / n_c(t)$.

You may find the following relationship useful: $\sqrt{1+x} \approx 1 + \frac{x}{2}$ for $x \ll 1$.

[8]

- (b) With the reference to the output expression $y(t)$ of the system in part (a), explain why an AM receiver using an envelope detector exhibits a threshold effect.

[4]

- (c) Consider an FM receiver consisting of an ideal band-pass filter followed by an FM demodulator. If the carrier power is much greater than the noise power at the output of the band-pass filter, then the signal-to-noise ratio at the output of the receiver is given by:

$$SNR_o = 3\beta^2 \frac{P}{[\max m(t)]^2} SNR_{\text{base}}$$

where P is the average power of the message signal $m(t)$, and we assume that the noise is zero-mean Gaussian with a flat power spectral density.

Explain why SNR_o cannot be increased arbitrarily simply by increasing β .

HINT: The transmission bandwidth of FM is given by Carson's rule: $B_T = 2(\beta + 1)W$

[4]

- (d) Explain pre-emphasis and de-emphasis and why it is used in FM systems.

[4]

3. (a) Using the Huffman coding procedure, construct a coding scheme for an alphabet whose symbols occur independently with probabilities 0.15, 0.08, 0.25, 0.10, 0.30, 0.12. Calculate the average codeword length of the resulting coding scheme, and compare it with the source entropy. [10]
- (b) What is the major practical disadvantage of Huffman coding? [2]
- (c) State the channel capacity theorem. Also give the Hartley-Shannon expression for channel capacity, explaining and giving units for all terms used. [6]
- (d) Explain the difference between source coding and channel coding. [2]

4. (a) A signal $m(t)$ that is band-limited to 3 kHz is sampled at a rate $33\frac{1}{3}\%$ higher than the Nyquist rate. The maximum acceptable error in the sample amplitude (i.e., the maximum quantization error) is 0.5% of the peak amplitude of $m(t)$. The quantized samples are binary coded. Find the minimum bandwidth of a channel required to transmit the encoded binary signal. Assume that a channel of bandwidth B Hz can transmit $2B$ bits of information per second.

[8]

- (b) The input to a uniform n -bit quantizer is the periodic triangular waveform shown below, which has a period of $T = 4$ seconds, and an amplitude that varies between +1 volt and -1 volt.

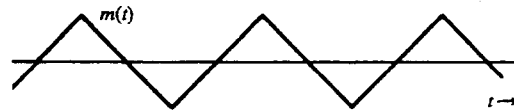

Derive an expression for the signal-to-noise ratio (in decibels) at the output of the quantizer. Assume that the dynamic range of the quantizer matches that of the input signal. Note that the mean-square error of a uniform quantizer is $\Delta^2/12$, where Δ is the quantizer step size.

[4]

- (c) Consider the synchronous FSK detector shown in the figure below, where the input to the detector is an FSK signal.

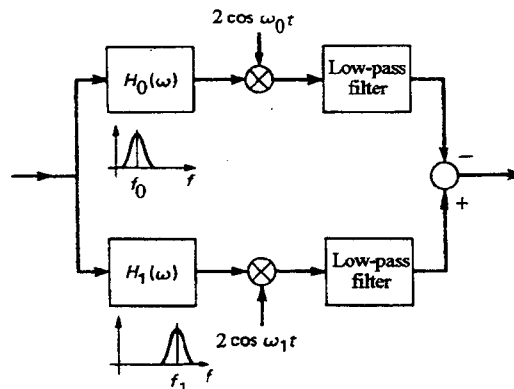

Also consider the synchronous PSK detector shown in the figure below, where the input to the detector is a PSK signal.

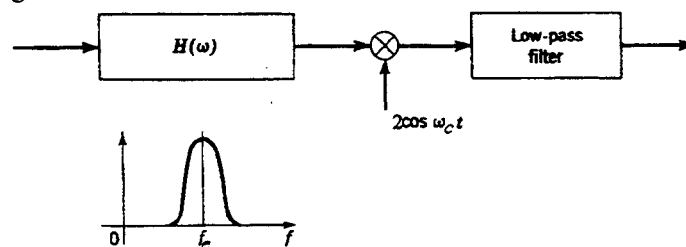

Show that the average power of the noise at the FSK detector output is twice that of the noise at the PSK detector output.

Assume in each case that the noise at the receiver input is additive zero-mean Gaussian noise with a flat power spectral density.

[8]

5. Answer any two of the following subsections (a), (b), and (c).

(a) Briefly describe each of the following transmission media, and give a typical application of each:

- (i) twisted pair
- (ii) coaxial cable
- (iii) microwave
- (iv) optical fiber
- (v) broadcast wireless

[10]

(b) Briefly describe and contrast the following switching techniques:

- (i) circuit switching
- (ii) message switching
- (iii) packet switching

[10]

(c) Describe the differences between wide area networks (WANs) and local area networks (LANs). You can refer to the different functions in each of the appropriate levels in the OSI protocol reference model to elaborate your answer.

[10]

Q1 SOLUTIONS - COMMUNICATIONS II
2002

(a) White Gaussian noise has the PSD:

1/13

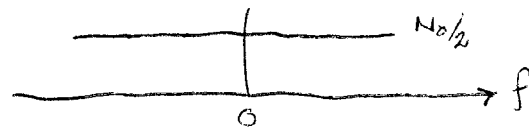

After the BPF this is:

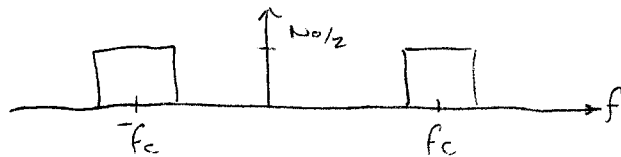

Consider a small range of frequencies in this signal, about a frequency f_k , i.e.:

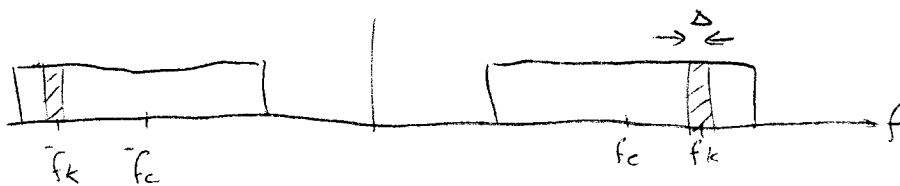

For Δf small, the shaded components can be represented as the cos wave:

$$n_k(t) = a_k \cos \omega_k t + \theta_k$$

where a_k is random amplitude of θ_k is random phase.

Summing up over all such f_k in the band, we have:

$$(5) \quad n(t) = \sum_k n_k(t) = \sum_k a_k \cos(\omega_k t + \theta_k)$$

Let $\omega_k = \omega_c - \omega_c + \omega_c$, & use $\cos(A+B) = \cos A \cos B - \sin A \sin B$

$$\therefore n_k(t) = a_k \cos((\omega_k - \omega_c)t + \theta_k) \cos \omega_c t - a_k \sin((\omega_k - \omega_c)t + \theta_k) \sin \omega_c t$$

Hence, $n(t) = n_c(t) \cos \omega_c t - n_s(t) \sin \omega_c t$

where $n_c(t) = \sum_k a_k \cos((\omega_k - \omega_c)t + \theta_k)$

$$(5) \quad n_s(t) = \sum_k a_k \sin((\omega_k - \omega_c)t + \theta_k)$$

Q1

(b)

$W = 15 \times 10^3$, $N_0 = 2 \times 10^{-6}$ $\therefore N_0/2 = 1 \times 10^{-6}$

(i) for DSB-SC, the transmission b/w is $B_T = 2W$, so the PSD of the noise after the BPF is:

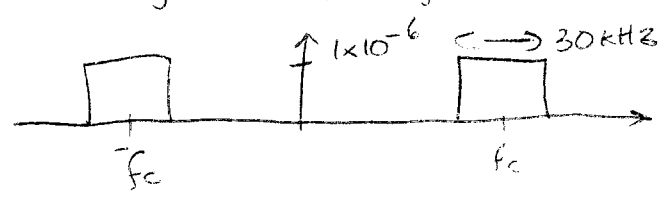

Thus, the average power is:

$$P = \int_{-\infty}^{\infty} \text{PSD} df = 2 \times \text{area under each above}$$

$$= 2 \times 1 \times 10^{-6} \times 30 \times 10^3$$

$$= 0.06 \text{ Watts.}$$

2

(ii) for FM, transmission b/w by Carson's rule is $B_T = 2(\beta + 1)W = 120 \text{ kHz.}$

Avg power of noise after BPF is therefore:

$$P = 2 \times 1 \times 10^{-6} \times 120 \text{ kHz}$$

$$= 0.24 \text{ Watts}$$

3

(a)

3/17

(c)

PSD of $n(t)$ is:

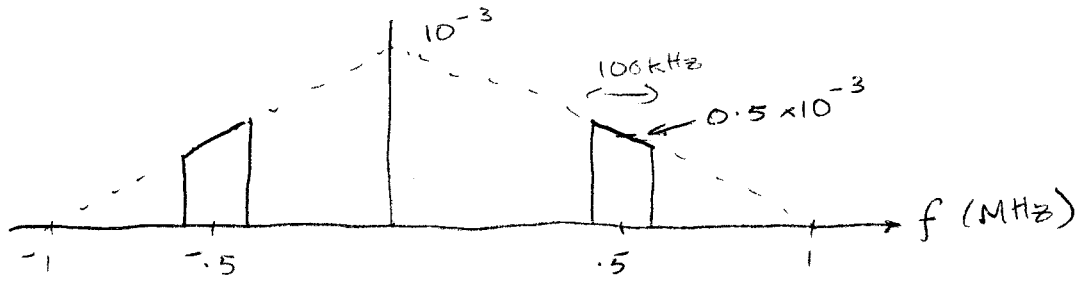

\therefore PSD of $n_c(t)$ & $n_s(t)$ are both:

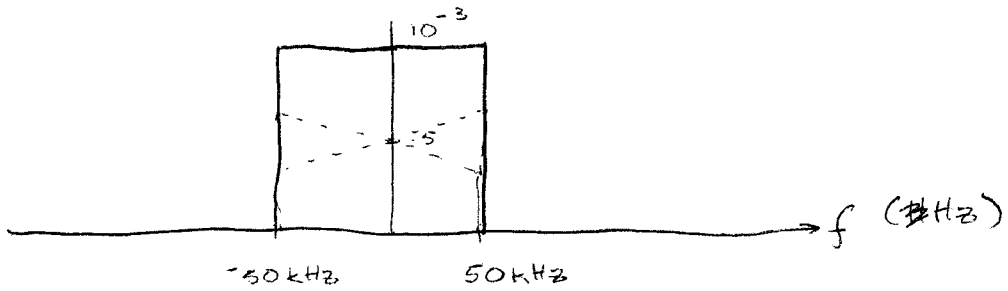

Avg power is:

$$P = 100 \times 10^3 \times 1 \times 10^{-3} = 100 \text{ Watts.}$$

QUESTION 2

4/13



After BPF, signal is:

$$\begin{aligned}
 x(t) &= s(t) + n_c(t) \cos \omega_c t - n_s(t) \sin \omega_c t \\
 &= [A_c + m(t) + n_c(t)] \cos \omega_c t - n_s(t) \sin \omega_c t
 \end{aligned}$$

Phasor diagram is:

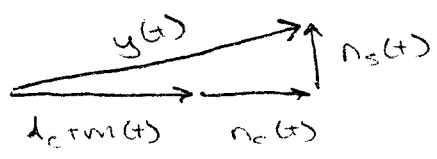

Output of env. det. will be:

$$\begin{aligned}
 y(t) &= \sqrt{(A_c + m(t) + n_c(t))^2 + n_s^2(t)} \\
 &= \sqrt{(A_c + m(t))^2 + 2(A_c + m(t))n_c(t) + n_c^2(t) + n_s^2(t)}
 \end{aligned}$$

But $n_c(t) \gg A_c + m(t)$, so $n_s(t) + n_c(t) \gg A_c + m(t)$

$$\therefore y(t) \approx \sqrt{n_c^2(t) + n_s^2(t) + 2(A_c + m(t))n_c(t)}$$

But,

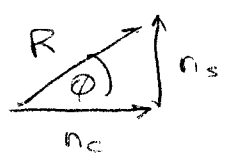

$$\begin{aligned}
 R^2 &= n_c^2 + n_s^2 \\
 n_c &= R \cos \phi
 \end{aligned}$$

$$\begin{aligned}
 \therefore y(t) &= \sqrt{R^2 + 2R \cos \phi (A_c + m(t))} \\
 &= \sqrt{R^2 [1 + 2 \cos \phi / R (A_c + m(t))]} \\
 &= R \sqrt{1 + 2/R \cos \phi (A_c + m(t))} \\
 &\approx R [1 + \frac{1}{2} \cos \phi (A_c + m(t))] \quad \text{using given expression} \\
 &= R + \cos \phi [A_c + m(t)]
 \end{aligned}$$

(8)

Q2

5/13

(b) The o/p of the env. det. consists of $m(t)$ multiplied by a time-varying noise term $G_s \phi(t)$. Hence, it is of no use in recovering the message $m(t)$. Because the noise is multiplicative when the noise increases above a certain level, the env. det. has a threshold effect.

(-1)

(c) Because the ~~bandwidth~~ noise power at the o/p of the BPF is related to the transmission b/w, if β is increased the noise power also increases. At some stage the requirement that the carrier power is much greater than noise power is violated. Hence, SNR cannot be arbitrarily increased.

(-1)

(d) PSD of noise at o/p of FM detector is of the form:



whereas PSD of most message signals is of the form:

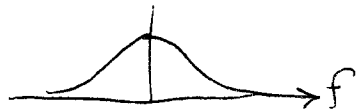

Thus, at high freqs the SNR is very poor.

Pre-emph is used to boost high freq components of message prior to FM modulation, thereby improving SNR.

De-emph performs inverse operation by de-emphasizing high freq components, thereby leaving message undistorted.

(-1)

QUESTION 3

(a)

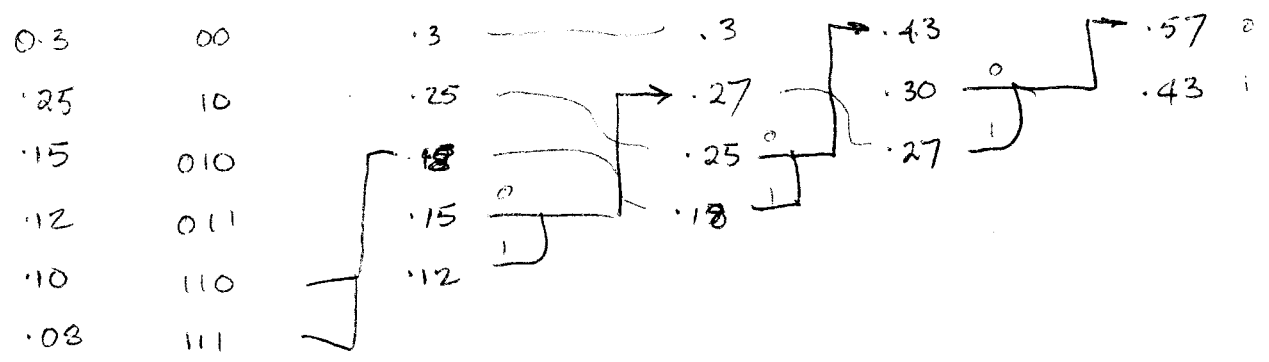

Avg length: $L = \sum p_k \cdot l_k$
 $= .3 \times 2 + .25 \times 2 + .15 \times 3 + .12 \times 3 + .1 \times 3 + .08 \times 3$
 $= 2.45 \text{ bits}$

(10) Entropy: $H = -\sum p_k \log_2 p_k$
 $= 2.418 \text{ bits}$

(b) Major disadvantage of Huffman is that it a priori requires source statistics. In many practical cases these are not known.

(2)

(c) Channel capacity: If info rate, $R \leq C$ (channel capacity) then there exists a coding scheme such that source can be transmitted over a noisy channel with an arbitrarily small prob. of error.

Hartley-Shannon: $C = B \log_2 (1 + S/N)$

where C is channel capacity in bits/sec
 B is channel b/w in Hz
 S is avg sig power at receiver input in Watts
 N is avg noise power at receiver input in Watts

(6)

Q3

(d) Source coding: concerned with assigning binary codewords to source symbols.

Channel coding: concerned with introducing redundant bits to enable receiver to detect/correct errors introduced by channel

②

QUESTION 4

(a) Nyquist sampling rate is 6000 samples/sec. So actual sampling rate is:

$$f_s = 6000 \times 1\frac{1}{3} = 8000 \text{ Hz.}$$

Quant. step size is Δ , so max error is $\Delta/2$.

If there are L levels, then the step size is:

$$\Delta = \frac{2 \times \text{peak}}{L} \quad \text{where peak is max sig amplitude}$$

We require $\Delta/2 < \frac{0.5}{100} \text{ peak.}$

$$\text{i.e. } \frac{\text{peak}}{L} < \frac{0.5}{100} \text{ peak}$$

$$\text{i.e. } L > 200.$$

Since L must be a power of 2 for a binary code, we choose $L = 256$, requiring $\log_2 256 = 8$ bit quantised. Hence, each sample requires 8 bits, so sampling at 8 kHz requires 64 000 bits/s.

(8)

Hence, we require a b/w of $\frac{64000}{2} = 32 \text{ kHz.}$

(b)

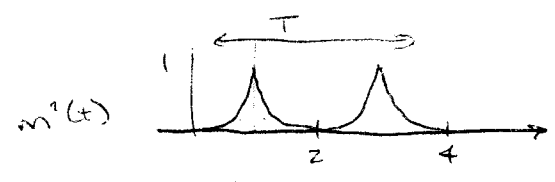

Signal power, $P = \frac{1}{T} \int_0^T m^2(t) dt$
 $= \frac{4}{T} \int_0^1 m^2(t) dt$ because of symmetry
 $= \int_0^1 t^2 dt$
 $= \frac{1}{3}$

Noise power, $N = \Delta^2/12$
 where $\Delta = 2/2^n$

(4)

$$\therefore N = \frac{4 \times 2^{-2n}}{12} = \frac{1}{3} 2^{-2n}$$

$$\therefore \text{SNR} = \frac{\frac{1}{3}}{\frac{1}{3}} 2^{2n} \quad \therefore \text{SNR}_{\text{dB}} = 10 \log_{10}(2^{2n})$$

$$= 20n \log_{10} 2 = 6.02n.$$

Q4

9
17

(c)

Consider the FSK system.

If the input is AWGN, then;

(i) Upper-branch:

- after BPF, $n_o(t) = n_c^o(t) \cos \omega_c t - n_s^o(t) \sin \omega_c t$

- after multiplier, signal is:

$$2n_o(t) \cos \omega_c t = n_c^o(t) (1 + \cos 2\omega_c t) - n_s^o(t) \sin 2\omega_c t$$

- after LPF, noise = $n_c^o(t)$

(ii) Lower-branch,

- after LPF, noise = $n_s^o(t)$

If $H_o(\omega)$ & $H_l(\omega)$ do not overlap, then $n_c^o(t)$ & $n_s^o(t)$ are uncorrelated, & noise at output, i.e. $n_c^o(t) - n_s^o(t)$ has variance that is twice the variance of each.

For PSK, noise at o/p will have same variance as $n(t)$ which is same as $n_c(t)$

Here, FSK noise has twice variance of PSK noise.

For zero-mean Gaussian signal, avg power = variance.

Here, FSK noise has twice the power of PSK noise.

8

QUESTION 5

10
17

(a)

(i) Twisted pair:

- consists of two insulated copper wires
- application is to connect individual residential telephones to local exchange

(ii) Coax:

- consists of hollow outer cylindrical conductor that surrounds a single inner wire conductor
- applications are TV, long-distance phones, LANs

(iii) microwave:

- uses parabolic dish for directional transmission over the air
- primary application is long-haul telecommunication

(iv) optical fibre:

- consists of 3 concentric sections: core (one or more fibers), cladding (glass/plastic coating with different optical props) & jacket (protective covering)
- applications are long-haul trunks, LANs

(v) ~~wireless~~ broadcast radio:

- omnidirectional over air, so no need for directional antennas
- application is commercial radio, UHF & VHF TV.

(10)

(2 for each)

Q5

11/13

(b)

Circuit switching:

- dedicated comm. path is established between two stations through nodes of the network

- phases are:

(i) establishment \rightarrow an end-to-end circuit is established before data can be transmitted

(ii) data transfer \rightarrow data can only be transmitted from the originating station to destination station; usually full duplex

(iii) disconnect \rightarrow after some period of time, connection is terminated

3 part

- appropriate when there is a relatively continuous flow of data, e.g. voice

- disadvantages:

\rightarrow both stations must be available at same time

\rightarrow resources between stations & networks must be available & dedicated

Message switching:

- station wishing to send message appends a destination address of message is then passed through network from node to node

- at each node, message is received, stored briefly, & then transmitted to next node

4 part

- advantages over circuit switching:

\rightarrow greater line efficiency

\rightarrow no requirement for sender & receiver to be available simultaneously

\rightarrow under heavy traffic, rather than blocked calls (as in circuit), messages still delivered but with greater delay

\rightarrow single message can be sent to many destinations

\rightarrow can establish message priorities

\rightarrow error recovery/control built into networks

Q5 (b) (continued)

12
13

Packet Switching:

- attempts to combine advantages of both circuit of message switching
- main difference from message switching is that length of data units is limited in packet switching
- networks can handle stream of packets either by:

3 part

(i) datagram

- each packet treated independently
- packets can be delivered out of order, it's up to destination node to figure out reordering

(ii) virtual circuit:

- logical connection is established before packets sent
- orig. sends call request to dest. node, which sends accept packet back to orig.
- both terminals can then exchange data over the logical connection
- eventually, one station terminates connection

10

(c) WANs:

(5 part)

- cover large geographical region, relying on circuits provided by a common carrier
- transmission from station is routed through internal switching nodes to destination
- traditionally implemented using circuit switching or packet switching

LANs:

- confined to small area
- traditionally makes use of broadcast network, whereby transmission from a station is broadcast to & received by all other stations
- distinctions from WANs:
 - smaller geographical scope
 - owned by same organization
 - internal data rates much greater
- topologies used are ring, bus, tree & star
- since only one device can successfully transmit at a time, important requirement is for media access control
 - centralized scheme uses single controller to grant access to network; station must wait until permission is received from controller
 - decentralized scheme: stations collectively perform MAC function to dynamically determine order in which stations transmit

(5 part)