

Paper Number(s): E2.3

IMPERIAL COLLEGE OF SCIENCE, TECHNOLOGY AND MEDICINE
UNIVERSITY OF LONDON

DEPARTMENT OF ELECTRICAL AND ELECTRONIC ENGINEERING
EXAMINATIONS 2001

EEE PART II: M.Eng., B.Eng. and ACGI

POWER, FIELDS AND DEVICES

Monday, 18 June 2:00 pm

There are NINE questions on this paper.

There are three sections. Answer FIVE questions including at least ONE question from each of sections A, B and C.

Use a separate answer book for each section.

Time allowed: 3:00 hours

corrected
copy

Examiners: Green, T.C., Holmes, A.S., Leaver, K.D.,
Juhasz, C., Leaver, K.D. and Juhasz, C.

Information for Candidates

Maxwell's equations:

$$\nabla \cdot \mathbf{D} = \rho \quad ; \quad \mathbf{D} = \epsilon \mathbf{E}$$

$$\nabla \cdot \mathbf{B} = 0 \quad ; \quad \mathbf{B} = \mu \mathbf{H}$$

$$\nabla \times \mathbf{E} = -\frac{\partial \mathbf{B}}{\partial t}$$

$$\nabla \times \mathbf{H} = \mathbf{J} + \frac{\partial \mathbf{D}}{\partial t}$$

Physical constants and material parameters:

$$\epsilon_0 = 8.854 \times 10^{-12} \text{ F/m}$$

$$\mu_0 = 4\pi \times 10^{-7} \text{ H/m}$$

$$e = 1.602 \times 10^{-19} \text{ C}$$

$$kT = 0.025 \text{ eV at } 290 \text{ K}$$

$$\text{In SiO}_2 \quad \epsilon = 4 \epsilon_0$$

$$\text{In silicon } \epsilon = 11.7 \epsilon_0$$

Section A

Use a separate answer book for each section

1. (a) Sketch the shape of the torque versus speed graph of a 3-phase induction machine. Explain in physical terms the shape of the curve at, just above and just below synchronous speed.

[5]

- (b) A 3-phase induction machine is connected to a 400 V 50 Hz supply. It has equivalent circuit parameters as follows:

Referred Number of pole-pairs, $P = 2$;
Stator resistance, $R_S = 0.1 \Omega$;
Referred Rotor resistance, $R_R = 0.1 \Omega$;
Magnetising reactance, $X_M = 10 \Omega$;
Magnetising loss resistance, $R_M = 20 \Omega$;
Stator leakage reactance, $X_S = 0.5 \Omega$;
Referred Rotor leakage reactance, $X_R = 0.5 \Omega$;

- (i) Calculate the impedance of the machine for a slip of 0.04

[4]

- (ii) Calculate the stator current

[2]

- (iii) Calculate the rotor current

[3]

- (iv) Calculate the torque developed

[3]

- (v) Calculate the efficiency of the machine.

[3]

2. (a) Sketch the cross-section of a 3-phase generator and describe its features. Comment on the features of the construction that ensure that the generated voltage is sinusoidal. [7]
- (b) Three impedances of $8+j3 \Omega$ are connected in star configuration to a 400 V, 3-phase, 50 Hz supply.
- (i) Calculate the phase current [3]
- (ii) Calculate the real power consumed [2]
- (c) The load in part (b) is found to be unbalanced. One impedance is 5% greater than stated and one is 5% less. Calculate the current that flows in the neutral line. [5]
- (d) The unbalanced impedances of part (c) are reconnected into delta. Calculate one of the line currents [3]

3. (a) Explain why a switch-mode power supply, SMPS is more efficient than a linear voltage regulator. [2]
- (b) Sketch the circuits of both a buck and a boost SMPS. Sketch the shape of the current that flows in the inductor, diode and capacitor for each circuit assuming the inductor to be in continuous conduction mode. [8]
- (c) A boost converter is required to convert 5 V to 12 V. The capacitor has an effective series resistance (ESR) of $30\text{ m}\Omega$ and has a capacitance that can be considered very large. The inductor has a value of $500\text{ }\mu\text{H}$. The switching transistor is operated at 25 kHz.
- (i) Calculate the required duty-cycle. [2]
- (ii) Calculate the ripple of the inductor current. [2]
- (iii) Assuming continuous conduction, determine average value of inductor current when the output current is 5 A [2]
- (iv) Determine whether the circuit is in fact in continuous conduction mode. [2]
- (v) Calculate the output voltage ripple. [2]

Section B

Use a separate answer book for each section

4. (a) Using the appropriate Maxwell equation, together with the definition of electric field as the negative gradient of potential, show that the electrostatic potential in a dielectric medium of constant permittivity satisfies Laplace's equation ($\nabla^2 V = 0$). [4]
- (b) At the interface between a dielectric and a perfect conductor, the electric field on the dielectric side is normal to the conductor surface. Under what conditions will this also be true for a conductor with finite resistance? [2]
- (c) The figure below shows a length of coaxial transmission line. The line is shorted at the left-hand end by a conducting disk, and a constant potential difference V_0 is applied between the centre and outer conductors at the right-hand end. The inner conductor has finite resistance, but the outer conductor and the shorting disk may be assumed to be perfect conductors.

It is suggested that the potential V in the dielectric should vary as:

$$V = V_0 \frac{z \ln(b/r)}{L \ln(b/a)}$$

where L is the length of the line, a and b are radii of the inner and outer conductors, and $r = (x^2 + y^2)^{1/2}$ is the radial distance from the z -axis.

Show that the above potential function is a solution of Laplace's equation, and that it satisfies the required boundary conditions on all conductor surfaces. [8]

Draw a longitudinal section showing electric field lines and equipotentials. You may neglect fringing effects at the open end. [6]

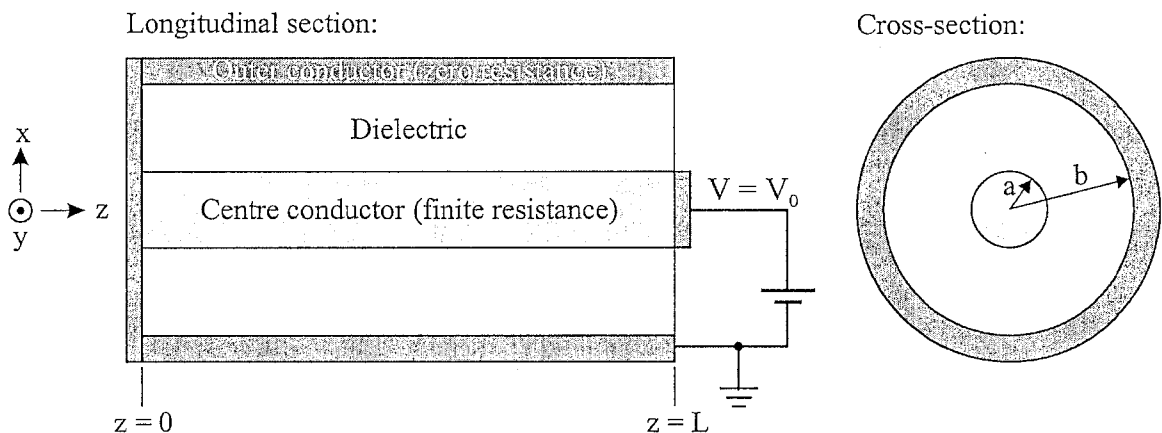

5. The electric field of a particular electromagnetic wave propagating in a highly conducting metal is given by:

$$\mathbf{E}(\mathbf{r}, t) = E_0 \hat{\mathbf{x}} \exp \{j(\omega t - \tau z)\}$$

$$\text{with } \tau = \frac{1-j}{\delta} \quad \text{and} \quad \delta = \sqrt{\frac{2}{\omega \mu \sigma}}.$$

Here ω is the radian frequency of the wave, E_0 is the electric field amplitude at $z = 0$, and μ and σ are the permeability and conductivity of the metal.

- (a) State the directions of propagation and polarization of the wave, and determine its phase velocity. What is the physical significance of δ ? [6]
- (b) Using a suitable Maxwell equation, derive an expression for the magnetic field vector, and hence show that the intrinsic impedance of the metal is:

$$\eta_m = (1 + j) \sqrt{\frac{\omega \mu}{2\sigma}} \quad [8]$$

- (c) A 100 MHz plane electromagnetic wave, travelling in air, is incident normally on a plane copper surface. Estimate the fraction of the power in the wave that is transmitted into the metal. The conductivity of copper is $5.8 \times 10^7 \Omega^{-1}\text{m}^{-1}$, and the impedance of free space is 377Ω . [6]

6. The figure below shows a twin-wire transmission line, comprising two cylindrical conductors of radius a . The conductor axes are separated by a distance $2d$, and the surrounding dielectric medium has permittivity ϵ and permeability μ .

Twin-wire transmission line:

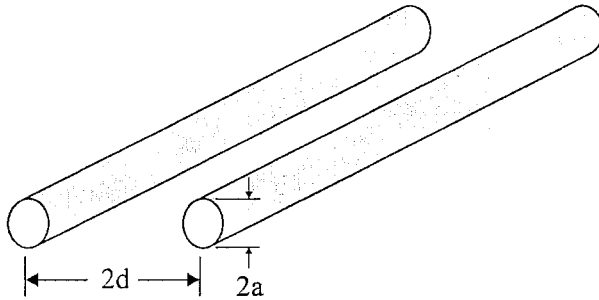

Cross-section:

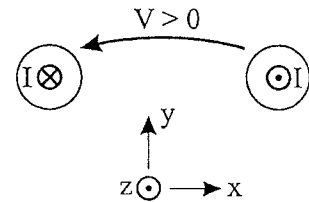

- (a) The cross-section on the right shows a snapshot of the current direction and voltage polarity for a particular TEM wave travelling along the line. Redraw this cross-section, adding lines of electric and magnetic field. In what direction is the wave travelling, and what is its speed of propagation? [6]
- (b) The capacitance C per unit length of the line in part (a) is:

$$C = \frac{\pi\epsilon}{\cosh^{-1}(d/a)}$$

Derive an expression for the characteristic impedance of the line in terms of C and the speed of propagation. Hence determine the minimum achievable impedance with air as the dielectric. [6]

- (c) Explain briefly the principles underlying the method of images. [4]

The twin-wire line of part (a) is transformed to a single-wire line by replacing one of the conductors with a ground plane. The distance from the axis of the remaining conductor to this plane is d . What is the characteristic impedance of the new line? Justify your answer. [4]

Section C

Use a separate answer book for each section

7. (a) Explain briefly what is meant by *channel length modulation*, and give, with reasons, the range of values of transistor voltages over which it occurs.

The SPICE model of channel length modulation is:

$$I_D = I_{DSS}(1 + \Lambda V_{DS})$$

where I_{DSS} and Λ are constants. Show that this is identical to the assumption that the length that is pinched-off varies inversely as $(1 + (\Lambda V_{DS})^{-1})$.

Why does the SPICE model include the factor $(1 + \Lambda V_{DS})$ in voltage ranges in which channel length modulation does *not* occur?

How is the Early voltage V_A related to the SPICE parameters?

[13]

- (b) A single-stage common-source integrated nMOS amplifier is designed to give a voltage gain of 20. The change in g_m with respect to gate voltage for MOSFETs in the chip is 0.03 S/V, their gate length is 0.7 μm , and their overlap capacitance is due to a physical overlap of 0.05 μm length.

Find the input capacitance of the MOSFET amplifier in this circuit, assuming that the mobility of electrons is 0.08 m^2/Vs in the channel.

[7]

8. (a) State the dependence on bias voltage of both the junction and diffusion capacitances of an ideal abrupt p-n diode. Hence show why in normal use one of these can usually be neglected compared to the other. You may assume the following equation:

$$W_n + W_p = \left[\left(\frac{2\epsilon_{Si}(V_o - V)}{e} \right) \right] \left(\frac{1}{N_D} + \frac{1}{N_A} \right)^{1/2}$$

In the circuit of Fig. 8 a photodiode integrated with an amplifier is used to detect pulses of light having a negligible risetime.

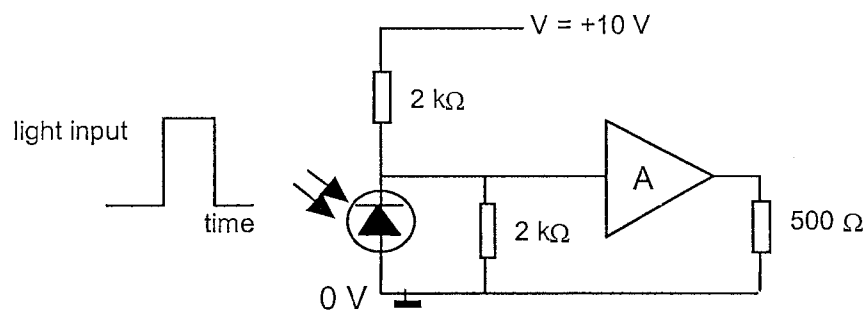

Figure 8

Draw an AC equivalent circuit, assuming an ideal amplifier, and calculate the capacitance of the diode needed to ensure a 3dB bandwidth of 100MHz.

Photodiodes are available with capacitances specified at zero bias of 2.5 pF, 4.0 pF and 10 pF. Which, if any, of these would give the required bandwidth, assuming they each have a grading constant of 1/2, and a built-in voltage of 0.9 V?

[12]

- (b) A junction diode has a reverse current of 3×10^{-7} A at -22 V bias, and is connected in parallel with a 2 kΩ resistor.

Calculate the value of the shot and thermal noise source strengths at room temperature in the frequency band between 100 MHz and 120 MHz, when the total quiescent current through the two components is 1.5 mA, both :

- (1) in the diode's forward direction, and
- (2) in the diode's reverse direction.

You may ignore flicker noise.

[8]

9. The equation

$$\frac{dQ}{dt} = -\frac{Q}{\tau} + I_B$$

describes the transient behaviour of a bipolar transistor when biased in the active region in the circuit of *Figure 9*.

(a) Explain briefly where the charge Q is stored.

What equivalent circuit components relate to the quantity τ , and what physical quantities determine its value?

Explain carefully why the base current and not the emitter or collector current appears in the above equation. [10]

(b) The voltage source in *Figure 9* is switched instantaneously from a positive value V_1 to a negative value $-V_2$ at time $t = 0$. Both V_1 and V_2 are much greater than 0.7 V.

Describe briefly *two* physical mechanisms that cause Q to decrease.

Sketch a graph of the dependence of the charge Q on time t , indicating on it the time at which the *collector* current reaches zero.

Show clearly the features on your graph which are related to τ , and V_1 and V_2 . [7]

(c) Explain how the transistor turn-off time is affected by the values of V_1 and V_2 . [3]

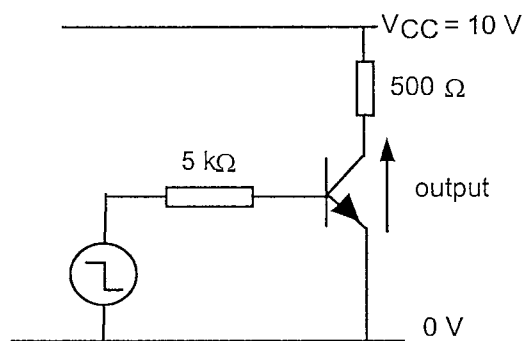

Figure 9

Sec A E2.3 2001
final copy (July 01) (14 pages in total -
8 : 6)

Answers

Section A - POWER

Use a separate answer book for each section

- 1) (a) Sketch the shape of the torque versus speed graph of a 3-phase induction machine. Explain in physical terms the shape of the curve at, just above and just below synchronous speed.

[5]

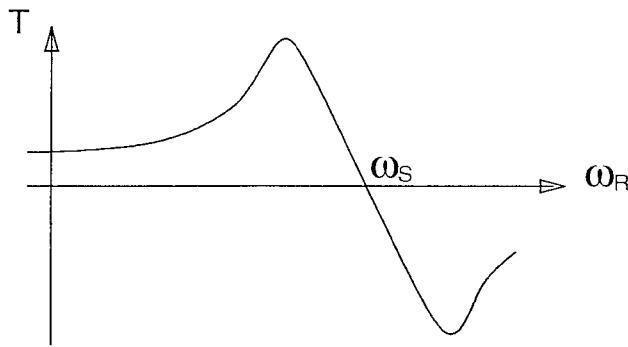

At synchronous speed, the rotor bars rotate at the same speed as the magnetic field and so there is no change of flux linked with the bars; no induced EMF; no rotor current and no torque developed.

As the speed is decreased below synchronous speed, the rate of change of flux linkage increases in proportion; a proportionate current flows and a proportionate torque is developed. This holds until the frequency of the rotor voltage is such that the rotor becomes inductance dominated.

Above synchronous speed, a similar proportionate increase in torque is produced but the torque acts to decrease the speed.

- (b) A 3-phase induction machine has equivalent circuit parameters as follow and is connected to a 400 V 50 Hz supply.

Number of pole-pairs, $P = 2$;
Stator resistance, $R_S = 0.1 \Omega$;
Referred Rotor resistance, $R_R = 0.1 \Omega$;
Magnetising reactance, $X_M = 10 \Omega$;
Magnetising loss resistance, $R_M = 20 \Omega$;
Stator leakage reactance, $X_S = 0.5 \Omega$;
Referred Rotor leakage reactance, $X_R = 0.5 \Omega$;

- (i) Calculate the impedance of the machine for a slip of 0.04

[4]

$$\begin{aligned}
Z_S &= R_S + jX_S \\
Z_R &= \frac{R_R}{s} + jX_R \\
Z_M &= R_M // jX_M \\
Z_T &= Z_S + Z_R // Z_M \\
&= 2.07 + j1.30 \Omega \\
&= 2.45 \angle +32.2^\circ \Omega
\end{aligned}$$

(ii) Calculate the stator current

[2]

$$\begin{aligned}
V_S &= \frac{1}{\sqrt{3}} V_L \\
I_S &= \frac{V_S}{Z_T} \\
&= 94.3 \angle -32.2^\circ \text{ A}
\end{aligned}$$

(iii) Calculate the rotor current

[3]

$$\begin{aligned}
I_R &= I_S \frac{Z_M}{Z_R + Z_M} \\
&= 78.8 \angle -21.3^\circ \text{ A}
\end{aligned}$$

(iv) Calculate the torque developed

[3]

$$\begin{aligned}
P_{Mech} &= 3I_R^2 R_R \left(\frac{1}{s} - 1 \right) \\
&= 44.7 \text{ kW} \\
\omega_R &= (1-s) \frac{\omega_E}{P} \\
&= 150.8 \text{ rad/s} \\
T &= \frac{P_{Mech}}{\omega_R} = 296.5 \text{ Nm}
\end{aligned}$$

(v) Calculate the efficiency of the machine.

[3]

$$\begin{aligned}
P_{in} &= 3 \operatorname{Re} \{ V_S I_S^* \} \\
&= 55.3 \text{ kW} \\
\eta &= \frac{P_{Mech}}{P_{in}} \\
&= 80.1 \%
\end{aligned}$$

- 2) (a) Sketch the cross-section of a 3-phase generator and describe its features. Comment on the features of the construction that ensure that the generated voltage is sinusoidal.

[7]

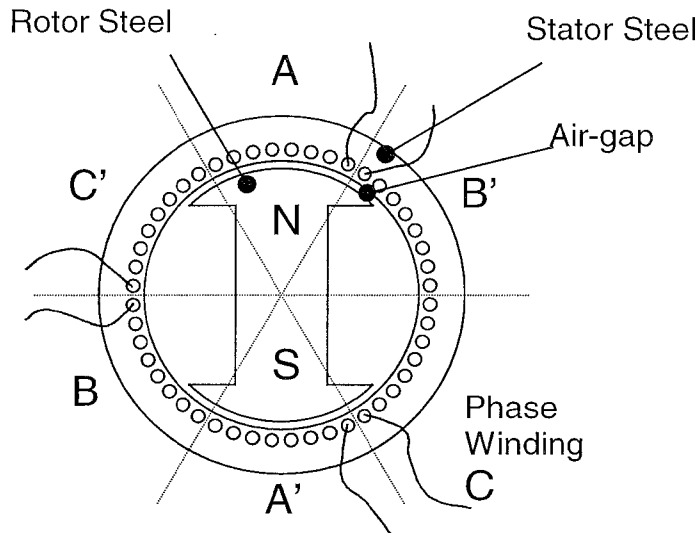

- The machine is constructed from laminated steel compressed into stacks.
 - The stator stack has slots in the inside surface that carry the coils in which the EMF will be generated
 - The coils are distributed around the whole circumference but grouped into phase windings
 - The rotor carries a winding of DC current or a permanent magnet
 - The stator and rotor are separated by an air-gap that is kept as small as practicable
 - The air-gap field is radial and uniform under each rotor pole
 - The induced EMF in a coil is trapezoidal
 - By connecting several adjacent coils in series, a voltage is created that is a staircase approximation to a sinewave and is free of low-order harmonic distortion
- (b) Three impedances of $8+j3 \Omega$ are connected in star configuration to a 400 V, 3-phase, 50 Hz supply.

- (i) Calculate the phase current

[3]

$$V_P = \frac{1}{\sqrt{3}} V_L$$

$$= 230.9 \text{ V}$$

$$I_P = \frac{V_P}{Z}$$

$$= 25.3 - j9.5 \text{ A}$$

$$= 27.0 \angle -20.55^\circ \text{ A}$$

- (ii) Calculate the real power consumed

$$\begin{aligned}
 P &= 3V_P I_P \cos(\phi) \\
 &= 3 \operatorname{Re}\{V_P I_P^*\} \\
 &= 17.5 \text{ kW}
 \end{aligned}
 \tag{2}$$

- (c) The load in part (b) is found to be unbalanced. One impedance is 5% greater than stated and one is 5% less. Calculate the current that flows in the neutral line.

Different angles of neutral current will result from different arrangements of the impedances. One example is given here.

$$I_A = 25.3 - j9.5 \text{ A}$$

$$\begin{aligned}
 I_B &= \frac{V_P \angle -120^\circ}{1.05 \times Z} \\
 &= -19.9 - j16.3 \text{ A}
 \end{aligned}$$

$$\begin{aligned}
 I_C &= \frac{V_P \angle +120^\circ}{0.95 \times Z} \\
 &= -4.7 + j28.1 \text{ A}
 \end{aligned}$$

$$\begin{aligned}
 I_N &= -I_A - I_B - I_C \\
 &= -0.8 - j2.2 \text{ A} \\
 &= 2.3 \angle -109^\circ
 \end{aligned}$$

Different angles of neutral current will result from different arrangements of the impedances.

- (d) The unbalanced impedances of part (c) are reconnected into delta. Calculate one of the line currents

Three possible answers given here:

$$V_{AB} = 400 \angle 0^\circ \text{ V}$$

$$V_{BC} = 400 \angle -120^\circ \text{ V}$$

$$V_{CA} = 400 \angle 120^\circ \text{ V}$$

$$\begin{aligned}
 I_{AC} &= \frac{V_{AB}}{Z} \\
 &= 43.8 - j16.4 \text{ A}
 \end{aligned}$$

$$\begin{aligned}
 I_{BC} &= \frac{V_{BC}}{1.05 \times Z} \\
 &= -34.4 - j28.3 \text{ A}
 \end{aligned}$$

$$\begin{aligned}
 I_{CA} &= \frac{V_{CA}}{0.95 \times Z} \\
 &= -8.1 + j48.6 \text{ A}
 \end{aligned}$$

$$\begin{aligned} I_A &= I_{AB} - I_{CA} \\ &= 51.9 - 65.1 A \\ &= 83.2 \angle -51.4^\circ A \end{aligned}$$

$$\begin{aligned} I_B &= I_{BC} - I_{AB} \\ &= -78.2 - 11.9 A \\ &= 79.2 \angle -171.4^\circ A \end{aligned}$$

$$\begin{aligned} I_C &= I_{CA} - I_{BC} \\ &= 26.3 + 76.9 A \\ &= 81.3 \angle +71.1^\circ A \end{aligned}$$

- 3) (a) Explain why a switch-mode power supply, SMPS is more efficient than a linear voltage regulator. [2]

A switch-mode power supply uses a transistor in two states, fully on (e.g. ohmic region of a MOSFET) or fully off. The transistor only traverses the active region briefly between these two states. Thus a coincidence of voltage across the transistor and current through it are avoided and power dissipation is low.

A linear regulator uses a transistor to "drop" voltage between input and output and thus there is voltage across it while it carries current. The transistor is in its active region and dissipates considerable power.

- (b) Sketch the circuits of both a buck and a boost SMPS. Sketch the shape of the current that flows in the inductor, diode and capacitor for each circuit assuming the inductor to be in continuous conduction. [8]

Buck

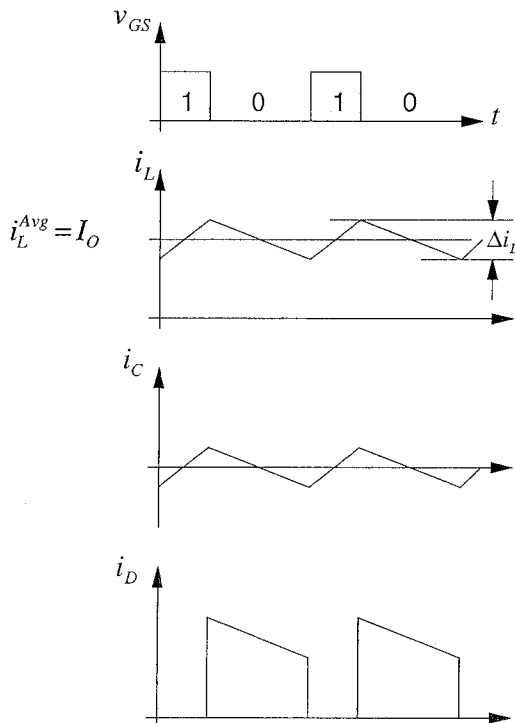
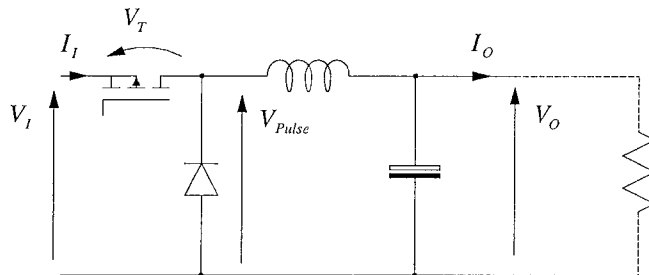

Boost

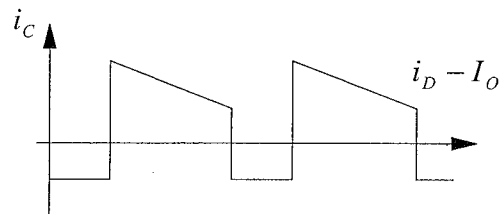
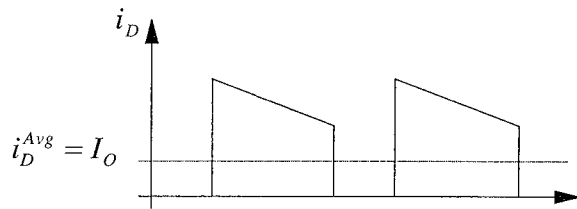
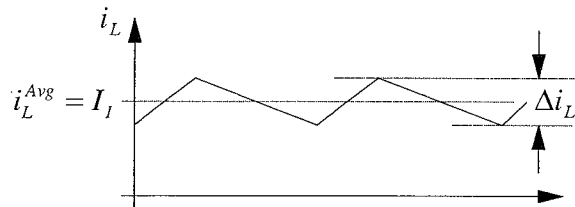
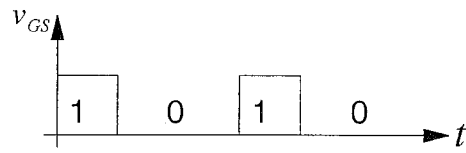
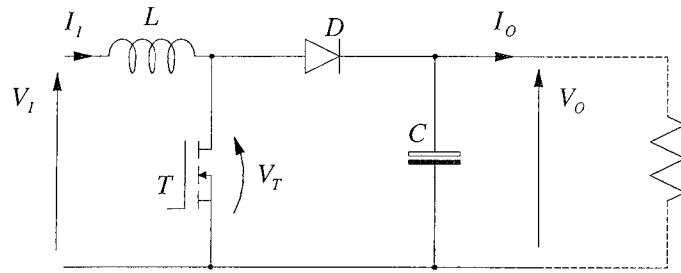

(c) A boost converter is required to convert 5 V to 12 V. The capacitor is large valued and has an effective series resistance, ESR of 30 mΩ. The inductor is 500 μH. The switching transistor is operated at 25 kHz.

(i) Calculate the required duty-cycle.

[2]

$$\begin{aligned}\frac{V_o}{V_i} &= \frac{1}{1-\delta} \\ \delta &= \frac{V_o - V_i}{V_o} \\ &= 0.58333\end{aligned}$$

(ii) Calculate the ripple of the inductor current.

[2]

$$\begin{aligned}\Delta i_L &= \frac{V_i}{L} \times \frac{\delta}{f} \\ &= 0.2333 \text{ A}\end{aligned}$$

(iii) Assuming continuous conduction, determine average value of inductor current when the output current is 5 A

[3]

$$\begin{aligned}i_D^{Avg} &= I_o \\ i_D^{Avg} &= i_L^{Avg} (1-\delta) \\ i_L^{Avg} &= \frac{I_o}{(1-\delta)} \\ &= 12 \text{ A}\end{aligned}$$

(iv) Determine whether the circuit is in fact in continuous conduction.

[1]

$$i_L^{Avg} > \frac{1}{2} \Delta i_L \text{ therefore the inductor current is continuous}$$

(v) Calculate the output voltage ripple.

[2]

$$\begin{aligned}i_C^{pp} &= i_D^{pp} \\ &= i_L^{Avg} + \frac{1}{2} \Delta i_L \\ &= 12.12 \text{ A} \\ v_O^{pp} &= i_C^{pp} R_{ESR} \\ &= 364 \text{ mV}\end{aligned}$$

4 (a) Maxwell I: $\nabla \cdot \underline{D} = \nabla \cdot (\epsilon \underline{E}) = \rho$

In a dielectric where $\epsilon = \text{const.}$ and $\rho = 0$ this becomes $\nabla \cdot \underline{E} = 0$ and, since $\underline{E} = -\nabla V$, we have

$$\nabla \cdot (\nabla V) = 0 \quad \text{or} \quad \nabla^2 V = 0 \quad [4]$$

(b) For perfect conductor, $\underline{E} = 0$ inside, and continuity of E_{\parallel} at boundary gives $E_{\parallel} = 0$ outside.

For real conductor, still have continuity of E_{\parallel} , but $\underline{E} = 0$ inside only if no current [2]

[Otherwise $E_{\parallel \text{ outside}} = \frac{J}{\sigma}$ where J is current density at conductor surface.]

(c) Need to show $\frac{\partial^2 V}{\partial x^2} + \frac{\partial^2 V}{\partial y^2} + \frac{\partial^2 V}{\partial z^2} = 0$ for $V = z \ln(b/r)$

$$\frac{\partial V}{\partial x} = -\frac{z}{r} \frac{\partial r}{\partial x} = -\frac{xz}{r^2} \quad \frac{\partial^2 V}{\partial x^2} = -\frac{z}{r^2} + \frac{2xz^2}{r^4} \quad (\text{used } \frac{\partial r}{\partial x} = \frac{x}{r})$$

$$\text{symmetry} \Rightarrow \frac{\partial^2 V}{\partial y^2} = -\frac{z}{r^2} + \frac{2yz^2}{r^4}$$

$$\Rightarrow \frac{\partial^2 V}{\partial x^2} + \frac{\partial^2 V}{\partial y^2} = -\frac{2z}{r^2} + \frac{2xz^2}{r^4} + \frac{2yz^2}{r^4} = 0 \quad (x^2 + y^2 = r^2)$$

Also, $\frac{\partial V}{\partial z} = \ln(b/r)$, $\frac{\partial^2 V}{\partial z^2} = 0 \Rightarrow \nabla^2 V = 0$ as req'd.

B.C.s When $r=b$, $V=0$ ✓ since outer (perfect) conductor is grounded.

When $z=0$, $V=0$ ✓

When $r=a$, $V = \frac{V_0 z}{L}$ ✓ uniform \underline{E} field with $E = \frac{V_0}{L}$ in inner (real) conductor [8]

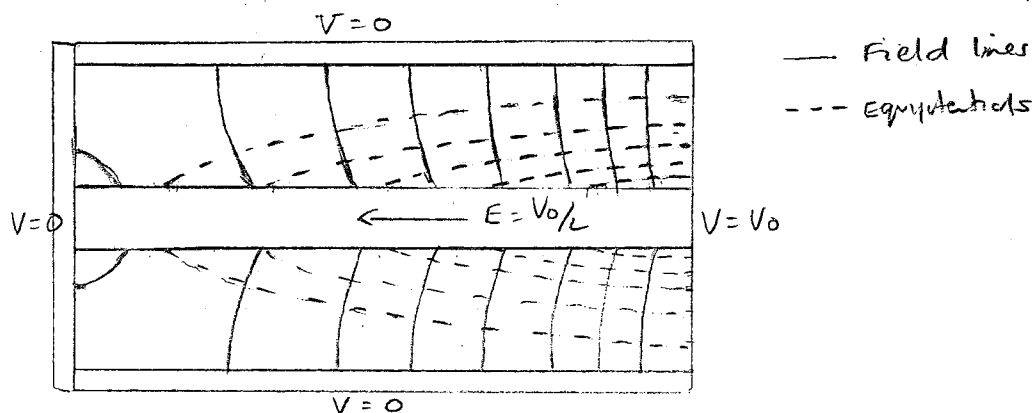

NB. my sketch could be better!

$$5 \text{ (a)} \quad \underline{E} = E_0 \hat{x} \exp j(\omega t - \frac{z}{\delta} + \frac{jz}{\delta}) = E_0 \hat{x} e^{-z/\delta} e^{j(\omega t - z/\delta)}$$

Wave is x-polarized, and propagates in +z dirn

Phase velocity? $\phi = \omega t - z/\delta = \text{const.} \Rightarrow z = \omega t + \text{const.}$

$$\text{So } v_p = \omega \delta$$

δ = skin depth; depth at which amplitude of EM wave entering conductor falls to $1/e$ x amplitude at surface. [6]

(b) Using $\nabla \times \underline{E} = -\dot{\underline{B}}$:

$$\nabla \times \underline{E} = \begin{vmatrix} \hat{x} & \hat{y} & \hat{z} \\ \frac{\partial}{\partial x} & \frac{\partial}{\partial y} & \frac{\partial}{\partial z} \\ E_x & 0 & 0 \end{vmatrix} = \begin{pmatrix} 0 & \frac{\partial E_x}{\partial z} & -\frac{\partial E_x}{\partial y} \\ = 0 & = -\mu \frac{\partial H}{\partial t} \end{pmatrix} = (0, -j\omega E_x, 0)$$

$$\text{So } \underline{H} = (0, H_y, 0) \text{ with } -\mu \frac{\partial H_y}{\partial t} = -j\omega E_x$$

$$\text{Integrating wrt time } \Rightarrow -\mu H_y = \frac{-j\omega E_x}{j\omega}$$

$$\text{Given } H_y = \frac{\tau E_x}{\mu \omega}$$

$$\text{Asker for } \underline{H} \text{ vector, so: } \underline{H} = \frac{\tau E_0}{\mu \omega} \hat{y} \exp j(\omega t - \tau z)$$

$$\text{Impedance: } \eta_m = \frac{E_x}{H_y} = \frac{\mu \omega}{\tau} = \frac{\omega \mu \delta}{(1-j)} = \frac{(1+j) \cdot \omega \mu \cdot \sqrt{\frac{2}{\omega \mu \sigma}}}{2} = (1+j) \sqrt{\frac{\omega \mu}{2\sigma}} \quad [8]$$

$$(c) \text{ Amplitude refl. coeff is } \rho = \frac{\eta_m - \eta_0}{\eta_m + \eta_0} \approx -1 + \frac{2\eta_m}{\eta_0} \quad (\eta_m \ll \eta_0)$$

$$\text{Fractn of pwr reflected} = |\rho|^2 = (-1 + \frac{2\eta_m}{\eta_0})(-1 + \frac{2\eta_m^*}{\eta_0}) \approx 1 - \frac{2(\eta_m + \eta_m^*)}{\eta_0}$$

$$\Rightarrow \text{Fractn transmitted} = \frac{2(\eta_m + \eta_m^*)}{\eta_0} = \frac{4 \text{Re}[\eta_m]}{\eta_0} = \frac{4}{\eta_0} \sqrt{\frac{\omega \mu}{2\sigma}}$$

$$\omega = 2\pi \times 10^8, \quad \mu = 4\pi \times 10^{-7}, \quad \sigma = 5.8 \times 10^7, \quad \eta_0 = 377 \Omega$$

$$\Rightarrow \text{Fractn transmitted} = 2.7 \times 10^{-5} = 0.0027\% \quad [6]$$

6 (a)

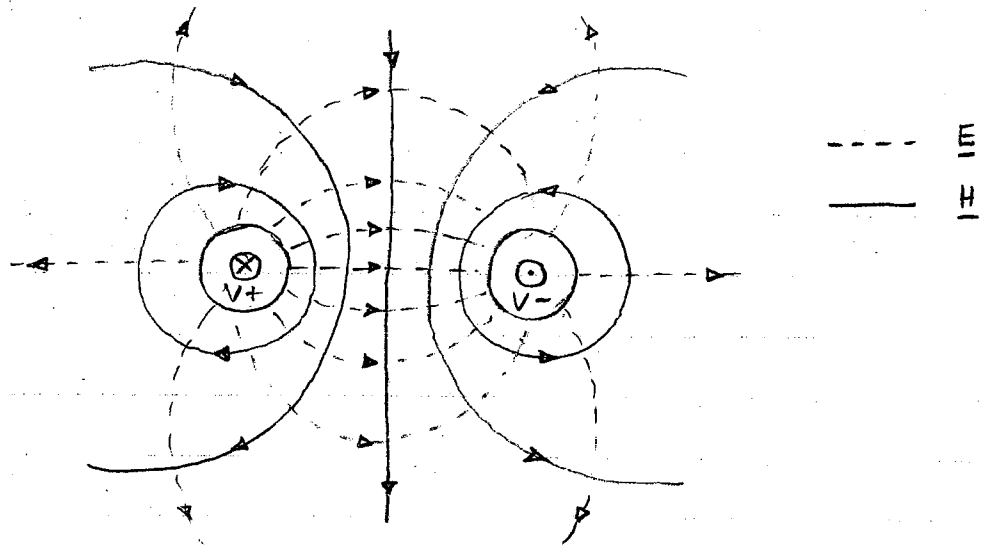

Considering $\underline{E} \times \underline{H}$ eg at mid-point between conductors :

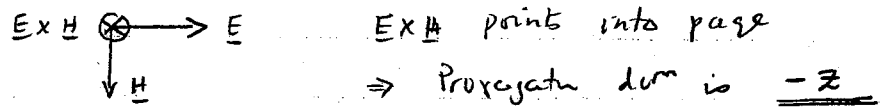

Wave is TEM \Rightarrow Speed of propagation is $v = \frac{1}{\sqrt{\epsilon\mu}}$

[6]

(b) $Z_0 = \sqrt{\frac{L}{C}}$ and $v = \frac{1}{\sqrt{LC}} \Rightarrow Z_0 = \frac{1}{vC}$

So $Z_0 = \sqrt{\epsilon\mu} \cdot \frac{\cosh^{-1}(d/a)}{\pi\epsilon} = \eta \cdot \frac{\cosh^{-1}(d/a)}{\pi}$, $\eta = \sqrt{\frac{\mu}{\epsilon}}$

For air, $\eta = 377 \Omega$ and $d/a \geq 1 \Rightarrow Z_0 \geq 120 \Omega$

[6]

(c) M.O.I : involves finding a distribution of charges that satisfies boundary conditions of problem. Solution is then sum of potentials due to charges. Relies on uniqueness.

[4]

Considering twin-wire line, dotted line is equipotential

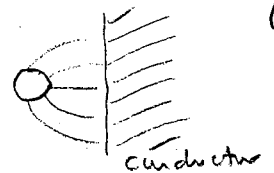
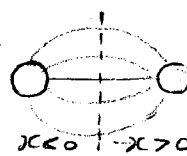

\Rightarrow Region $x > 0$ can be replaced by conductor w/o affecting potential in $x < 0$

Also, for given q per unit length, p.d. between each conductor and mid-line = $\frac{1}{2}$ that between conductors

\Rightarrow For single-wire line $C = 2 \times \frac{\pi\epsilon}{\cosh^{-1}(d/a)}$

[4]

$v = \frac{1}{\sqrt{\mu\epsilon}}$ stay true, so $Z_0 = \eta \frac{\cosh^{-1}(d/a)}{2\pi}$

Section C: Devices: Answers.

7. (a) Channel length modulation: the effect on drain current of the pinch-off occurring at the drain end of the conducting channel when the drain-source voltage rises beyond $V_{GS} - V_T$.

Physicist model:
$$I_{DSS} = \frac{\text{Const}}{L - L_d}$$

where L_d is the pinched-off length.

Setting this equal to given expression,

$$L - L_d = (1 + \lambda V_{DS})^{-1} \text{Const.}$$

i.e.
$$\frac{L_d}{L} = 1 - (1 + \lambda V_{DS})^{-1} = [1 + (\lambda V_{DS})^{-1}]^{-1}$$

SPICE model ensures continuity of the values across the triode and saturation regions, which are modelled by different equations.

Early voltage V_A = value of V_{DS} at which I_D extrapolates to zero: i.e. $\lambda V_A = -1$.

(b)
$$\frac{g_m}{V_{GS} - V_T} = \mu C_{ox} \frac{W}{L} = 0.03 \text{ S}, \text{ So } C_{ox} W L = \frac{0.03 \times 0.49 \times 10^{-12}}{0.08} = 0.184 \text{ pF}$$

And
$$C_{gd} = C_{ox} \times W \times L_{\text{overlap}} = 0.184 \times \frac{0.05}{0.7} \text{ pF} = 0.013 \text{ pF} \quad (\text{Miller capacitance})$$

Hence effective input capacitance =
$$((+A) \times 0.013 + \frac{2}{3} \times 0.184) \text{ pF} = 0.396 \text{ pF.}$$

8. (a) $C_{\text{junction}} \propto \frac{1}{(1 - V/V_0)^{1/2}}$ $V_0 = \text{built-in voltage}$

$C_{\text{diffusion}} \propto I \propto [\exp(V/V_T) - 1]$

Hence in forward bias the latter dominates,
reverse " " former "

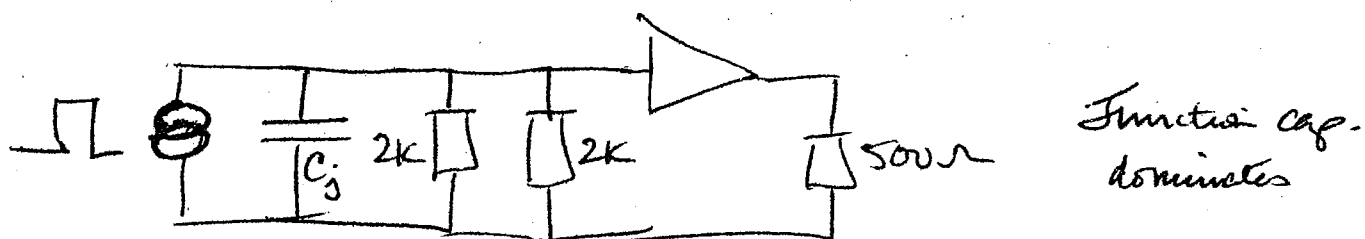

For 100 kHz B/W, $C_j \leq (2\pi \times 10^8 \times 10^3)^{-1} = 1.6 \text{ pF}$

Now $V_{\text{bias}} = -5V$, so zero-bias capacitance C_{j0} must be

$C_{j0} \leq 1.6 \text{ pF} (1 + 5/0.9)^{1/2} = 4.09 \text{ pF}$

Hence only only 2 photodiodes are OK.

(b)

Shot noise current $i_n^2 = 2eIB$ - ideal diodes & junctions

Thermal " " $i_n^2 = 4kTgB$ - resistors

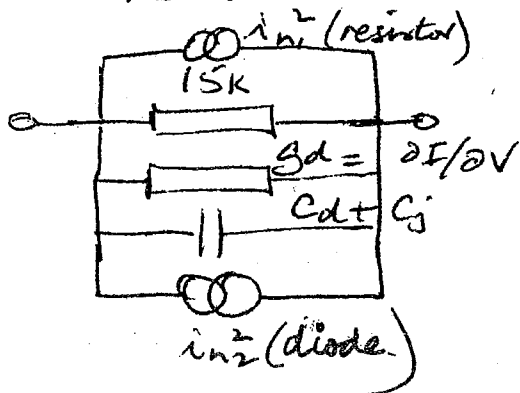

$i_{n1}^2 = \frac{4kT \times 0.2 \times 10^6}{15 \times 10^3} = 2.13 \times 10^{-19}$

case (1) $I = 1.5 \text{ mA}$

$i_{n2}^2 = 2e \times 1.5 \times 10^{-3} \times 0.2 \times 10^6 = 9.6 \times 10^{-17}$

case (2) $I = 4 \times 10^{-7} \text{ A}$

$i_{n2}^2 \approx 4 \times 10^{-7} \times 2e \times 0.2 \times 10^6 = 2.56 \times 10^{-19}$

~~due to 1/frequency, and falls to negligible values at frequencies above a few hundred kHz.~~

9 (a) Q is stored in narrow base region.

τ is either base-emitter equivalent circuit time constant $V_{be} C_{be}$, where $V_{be} = \frac{V_T}{I_B}$ & $C_{be} = \tau_f I_c$

where τ_f is the transit time thro' the base

or τ is $\beta \times \tau_f$, where β is current gain dependent on doping in emitter & base (and recombination in the base ... good students will recall this)

τ_f depends on base width and diffusion coefficient.

Charge Q consists of equal quantities Q of majority & minority carriers. The former can only be removed or injected via the base ^{or emitter} contacts, (because their motion thro' the ^{CB} junction is opposed by the potential across that junction) Hence Q can be extracted by I_B .

(b) Q decreases by (1) removal of majority charge via the base & (2) recombination within the base. (each relates to one of the 2 terms in the equation given)

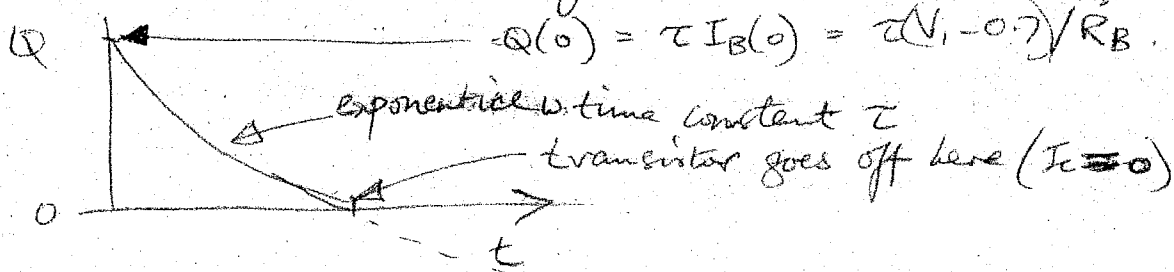

(c) turn-off time (max $Q(0)$) (faster extraction of Q via I_B) - is raised by increasing V_1 and decreased by increasing $|V_2|$.