

Special Information for Invigilators: None

Information for Candidates:

Fundamental constants

Permittivity of free space, $\epsilon_0 = 8.85 \times 10^{-12}$ F/m

Permeability of free space, $\mu_0 = 4\pi \times 10^{-7}$ H/m

Planck's constant, $h = 6.62 \times 10^{-34}$ Js

Boltzmann's constant, $k = 1.38 \times 10^{-23}$ J/K

Electron charge, $e = 1.6 \times 10^{-19}$ C

Electron mass, $m = 9.1 \times 10^{-31}$ kg

Speed of light, $c = 3.0 \times 10^8$ ms⁻¹

Schrödinger's equation

General form:

$$-\frac{\hbar^2}{2m} \nabla^2 \psi(\mathbf{r}) + V(\mathbf{r})\psi(\mathbf{r}) = E\psi(\mathbf{r})$$

In one dimension:

$$-\frac{\hbar^2}{2m} \frac{d^2 \psi(x)}{dx^2} + V(x)\psi(x) = E\psi(x)$$

In spherical coordinates:

$$\nabla^2 = \frac{d^2}{dr^2} + \frac{2}{r} \frac{d}{dr}$$

Free-electron theory

Density of states (3D):

$$g(E) = \frac{1}{\pi^2 \hbar^3} (m)^{3/2} \sqrt{2E}$$

Fermi energy

$$E_f = \frac{\hbar^2 \pi^2}{2m} \left(\frac{3n}{\pi} \right)^{2/3}$$

Fermi distribution

$$f(E) = \frac{1}{1 + \exp\left(\frac{E - E_f}{kT}\right)}$$

Electrons in semiconductors

Effective mass:

$$m_e^* = \frac{\hbar^2}{d^2 E(k)/dk^2}$$

Concentration of electrons in a semiconductor of bandgap E_g :

$$n = \frac{1}{\sqrt{2}\hbar^3} \left(\frac{m_e^* kT}{\pi} \right)^{3/2} e^{-\frac{(E_g - E_f)}{kT}}$$

$$= N_c e^{-\frac{(E_g - E_f)}{kT}}$$

Number density of holes

$$p = \frac{1}{\sqrt{2}\hbar^3} \left(\frac{m_h^* kT}{\pi} \right)^{3/2} e^{-\frac{E_f}{kT}}$$

$$= N_v e^{-\frac{E_f}{kT}}$$

Polarization

Lorentz correction for local field:

$$\mathbf{E}_{loc} = \mathbf{E} + \frac{\mathbf{P}}{3\epsilon_0}$$

Electronic polarization:

$$P_0 = \frac{\epsilon_0 \omega_p^2 E_0}{\omega_m^2 - \omega^2 + j\omega\gamma}$$

where

$$\gamma = \frac{r}{m},$$

$$\omega_m^2 = \omega_0^2 - \frac{\omega_p^2}{3},$$

$$\omega_0^2 = k/m,$$

$$\omega_p^2 = \frac{ne^2}{m\epsilon_0}.$$

Orientalional Polarization:

Static:

$$P = n\mu L(\mu E/kT)$$

where

$$L(x) = \coth(x) - 1/x$$

Dynamic:

$$P_0 = \frac{P_s}{1 + j\omega\tau},$$

Magnetism

Magnet dipole due to electron angular momentum:

$$\boldsymbol{\mu}_m = -\frac{e\mathbf{L}}{2m}$$

Magnet dipole due to electron spin:

$$\boldsymbol{\mu}_m = -\frac{e\mathbf{S}}{m}$$

Paramagnetism:

$$M = n\mu_m L\left(\frac{\mu_m \mu_0 H}{kT}\right)$$

The Questions

1. (a) Figure 1 shows schematically the experimental arrangement for determining the Hall effect of a block of semiconductor. Explain the origin of the Hall Voltage, V_H , if only holes are present in the semiconductor and show that the Hall coefficient, R_H , defined as $R_H = \frac{E_H}{JB}$, where E_H is the Hall field and J is the current density in the semiconductor, is given by $R_H = -\frac{1}{pe}$, where p is the concentration of holes in the semiconductor and $-e$ is the charge of an electron. What is the polarity of the voltage? [8]

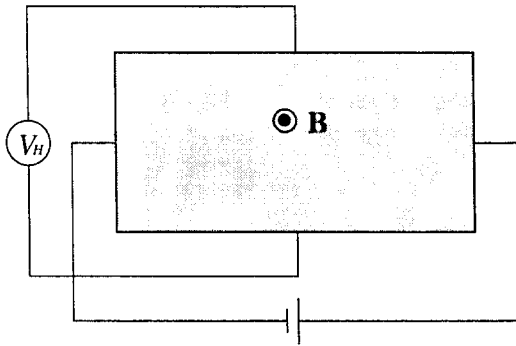

Figure 1: Experimental arrangement for determining the Hall effect, with the magnetic field out of the plane of the paper

- (b) When both electrons and holes are present, the Hall coefficient is given by $R_H = \frac{p\mu_h^2 - n\mu_e^2}{e(p\mu_h + n\mu_e)^2}$ where p is the concentration of conducting holes, n the concentration of conducting electrons, and μ_h and μ_e are the mobilities of the holes and electrons respectively. A block of silicon at room temperature is found to have a zero Hall voltage for all magnetic fields. Determine the concentration and type of doping in the block where the intrinsic carrier concentration $n_i = 1.4 \times 10^{10} \text{ cm}^{-3}$, $\mu_e = 1500 \text{ cm}^2\text{V}^{-1}\text{s}^{-1}$ and $\mu_h = 450 \text{ cm}^2\text{V}^{-1}\text{s}^{-1}$. [8]
- (c) How might the Hall effect be exploited to produce a sensor to measure the strength and direction of a magnetic field? [4]

2. (a) Define:
- (i) electron ground state
 - (ii) effective mass
 - (iii) band gap
- [3]

(b) By solving Schrödinger's equation in radial coordinates for an electron in the coulomb potential of a proton, show that the trial solution $\psi(r) = \psi_0 e^{-r/r_0}$ for the ground state of an electron in a hydrogen atom has an energy, E , given by $E = \frac{me^4}{32\pi^2\epsilon_0^2\hbar^2}$ with

$$r_0 = \frac{4\pi\hbar^2\epsilon_0}{me^2}. \quad [6]$$

(c) Silicon has been doped with donor atoms. Assuming that the donor electron has an effective mass of 0.26 the free mass of an electron and occupies a hydrogenic orbit, but with a coulomb potential modified by the relative dielectric constant of silicon, $\epsilon_r = 12$, show that the donor electron lies 0.025 eV below the conduction band of the silicon. [5]

(d) Hence show that when the Fermi level is near the centre of the bandgap, nearly all the dopants are thermalised at room temperature. The bandgap of silicon is 1.1 eV. [6]

3. (a) Show how Young's modulus, E , of a simple cubic crystal material is related to the atomic bond strength, k , and the atomic spacing r_0 by the relationship $E = k/r_0$ [8]

(b) A bundle of parallel 50 μm -diameter quartz optical fibres (Young's modulus 7×10^{10} Pa, Poisson's ratio 0.17) is manufactured by tightly bonding together the fibres along their lengths. The diameter of the resulting bundle is 0.5 mm. During installation, the bundle is bent into a 90°-curve of radius 2.5 m (fig. 3). Assuming there is no twisting of the bundle and that the individual fibres retain their circular cross sections, calculate the stress in, and the change in the diameter of, fibres (i), (ii) and (iii) in figure 3 where

- i. is on the outside of the curve [8]
- ii. is in the centre of the bundle
- iii. is on the inside of the curve.

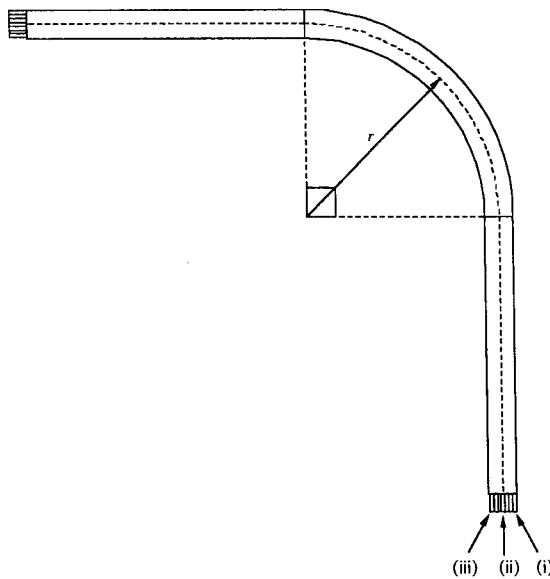

Figure 3: A quartz-fibre bundle bent round a curve of radius r .

(c) The quartz fibres have a yield strength of 10^9 Pa in compression and 10^8 Pa in extension. What would be the expected failure mode? Assuming a safety factor of 10, what should be the minimum radius of curvature allowed for these bundles during installation? [4]

4. (a) Figure 4 shows the variation of the real part of the dielectric constant ϵ_r' , of a material with the frequency of an alternating electric field. Describe the mechanism associated with the changes in ϵ_r' in regions 1, 2 and 3.

What is the value of $\epsilon_r'(\infty)$ and why?

Sketch the corresponding plot for the imaginary component, ϵ_r'' . [7]

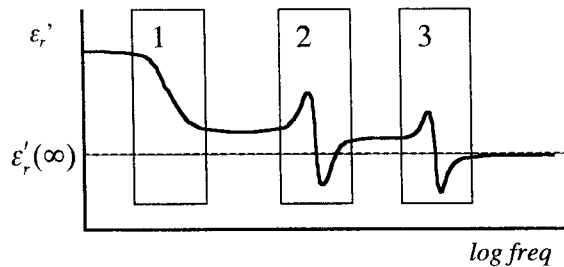

Figure 4: Plot of real part of dielectric constant with frequency

- (b) In region 1 the complex dielectric constant has the general form

$$\epsilon_r(\omega) = \epsilon_{r1} + \frac{\Delta\epsilon_r}{1 + j\omega\tau}$$

An electrolytic capacitor contains a certain dielectric with values ϵ_{r1} of 1.3 and $\Delta\epsilon_r$ of 2.1. The relaxation time, τ , is 1 μ s. What is the fraction of the DC capacitance at excitation frequencies of 100 kHz, 1 MHz and 10 MHz?

What is the loss tangent at 1 MHz?

[9]

- (c) Copy figure 4, and add new curves to show the variation of the real part of the dielectric constant if

- (i) the capacitor is heated above room temperature,
- (ii) the capacitor is cooled sufficiently to freeze the dielectric.

[4]

5. (a) Show that using the Bohr model of the atom, the magnetic dipole μ_m of an electron due to its orbital angular momentum, L , is given by $\mu_m = -\frac{eL}{2m}$ where $-e$ is the charge on an electron, [6]
and m the electron mass.

(b) The density of states for electrons $g(E)$ in the conduction band of a material is shown in figure 5.1. Show (i) graphically and (ii) algebraically the relationship between the density of states and the electron concentration for the material at low temperature.

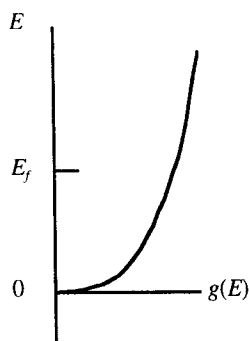

Figure 5.1: Density of states without magnetic field

The material is placed in a magnetic field, H . Figure 5.2 shows the density of states for the spin up $g_{up}(E)$ and spin down $g_{down}(E)$ electrons plotted back-to-back. Explain the changes [8]
from figure 5.1 and hence show that the material is paramagnetic.

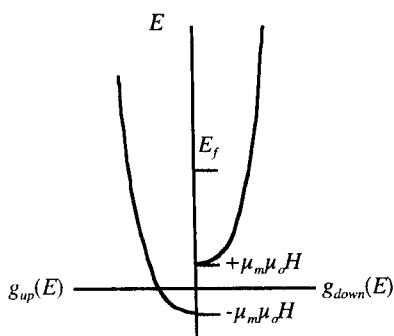

Figure 5.2: Density of states in magnetic field

(c). Show that the magnetic susceptibility for this material at low temperatures is given by

$$\chi_m = \mu_m^2 \mu_0 g(E_f) \quad [6]$$

You may assume that $\mu_m \mu_0 H \ll E_f$

Electronic Materials 1.5

2004

Answers

1. a. The battery produces flow of holes through the block of semiconductor. The moving holes experience a transverse force of magnitude Bev , where v is the drift velocity of the holes. By the right-hand rule, the force on the positively charged holes will be vertically upwards, causing an accumulation of positive charge on the top surface and a corresponding depletion of holes and hence negative charge on the bottom surface. This will produce the Hall field that will build up until the opposed electric and magnetic transverse forces on the holes are equal and opposite, and no overall vertical movement of the holes occurs. A corresponding constant Hall voltage will then be produced with the top surface positively biased with respect to the bottom surface of the semiconductor. [4]

The resulting condition:

$$Bev = eE_H \quad [1]$$

implies

$$E_H = Bv$$

From the expression for the current density:

$$J = pev$$

we obtain

$$E_H = \frac{BJ}{pe} \quad [1]$$

and so from the definition of the Hall coefficient:

$$|R_H| = \frac{E_H}{BJ} = \frac{1}{pe} \quad [1]$$

Polarity ; see above. (*bookwork*) [1]

b. If $R_H = 0$ then $p\mu_h^2 - n\mu_e^2 = 0$ [1]

Hence

$$\frac{p}{n} = \left(\frac{\mu_e}{\mu_h} \right)^2 \quad [1]$$

As from the law of mass action,

$$np = n_i^2 \quad [1]$$

combining

$$n = n_i \frac{\mu_h}{\mu_e},$$

$$p = n_i \frac{\mu_e}{\mu_h} \quad [1]$$

As $\mu_h < \mu_e, p > n_i$, and so the doping is p-type. At room temperature, the dopants will be completely thermalised, and [2]

$$\begin{aligned}
 N_A = p &= n_i \frac{\mu_e}{\mu_h} \\
 &= 1.4 \times 10^{10} \frac{1500}{450} \quad (\text{new theory and calculation}) \\
 &= 4.7 \times 10^{10} \text{ cm}^{-3}
 \end{aligned}$$

[2]

(c) To measure a component of the magnetic field, a constant current should be driven through a block of material, in the geometry shown in figure 1, and the Hall voltage measured. A battery, preferably driving a constant current source, will provide the current. An opamp can be used on the output to increase the relatively small Hall voltage to reasonable levels. [2]

Three orthogonally mounted blocks can be used to measure the three components. Alternatively, if contacts are made on the two pairs of faces perpendicular to the current flow, a two-axis sensor can be produced, and two of these combined to make a three-axis sensor, with an axis duplicated for calibration and healthchecking. (*new application*) [2]

2. a) i. The electron ground state is the lowest energy wavefunction available for a particular potential.

ii. The effective mass is the apparent mass of the electron in a solid

iii. a band gap is a range of energies in a material where no electron states exist. (bookwork) [3]

b) The potential energy due to a proton will be

$$V(r) = \frac{-e^2}{4\pi\epsilon_0 r} \quad [1]$$

so the equation to solve is

$$-\frac{\hbar^2}{2m} \left(\frac{d^2\psi(r)}{dr^2} + \frac{2}{r} \frac{d\psi(r)}{dr} \right) - \frac{e^2}{4\pi\epsilon_0 r} \psi(r) = E\psi(r) \quad [1]$$

Substituting in the trial solution

$$\psi(r) = \psi_0 e^{-r/r_0}$$

gives

$$-\frac{\hbar^2}{2m} \left\{ \frac{e^{-r/r_0}}{r_0^2} + \frac{2}{r} \left(-\frac{e^{-r/r_0}}{r_0} \right) \right\} - \frac{e^2}{4\pi\epsilon_0 r} e^{-r/r_0} = E e^{-r/r_0} \quad [1]$$

Coefficients of e^{-r/r_0} and $\frac{e^{-r/r_0}}{r}$ produce two simultaneous equations to be solved:

$$-\frac{\hbar^2}{2mr_0^2} = E$$

$$\frac{\hbar^2}{mr_0} - \frac{e^2}{4\pi\epsilon_0} = 0 \quad [1]$$

Solving the second equation:

$$r_0 = \frac{4\pi\epsilon_0 \hbar^2}{me^2} \quad [1]$$

and substituting into the first:

$$E = -\frac{me^4}{32\pi^2\epsilon_0^2\hbar^2} \quad [1]$$

(bookwork)

c) The electron of the dopant atom sees the potential reduced to

$$V(r) = \frac{-e^2}{4\pi\epsilon_r\epsilon_0 r} \quad [1]$$

which resolving S.E. gives for the ground state, with effective mass m^* :

$$E = -\frac{m^* e^4}{32\pi^2\epsilon_0^2\epsilon_r^2\hbar^2} \quad [2]$$

If the dopant electron is excited by this energy it will be free i.e., in the conduction band.

Hence the dopant state is

$$\frac{9.1 \times 10^{-31} \times 0.26 \times (1.6 \times 10^{-19})^3}{32\pi (8.85 \times 10^{-12})^2 144 (1.05 \times 10^{-34})^2} = 0.025 \text{ eV} \quad [2]$$

below the conduction band. (*new application of theory and calculation*)

d) The proportion of dopant states occupied is given by the Fermi distribution:

$$f(E) = \frac{1}{1 + \exp\left(\frac{E - E_f}{kT}\right)} \quad [1]$$

where E is the energy of the dopant level. In this case, as the Fermi energy is mid gap,

$$E - E_f = \frac{1.1}{2} - 0.025 = 0.525\text{eV} \quad [2]$$

This is much larger than kT (c. 1/40 eV) and so

$$\begin{aligned} f(E) &\approx \exp\left(-\frac{E - E_f}{kT}\right) \\ &\approx e^{-21} \\ &\approx 7.6 \times 10^{-10} \end{aligned} \quad [2]$$

Hence very few electrons remain in the dopant states – nearly all are thermalised. (*new application of theory and calculation*) [1]

3 a. For a block of the simple cubic crystal:

Cross-section of area A

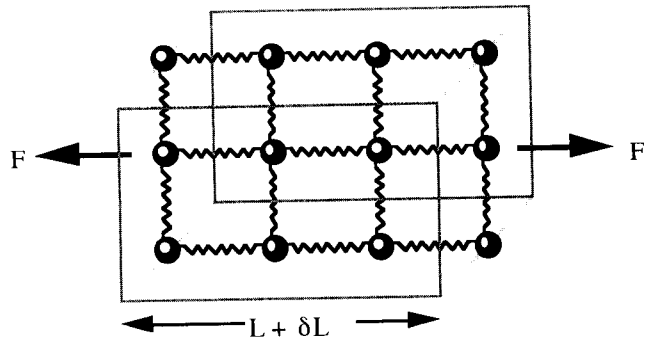
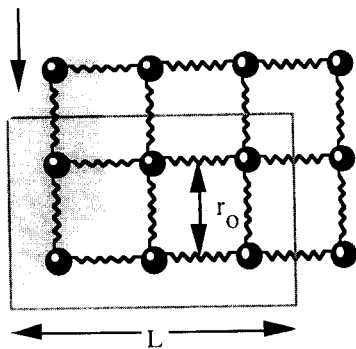

The number of bonds resisting the external force is

$$N_{yz} = \frac{A}{r_0^2} \quad [1]$$

From the definition of bond strength:

$$k = -\left. \frac{dF}{dr} \right|_{r=r_0} \quad [1]$$

each bond will produce a force:

$$\delta F_{bond} = -k \delta r \quad [1]$$

and so the overall force from the bonds will be

$$\begin{aligned} F_{bonds} &= N_{yz} \delta F \\ &= -Ak \frac{\delta r}{r_0^2} \end{aligned} \quad [1]$$

Hence the external force

$$F = -F_{bonds} = Ak \frac{\delta r}{r_0^2} \quad [1]$$

Now stress is given by

$$\sigma = \frac{F}{A} = k \frac{\delta r}{r_0^2} \quad [1]$$

and the strain

$$\epsilon = \frac{\delta L}{L} = \frac{N_x \delta r}{N_x r_0} = \frac{\delta r}{r_0} \quad [1]$$

giving

$$\begin{aligned} \sigma &= \epsilon E, \\ E &= \frac{k}{r_0^2} \end{aligned} \quad [1]$$

(bookwork)

b. The strain on the bundle will be compressive on the on the inside, tensile on the outside and zero in the centre. Stress along the fibre, σ , in terms of strain, ϵ , is given by:

$$\sigma_1 = E \epsilon_1$$

The strain is given by

$$\begin{aligned}\varepsilon_1 &= \frac{\frac{\pi}{2}(r + \Delta r) - \frac{\pi}{2}r}{\frac{\pi}{2}r} \\ &= \frac{\Delta r}{r}\end{aligned}\quad [1]$$

where Δr is the distance of the fibre from the centre of the bundle:

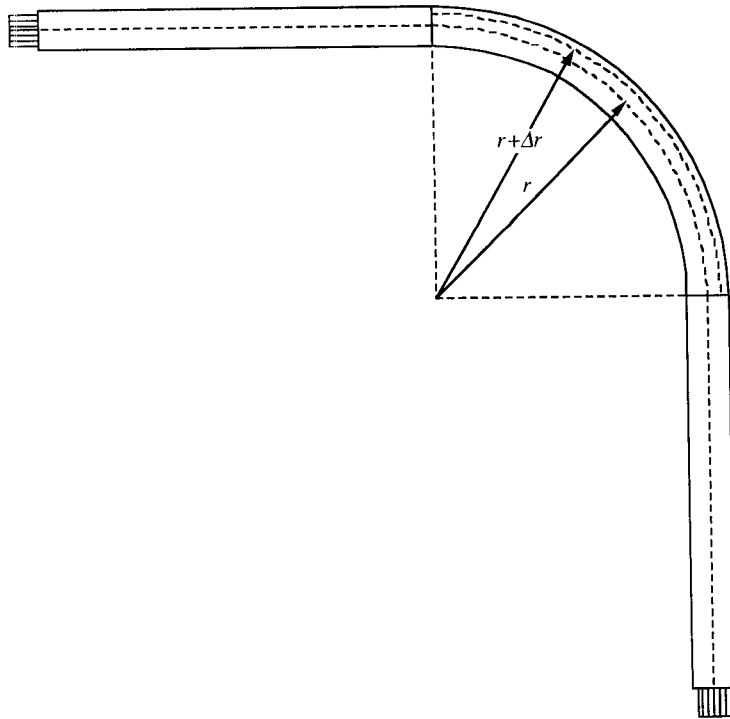

Hence the strain is given by

$$\sigma_1 = \frac{E\Delta r}{r} \quad [1]$$

The fractional change in the diameter results from the resulting orthogonal strain, and is proportional to Poisson's ratio, ν :

$$\sigma_2 = -\nu \frac{\Delta r}{r}$$

Hence the change in the diameter will be

$$\Delta d = -\nu d_0 \frac{\Delta r}{r} \quad [1]$$

Applying these relationships:

i)

$$\begin{aligned}\sigma_1 &= \frac{E\Delta r}{r} \\ &= 7 \times 10^{10} \times \frac{.25 \times 10^{-3}}{2.5} \\ &= 7 \times 10^6 \text{ Pa}\end{aligned}\quad [1]$$

$$\begin{aligned}\Delta d &= -vd_0 \frac{\Delta r}{r} \\ &= -0.17 \times 50 \times 10^{-6} \times 10^{-4} \\ &= -0.85 \text{ nm}\end{aligned}\quad [1]$$

ii)

$$\begin{aligned}\sigma_1 &= \frac{E\Delta r}{r} \\ &= 0 \text{ Pa} \\ \Delta d &= -vd_0 \frac{\Delta r}{r} \\ &= 0 \text{ nm}\end{aligned}\quad [1]$$

iii)

$$\begin{aligned}\sigma_1 &= \frac{E\Delta r}{r} \\ &= 7 \times 10^{10} \times -\frac{.25 \times 10^{-3}}{2.5} \\ &= -7 \times 10^6 \text{ Pa}\end{aligned}\quad [1]$$

$$\begin{aligned}\Delta d &= -vd_0 \frac{\Delta r}{r} \\ &= 0.17 \times 50 \times 10^{-6} \times 10^{-4} \\ &= 0.85 \text{ nm}\end{aligned}\quad [1]$$

(new application of theory and calculation)

c) The failure will be in extension – the bundle will break on the outside of the bend. [1]

From

$$\sigma_1 = \frac{E\Delta r}{r}$$

for a bundle of diameter D :

$$\begin{aligned}\sigma_{1\max} &= \frac{ED/2}{r_{\min}} \\ r_{\min} &= \frac{ED}{2\sigma_{1\max}} \\ &= \frac{7 \times 10^{10} \times 0.5 \times 10^{-3}}{2 \times 10^8} \\ &= 18.5 \text{ cm}\end{aligned}\quad [2]$$

which with a factor of ten for safety, gives a minimum radius of 1.85 m. *(new application of theory and calculation)*

[1]

4. a)

Region 1: orientational polarization: dipoles in a fluid will tend to align with the electric field increasing the dielectric constant at low frequencies. Thermal effects will tend to randomize the alignment, with a characteristic relaxation time, corresponding to the reciprocal of frequency of the mechanisms interaction. [1]

Region 2: molecular or ionic polarization. The ions or fractionally charged molecules will respond to the electric field, increasing the dielectric constant at low frequencies. [1]

Region 3: electronic polarization. The electrons themselves respond to the electric field, adding to the dielectric constant at low frequencies. [1]

$\epsilon_r'(\infty)$ will be one, as at very high frequencies there are no mechanisms that can respond fast enough to the electric field, and no polarization interaction is seen. [2]

The imaginary part:

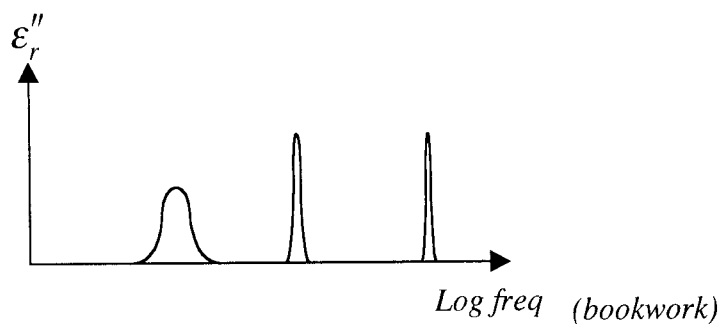

[2]

b) Capacitance is given by

$$C = \frac{\epsilon_0(\epsilon_r' - j\epsilon_r'')A}{d}$$

giving an effective capacitance of

$$C' = \frac{\epsilon_0\epsilon_r'A}{d} \quad [1]$$

and a loss tangent of

$$\tan \delta = \frac{\epsilon_r''}{\epsilon_r'} \quad [1]$$

Separating the dielectric constant into real and imaginary parts:

$$\begin{aligned}\varepsilon_r(\omega) &= \varepsilon_{r1} + \frac{\Delta\varepsilon_r}{1 + j\omega\tau} \\ \varepsilon_r'(\omega) &= \varepsilon_{r1} + \frac{\Delta\varepsilon_r}{1 + \omega^2\tau^2} \\ \varepsilon_r''(\omega) &= \Delta\varepsilon_r \frac{\omega\tau}{1 + \omega^2\tau^2}\end{aligned}\quad [2]$$

For

$$f = 100\text{kHz}, \omega\tau = 2\pi \times 10^{-1}$$

$$f = 1\text{MHz}, \omega\tau = 2\pi$$

$$f = 10\text{MHz}, \omega\tau = 2\pi \times 10$$

Hence the fraction of the DC capacitance at 100 kHz is

$$\frac{\Delta C}{C} = \frac{1.3 + \frac{2.1}{1 + 0.63^2}}{3.4} = 0.825 \quad [1]$$

at 1 MHz

$$\frac{\Delta C}{C} = \frac{1.3 + \frac{2.1}{1 + 6.3^2}}{3.4} = 0.398$$

[1]

at 10 MHz

$$\frac{\Delta C}{C} = \frac{1.3 + \frac{2.1}{1 + 63^2}}{3.4} = 0.382 \quad [1]$$

The loss tangent at 1MHz:

$$\begin{aligned}\tan \delta &= \frac{\varepsilon_r''}{\varepsilon_r'} \\ &= \frac{\omega\tau}{\frac{\varepsilon_{r1}}{\Delta\varepsilon}(1 + \omega^2\tau^2) + 1} \\ &= \frac{6.3}{\frac{2.1}{1.3}(1 + 6.3^2) + 1} \\ &= 0.094\end{aligned}\quad [2]$$

(new application of theory and calculation)

c) i. If the capacitor is heated, the relaxation time will decrease due to the increased thermal energy available to randomize the polarisation direction. Hence the transition in region 1 will be pushed to higher frequencies. [2]

ii. If the dielectric is frozen, orientational polarisation will no longer occur, and the curve will remain flat through region 1. [2]

(new application of theory)

5. a) Magnetic dipole for a current loop is given by:

$$\mu_m = IA \quad [1]$$

For an electron orbiting a nucleus at a radius r at a frequency f :

$$A = \pi r^2 \quad [1]$$

and the current

$$I = -ef = -e \frac{\omega}{2\pi} \quad [1]$$

Hence

$$\mu_m = -\frac{e\omega r^2}{2} \quad [1]$$

But the angular momentum is given by

$$L = mr^2\omega \quad [1]$$

and hence $\mu_m = -\frac{eL}{2m} \quad [1]$

(bookwork)

b) i. The electron concentration, n , is given by

$$n = \int_0^{E_f} g(E) dE \quad [2]$$

or graphically, n is the value of the shaded area:

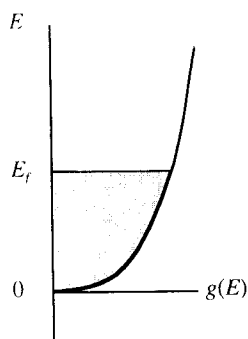

[2]

ii. The material contains equal numbers of spin-up and spin-down electrons. Under a magnetic field the spin-up electrons will align with the magnetic field, and the spin-down electrons against, lowering, or raising their energy respectively, by an amount

$$\Delta E = \mu_m \mu_0 H$$

The electrons in the highest-energy spin-down states will fall down into the unoccupied spin-up states until the highest energy levels in both cases is at the Fermi level. Hence there will be more spin-up electrons than spin-down electrons creating an overall magnetic dipole. The dipole will be aligned to the external magnetic field, and hence the material is paramagnetic. [4]

(new application of theory)

c). As the concentration of electrons remains constant, the number of spin-down electrons lost must equal the number of spin-up electrons gained. The corresponding excess in concentration of spin-up electrons must be

$$\begin{aligned}
\Delta n &= \int_{E_f}^{E_f + 2\mu_m \mu_0 H} g_{up}(E) dE \\
&= \frac{1}{2} \int_{E_f}^{E_f + 2\mu_m \mu_0 H} g(E) dE \\
&\approx \frac{1}{2} 2\mu_m \mu_0 H g(E_f) dE
\end{aligned}
\tag{3}$$

if $\mu_m \mu_0 H \ll E_f$.

The overall magnetisation is therefore

$$\begin{aligned}
M &= \Delta n \mu_m \\
&= \mu_m^2 \mu_0 g(E_f) H
\end{aligned}
\tag{2}$$

Hence the magnetic susceptibility is given by

$$\chi_m = \frac{M}{H} = \mu_m^2 \mu_0 g(E_f)
\tag{1}$$

(new application of theory)