

Paper Number(s): **E1.1**

IMPERIAL COLLEGE OF SCIENCE, TECHNOLOGY AND MEDICINE
UNIVERSITY OF LONDON

DEPARTMENT OF ELECTRICAL AND ELECTRONIC ENGINEERING
EXAMINATIONS 2001

EEE PART I: M.Eng., B.Eng. and ACGI

ANALYSIS OF CIRCUITS

Wednesday, 20 June 10:00 am

There are FIVE questions on this paper.

Answer THREE questions.

Time allowed: 2:00 hours

Examiners: Spence,R. and Weiss,G.

1. (a) For each of the circuits shown in Figure 1a below choose the value of R required to lead to a voltage V of 5 volts. Assume the operational amplifiers are ideal

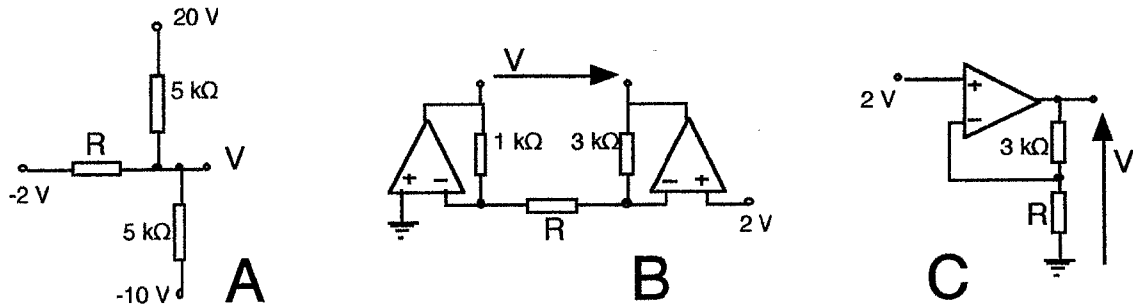

A[3]
B[4]
C[4]

Figure 1a

- (b) For each of the circuits shown in Figure 1b calculate, with explanation, one positive value of resistance R that will ensure that the indicated voltage or current lies somewhere within the specified range, or explain why this is not possible.

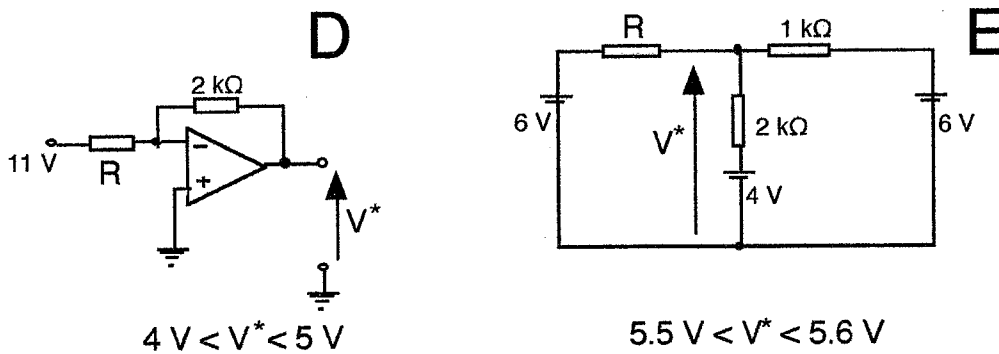

Figure 1b

D[4]
E[5]

- 2 (a) For the circuit of Figure 2a, express the complex impedance between the terminals A and B in terms of R_1 , R_2 , L , C and the radian frequency ω .

[7]

For what numerical value of the radian frequency will the impedance be purely resistive?

[3]

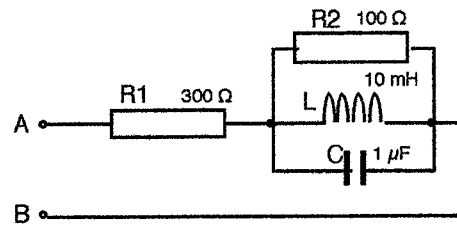

Figure 2a

- (b) Find the relation that must exist between L , C and R in the circuit of Figure 2b for the impedance between A and B to be resistive at all frequencies.

[10]

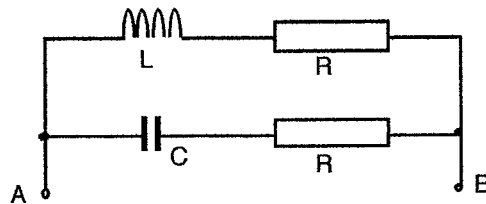

Figure 2b

3 Figure 3 shows a circuit in which a Schmitt Trigger is followed by an integrator. The output of each opamp is limited to plus and minus 14 V and the opamps are otherwise ideal.

(a) Choose R_1 so that the opamp A switches when V_B is equal to plus or minus 4 V. [7]

(b) Choose R_3 to give an oscillation frequency of 2 kHz. [7]

(c) If a $10\text{k}\Omega$ resistor is connected between point X and +15 V, draw a dimensioned sketch of the resultant waveform of V_B and calculate the new oscillation frequency [6]

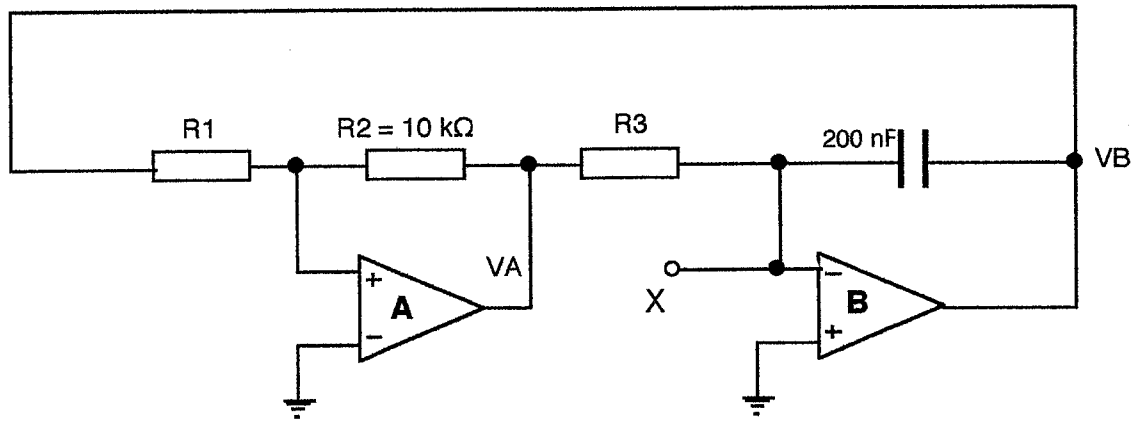

Figure 3

- 4 For the circuit of Figure 4, employ nodal analysis to derive the Thevenin Equivalent Circuit of the circuit external to the resistor R. [16]

Hence calculate the value of the current I for the following values of the resistor R: 0, 0.5 k Ω and 5.5 k Ω [4]

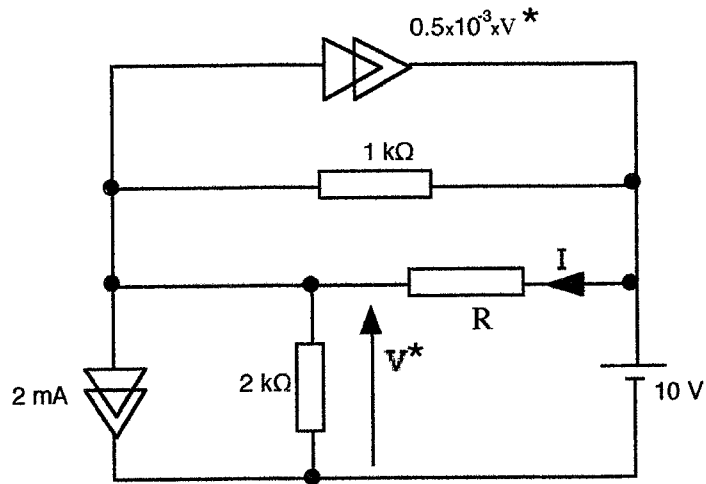

Figure 4

- 5 In the circuit of Figure 5 the voltage across each exponential diode can be assumed to be approximately 0.7 V if the diode current exceeds 0.2 mA.

Apply Kirchhoff's Current Law at point X and hence determine the quiescent voltage at this point and the current in each of the diodes.

[6]

Determine the small-signal equivalent resistance of each of the diodes.

[6]

Assuming that the impedance of the capacitor is negligible, draw the small-signal equivalent of the circuit and hence calculate the peak-to-peak amplitude of the sinusoidal voltage V.

[8]

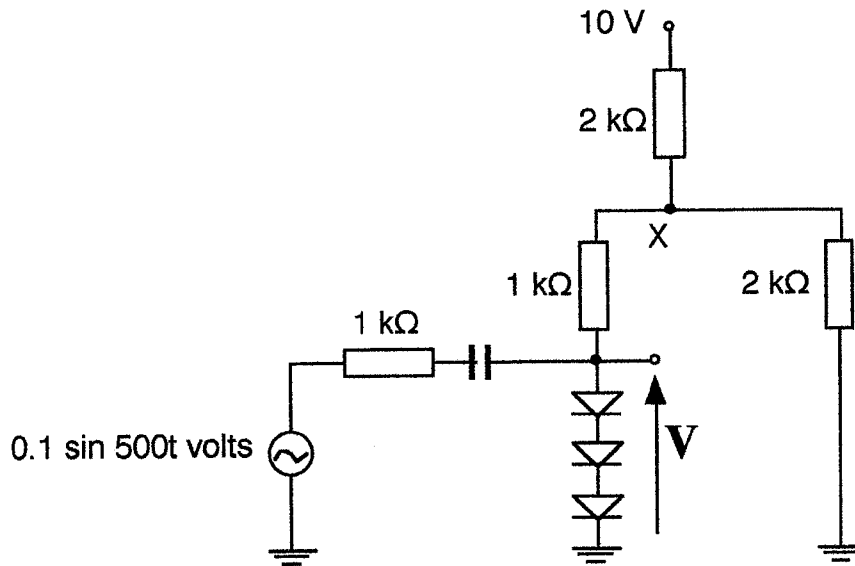

Figure 5

Answer 1

(a) (A) Apply KCL at node:

$$\frac{5+2}{R} = \frac{15}{5} - \frac{15}{5}$$

Thus $R = \infty$
(open circuit)(B) Current through R (R to L) = $2/R$

$$\therefore V = \frac{2}{R}(3+R+1) = \frac{2 \cdot 4}{R} + 2$$

$$V=5 \quad \therefore 3 = \frac{8}{R} \quad R = \frac{8}{3} \text{ k}\Omega.$$

(C) $V_+ = V_- = 2V = \frac{R}{3+R} \times 5V \quad \therefore 2(3+R) = 5R$

$$\therefore 6 = 3R \quad \therefore R = 2 \text{ k}\Omega.$$

(b) (D) Not possible. Current via R sets up a negative value of V^* (E) Choose $V^* = 5.55 \text{ V}$

$$\text{KCL gives: } \frac{1.55}{2} = \frac{0.45}{R} + \frac{0.45}{1}$$

$$\therefore \frac{0.45}{R} = 0.775 - 0.45 = 0.325$$

$$\therefore R = \frac{0.45}{0.325} \approx 1.4 \text{ k}\Omega.$$

Answer 2

(a) Impedance of parallel combination of R_2, L, C is

$$\frac{1}{\frac{1}{R_2} + \frac{1}{j\omega L} + j\omega C} = \frac{1}{\frac{1}{R_2} + j\left(\omega C - \frac{1}{\omega L}\right)}$$

so the total impedance Z between A and B is

$$Z = R_1 + \frac{1}{\frac{1}{R_2} + j\left(\omega C - \frac{1}{\omega L}\right)} \quad \text{which is resistive when } \omega C = \frac{1}{\omega L}$$

That is, when $\omega^2 = \frac{1}{LC} = 10^8$ i.e., for $\omega = 10^4$ radians/sec.

(b) The admittance Y between A and B is the sum of the admittances of the two branches:

$$\begin{aligned} Y &= \frac{1}{R + j\omega L} + \frac{1}{R + \frac{1}{j\omega C}} = \frac{R + \frac{1}{j\omega C} + R + j\omega L}{R^2 + \frac{\omega L}{\omega C} + R\left(j\omega L + \frac{1}{j\omega C}\right)} \\ &= \frac{2R + \left(j\omega L + \frac{1}{j\omega C}\right)}{R\left[\left(R + \frac{L}{CR}\right) + \left(j\omega L + \frac{1}{j\omega C}\right)\right]} \end{aligned}$$

For Y to be real, which it will be if impedance ($1/Y$) is resistive, for all values of ω , we must choose $\frac{L}{CR} = R$, whereupon

$Y = \frac{1}{R}$. Thus the required relation is

$$\frac{L}{C} = R^2$$

Answer 3

- (a) Transition of output of (A) occurs when v_+ of A is at zero. Assume output of (A) is at 14V.

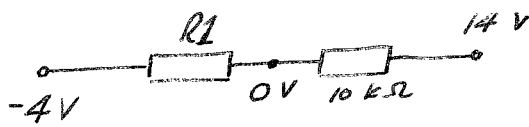

Since current is same through both resistors

$$\frac{4}{R_1} = \frac{14}{10k\Omega} \quad \text{so} \quad R_1 = \frac{40k\Omega}{14} = 2.86k\Omega$$

- (b) Waveform of V_B is as shown:

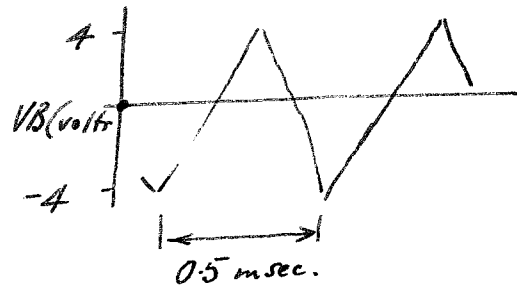

During falling section of V_B , charging current of $20\mu F$ capacitor

$$i = C \frac{dV}{dt} \quad \text{gives} \quad \frac{14}{R_3} = C \frac{8}{0.25 \times 10^{-3}}$$

$$\text{so } R_3 = \frac{14 \cdot 0.25 \cdot 10^{-3}}{8 \cdot 200 \cdot 10^{-9}} = \frac{14}{640} \times 10^6$$

$$\frac{14 \cdot 0.25 \cdot 10^{-3}}{8 \cdot 200 \cdot 10^{-9}} = \frac{14}{32 \cdot 200} \cdot 10^6 = \frac{7}{32} \cdot 10^4 = \frac{70}{32} k\Omega = 2.19 k\Omega$$

- (c) When $V_A = 14$ and has just changed from $-14V$, ($V_B = -$ capacitor voltage)

$$i = \frac{14}{R_3} + \frac{15}{10} = C \frac{dV}{dt} \quad \text{so} \quad \frac{dV_B}{dt} = -\frac{1}{200 \cdot 10^{-9}} (6.4 + 1.5) \cdot 10^{-3}$$

$$\frac{dV_B}{dt} = -\frac{7.9 \cdot 10^{-3}}{200 \cdot 10^{-9}}$$

$$\text{But change in } V_B \text{ is } 8V, \text{ so } dt = \frac{200 \cdot 10^{-9} \cdot 8 \cdot 10^3}{7.9 \cdot 10^{-3}} \text{ msec} = 202 \cdot 10^{-3} \text{ msec.}$$

When V_A has just changed back to $-14V$,

$$\frac{dV_B}{dt} = +\frac{1}{200 \cdot 10^{-9}} (6.4 - 1.5) \cdot 10^{-3}$$

$$\text{Again, } dV_B = 8V \text{ so } dt = \frac{8 \cdot 200 \cdot 10^{-9}}{4.9 \cdot 10^{-3}} = 326 \cdot 10^{-3} \text{ msec.}$$

The waveform of V_B is therefore as shown at right

and therefore the oscillation frequency is given by

$$f = \frac{10^6}{202 + 326} \text{ Hz} = 1.89 \text{ kHz}$$

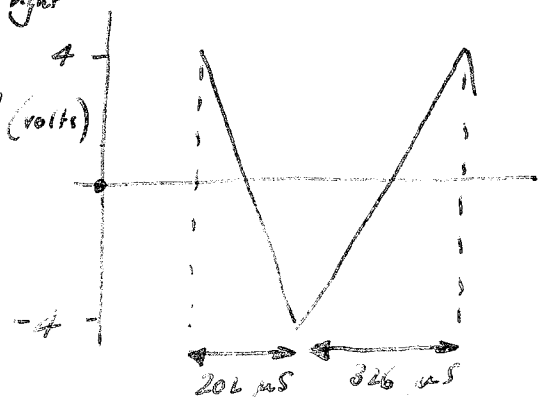

Answer 4

Calculate the Thevenin Equivalent Circuit of the circuit between terminals A and B shown below.

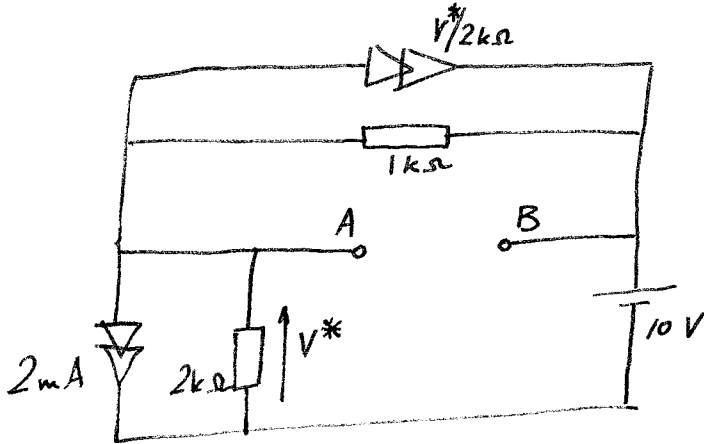

To find V_{oc} , apply KCL at A:

$$\frac{10 - V^*}{1} - \frac{V^*}{2} - 2 - \frac{V^*}{2} = 0 \quad \text{which gives } V^* = 4V$$

and therefore $V_{oc} = 6V$

To find R_0 set independent sources to zero:

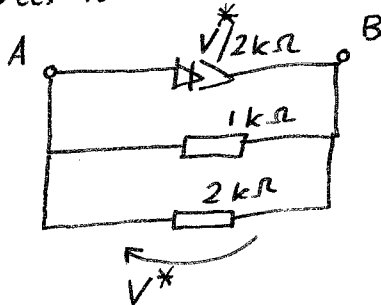

The controlled current is proportional to the voltage across it, and is therefore equivalent to a $2k\Omega$ resistor:

Resistance between A and B = $0.5k\Omega$

Circuit to be analysed:

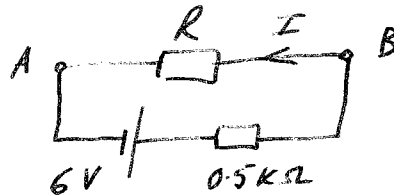

$$R = 0 \quad I = 12 \text{ mA}$$

$$R = 0.5k\Omega \quad I = 6 \text{ mA}$$

$$R = 5.5k\Omega \quad I = 1 \text{ mA}$$

Answer 5

Assume that the voltage across each diode is 0.7 V (and check later).

Application of KCL at node X yields

$$\frac{10 - V_x}{2} = \frac{V_x - 2.1}{1} + \frac{V_x}{2}$$

giving $V_x = 3.55\text{ V}$

Current through each diode is therefore $(3.55 - 2.1)/1\text{ mA} = 1.45\text{ mA}$
Assumption about diode voltages is therefore justified.

Small-signal resistance of each diode = $\frac{25\text{ mV}}{1.45\text{ mA}} = 17.24\ \Omega$

Small-signal equivalent circuit is:

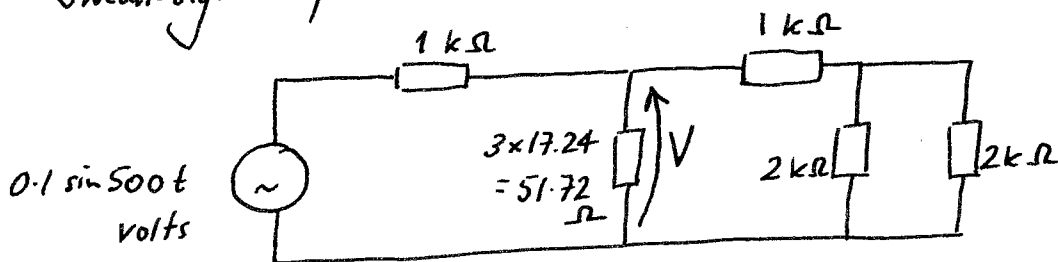

which can be redrawn as

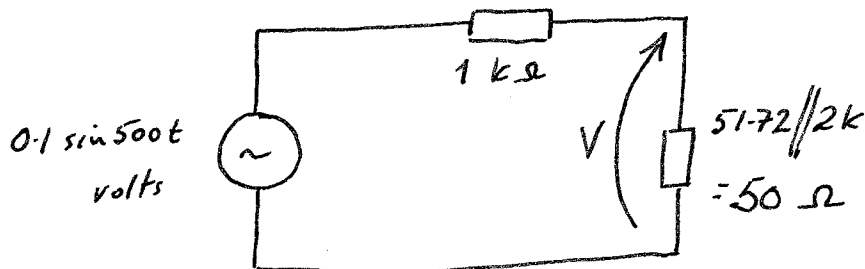

The peak-to-peak value of V is therefore $0.2 \times \frac{50}{1050} \approx 9.5\text{ mV}$

The variation of voltage ($\approx 3.2\text{ mV}$) across each diode is sufficiently small (i.e., $\ll 25\text{ mV}$) that the representation of a diode by a linear resistance is justified.