



MILLIKEN

MP3437

Grades 6-7

WORD POWER

VOCABULARY ENRICHMENT ACTIVITIES



Word Power
Reproducible Workbook
plus Teacher's Guide
Grades 6—7
by
Suzanne Lowe Wilke

Artist: Kathy Mitter

Copyeditor: Cindy Barden

Cover and Inside Design: Good Neighbor Press, Inc.

Each book in the Word Power series provides 22 activities which introduce more than 60 challenging new words chosen from popular literature at the designated level. This mode of selection expands the conventional basal vocabularies and ensures the usefulness of words learned. Three, two-page reviews reinforce learning.

Activity pages introduce new words in context. Reinforcement is provided in student activities matching words with their meanings, alphabetizing words, matching words with their antonyms, and completing puzzles.

All lessons are teacher-created. The teaching guide includes a list of source books for each level.

MP3437

Copyright © 2001 Milliken Publishing Company

St. Louis, Missouri

All rights reserved

Permission to reproduce pages extends to the teacher-purchaser for individual classroom use, not to exceed in any event more than one copy per student in a course.

The reproduction of any part for an entire school or school system or for commercial use is strictly prohibited.

Teaching Guide

This book is one of a series of five vocabulary enrichment texts created to add word power by expanding the working vocabularies of young readers and writers. Each book contains 22 new word activities and three, two-page review lessons. Each activity presents three new, challenging, and useful words for students at the designated grade. The content is of value to a wide range of students providing flexibility for use in grades above or below those for which each book was primarily intended.

This series is unique in its approach to choosing words for vocabulary activities. Teacher-authors use grade-appropriate children's literature (see book lists in each Teaching Guide) as sources for the basic word pool. The words recognized as above-level by ordinary readability standards provide a core of potentially useful words for vocabulary enrichment. Lessons combine the core words with related words—often a synonym and an antonym—to create a reasonable and practical learning environment. Words are then introduced in mini-stories for motivation, context clues, and maximum reinforcement of meaning.

Each activity provides for reading the new words in context and for practicing the words by using them in sentences as well as by finding synonyms, antonyms, and rhymes. There are crossword puzzles and decoding activities. Activities include independent writing assignments to encourage students to use words in meaningful ways. Sharing the written stories and expanding on the discussion of new words will further learning.

Teachers/parents are encouraged to have the books from the list available for students' recreational reading.

Book List

1. *From the Mixed-Up Files of Mrs. Basil E Frankweiler*, E. L. Konisburg
2. *Charlie and the Chocolate Factory*, Roald Dahl
3. *James and the Giant Peach*, Roald Dahl
4. *A Wrinkle in Time*, Madeleine L'Engle

Page	Key Words	Source	Page	Key Words	Source	Page	Key Words	Source
1	mysterious investigate solution	(1)	10	absurd dignified reasonable	(2)	20	exhilaration refresh fatigue	(1)
2	scarlet ivory indigo	(2)	11	agility flexible ponderous	(4)	21	loathe uninterested compromise	(2)
3	antique contemporary eclectic	(1)	12	antagonistic reconcile harmonious	(4)	22	duplicate carbon collated	(1)
4	genuine sincere impostor	(1)	13	infinite infinitesimal finite	(4)	23	geometric concentric parallel	(4)
5	mansion reside bungalow	(2)	14	serpentine coiled extended	(3)	24	cluster interval intersperse	(2)
6	elegant dowdy dilapidated	(1)	15	diverse resemble facsimile	(1)	25	focus reflected image	(4)
7	accumulate acquisitions dispersed	(1)	16	visual auditory verbal	(4)	26	desolate accessible convenient	(3)
8–9	Review Pages		17	decipher legible audible	(4)	27–28	Review Pages	
			18–19	Review Pages				

Glossary

- absurd** (əb sərd') – lacking reason, order, or common sense
- accessible** (ik ses' ə bəl) – easy to approach, enter, or use
- accumulate** (ə kyoo' myə lāt') – to collect, gather, or increase into a mass
- acquisitions** (ak wə zish' əns) – things which are acquired or gained
- agility** (ə jil' ət ē) – ability to move quickly and easily
- antagonistic** (an tag, ə nis' tik) – acting in a hostile and opposing manner
- antique** (an tēk') – dating from a past time, usually 100 years before the current time
- audible** (od' ə bəl) – actually heard or capable of being heard
- auditory** (od' ə tor' ē) – of, or pertaining to, the sense of hearing
- bungalow** (bən' gə lō) – a small, one-storied house
- carbon** (kar' bən) – a sheet of paper made of the chemical carbon which is used to make copies of the original sheet
- cluster** (kləs' tər) – a number of things that are grouped closely together
- coiled** (koyld) – to wind or gather into loops or rings
- collated** (ko lāt' əd) – collected or arranged (as sheets of paper) in a proper order
- compromise** (kom' prə mīz') – a settlement or agreement in which both sides give in a little to form a common ground
- concentric** (kən sen' trik) – having a common center, such as circles
- contemporary** (kən tem' pə rer' ē) – happening, existing, living, or coming into being the same period of time
- convenient** (kən vē' nyənt) – suitable to personal comfort or performance
- decipher** (di sī' fər) – to make out the meaning of
- desolate** (des' ə lət) – barren, isolated, and uninhabited
- dignified** (dig' nə fid) – having a stately and honorable manner
- dilapidated** (də lap' ə dāt' əd) – fallen into partial ruin or decay from misuse or neglect
- dispersed** (dis pərst') – sent off, or spread in various directions
- diverse** (dī vərs') – of various kinds and forms
- dowdy** (daood' ē) – not very neat or stylish
- duplicate** (doo' pli kət) – a copy exactly like the original
- eclectic** (e klek' tik) – made up of what is selected from different sources
- elegant** (el' i gent) – tastefully fine, or luxurious in appearance, style, or manner
- exhilaration** (ig zil' ə rā' shən) – a feeling of enlivenment, stimulation, or great cheer
- extended** (ik stend' əd) – stretched out to full length
- facsimile** (fak sim' ə lē) – an exact copy of something, such as a book, painting, manuscript, etc.
- fatigue** (fə tēg') – weariness from bodily or mental exertion
- finite** (fī' nīt) – having bounds or limits; not too great or too small to be measured
- flexible** (flek' sə bəl) – capable of being changed easily
- focus** (fō' kəs) – to clear and sharply define the condition of an image
- genuine** (jen' yə wən) – possessing the true qualities of something; the real thing
- geometric** (jē' ə me' trik) – characterized by straight and curved lines, circles, and figures used in geometry
- harmonious** (hor mō' nē əs) – agreement in feeling or action
- image** (im' ij) – of something or someone
- impostor** (im pos' tər) – a person who pretends to be something that he or she is not
- indigo** (in' di gō) – a dark blue color
- infinite** (in' fə nət) – immeasurable, or exceedingly great
- infinitesimal** (in fin, ə tes' ə məl) – exceedingly or immeasurably small
- intersperse** (int, ər spərs') – to place things at certain spaces among other things
- interval** (int' ər vəl) – a space between things or a space in time
- investigate** (in ves' tə gāt) – to use an orderly process to learn details about something
- ivory** (iv' ə rē) – a creamy white, or pale yellow, color like the substance of an elephant's tusk
- legible** (lej' ə bəl) – capable of being read
- loathe** (lōth') to dislike greatly
- mansion** (man' chən) – a very large, impressive, or stately residence
- mysterious** (mis tir' ē əs) – characterized by, or suggesting, a mystery
- parallel** (par' ə lel) – extending in the same direction, always equal, and never meeting at any point.
- ponderous** (pon' də rəs) – heavy and clumsy
- reasonable** (rēz' nə bəl) – possessing reason or sound judgment
- reconcile** (rek' ən sīl) – to restore to friendship or harmony
- reflected** (ri flekt' əd) – the casting back of an image, likeness, or outline from a surface
- refresh** (ri fresh') – to renew the well-being and vigor of oneself with rest, food, or drink
- resemble** (ri zem' bəl) – to be like or similar to
- reside** (ri zīd') – to live in a place, especially for a long time
- scarlet** (skar' lət) – a bright red color tending toward red-orange
- serpentine** (sə' pən tēn,) – having characteristics of, or resembling, a serpent in form or movement
- sincere** (sin sier') – free of falseness and deceit
- solution** (sə loo' shən) – an explanation for, or an answer to, a particular problem
- uninterested** (ən in' trest, d) – without interest or concern
- verbal** (vər' bəl) – of, relating to, or consisting of, words
- visual** (vizh' ə wəl) – of or pertaining to seeing or sight

Key Words

Name _____

mysterious
investigate
solution

The lady told the detective about the mysterious disappearance of her jewels. The detective agreed to investigate the matter of the missing jewels for her. After two days, he called to say that he had a solution to her mystery. Her dog had carried them off into its doghouse.



A. Look up each word in a dictionary. Write a definition for each.

1. mysterious _____
2. investigate _____
3. solution _____

B. Replace the words in parentheses with the appropriate key words.

1. The stranger acted in a (very strange) manner as he entered the room. _____
2. The inspector's job was to (inquire about) missing persons in the city. _____
3. The mystery writer saved her (explanation) until the last page of the book. _____

C. Circle the synonyms. Write the words you circle in the puzzle.

- | | | | | | | |
|----------------|------------|---------|--------|-------------|---------------|------|
| 1. mysterious | puzzling | explain | secret | strange | unexplainable | real |
| 2. investigate | research | inquire | speech | examine | search | add |
| 3. solution | unraveling | tangle | answer | explanation | finding | safe |

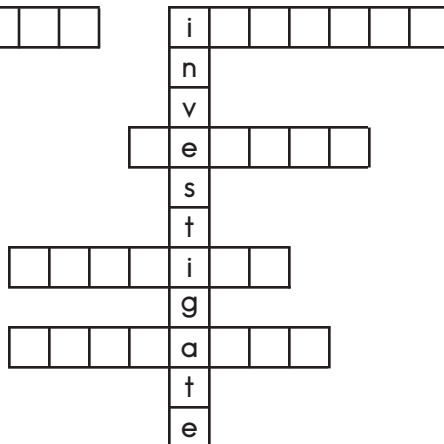
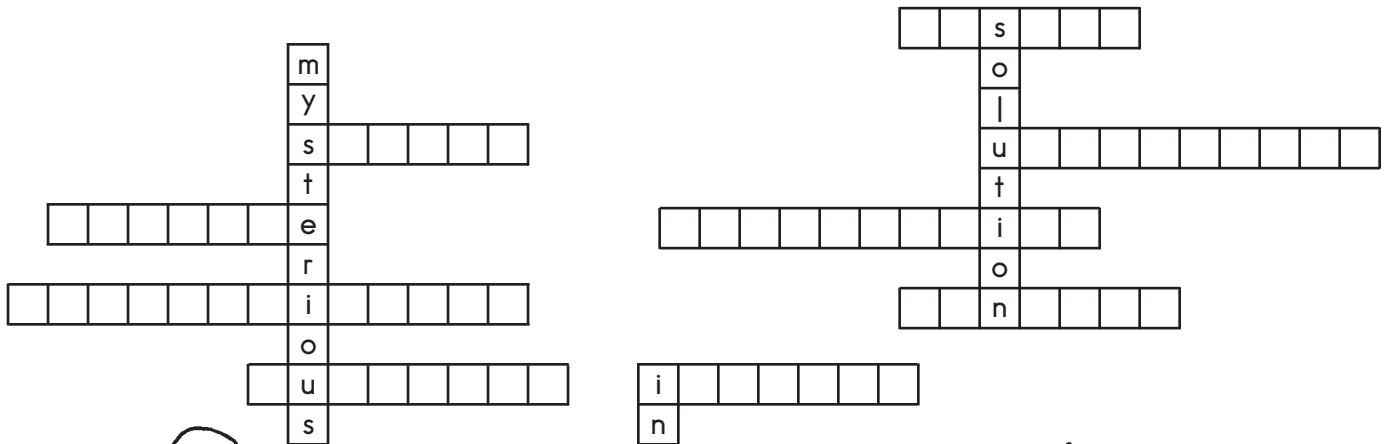

D. On another paper, write a paragraph about a police case. Use your new words.

Key Words

Name _____

scarlet
ivory
indigo

Jean's parents took her to the opera for the first time last Friday evening. Her city had renovated an old theater. This new opera theater featured a **scarlet** velvet stage curtain. The elaborately carved theater walls were painted **ivory** and gold. Each of the 1,000 seats was covered in vibrant **indigo** leather.

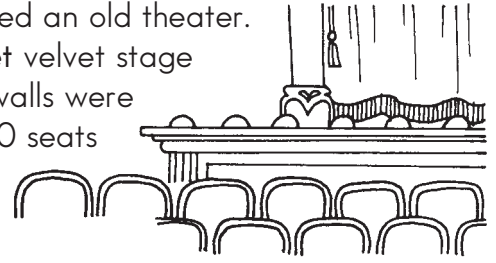

A. Look up each word in a dictionary. Write a definition for each.

1. **scarlet** _____

2. **ivory** _____

3. **indigo** _____

B. Put an x by each sentence which uses the word in bold correctly.

1. Pam caught a glimpse of the **scarlet** dress through the store window.

The girls put the **scarlet** on the shelf in their room.

2. The gardener planted **ivory** to grow under each large tree.

The pianist wore a long, black dress with an **ivory** lace collar

3. The lead Spanish dancer wore a bright **indigo** suit and hat.

The lady paid an **indigo** amount of money for the painting.



C. The color **scarlet** is bright red. bright orange.

Name three things which could be **scarlet**.

1. _____ 2. _____ 3. _____

D. The color **ivory** is yellowish brown creamy white.

Name three things which could be **ivory**.

1. _____ 2. _____ 3. _____

E. The color **indigo** is dark blue. light blue.

Name three things which could be **indigo**.

1. _____ 2. _____ 3. _____

F. On another paper, write a paragraph about a costume in a play. Use your new words.

Key Words

Name _____

antique
contemporary
eclectic

Mrs. Craft always dresses well. She really knows how to buy clothes. She owns many beautiful **antique** dresses and coats. For everyday wear, she likes to dress in more **contemporary** clothes. But occasionally she enjoys dressing in an **eclectic** style.



A. Look up each word in a dictionary. Write a definition for each.

1. antique _____

2. contemporary _____

3. eclectic _____

B. Circle the phrase which describes each key word.

1. The **antique** cupboard had once belonged to Beth's great-grandmother.
a. heavy and large b. one-of-a-kind c. very old
2. The lobby contained **contemporary** paintings by many artists.
a. made by hand b. recent time c. soft colors
3. The selection of books reflected the **eclectic** taste of the readers.
a. from different sources b. all alike c. strange and unusual

C. Circle the synonyms.

- | | | | | | |
|------------------------|---------------|---------|---------|-----------|----------|
| 1. antique | old-fashioned | quaint | unusual | classical | heavy |
| 2. contemporary | out-dated | current | modern | expensive | recent |
| 3. eclectic | selective | single | varied | combined | gigantic |

D. Describe the things which could be classified as **antique**.

1. _____
2. _____
3. _____

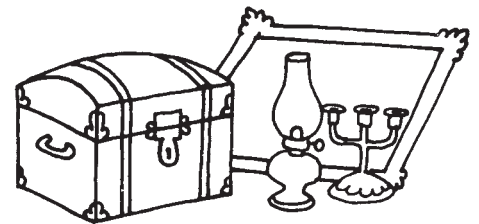

E. Check the items which could be described as **contemporary**.

- brand-new dress grandmother's watch sofa of recent design

F. On another paper, write a paragraph about your favorite chairs. Use your new words.

Key Words

Name _____

genuine
sincere
imposter

Many people went to the new flea market for good deals on jewelry. The salesman there assured the crowd that the jewelry was **genuine**. Many people believed him to be **sincere** and bought his jewelry. Later, they discovered that he was an **imposter** and his jewelry was fake.



A. Look up each word in a dictionary. Write a definition for each.

1. **genuine** _____

2. **sincere** _____

3. **imposter** _____

B. Rewrite each sentence. Replace the words in parentheses with the appropriate key words.

1. Matt's father wanted to purchase a (real) leather briefcase.

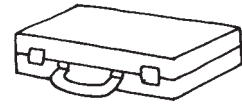

2. The (faker) tried to pretend that he was actually a famous artist.

3. The chairman was (truthful) when he thanked the committee for its hard work.

C. Circle the synonyms.

1. **genuine** real proven doubtful unsure true actual
2. **sincere** earnest deceitful undisguised honest false truthful
3. **imposter** deceiver pretender honest fraud generous faker

D. Write the correct word on each line.

1. _____ I really do appreciate your help on this project.
2. _____ I'll fool them by pretending to be a reporter.
3. _____ This is a real necklace from ancient times.

E. On another paper, write a paragraph about a movie plot. Use your new words.



Key Words

Name _____

mansion
reside
bungalow

The old Kirkland mansion was donated to the city as a museum. The last person to reside in the mansion, Robert Kirkland, had died twenty years ago. He was a famous painter and a collector of fine art. The caretaker of the mansion lived in a bungalow on the estate.



A. Look up each word in a dictionary. Write a definition for each.

1. mansion _____

2. reside _____

3. bungalow _____

B. Cross out the word in each sentence which does not belong. Rewrite each sentence using a key word.

1. The cozy daydream was located on a small lot near the lake.

2. The Parker family wanted to attend in a town close to the sea.

3. The incredible occasion contained over one hundred rooms.

C. Check each word which might describe a mansion.

- modest simple stately impressive enormous



D. Name three other large places where someone might reside.

1. _____ 2. _____ 3. _____

E. Check each word which might describe a bungalow.

- small cottage elaborate quaint cozy



F. Name three other small places where someone might reside.

1. _____ 2. _____ 3. _____

G. On another paper, write a paragraph about traveling to a famous city. Use your new words.

Key Words

Name _____

elegant
dowdy
dilapidated

The city was restoring an old, run-down building. The deserted building had once been an elegant hotel. Nothing in the grand hotel had been simple or dowdy. The once beautiful building would no longer stand dilapidated and deserted.



A. Look up each word in a dictionary. Write a definition for each.

1. elegant _____
2. dowdy _____
3. dilapidated _____

B. Rewrite each sentence. Replace the words in parentheses with the appropriate key words.

1. The abandoned school had become (decayed) from years of neglect.

2. The actress's part called for her to have a very (frumpy) appearance.

3. The guests at the formal dinner were dressed in (elaborate) clothes.

C. Circle the synonyms.

- | | | | | | | |
|----------------|--------------|-----------|---------|-----------|--------|---------------|
| 1. elegant | luxurious | unusual | refined | lovely | dismal | elaborate |
| 2. dowdy | unattractive | messy | fancy | unstylish | bright | frumpy |
| 3. dilapidated | perfect | crumbling | decayed | sagging | neat | deteriorating |

D. If you were dressed in **elegant** clothing you would

- be dressed in a neat, sporty outfit.
- be dressed in a luxurious, dressy outfit.

E. If you were dressed in **dowdy** clothing, you would

- be dressed in an unstylish, messy outfit.
- be dressed in a bright, floppy outfit.

F. A **dilapidated** building would be

- inhabitable
- uninhabitable.



G. On another paper, write a paragraph about a once beautiful home. Use your new words.

Key Words

Name _____

accumulate
acquisitions
dispersed

Through the years people seem to **accumulate** many different things. Some **acquisitions** are important to the owner and are saved for years. Other items are eventually **dispersed** by sales or gifts to charity. Sometimes people have to throw items away, too. If they saved everything they accumulated, they would eventually run out of closet space.



A. Look up each word in a dictionary. Write a definition for each.

1. accumulate _____

2. acquisitions _____

3. dispersed _____

B. Put an x by each sentence which uses the key word correctly.

1. It is easy for travelers to accumulate many kinds of souvenirs.
 The students knew they should accumulate before the test.
2. The lady wrote a letter to make her acquisitions clear.
 The captain's acquisitions reflected his love for sailing.
3. The campaign workers were dispersed to work in many different neighborhoods.
 The supermarket clerk dispersed the food into one sack.

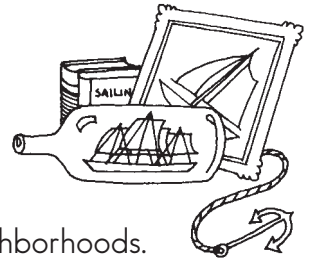

C. Circle the synonyms.

1. **accumulate** assemble collect destroy gather give
2. **acquisitions** acquired release possessions select obtain
3. **dispersed** scattered expected distributed saved spread

D. Name five things which a person might **accumulate**.

1. _____
2. _____
3. _____
4. _____
5. _____

E. Which could be called an **acquisition**?

- automobile weather clothes furniture time

F. On another paper, write a paragraph about an attic storeroom. Use your new words.

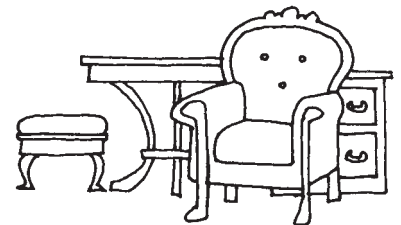

Review

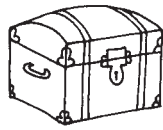

A. Number the words from 1 to 21 to put them in alphabetical order.

- | | | |
|-------------------|--------------------|-------------------|
| _____ mysterious | _____ antique | _____ mansion |
| _____ investigate | _____ contemporary | _____ reside |
| _____ solution | _____ eclectic | _____ bungalow |
| _____ scarlet | _____ genuine | _____ elegant |
| _____ ivory | _____ sincere | _____ dowdy |
| _____ indigo | _____ impostor | _____ dilapidated |
| _____ accumulate | _____ acquisitions | _____ dispersed |

B. Match the words and definitions.

- | | |
|---------------------|---|
| 1. _____ elegant | a. characterized by or suggesting a mystery. |
| 2. _____ sincere | b. to live in a place for a long time. |
| 3. _____ mysterious | c. made up of selections from different sources. |
| 4. _____ eclectic | d. fine or luxurious in appearance, style, or manner. |
| 5. _____ reside | e. a creamy white or pale yellow. |
| 6. _____ ivory | f. free of falseness and deceit. |
| 7. _____ dispersed | g. sent off or spread in various directions. |

C. Replace the word or phrase in parentheses with the appropriate key words.

acquisitions dowdy genuine investigate contemporary bungalow indigo

1. _____ The detective decided to (inquire about) the art theft.
2. _____ The stranger was dressed in (unstylish) clothes.
3. _____ The tropical shirt had an (deep blue) and yellow design.
4. _____ The necklace was made with (real) pearls.
5. _____ The (cottage) was a perfect place for the artist to live.
6. _____ The store featured mostly (modern) furniture.
7. _____ The old man had many (things) on his shelves.

Review

D. Choose the correct word to complete each sentence. Fill in the puzzle.
 dilapidated antique scarlet accumulate mansion solution impostor

Across

- 2. The machines began to tear down the old _____ building.
- 5. The detective discovered the _____ to the mystery.
- 6. The _____ used many different disguises.
- 7. The city trash collector can _____ a lot of trash.

Down

- 1. The stately _____ sits high on a hill.
- 3. The _____ flag fluttered in the wind.
- 4. The _____ sale had many valuable items.

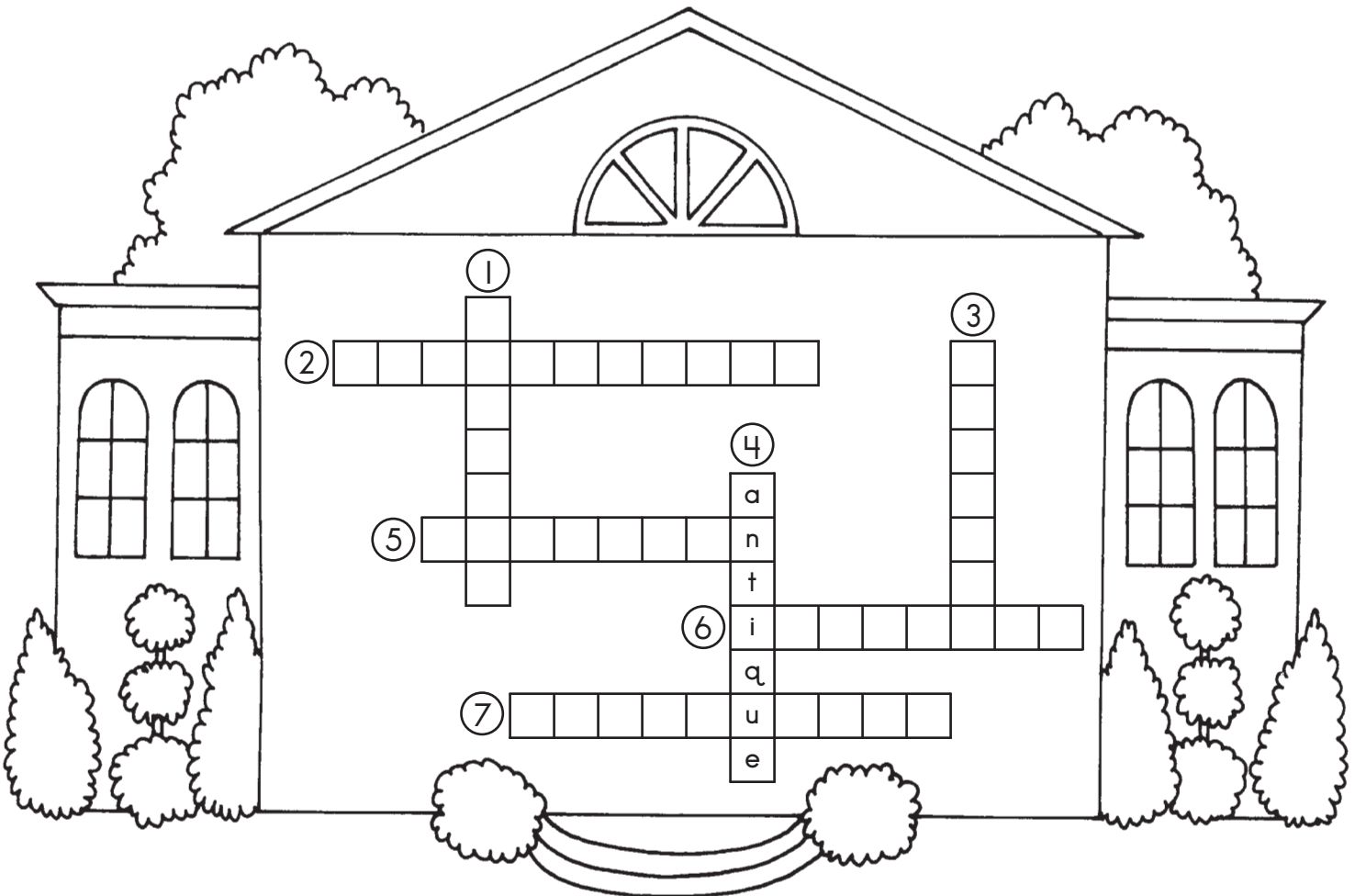

Key Words

Name _____

absurd
dignified
reasonable

The director ordered new costumes for the performers. The dancers' costumes looked more like clown suits. These performers thought their new costumes looked a little **absurd**. They asked that more **dignified** costumes be designed for them. Their **reasonable** request resulted in new costumes for all.

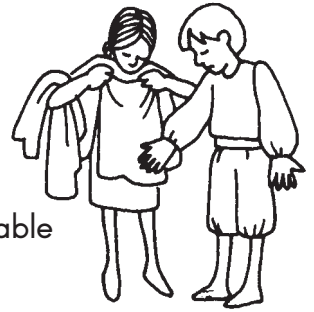

A. Look up each word in a dictionary. Write a definition for each.

1. **absurd** _____
2. **dignified** _____
3. **reasonable** _____

B. Rewrite each sentence. Replace the words in parentheses with the appropriate key words.

1. The participants in the ceremony performed in a (proper) manner.

2. The students thought their idea for a class trip was a (rational) one.

3. Frank was afraid that people would think his idea was (senseless).

C. Write the synonyms to the key words in the puzzle.

honorable crazy logical proud stupid agreeable
stately unreasonable sensible ridiculous fair grand

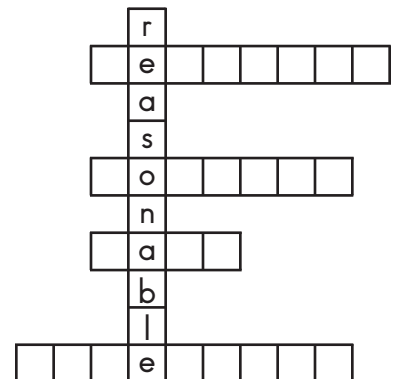
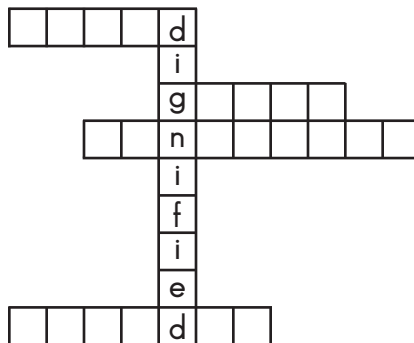
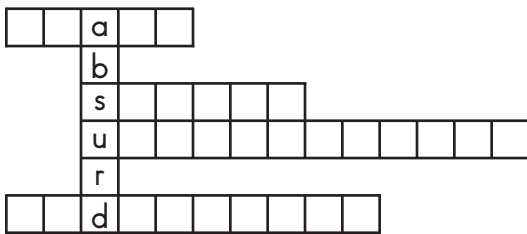

D. Name two things you consider **absurd**.

1. _____
2. _____

E. Name a **dignified** occasion. _____

F. On another paper, write a paragraph about a circus act. Use your new words.

Key Words

Name _____

agility
flexible
ponderous

It takes a person with agility and coordination to be a gymnast. Gymnasts need to be flexible in order to make the quick flips and turns. A more ponderous person would find it difficult to perform these routines. A person not used to doing gymnastics should be careful.

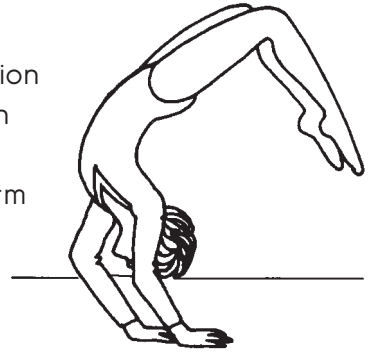

A. Look up each word in a dictionary. Write a definition for each.

1. agility _____
2. flexible _____
3. ponderous _____

B. Cross out the word in each sentence which does not belong. Rewrite each sentence using a key word.

1. Because of its letter, the cat was able to jump quickly out of the car's path.

2. The auto mechanic used a rubber tube because it was so absent.

3. The answer weight lifter lumbered slowly into the room.

C. Circle the synonyms.

1. **agility** coordinated small quick active clumsy nimble
2. **flexible** stiff bending liquid limber elastic supple
3. **ponderous** heavy airy massive weighty tiny cumbersome

D. In which activities would it help to have agility.

- swimming speaking reading
 watching T.V. biking skiing

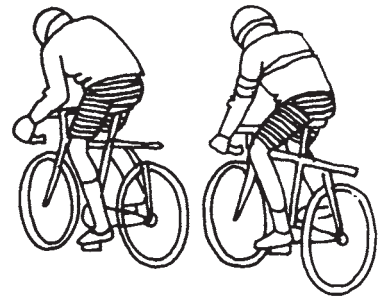

E. Underline the following materials which could be described as flexible.

rubber concrete elastic putty glass clay

F. On another paper, write a paragraph about playing basketball. Use your new words.

Key Words

Name _____

infinite
infinitesimal
finite

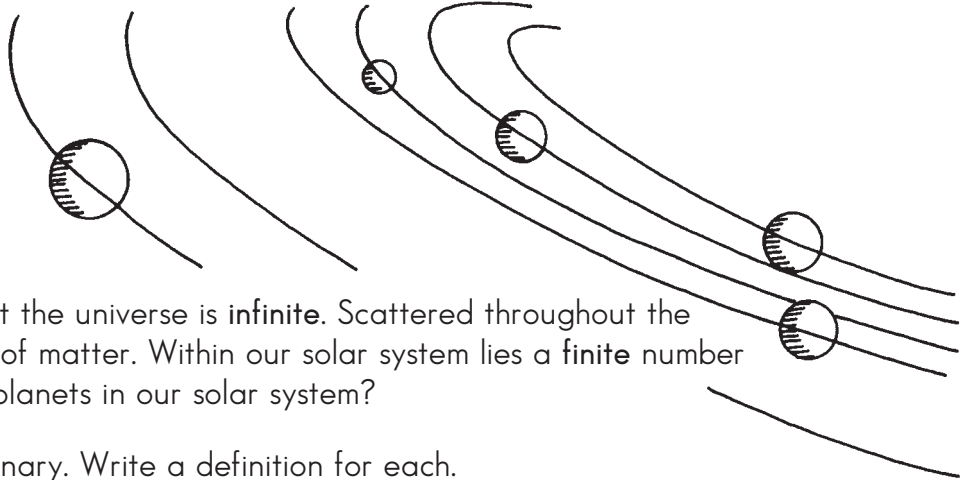

The astronomer explained that the universe is **infinite**. Scattered throughout the universe are **infinitesimal** particles of matter. Within our solar system lies a **finite** number of planets. Can you name all the planets in our solar system?

A. Look up each word in a dictionary. Write a definition for each.

1. **infinite** _____
2. **infinitesimal** _____
3. **finite** _____

B. Put an x by each sentence which uses the key word correctly.

1. The discovery of the disease's cure was of infinite importance.
 There were an infinite number of legs on each chair.
2. The two cars were infinitesimal together in the driveway.
 There was an infinitesimal amount of rain during the night.
3. There were a finite number of pebbles in the jar.
 The ocean contains a finite number of drops of water.

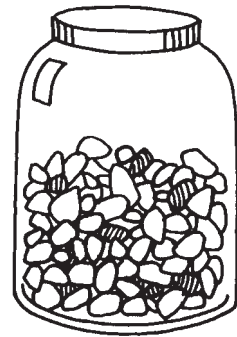

C. If something can be described as **infinite**, it is

- unlimited. small. immeasurable. countless. continual.

D. Name three things which are **infinite**.

1. _____ 2. _____ 3. _____

E. If something can be described as **finite**, it is

- limited. bounded. measurable. endless. restricted.

F. Name three things which are **finite**.

1. _____ 2. _____ 3. _____

G. If something is **infinitesimal**, it is

- tiny. immeasurably small. too many to count.

H. Name something which is **infinitesimal**. _____

I. On another paper, write a paragraph about the ocean. Use your new words.

Key Words

Name _____

serpentine
coiled
extended

Serpentine jewelry was worn by people of an ancient culture. Cleopatra, an Egyptian queen, probably wore a lot of serpentine jewelry. Each gold coiled bracelet ended with a serpent's head on top. One necklace featured an extended serpent on a gold chain.



A. Look up each word in a dictionary. Write a definition for each.

1. serpentine _____
2. coiled _____
3. extended _____

B. Circle the phrase which describes each key word.

1. The serpentine road twisted and curved through the mountains.
a. brown, snake-like color b. snake-like shape c. straight and long
2. The rattlesnake was coiled unseen under the dry leaves.
a. gathered into rings b. slowly moving c. perfectly still
3. The banner was extended over the department store's entrance.
a. brightly painted b. covered with letters c. stretched out

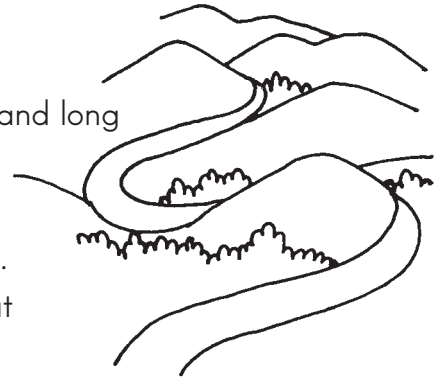

C. Write coiled or extended under each picture.

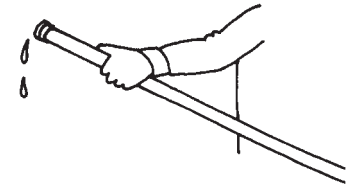
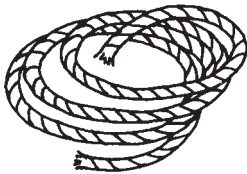

1. _____ 2. _____ 3. _____

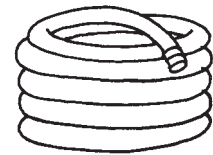
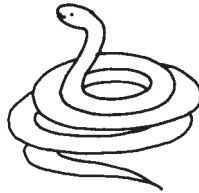
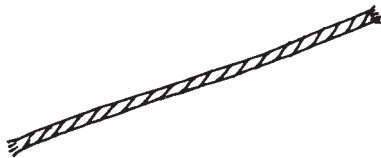

4. _____ 5. _____ 6. _____

D. List four things which could be described as serpentine.

1. _____ 2. _____ 3. _____ 4. _____

E. On another paper, write a paragraph about snakes. Use your new words.

Key Words

Name _____

diverse
resemble
facsimile

The geologist examined the diverse display of rocks on the cliff. He hoped to find a rock which would resemble those in his most valuable collection. To his surprise, he discovered a perfect facsimile of his rarest rock. Both rocks had red and green stripes with black dots.



A. Look up each word in a dictionary. Write a definition for each.

1. diverse _____
2. resemble _____
3. facsimile _____

B. Rewrite each sentence. Replace the words in parentheses with the appropriate key words.

1. Bob wanted a new jacket which would (be similar to) his friend's jacket.

2. The lawyer's paper was a (exact copy) of the original document.

3. The bookstore had a (various kinds) selection of reading material.

C. Check each synonym for **diverse**.

- different varying identical dissimilar

Name two things which would be **diverse** from each other.

1. _____
2. _____

D. Check each word that means about the same as **resemble**.

- similar opposite alike match

Name two things which could **resemble** each other.

1. _____
2. _____

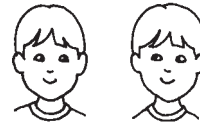

E. Check each synonym for **facsimile**.

- reproduction duplicate pattern variety

Name two things for which you could have a **facsimile**.

1. _____
2. _____

F. On another paper, write a paragraph about an art collection. Use your new words.

Key Words

Name _____

visual
auditory
verbal

Mrs. Carson recently had a baby girl named Sarah. Mrs. Carson wants to make sure that Sarah has every opportunity to learn and develop. Sarah's room has many bright colors to develop her **visual** skills. Listening to music will help develop her **auditory** skills, too. In time, Sarah will begin to develop good **verbal** skills by listening to others talk.



A. Look up each word in a dictionary. Write a definition for each.

1. visual _____
2. auditory _____
3. verbal _____

B. Write the key word that fits the meaning of each sentence.

1. _____ The kids like to listen to their favorite records.
2. _____ People filled the gallery to see the new art exhibit.
3. _____ Sharon likes to talk on the phone to her friends.
4. _____ The album contained pictures taken on Pat's vacation.
5. _____ The pilot listened for flight instructions on the radio.
6. _____ The counselor spoke to the campers about the day's activities.

C. Write the key word that is closest to the meaning of each word.

- | | | |
|---------------|-------------|---------------|
| _____ observe | _____ hear | _____ look |
| _____ listen | _____ watch | _____ declare |
| _____ speak | _____ talk | _____ see |

D. Name three activities in which you use each skill.

visual 

auditory 

verbal 

- | | | |
|----------|----------|----------|
| 1. _____ | 1. _____ | 1. _____ |
| 2. _____ | 2. _____ | 2. _____ |
| 3. _____ | 3. _____ | 3. _____ |

E. On another paper, write a paragraph about friends watching a parade. Use your new words.

Key Words

Name _____

decipher
legible
audible

The archeologists worked for months to decipher the ancient code on the stone wall. Because of the cave's rough surface, the carvings were barely legible. There is a legend that says audible moans and voices could once be heard behind the mysterious wall. Do you believe that something was alive there?

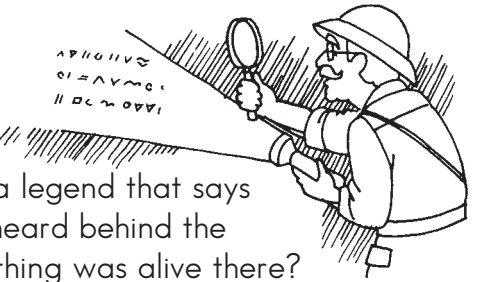

A. Look up each word in a dictionary. Write a definition for each.

1. decipher _____
2. legible _____
3. audible _____

B. Put an x by each sentence which uses the key word correctly.

1. The agent worked for days trying to decipher the code.
 The decipher was used to unlock the antique trunk.
2. The student's notebook was made of a legible plastic.
 The teacher said that everyone's report was neat and legible.
3. The speaker's voice was barely audible in the back of the room.
 The history book was audible enough for everyone to read.



C. If something is legible, it is

- capable of being read. extremely difficult to read.

Name three examples of things which are legible.

1. _____
2. _____
3. _____

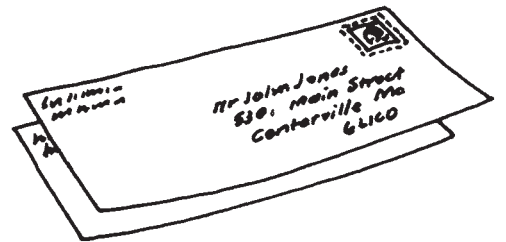

D. If something is audible, it is

- capable of being heard. extremely difficult to hear.

Name three examples of things which are audible.

1. _____
2. _____
3. _____

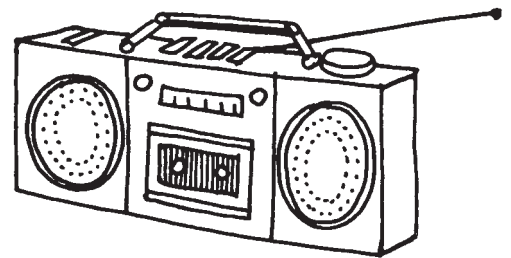

E. If you decipher something, you

- try to write something clearly. try to understand its meaning.

F. On another paper, write a paragraph about a strange book. Use your new words.

Review

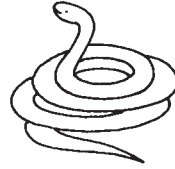
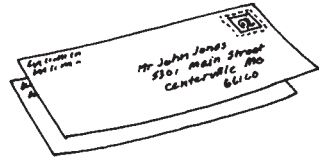

A. Number the words from 1 to 24 to put them in alphabetical order.

- | | | |
|------------------|---------------------|------------------|
| _____ absurd | _____ antagonistic | _____ serpentine |
| _____ dignified | _____ reconcile | _____ coiled |
| _____ reasonable | _____ harmonious | _____ extended |
| _____ agility | _____ infinite | _____ diverse |
| _____ flexible | _____ infinitesimal | _____ resemble |
| _____ ponderous | _____ finite | _____ facsimile |
| _____ visual | _____ auditory | _____ verbal |
| _____ decipher | _____ legible | _____ audible |

B. Match the words and definitions.

- | | |
|------------------------|---|
| 1. _____ diverse | a. the power of moving quickly and easily |
| 2. _____ extended | b. exceedingly small or immeasurably small |
| 3. _____ agility | c. to stretch out to full length |
| 4. _____ reconcile | d. not possessing reason or common sense |
| 5. _____ infinitesimal | e. of various kinds and forms |
| 6. _____ absurd | f. to cause a stop to hostility or opposition |
| 7. _____ verbal | g. capable of being heard |
| 8. _____ audible | h. of, relating to, or consisting of words |

C. Replace the () words or phrases with key words.

reasonable infinite ponderous resemble legible visual antagonistic serpentine

1. _____ The painting featured a (snake-like) design.
2. _____ The girl wanted a hat which would (be similar to) the one she lost.
3. _____ The angry boys acted (hostile) toward each other.
4. _____ The beach contains (immeasurable) grains of sand.
5. _____ The (heavy) wrestler lumbered into the ring.
6. _____ The shopper thought the price of lamb was (sensible).
7. _____ The space museum has many (sight) effects.
8. _____ The teacher told the class to make their reports (readable).

Review

D. Choose the correct word to complete each sentence. Fill in the puzzle.
 harmonious facsimile dignified flexible finite coiled auditory decipher

Across

2. The game has a _____ number of cards.
3. The meeting had a _____ atmosphere.
4. The rubber band is _____.
5. The scientist had to _____ the ancient code.
7. The snake was _____ under a rock.

Down

1. The ceremony was a _____ occasion.
4. The book was a _____ of the original.
6. Listening to the record made use of _____ skills.

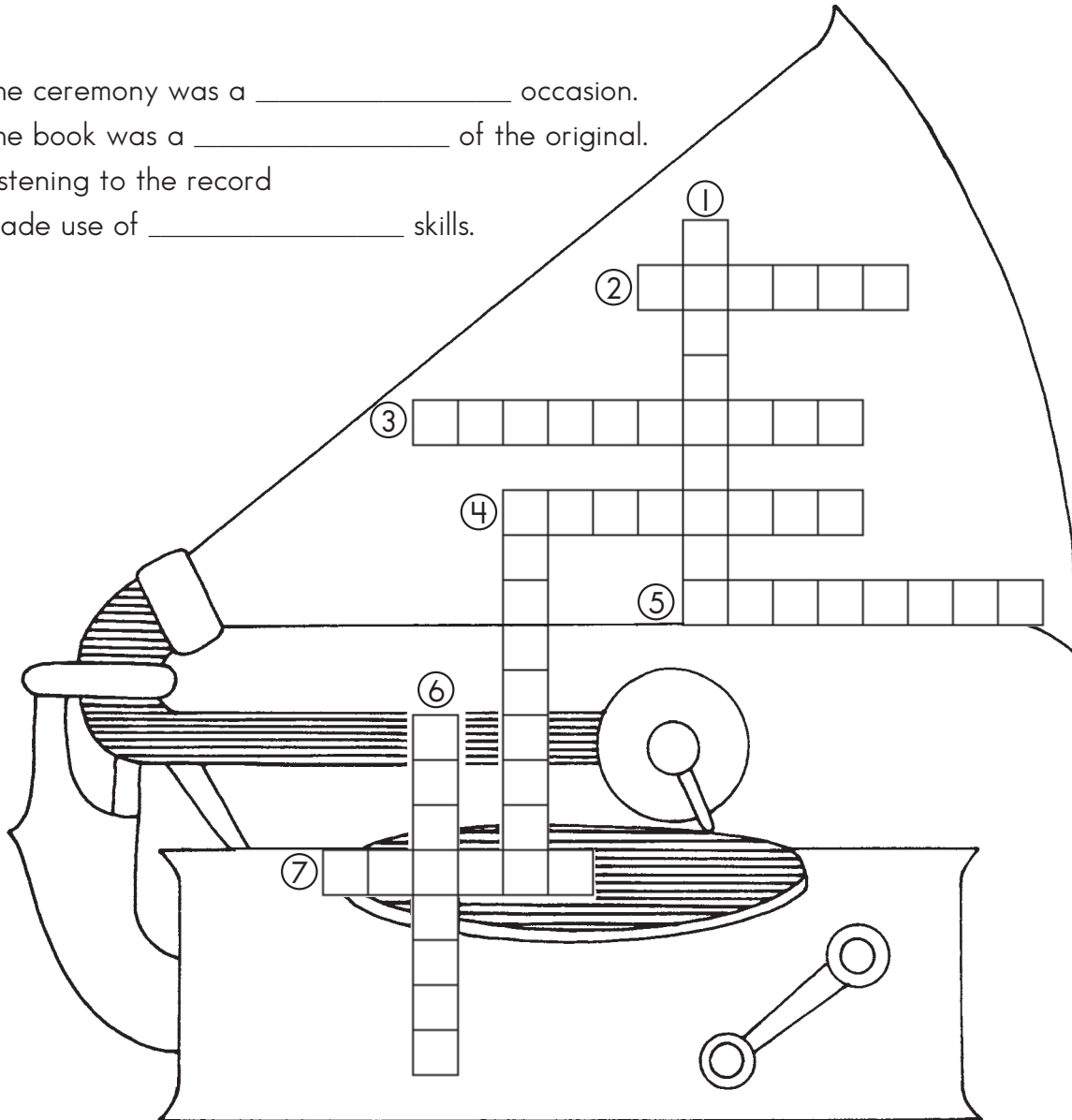

Key Words

Name _____

exhilaration
fatigue
refresh

The baseball team left the field feeling the exhilaration of victory. Back in the locker room, they felt fatigue from playing so hard. To refresh themselves, they showered and rested before the victory dinner. After eating dinner, they had enough energy to play another game.



A. Look up each word in a dictionary. Write a definition for each.

1. exhilaration _____
2. fatigue _____
3. refresh _____

B. Rewrite the sentences. Replace the words in parentheses with the appropriate key words.

1. By the end of the day, the movers had muscle (tiredness) from lifting heavy furniture.

2. The hikers decided to (freshen) themselves with a swim before lunch.

3. The kids could still remember the (thrill) of riding in a hot-air balloon.

C. Check the synonyms.

exhilaration

elatedness

thrill

relaxed

liveliness

fatigue

exhaustion

weariness

weakness

stimulate

refresh

saddened

revive

renew

restore

D. List two things which give you a feeling of exhilaration.

1. _____
2. _____

E. List two things which give you a feeling of fatigue.

1. _____
2. _____

F. List two ways that you refresh yourself when you are tired.

1. _____
2. _____

G. On another paper, write a paragraph about dancers performing on a stage.

Use your new words.

Key Words

Name _____

loathe
uninterested
compromise

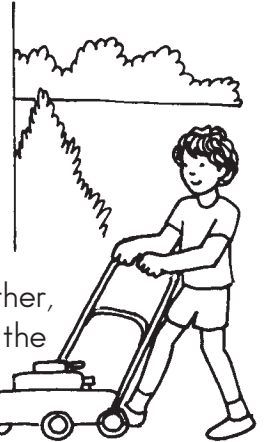

John had begun to loathe mowing the yard each Saturday morning. John's brother, however, was uninterested in his own chores of taking out the trash and making all the beds. To compromise, their mother suggested that they switch chores. John was glad to have a change, and his brother was happy to be outdoors.

A. Look up each word in a dictionary. Write a definition for each.

1. loathe _____
2. uninterested _____
3. compromise _____

B. Write the key word that fits with the meaning of each sentence.

1. _____ The kids did not care whether they went to a movie or played at home.
2. _____ Each girl gave in a little to settle the argument.
3. _____ Paul could not bear the thought of eating prunes.
4. _____ Sue paid no attention to the conversation around her.
5. _____ The man hated exercise.
6. _____ After much debate, everyone agreed to give in a little.

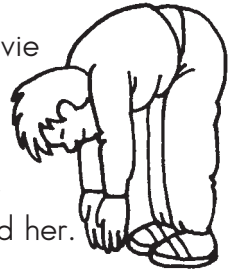

C. Check the synonyms for loathe.

- detest despise appreciate dislike oppose

D. Check the synonyms for uninterested.

- unconcern curiosity indifferent detachment inattention

E. Check the synonyms for compromise.

- arrangement settlement adjustment disagreement

F. Write a paragraph about planning a trip. Use your new words.

Key Words

Name _____

duplicate
carbon
collated

Joanie was writing a report for her history class. She needed to make a duplicate of each page as she wrote her report. The teacher wanted one copy and wanted Joanie to keep a copy for herself. Joanie used a carbon page behind her original page to make the copy. Finally, she collated the pages of the report and placed them into a folder.

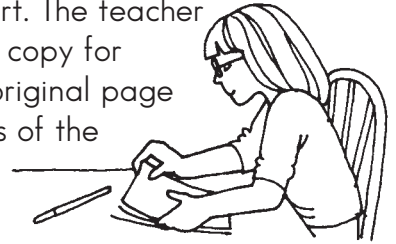

A. Look up each word in a dictionary. Write a definition for each.

1. duplicate _____
2. carbon _____
3. collated _____

B. Put a check by the sentence of each pair which uses the lesson word correctly.

1. The librarian used the machine to make a duplicate of her letter.
 The book's plot was duplicate as well as humorous.
2. The new toys were packed in a white, carbon box.
 The students bought a box of carbon paper to use.
3. The speaker collated the pages of his speech and stapled them together.
 The angry man collated the pages in disarray over the room.

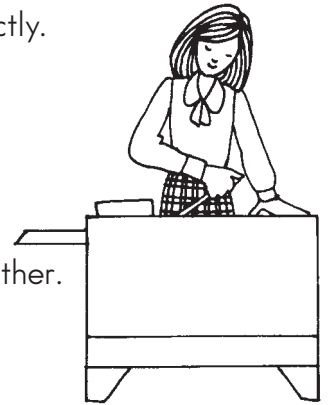

C. If you need a **duplicate** of something, you need

- an exact copy of something. a different version of something.

Name three ways to make a **duplicate**.

1. _____
2. _____
3. _____

D. Name three things of which you might make a **carbon** copy.

1. _____
2. _____
3. _____

E. If you **collated** a report, you would

- hand copy each page.
 put the pages in the correct order.

Circle the papers which are correctly collated.

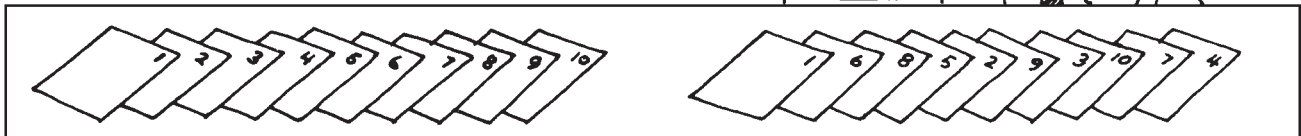

F. On another paper, write a paragraph about preparing a speech. Use your new words.

Key Words

Name _____

geometric
concentric
parallel

The art museum was featuring a modern art exhibit. One geometric painting was painted in black, white, and red colors. The middle of the canvas held concentric circles in red and white. The outer edges of the canvas were painted in parallel black lines.



A. Look up each word in a dictionary. Write a definition for each.

1. geometric _____
2. concentric _____
3. parallel _____

B. Underline the correct ending for each sentence.

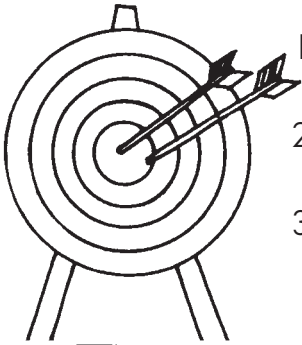

1. The building was decorated with bright, geometric paint.
bright, geometric designs.
2. The archery target was made of colored, concentric circles.
too concentric for the bow and arrow.
3. The rows of trees were planted parallel to the driveway.
were crooked and parallel by the driveway.

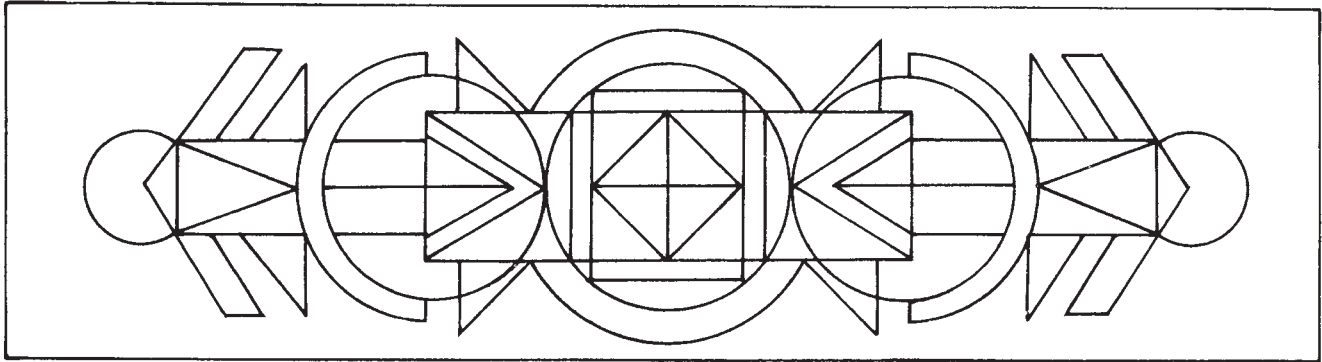

C. Check the words which could describe a **geometric** design.

- straight lines angles floral prints scenic curved lines

D. A **concentric** design has two straight lines together. has a common center.

E. Circle the example of **parallel** lines.

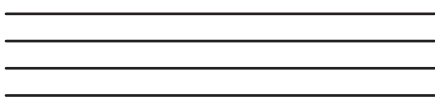

F. On another paper, write a paragraph about making a stage setting. Use your new words.

Key Words

Name _____

cluster
interval
intersperse

The gardener at the governor's mansion planted a cluster of spring flowers at the garden's entrance. He planted a row of rosebushes with a two-foot interval between each bush. Lastly, he planned to intersperse mint around the flowers.

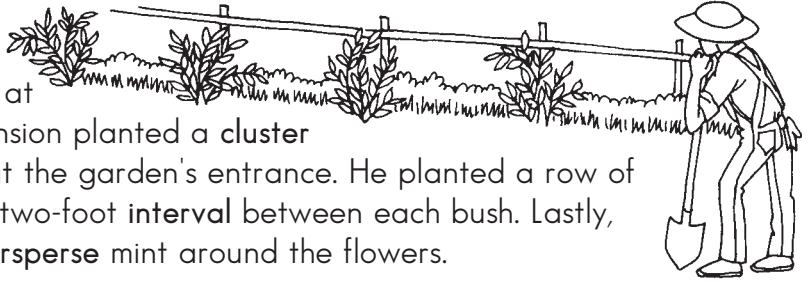

A. Look up each word in a dictionary. Write a definition for each.

1. cluster _____
2. interval _____
3. intersperse _____

B. Circle the phrase which describes the key word.

1. The people stood in a **cluster** around the museum exhibit.
a. grouped together b. in a straight line c. in groups of twos
2. There was an **interval** of thirty minutes between shows.
a. a third act of the play b. space in time c. an entertaining show
3. The speaker tried to **intersperse** jokes throughout his speech.
a. avoid telling any jokes b. tell four jokes c. scatter



C. Name four things which could be found in a **cluster**.

1. _____
2. _____
3. _____
4. _____

Circle the example of cluster.

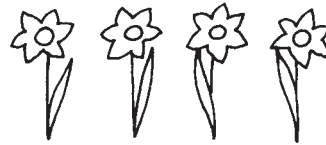

D. Give an example of

a space interval. _____

a time interval. _____

E. In the group of flowers, **intersperse** five butterflies.



Name two things that could be interspersed throughout a park.

1. _____
2. _____

F. On another paper, write a paragraph about a garden. Use your new words.

Key Words

Name _____

focus
reflected
image

The scientist began to focus his telescope on the faraway star. The telescope reflected and magnified the light from the star. The star's image was seen in the eyepiece of the telescope. From there, the scientist could focus clearly to record any changes in the star's shape.

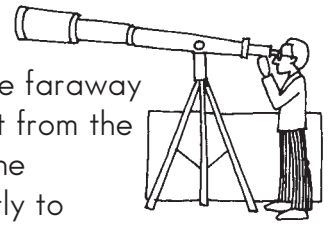

A. Look up each word in a dictionary. Write a definition for each.

1. focus _____
2. reflected _____
3. image _____

B. Rewrite each sentence. Replace the () words with key words.

1. The deer's image was (cast back) in the waters of the lake.

2. The photographer waited patiently for the tiger to come into (sharp view).

3. The curious baby studied her (self) in the mirror.

C. Circle the synonyms.

- | | | | | | | |
|--------------|------------|-----------|---------------|----------|----------------|-----------|
| 1. focus | center | blurry | to make clear | distant | sharpen | eyepiece |
| 2. reflected | returned | absorb | reproduced | cast | lens | projected |
| 3. image | reflection | different | double | likeness | representation | |

D. If something comes into focus, it becomes

- a sharp, clear, defined object.
- a distant, small, fuzzy image.



E. Name four things in which something can be reflected.

1. _____
2. _____
3. _____
4. _____

F. Name four ways in which a permanent image can be produced.

1. _____
2. _____
3. _____
4. _____

G. On another paper, write a paragraph about taking pictures of the ocean. Use your new words.

Key Words

Name _____

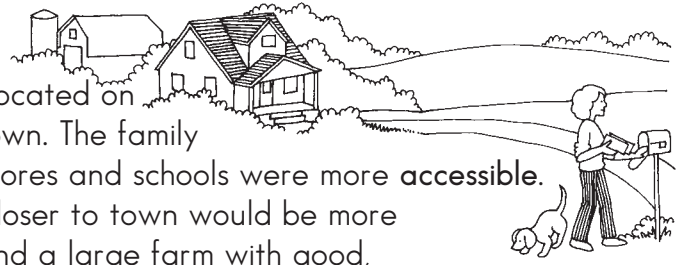

desolate
accessible
convenient

The Miller's farm was located on a desolate road far from town. The family wanted to live where the stores and schools were more accessible. They decided that a farm closer to town would be more convenient. They finally found a large farm with good, flat land just outside of town.

A. Look up each word in a dictionary. Write a definition for each.

1. desolate _____
2. accessible _____
3. convenient _____

B. Circle the phrase which describes each key word.

1. The desolate area had once been the sight of a small town.
a. near a source of water b. isolated and barren c. lush and fertile
2. The new highway made the resort more accessible to travelers.
a. longer to reach b. hard to reach c. easy to reach
3. Kim's mother took the most convenient route from her house to the store.
a. best for the purpose b. only for cars c. longest route

C. Write desolate or accessible by each phrase.

1. _____ an isolated, barren stretch of land
2. _____ a town library
3. _____ a neighborhood store
4. _____ an abandoned town
5. _____ a community center



D. List the names of two specific places which are

- desolate. 1. _____ 2. _____
- accessible. 1. _____ 2. _____

E. Name three things which make your life more convenient.

1. _____ 2. _____ 3. _____

F. On another paper, write a paragraph about buying a summer cottage. Use your new words.

Review

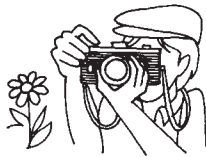

A. Number the words from 1 to 21 to put them in alphabetical order.

- | | | |
|--------------------|------------------|-------------------|
| _____ exhilaration | _____ duplicate | _____ cluster |
| _____ fatigue | _____ carbon | _____ interval |
| _____ refresh | _____ collated | _____ intersperse |
| _____ loathe | _____ geometric | _____ focus |
| _____ uninterested | _____ concentric | _____ reflected |
| _____ compromise | _____ parallel | _____ image |
| _____ desolate | _____ accessible | _____ convenient |

B. Match the words and definitions.

- | | |
|---------------------|--|
| 1. _____ parallel | a. a space between things, or a space in time |
| 2. _____ carbon | b. in the same direction; equal at all points |
| 3. _____ interval | c. to feel disgust, or intense dislike |
| 4. _____ accessible | d. the sharply defined condition of an image |
| 5. _____ fatigue | e. paper made of carbon chemical; used to copy |
| 6. _____ focus | f. weary from bodily or mental exertion |
| 7. _____ loathe | g. easy to approach, enter, or use |

C. Write a word on each line to replace the words in ().

concentric convenient duplicate intersperse refresh image uninterested

1. _____ The group stopped to (renew) themselves with lunch.
2. _____ Sam's father always carries a (copy) car key.
3. _____ The (circular) target is used for archery practice.
4. _____ Pat was (indifferent) about going to camp.
5. _____ The teacher asked Tom to (scatter) chairs among the tables.
6. _____ The actor studied his (likeness) in the mirror.
7. _____ The new supermarket is so (handy).

Review

- D. Choose the correct word to complete each sentence. Fill in the puzzle.
 reflected cluster exhilaration desolate duplicate collated geometric

Across

2. The animal's image was _____ in the pond.
4. The old log cabin was _____.
6. The books were _____ and bound in the factory.
7. The football team stood in a _____ around the coach.

Down

1. The swimmer's victory gave him a feeling of _____.
3. The librarian used the machine to make a _____ of her letter.
5. The company's sign featured a _____ design.

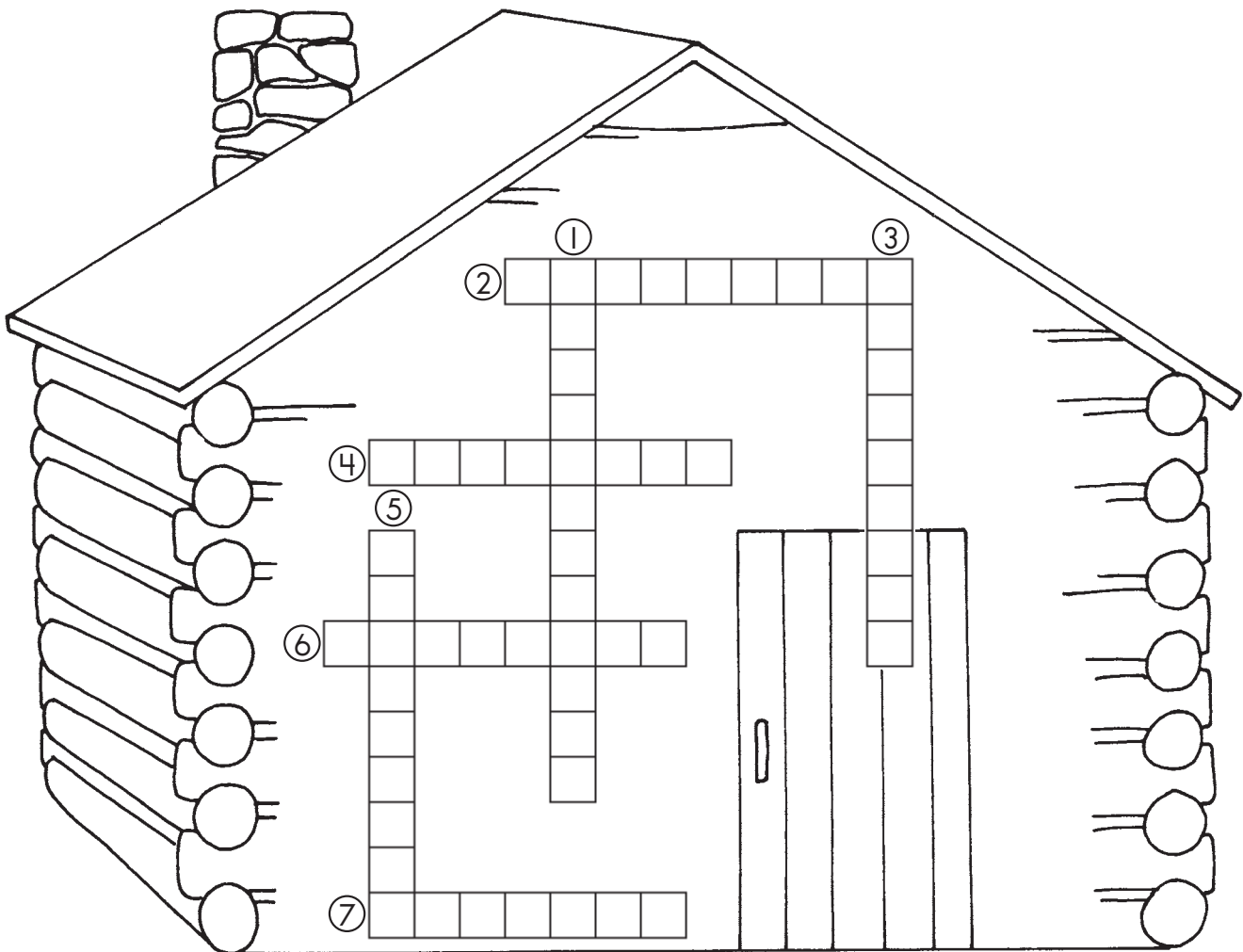

Answer Key

Note: For all letter A answers (except on Review pages), see glossary. Accept reasonable answer.

Page 1

- B. 1. mysterious 2. investigate
3. solution
- C. 1. puzzling, secret, strange, unexplainable; 2. research, inquire, examine, search;
3. unraveling, answer, explanation, finding

Page 2

- B. 1. top 2. bottom 3. top
- C. bright red
- D. creamy white
- E. dark blue

Page 3

- B. 1. c.
2. b.
3. a.
- C. 1. old-fashioned, classical, (quaint); 2. current, modern, recent;
3. selective, varied, combined
- E. contemporary: dress, sofa

Page 4

- B. 1. genuine 2. impostor 3. sincere
- C. 1. real, proven, true, actual
2. earnest, undisguised, honest, truthful
3. deceiver, pretender, fraud, faker
- D. 1. sincere 2. impostor 3. genuine

Page 5

- B. 1. Daydream out. Bungalow in.
2. Attend out. Reside in.
3. Occasion out. Mansion in.
- C. stately, enormous, impressive
- E. small, cozy, cottage, quaint

Page 6

- B. 1. dilapidated 2. dowdy 3. elegant
- C. 1. luxurious, refined, lovely, elaborate
2. unattractive, messy, unstylish, frumpy
3. crumbling, decayed, sagging, deteriorating
- D. dressed in luxurious, dressy outfit
- E. dressed in unstylish, messy outfit
- F. dilapidated: uninhabitable

Page 7

- B. 1. top 2. bottom 3. top
- C. 1. (assemble), collect, gather
2. possessions
3. scattered, distributed, spread
- E. auto, clothes, furniture

Page 8 Review

- A. 1. accumulate
2. acquisitions
3. antique
4. bungalow
5. contemporary
6. dilapidated
7. dispersed
8. dowdy
9. eclectic
10. elegant
11. genuine
12. impostor
13. indigo
14. investigate
15. ivory
16. mansion
17. mysterious
18. reside
19. scarlet
20. sincere
21. solution

- B. 1. d.
2. f.
3. a.
4. c.
5. b.
6. e
7. g

- C. 1. investigate
2. dowdy
3. indigo
4. genuine
5. bungalow
6. contemporary
7. acquisitions

Page 9 Review

- D. 1. mansion
2. dilapidated
3. scarlet
4. antique
5. solution
6. impostor
7. accumulate

Page 10

- B. 1. dignified 2. reasonable
3. absurd
- C. absurd: crazy, stupid, unreasonable, ridiculous
dignified: proud, grand, honorable, stately
reasonable: sensible, logical, fair, agreeable

Page 11

- B. 1. Letter out. Agility in.
2. Absent out. Flexible in.
3. Answer out. Ponderous in.
- C. 1. (coordinated), quick, active, nimble
2. bending, limber, elastic, supple
3. heavy, massive, weighty, cumbersome
- D. swimming, biking, skiing
- E. rubber, elastic, putty, clay

Page 12

- B. 1. antagonistic
2. reconcile
3. harmonious
4. antagonistic
5. harmonious
6. reconcile
- C. antagonistic: opposing, conflict, hostility
reconcile: apologize, correct, adjust
harmonious: agreement, harmony, cooperation
- D. ...antagonistic ...into harmonious...

Page 13

- B. 1. top 2. bottom 3. top
- C. unlimited, immeasurable, countless, continual
- D. limited, bounded, measurable, restricted
- E. tiny, immeasurably small

Page 14

- B. 1. b.
2. a.
3. c.
- C. 1. coiled 2. extended 3. extended
4. extended 5. coiled 6. coiled

Page 15

- B. 1. resemble 2. facsimile
3. diverse
- C. different, varying, dissimilar
- D. similar, alike, match
- E. reproduction, duplicate, pattern

Page 16

- B. 1. auditory
2. visual
3. verbal
4. visual
5. auditory
6. verbal
- C. across: visual, auditory, visual
auditory, visual, verbal
verbal, verbal, visual

Page 17

- B. 1. top 2. bottom 3. top
- C. capable of being read
- D. capable of being heard
- E. try to understand its meaning

Page 18 Review

- A. 1. absurd
2. agility
3. antagonistic
4. audible
5. auditory
6. coiled
7. decipher
8. dignified
9. diverse
10. extended
11. facsimile
12. finite
13. flexible
14. harmonious
15. infinite
16. infinitesimal
17. legible
18. ponderous
19. reasonable
20. reconcile
21. resemble
22. serpentine
23. verbal
24. visual
- B. 1. e
2. c.
3. a.
4. f.
5. b.
6. d.
7. h.
8. g.
- C. 1. serpentine
2. resemble
3. antagonistic

4. infinite
5. ponderous
6. reasonable
7. visual
8. legible

Page 19 Review**Across**

2. finite
3. harmonious
4. flexible
5. decipher
7. coiled

Down

1. dignified
4. facsimile
6. auditory

Page 20

- B. 1. fatigue 2. refresh 3. exhilaration
- C. exhilaration: elatedness, thrill, liveliness
fatigue: exhaustion, weariness, weakness
refresh: revive, renew, restore

Page 21

- B. 1. uninterested
2. compromise
3. loathe
4. uninterested
5. loathe
6. compromise
- C. detest, despise, dislike
- D. unconcern, indifferent, detachment, inattention
- E. settlement, adjustment

Page 22

- B. 1. top 2. bottom 3. top
- C. exact copy of something
- E. put pages in correct order correctly
collated: first set of papers

Page 23

- B. 1. bottom 2. top 3. top
- C. geometric: straight lines, angles, curves
- D. concentric: has a common center
- E. parallel: first set of lines

Page 24

- B. 1. a.
2. b.
3. c.
- C. cluster: first example circled

Page 25

- B. 1. reflected 2. focus 3. image
- C. 1. (center), to make clear, sharpen
2. returned, reproduced
3. reflection, (double), likeness,

representation

- D. sharp, clear, defined object

Page 26

- B. 1. b.
2. c.
3. a.
- C. 1. desolate
2. accessible
3. accessible
4. desolate
5. accessible

Page 27 Review

- A. 1. accessible
2. carbon
3. cluster
4. collated
5. compromise
6. concentric
7. convenient
8. desolate
9. duplicate
10. exhilaration
11. fatigue
12. focus
13. geometric
14. image
15. intersperse
16. interval
17. loathe
18. parallel
19. reflected
20. refresh
21. uninterested
- B. 1. b.
2. e.
3. a.
4. g.
5. f.
6. d.
7. c.
- C. 1. refresh
2. duplicate
3. concentric
4. uninterested
5. intersperse
6. image
7. convenient

Page 28 Review

- D. 1. exhilaration
2. reflected
3. duplicate
4. desolate
5. geometric
6. collated
7. cluster