

Sample Assignment Brief

AQA Level 3 Technical Level Design Engineering
Design Visualisation

Tutor/Assessor name			
Assignment Title			
Date assignment issued		Submission Date	

Task number	Grading criteria to be evidenced in the task
Task 1	P1, P2, P3, M1, M2
Task 2	P4, P5, P6, M3, D1
Task 3	P7, P8, P9, P10, P11, P12, M4, M5, M6, D2, D3
Task 4	P13, P14, M7, M8, D4, D5

Learner Authentication	
<p>I confirm that the work and/or the evidence I have submitted for this assignment is my own. I have referenced any sources in my evidence (such as websites, text books). I understand that if I don't do this, it will be considered as a deliberate deception and action will be taken.</p>	
Learner Signature	Date
 Tutor/Assessor Signature	 Date

WHO ARE PRACTICAL ACTION?

Practical Action is an international non-governmental organisation (NGO) that uses technology to challenge poverty in developing countries. It works with local communities to find practical solutions to the problems that they face. It primarily focuses on areas such as energy access, food and agriculture, urban waste, and water and disaster risk reduction. The organisation currently has over 100 projects in progress worldwide. Since 2012, over 3.2 million men and women living in developing countries have benefited from access to technology that has improved their lives.

Many of the projects undertaken by Practical Action involve engineering activities. For example, to increase income and access to food for women, the elderly and other vulnerable groups. Projects have included natural 'zeer pot' refrigeration systems designed to keep food cool, fish cages that allow people in Bangladesh to grow fish in local ponds and floating gardens that can assist in the growing of food on normally flooded land. Rainwater harvesting technologies, such as soil ridges and water storage tanks, result in improved access to water for both drinking and irrigation purposes.



A storage tank designed to hold drinking water



Farmers installing a new treadle pump

It is extremely difficult to grow food in parts of the world where rainfall is sparse and erratic. In such climates the land is simply too dehydrated to be of any use, resulting in people struggling to feed even their own families, let alone grow food to sell. Irrigation systems such as drip systems and treadle pumps are used to tackle this issue. Able to be operated by one or two adults, a treadle pump uses pedal power to suck water up from wells up to 7.5m deep in the ground at a rate of up to 18m³ per hour; that is about six times more water than can be drawn from a traditional hand pump. It can be operated by just two people and is less tiring to use than a hand pump. A treadle pump also brings money into the local economy, through the use of locally manufactured parts.

TASK OVERVIEW

You have been asked to design a treadle pump for use in remote areas. You will need to carry out concept development to produce visual design solutions. You must use CAD software to create a 3D model of the treadle pump that can be shared with potential sponsors who will fund the manufacture and the engineers who will work locally to produce it.



A treadle pump in use in Nepal

TREADLE PUMP DESIGN

Task 1: PO1 - Carry out engineering design concept development (P1, P2, P3 M1, M2)

In this task you will evaluate the areas that need to be considered during the design process.

You will need to:

- Outline areas for consideration in the design process for the treadle pump. These design considerations could include amongst others, but not be limited to the capabilities of the CAD system. For example, materials and manufacturing processes to be used, ergonomics and statutory responsibilities under health, safety and environmental legislation.
- Develop and present concept ideas using engineering drawing techniques to present solutions.

Your evidence must include:

- An outline of the design considerations for the treadle pump from the supplied design brief.
- Concept designs and annotated sketches to BS8888 standard showing orthographic and isometric views for the treadle pump reflecting the considerations identified and described previously from the design brief and using appropriate methods to communicate your design ideas including rendering where appropriate.

You could also:

- Explain how CAD can be used in design concept development.
- Produce sketches which are rendered to show depth and contours of design.

Task 2: PO2 - Plan for the use of 3D Parametric CAD systems in Engineering Design (P4, P5, P6, M3, D1)

You have been tasked with recommending a suitable system to enable successful modelling of the design on a 3D Parametric CAD system and justify why this design should be undertaken on such a package in preference to a traditional CAD system.

You will need to:

- Research 3D Parametric CAD systems including their advantages and disadvantages over traditional CAD systems. The research should include, but not be limited to, hardware and software requirements and how design information can be stored.
- Plan how the chosen system will be used to produce the design.

Your evidence must include:

- A specification for a suitable 3D parametric CAD system that will be used to model the treadle pump. This should include:
 - Hardware requirements.
 - Software Requirements.
 - How design information will be stored.
- A 3D parametric CAD plan showing how the recommended system will be used to produce the design. This should include:
 - Working procedures for how the system will be operated
 - Instructions for safe working.

- A comparison of using 3D Parametric CAD systems over traditional CAD systems, explaining the advantages and disadvantages of each and links with other software.
- An explanation of how 3D parametric CAD will be used in the design, including a justification of the choice of presentation and an evaluation into the benefits of integrating 3D Parametric CAD into the manufacturing process.

You could also:

- Explain how 3D parametric CAD will be used in the design with justification as to choices of presentation.
- Evaluate the benefits of integrating 3D parametric CAD designs into manufacturing processes (with reference to specific manufacturing processes or methods).

Task 3: PO3 - Produce 3D Parametric Models (P7, P8, P9, P10, P11, P12, M4, M5, M6, D2, D3)

The recommendations made in task 2 have been implemented. You now have to produce the 3D parametric model of the treadle pump.

You will need to:

- Plan the requirements to fully model the treadle pump.
- Undertake production of the 3D parametric model for the treadle pump.
- Research how the model can be manipulated.
- Investigate suitable ways in which the virtual model can be saved and retrieved.

Your evidence must include:

- A description of the purpose of the 3D model of the treadle pump design.
- A 3D Parametric model using an appropriate coordinate system, with reasons for its selection, and content libraries where required and that shows:
 - Parts.
 - working assemblies.
 - exploded assemblies.
- 2D assembly and exploded view drawings taken from the model that comply with BS8888, showing the parts for manufacture and the assembled treadle pump.
- A procedure outlining how the model can be saved for future retrieval and demonstration that this procedure has been followed.

You could also:

- Produce 3D exploded assemblies that demonstrate assembly/disassembly processes.

Your evidence could also include:

- Alternative designs using modelled parts and content libraries, clearly considering the assembly and manufacturing requirements including, but not limited to, geometrical dimensioning and tolerancing (GD&T).

Task 4: PO4 - Apply rendering and animation to engineering designs using CAD (P13, P14, M7, M8, D4, D5)

Modelling is being used more and more in the design process to minimise waste when items go into production. However, this increasingly needs models to appear realistic and be animated to check both operation and performance. In this task you will undertake activities to make the model of the treadle pump come to life.

You will need to:

- Investigate suitable ways in which the virtual model can be made to look realistic via rendering and animation, taking into consideration items such as, but not limited to:
 - Required finish.
 - System capabilities.
 - Production constraints.
 - Environmental settings.
- Undertake rendering of the models to enhance realism.
- Animate the model to assess operation and performance.

Your evidence could also include:

- A rendered 3D model to achieve the required degree of realism, that may take into account environmental settings including lighting, material textures and camera angles.
- Animated models to demonstrate the full assembly and disassembly process for the treadle pump.

You could also:

- Produce animations that show advanced mechanical functionality and adjustment of environmental settings.

Submission Checklist (please insert the items the learner should hand in)	Confirm submission
Outline of the design considerations for the treadle pump	
Concept designs and annotated sketches to BS8888 standard	
Specification for a suitable 3D parametric CAD system that will be used to model the treadle pump	
3D parametric CAD plan	
Comparison of using 3D Parametric CAD systems over traditional CAD systems	
Explanation of how 3D parametric CAD will be used in the design	
Description of the purpose of the 3D model of the treadle pump design	
3D Parametric model	
2D assembly and exploded view drawings	
Rendered 3D model	
Animated models	
Learner - please confirm that you have proofread your submission	

ADDITIONAL NOTES FOR TEACHERS

Treadle pumps:

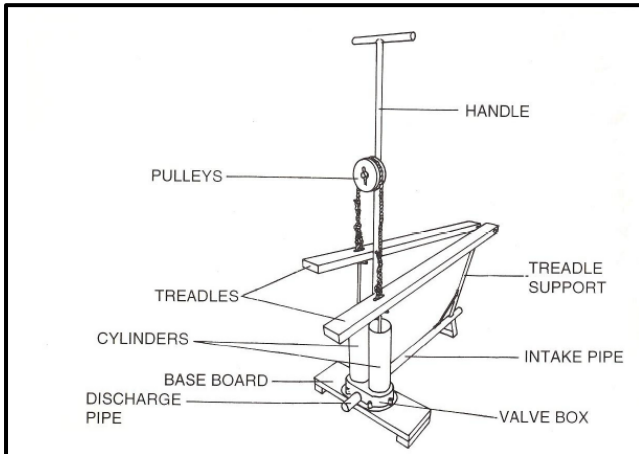

Treadle pump design

A treadle pump is a human-powered low-cost pump designed to lift shallow water sources for irrigation. A treadle is a lever device pressed by the foot to drive a machine, in this case a pump. The treadle pump can do most of the work of a motorized pump, but costs considerably less to purchase. As it needs no fossil fuel (it is driven by the operator's body weight and leg muscles), it can also cost less to operate than a motorized pump. Because leg muscles tire less than arm muscles, it can also be used by the farmers for longer. The treadle pump can greatly increase the income that farmers generate from their land, both by extending the traditional growing season and by expanding the types of crops that can be cultivated.

The treadle pump can draw water from up to 7.5m below the surface and has a maximum flow rate of 18m³ per hour. These are very approximate, and should only be taken as a rough guide. As the lift height increases, flow rate falls so at a maximum lift, the actual flow rate will be much less than the maximum flow rate. Low-cost treadle pumps have been developed in Nepal, under the guidance of Practical Action. Most of the parts are manufactured locally, so it also brings much needed income to the local economy. The equipment is basically developed for irrigation of small land area (2000-3000m²) where home labour is easily available.

The pump mechanism has two cylinders with piston and check valve assemblies. The treadle action creates alternate strokes in the two pistons that lift the water in pulses. Using twin cylinders means that the water output is semi-continuous, making the treadle pump more efficient than a single cylinder pump such as a hand pump.

The following web links provide useful technical information and additional context for this assessment:

Case studies and the use and impact of treadle pump technology:

<http://practicalaction.org/irrigation-4>

<http://practicalaction.org/treadlepump>

<http://practicalaction.org/treadle-pump-1>

<http://practicalaction.org/treadle-pump-2>

<http://practicalaction.org/treadle-pump-video>

