

SA2

						-	
--	--	--	--	--	--	---	--

**SINGAPORE CHINESE GIRLS' SCHOOL**

**PRELIMINARY EXAMINATION 2004**

Name : \_\_\_\_\_ ( )

Date : \_\_\_\_\_

Class : Primary 6

**SCIENCE**

**BOOKLET A**

30 questions

60 marks

Total Time For Booklets A & B : 1 h 45 min

**DO NOT OPEN THIS BOOKLET UNTIL YOU ARE TOLD TO DO SO.**

**FOLLOW ALL INSTRUCTIONS CAREFULLY.**



3 Study the flow chart carefully.

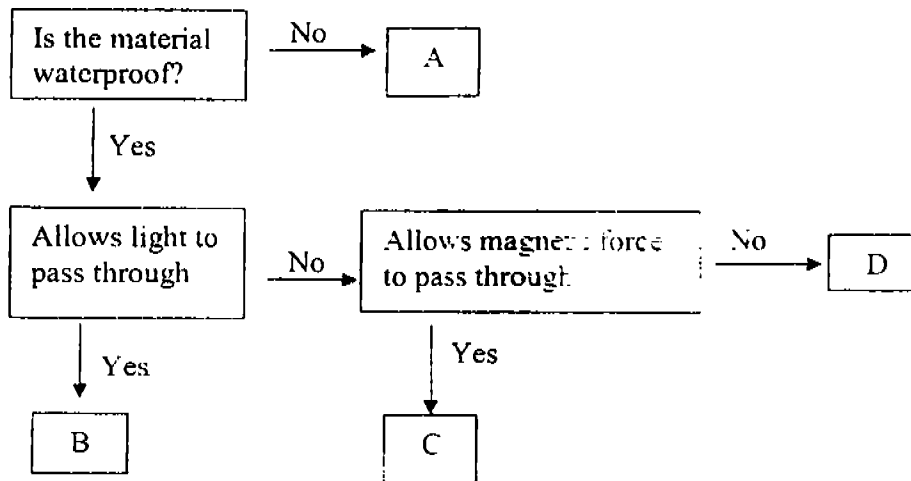

What could material A, B, C and D be?

	A	B	C	D
1)	Cloth	Aluminium	Steel	Glass
2)	Cloth	Glass	Aluminium	Steel
3)	Steel	Aluminium	Glass	Cloth
4)	Wood	Plastic	Steel	Iron

4 Jim discovers that when a nail sticks to a magnet, it too becomes a magnet. He set up the experiment below. X and Y repel each other.

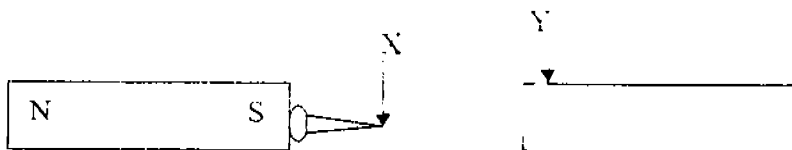

What is the correct naming of the poles at X and Y?

	X	Y
1)	north	south
2)	north	north
3)	south	south
4)	south	north

5

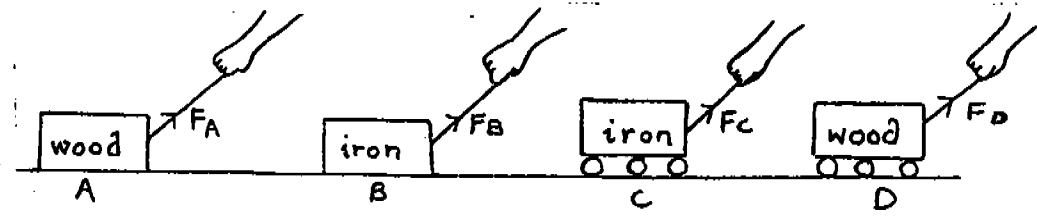

The 4 blocks shown above are of the same size. A true statement is \_\_\_\_\_.

- 1) Force D is less than Force C
- 2) C would require the least force to move
- 3) A and D would require the same force to move
- 4) Force C is more than Force D but less than Force A

6

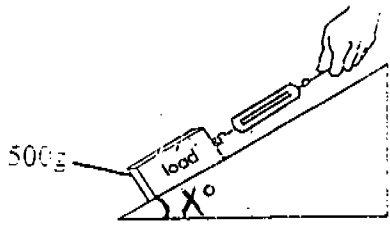

A 500g load was pulled up a ramp using a spring balance as shown in the diagram above. The force was then measured. The experiment was then repeated but the angle of inclination ( $X^\circ$ ) was increased by  $5^\circ$  each time. Which one of the following graphs shows the results of the experiment?

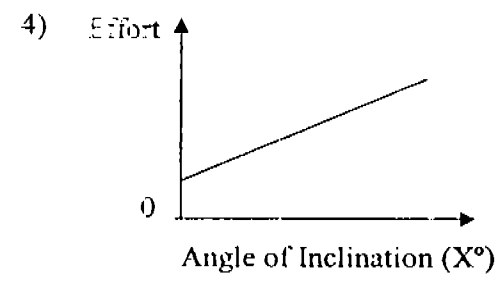
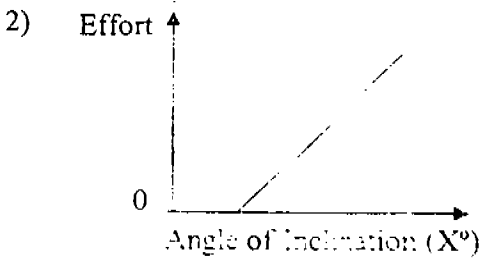
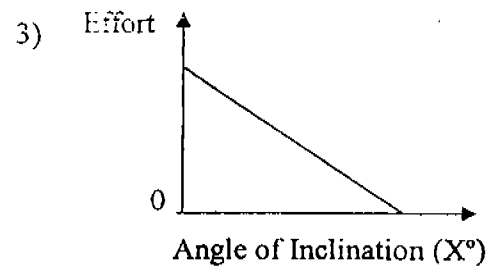
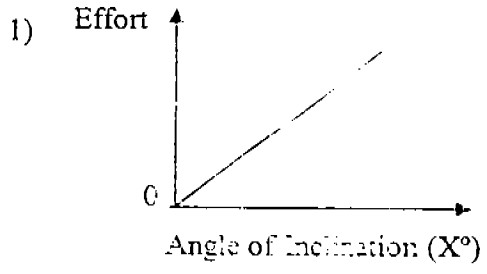

- 7 Below is a cross-section of a pond. The places in the pond where the plants are found are A, B, C and D.

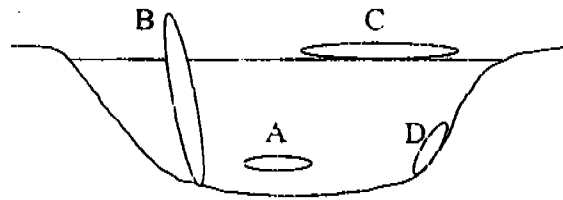

Which one of the following correctly indicates a plant that can be found at each place?

	A	B	C	D
1.	hydrilla	sedge	mosquito fern	tape grass
2.	cabomba	cattail	water hyacinth	arrowhead
3.	water banana	lotus	water lettuce	algae
4.	water gentian	water lily	water moss fern	elodea

- 8 Which one of the following correctly shows the classification of Earth's natural resources?

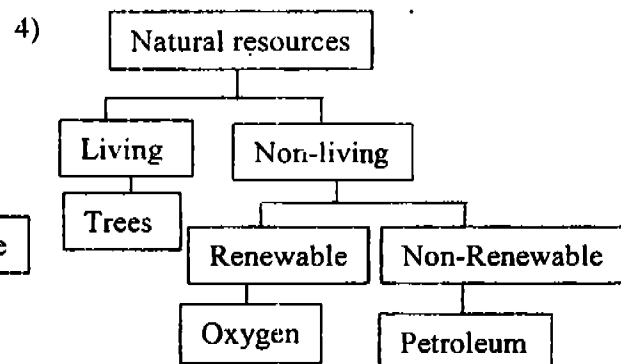
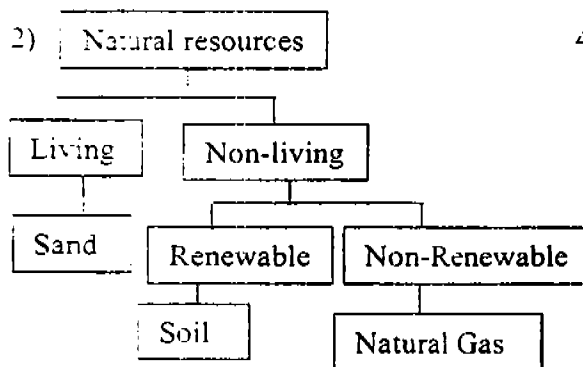
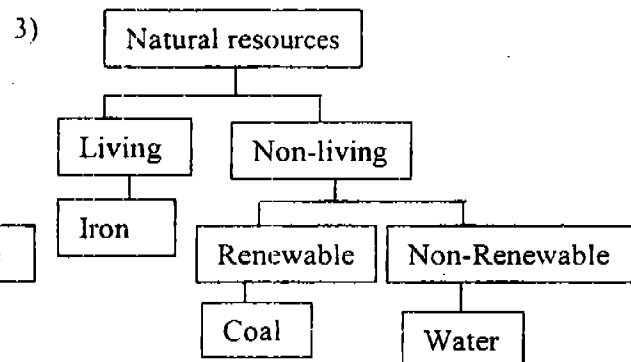
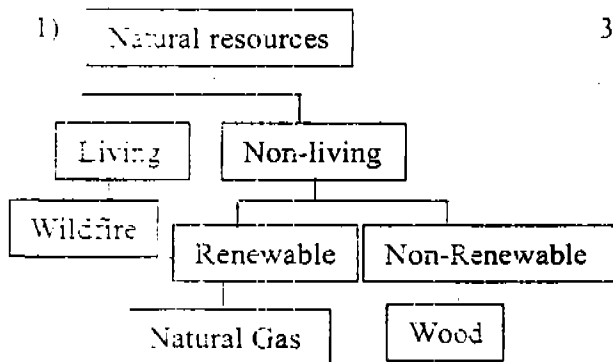

9. Tom set up the experiment shown below to find out whether woodlice prefer conditions that are dark and wet. He placed 15 woodlice in the middle of each tube.

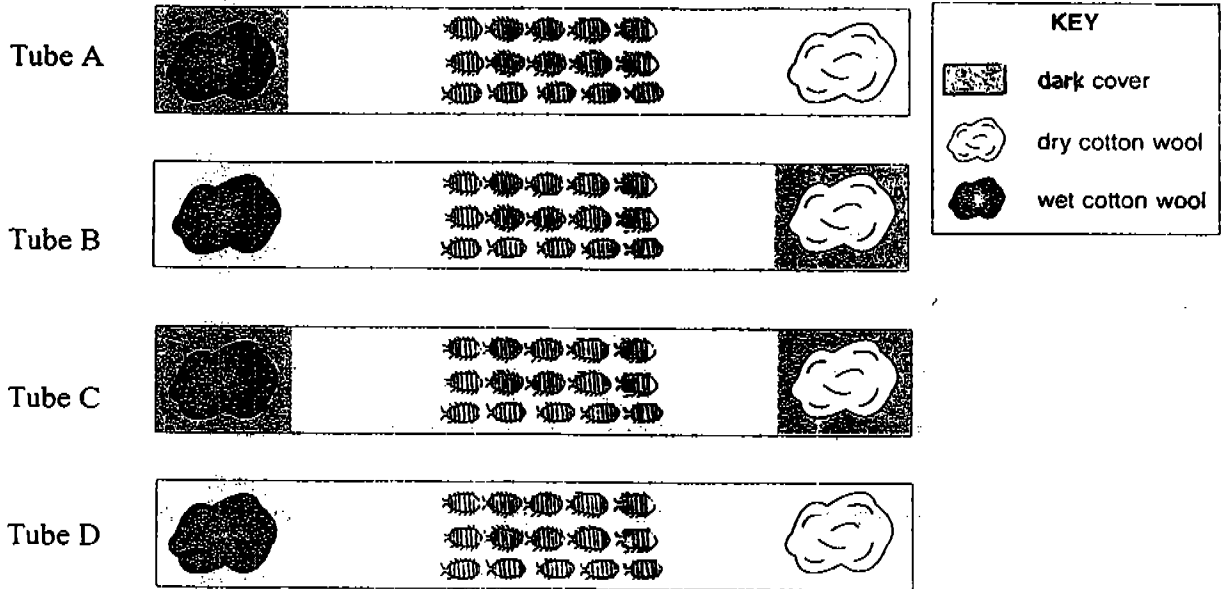

After a while, the number of woodlice that had moved to each end was counted. Which results show that woodlice prefer dark and wet conditions?

1)

Tube	Number of woodlice	
	Wet	Dry
A	5	10
B	7	8
C	4	11
D	9	6

3)

Tube	Number of woodlice	
	Wet	Dry
A	10	5
B	8	7
C	11	4
D	9	6

2)

Tube	Number of woodlice	
	Wet	Dry
A	7	8
B	7	8
C	6	9
D	9	6

4)

Tube	Number of woodlice	
	Wet	Dry
A	10	5
B	6	9
C	5	10
D	5	10

10 Study the food web below.

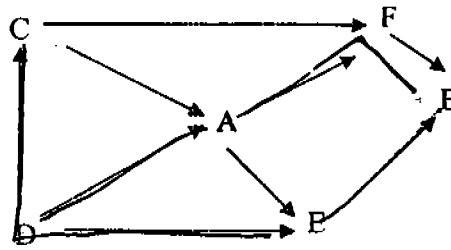

How many food chains can be found in the food web?

- 1) 4
- 2) 5
- 3) 6
- 4) 7

11 There are 7 frogs, 24 grasshoppers, 2 pythons and 6 snails in a tank. Which one of the following shows the most likely numbers of each of them after one day?

	Frog	Grasshopper	Python	Snail
1)	3	6	2	6
2)	4	24	2	5
3)	5	14	2	4
4)	7	12	1	4

12 Study the diagrams below carefully. These birds have special features to enable them to look for food.

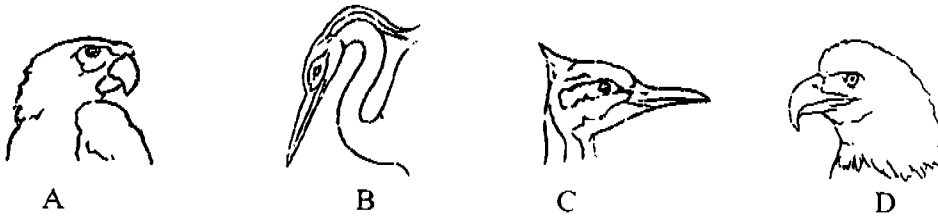

What types of food do the 4 birds, A, B, C and D eat?

	Bird A	Bird B	Bird C	Bird D
1)	Seeds	Shrimps	Insects	Other animals
2)	Insects	Fish	Seeds	Other animals
3)	Insects	Other animals	Nectar	Shrimps
4)	Other animals	Nectar	Fish	Seeds

- 13 The classification table below shows how some plants with weak stems are adapted for climbing to get maximum sunlight.

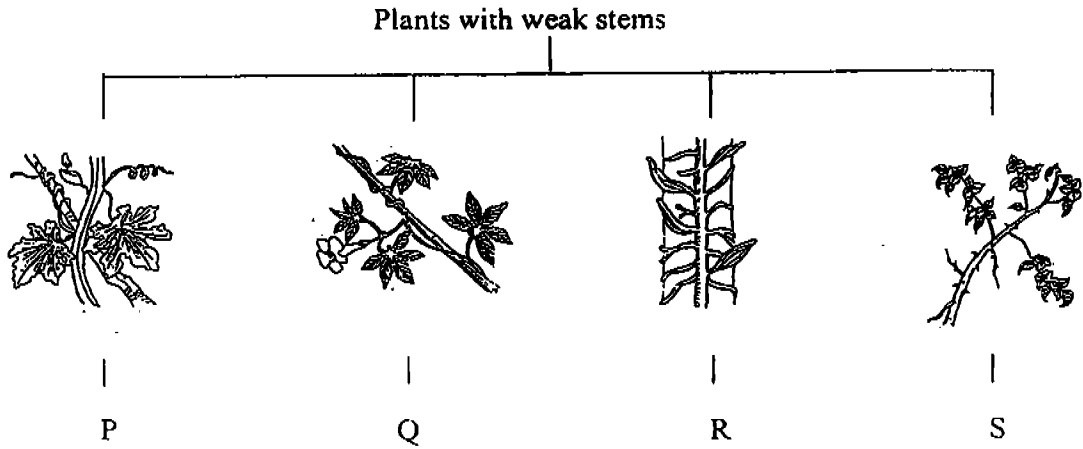

Which one of the following can be put in P, Q, R and S respectively?

	P	Q	R	S
1)	pepper	blue pea	carpet grass	water melon
2)	pumpkin	maiden's jealousy	money plant	Rattan palm
3)	passion flower	bean plant	sweet potato	rose
4)	Honolulu creeper	strawberry	ivy	mimosa

- 14 What are the advantages of genetically modified organisms?

- A: Drought-resistant plants  
 B: Plants susceptible to diseases  
 C: Produce plants with a high yield  
 D: Improve the quality of food from modified plants

- 1) A and B only                      3) A, C and D only  
 2) C and D only                      4) A, B, C and D only



15 The diagram below shows the life cycle of a butterfly.

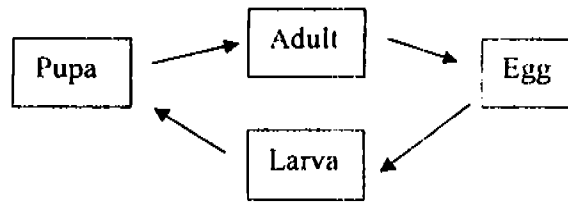

Which one of the following groups of animals has a similar life cycle as the butterfly?

- 1) Hen, frog, cockroach
- 2) Moth, mosquito, dragonfly
- 3) Bee, housefly, mealworm beetle
- 4) Dragonfly, cockroach, grasshopper

16 Amy crushed a ping pong ball and it became dented. However, no air escaped while she was doing it. This experiment shows that air \_\_\_\_\_.

- A: takes up space  
B: can be compressed  
C: has no definite shape  
D: has no definite volume

- 1) B only
- 2) B and C only
- 3) B, C and D only
- 4) All the above

17 If objects, A, B and C form the Lunar Eclipse, which object is likely to represent planet Earth?

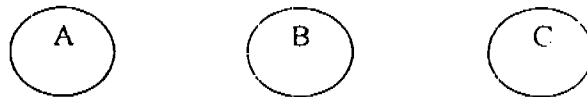

- 1) A only
- 2) B only
- 3) C only
- 4) All are possible

18 Observe the following picture.



The above cell cannot make its own food because \_\_\_\_\_.

- A: it does not have a regular shape
- B: the cell membrane is present
- C: the cell contains cytoplasm
- D: it does not contain chloroplasts

- 1) D only
- 2) B and C only
- 3) A, B and C only
- 4) All the above

19 The animals below are grouped according to where the eggs are fertilized.

Internal Fertilisation	External Fertilisation
Rabbit	Frogs
Ostrich	Salmon
Crocodile	Catfish

Which one of the following animals fertilise their eggs externally?

- 1) Snake
- 2) Turtle
- 3) Penguin
- 4) Salamander

20 Identify the parts of the body where digestive juice can be found.

- A) gullet
- B) mouth
- C) stomach
- D) small intestine
- E) large intestine

- 1) A only
- 2) A, B and C
- 3) B, C and D
- 4) All of the above

21 Oxygen can enter our body through our nose. Which part of the plant allows carbon dioxide to enter the plant?

- 1) stem
- 2) buds
- 3) leaves
- 4) flowers

22 Observe the diagram.

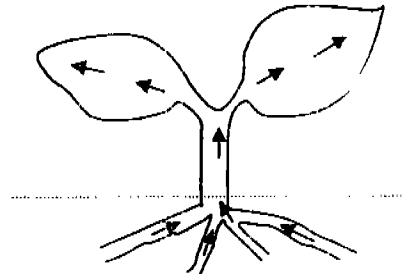

The arrows in the diagram show the movement of \_\_\_\_\_ to all parts of the plant.

- |          |                   |
|----------|-------------------|
| 1) food  | 3) oxygen         |
| 2) water | 4) carbon dioxide |

23 Which of the following statements are true?

- A Blood rich in oxygen leaves the lungs and flows to the heart.
- B The heart pumps blood rich in carbon dioxide back to the lungs.
- C The veins that run from all parts of the body to the heart carry blood rich in oxygen.
- D The veins that run from all parts of the body carry blood rich in carbon dioxide to the heart.

- |                 |                    |
|-----------------|--------------------|
| 1) A and B only | 3) C and D only    |
| 2) B and C only | 4) A, B and D only |

24 In the circuit below, which bulb/s will remain lighted when bulb D fuses?

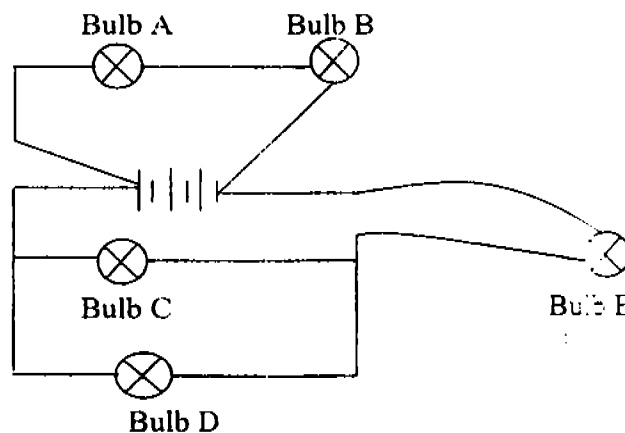

- |                    |                                    |
|--------------------|------------------------------------|
| 1) A only          | 3) A, B, C and E only              |
| 2) A, B and C only | 4) None of the bulbs will light up |

25 Observe the circuit below.

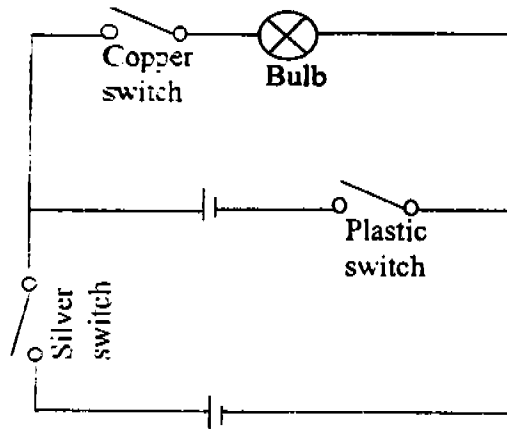

The bulb will light up when \_\_\_\_\_ switches is/are closed.

- 1) silver only
- 2) copper only
- 3) copper and silver only
- 4) copper, plastic and silver

26

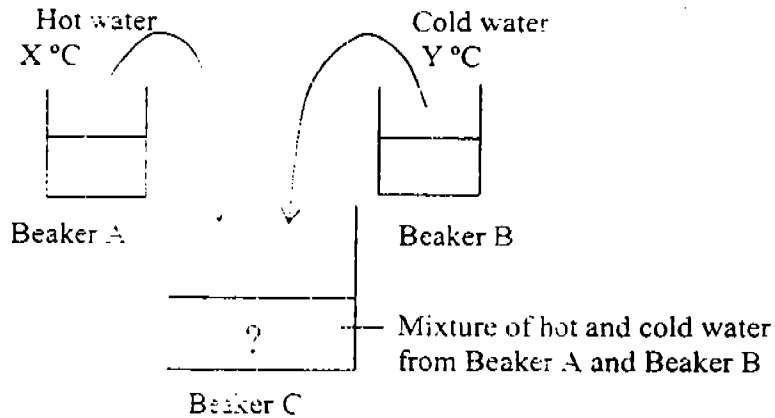

Beaker A and Beaker B contain equal amounts of water. When the water in Beaker A and Beaker B is poured into Beaker C, the temperature of the water in Beaker C will be \_\_\_\_\_.

- 1) less than  $Y\text{ }^{\circ}\text{C}$
- 2) more than  $X\text{ }^{\circ}\text{C}$
- 3) more than  $X\text{ }^{\circ}\text{C}$  and less than  $Y\text{ }^{\circ}\text{C}$
- 4) more than  $Y\text{ }^{\circ}\text{C}$  and less than  $X\text{ }^{\circ}\text{C}$

27



When does the reaction process shown above take place?

- 1) All the time
- 2) Only during the day
- 3) In the absence of light
- 4) In the presence of light

28 The diagram shows five possible pathways for the transfer of energy from green plants to Man. Which pathway transfers the most energy to Man?

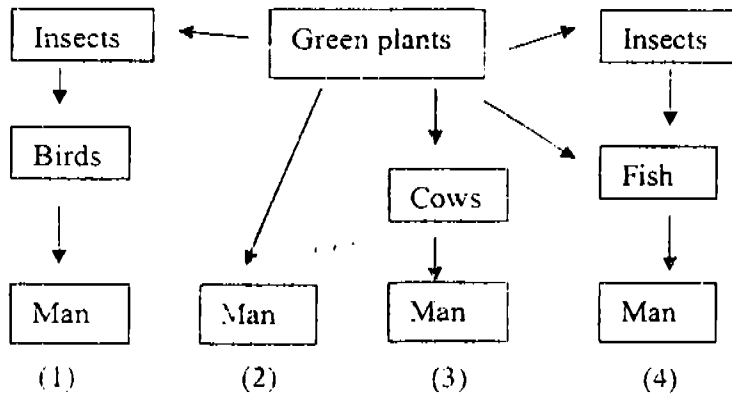

29

Group X	Group Y	Group Z
Fan	Doorbell	Computer monitor

The objects above are classified according to the forms of energy they produced when in use. Which of the following objects can be placed in Groups X, Y and Z?

	Group X	Group Y	Group Z
1)	Lamp	Cake mixer	Rice Cooker
2)	Electric drill	Radio	Lamp
3)	Cake mixer	Lamp	Electric typewriter
4)	Electric iron	Telephone	Television

30

renewable, pollution free

Which of the following energy source satisfy all the above conditions?

- A Fossil Fuels
- B Tidal energy
- C Nuclear energy
- D Geothermal energy

- 1) A and C
- 2) B and D
- 3) C and D
- 4) B, C and D

						—	
--	--	--	--	--	--	---	--

**SINGAPORE CHINESE GIRLS' SCHOOL  
PRELIMINARY EXAMINATION 2004**

Name : \_\_\_\_\_ ( )

Date : \_\_\_\_\_

Class : Primary 6

Parent's Signature  .....
---------------------------------

**SCIENCE  
BOOKLET B**

16 questions

40 marks

Total Time For Booklets A & B : 1 h 45 min

**DO NOT OPEN THIS BOOKLET UNTIL YOU ARE TOLD TO DO SO.**

**FOLLOW ALL INSTRUCTIONS CAREFULLY.**

	Marks Obtained	Max. Possible Marks
Booklet A		60
Booklet B		40
Total		100

Name : \_\_\_\_\_ ( ) Class : Primary 6

**PART II (40 marks)**

Write your answers to questions 31 to 46 in this booklet.

31 The table below shows how some materials have been classified based on certain property.

GROUP A	GROUP B
Silver	Steel
Copper	Cobalt
Aluminium	Nickel
i)	ii)

a) List down one suitable heading for the two groups. (1)

Group A: \_\_\_\_\_ Group B: \_\_\_\_\_

b) Give another example of a material under Group A and Group B. Fill in the answer in the table above. (1)

32

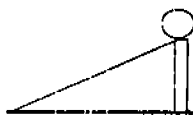

Tim released a ball from the top of a slope and measured the time it took to reach the bottom. He carried out the experiment on 4 different surfaces. He repeated the experiment 4 times on each surface. The following table shows his results.

Surface	1 <sup>st</sup> Reading	2 <sup>nd</sup> Reading	3 <sup>rd</sup> Reading	4 <sup>th</sup> Reading
W	15	15	17	15
X	16	15	13	14
Y	26	25	24	27
Z	29	30	32	31

a) On which surface did the ball travel the fastest? (1)

\_\_\_\_\_

b) Give one reason why Tim carried out the experiment 4 times for each surface. (1)

\_\_\_\_\_

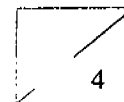



33 a) Study the diagrams below carefully.

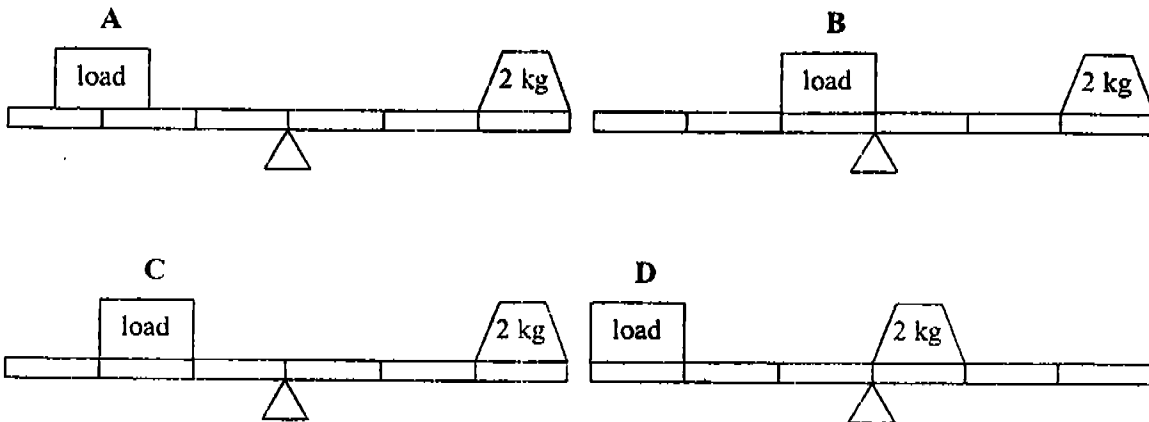

Arrange the masses of the loads in **ascending order**. Write the letters in the boxes provided. (1)

--	--	--	--

b) The set of scales shown below is balanced.

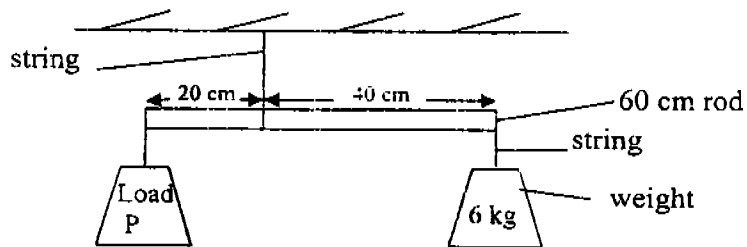

The mass of Load P is \_\_\_\_\_ (1)

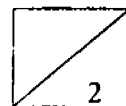

34

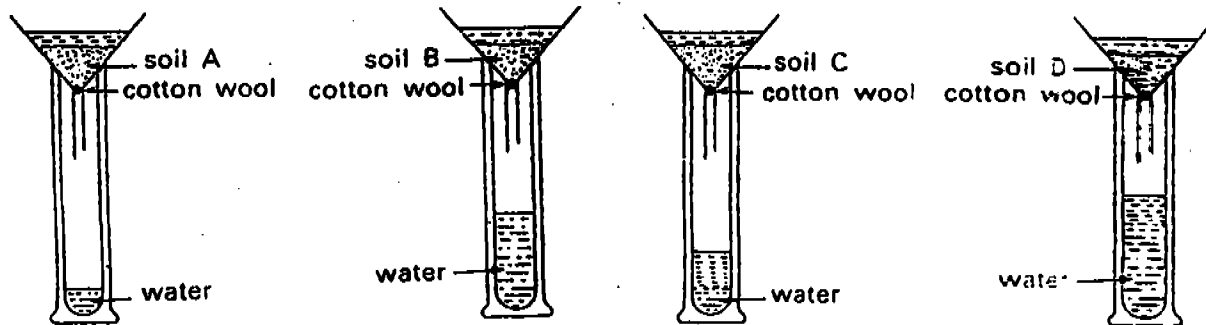

An equal amount of water is added to 4 funnels which contain the same amount of soil. The amount of water collected in each case is shown above.

a) Which soil absorbs the most water? (1)

\_\_\_\_\_

b) What is the relationship between the air spaces in the soil and the amount of water collected? (2)

\_\_\_\_\_  
\_\_\_\_\_

c) Which soil is most suitable for a plant which grows well in a dry and sandy habitat? (1)

\_\_\_\_\_

35 The picture below shows a kangaroo. Some of the features are labelled.

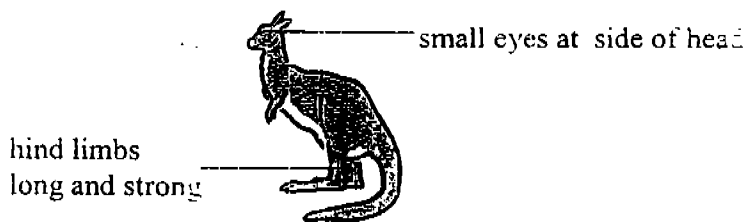

Complete the table below by explaining how each of the features of the kangaroo helps it to survive. (2)

Feature	How This Helps The Kangaroo
a) Small eyes at the side of its head	
b) Long and strong hind legs	

- 36 Foxes eat rabbits. The following graph shows the changes in the populations of foxes and rabbits in Habitat X over a three-year period.

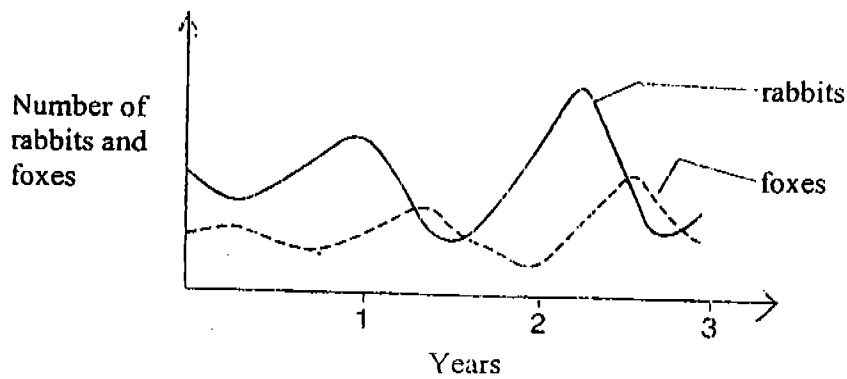

- a) Explain why an increase in the number of rabbits is followed by an increase in the number of foxes. (1)
- \_\_\_\_\_
- \_\_\_\_\_
- b) Explain why the increases in the fox population do not happen at exactly the same time as increases in the rabbit population. (1)
- \_\_\_\_\_
- \_\_\_\_\_
- c) Explain why decreases in the fox population do not happen at exactly the same time as decreases in the rabbit population. (1)
- \_\_\_\_\_
- \_\_\_\_\_

- 37 The table below shows the height of a plant over 5 weeks.

Week	1	2	3	4	5
Height(cm)	3	6	12	7	4

- a) What do you think was happening to the plant at week 5? (1)
- \_\_\_\_\_
- \_\_\_\_\_

37

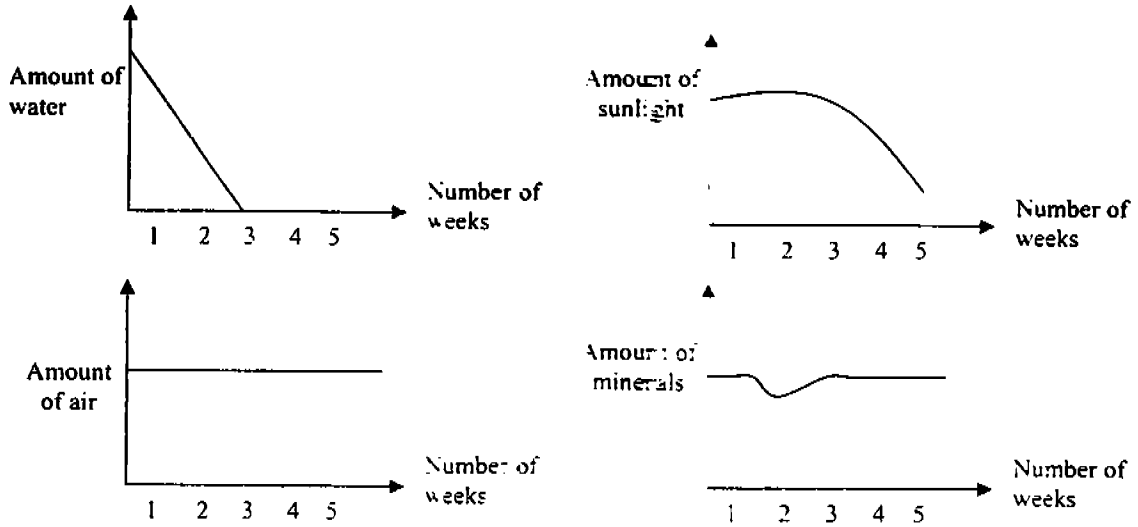

b) Based on the information given above what do you think caused the height of the plant to decrease? (2)

---



---

38 The table below contains information on some planets.

Planet	Distance from the Sun (million km)	Time taken to orbit the Sun (days)
Mercury	58	88
Venus	108	225
Earth	150	365
Mars	228	687
Jupiter	778	4380
Saturn	1425	10950
Uranus	2867	30660
Neptune	4497	60225
Pluto	5914	90885

a) Based on the information in the table, give one possible reason why there are no living things on Pluto? (2)

---

b) How many revolutions would Earth make around the Sun in the time Uranus takes to make one revolution? (2)

---

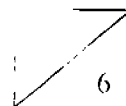

39 Study the classification chart.

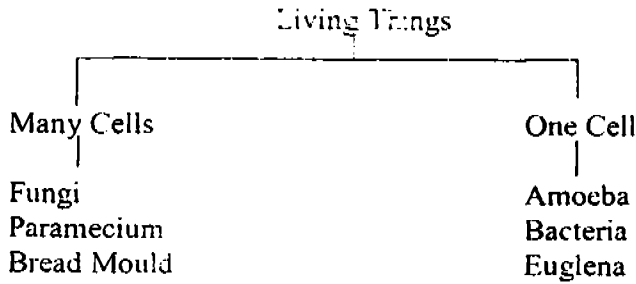

a) One of the organisms in the diagram has been classified wrongly. Identify the organism. (1)

\_\_\_\_\_

b) Name another organism that has only one cell. (1)

\_\_\_\_\_

40

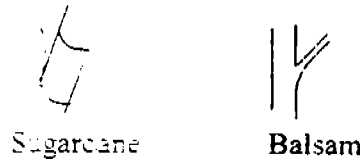

Mother cut off part of the sugarcane stem and balsam stem as shown in the diagram. She removed the roots and leaves of each plant. She planted them side-by-side in the ground. For two weeks, she watered both plants and nourished them with nutrients.

a) What will happen to both the plants? (1)

\_\_\_\_\_

b) Give a reason to your answer. (1)

\_\_\_\_\_

\_\_\_\_\_

41 May has to choose a suitable method to cultivate a fruit tree which takes at least 8 years for the tree to bear flowers. The method she chooses has to preserve the sweetness of the parent plant.

a) Suggest one method she can use to propagate the tree quickly. (1)

\_\_\_\_\_

b) Suggest another plant that can be propagated by the same method as the one mentioned in 41a. (1)

\_\_\_\_\_

42 Study the graph below. It shows the pulse rate (number of heartbeats per min) of a girl involved in different activities.

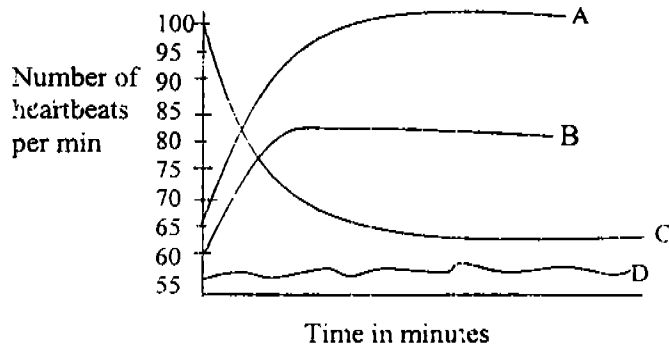

a) Which line most likely represents the heartbeat of the girl running a 100m race? (1)

\_\_\_\_\_

b) Which line most likely represents the heartbeat of the girl cooling down from the race? (1)

\_\_\_\_\_

c) Looking at line D, what do you think the girl is doing? (1)

\_\_\_\_\_

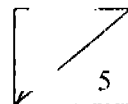

43 Study the diagram carefully.

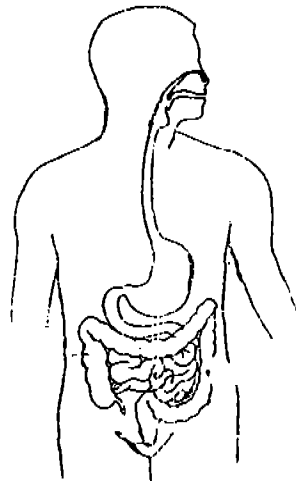

a) Identify the part where food is digested and passed into the blood vessels. (1)

\_\_\_\_\_

b) David complains of constipation. Draw an arrow to show where undigested food is stored. (1)

44 Observe the circuit shown on the right carefully.

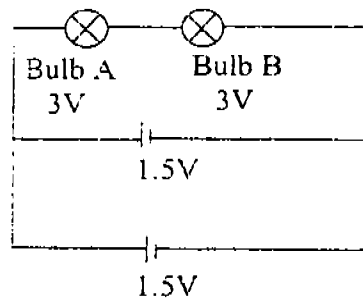

a) If you are allowed to change one thing in the circuit, what would you change in order to maximize the brightness of Bulb A? (1)

\_\_\_\_\_

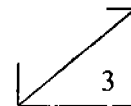

- 44 b) Draw your new circuit in the box below. (1)

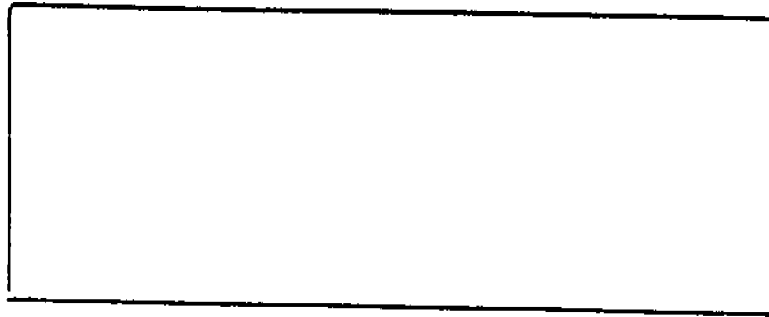

45

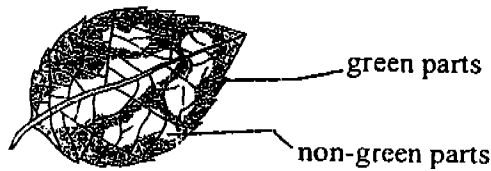

James plucked a leaf from a variegated plant which had been kept in bright sunlight for 3 days.

- a) Name the substance in the leaf required for photosynthesis. (1)

\_\_\_\_\_

- b) In which part of the above leaf is the substance identified in (a) present? (1)

\_\_\_\_\_

- c) What happens when iodine solution is added to the decolourized leaf of the above plant? (1)

\_\_\_\_\_

\_\_\_\_\_

- 46 State the energy conversion that takes place in each of the following cases:

- a. Launching of a space shuttle (1)

\_\_\_\_\_

- b. Generation of electric energy in nuclear power stations (1)

\_\_\_\_\_

\_\_\_\_\_



SINGAPORE CHINESE GIRLS SCHOOL  
PRELIMINARY EXAMINATION 2004  
PRIMARY 6  
SCIENCE

SAL

01. 2	11. 1	21. 3
02. 1	12. 1	22. 2
03. (2)	13. (2)	23. 4
04. 3	14. (3)	24. 3
05. (1)	15. 3	25. 3
06. 4	16. (3)	26. 4
07. (1)	17. (2)	27. (1)
08. 4	18. 1	28. (2)
09. 3	19. 4	29. (2)
10. 3	20. 3	30. 2

31) a) non-magnetic                      Magnetic

b) i) gold                                  ii) iron

32) a) Surface X

b) To confirm the results of the experiment.

33) a) D    A    C    B

b) 12 kg

34) a) Soil A

b) When the air spaces in the soil increases the amount of water collected also increases.

c) Soil D

35) a) Allow it to see its surroundings to look out for predators

b) Help it jump and escape quickly.

36) a) If the number of rabbits increases, there would be more food for the fox to eat and so, it increases.

b) There is an interval of time before youngs can be born.

c) Foxes do not die from the lack of food.

37) a) The plants have wilted and was dying.

b) There was not enough water and sunlight so the height of plant decreased.

38) a) Pluto is furthest away from the sun so there is no heat or light there.

b) 34

39) a) Paramecium

b) Yeast

40) a) Balsam will die while sugarcane will grow into a new plant.

b) Sugarcane can propagate from stem cutting but balsam cannot.

41) a) Cut part of the stem and plant it.

b) Rose

42) a) A

b) C

c) Sleeping

43) a) Small intestine

b)



44) a) Arrangement of batteries

b)

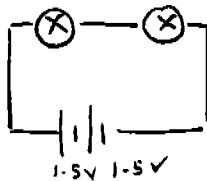

45) a) Chlorophyll

b) Green parts

c) Iodine on green parts turn dark blue. Iodine on non-green parts remain unchanged.

46) a) potential energy ---- kinetic energy ----- heat + light + sound energy.

b) potential energy ---- heat energy ---- kinetic energy --- electrical energy