

福建会馆属下五校小六统一考试 (一)

道南 • 爱同 • 崇福 • 南侨 • 光华

HOKIEN HUAY KUAN 5-SCHOOL PRIMARY 6  
COMBINED PRELIMINARY EXAMINATION (I)

TAO NAN • AI TONG • CHONGFU • NAN CHLAU • KONG HWA

572



NOTE:

1. Do not open this booklet until you are told to do so;
2. Follow carefully the instructions given at the beginning of each section of the booklet.
3. Do not waste time. If a question is difficult for you, go on to the next one.

Total time: 1h 45min

School : \_\_\_\_\_

Name : \_\_\_\_\_

Class : \_\_\_\_\_

Date : \_\_\_\_\_

Section A (30 x 2 marks)

For each question from 1 to 30, four options are given. One of them is the correct answer. Make your choice (1,2,3 or 4). Shade the correct oval (1,2,3 or 4) on the Optical Answer Sheet.

1. The diagram below shows a system of four gears, A, B, C and D.

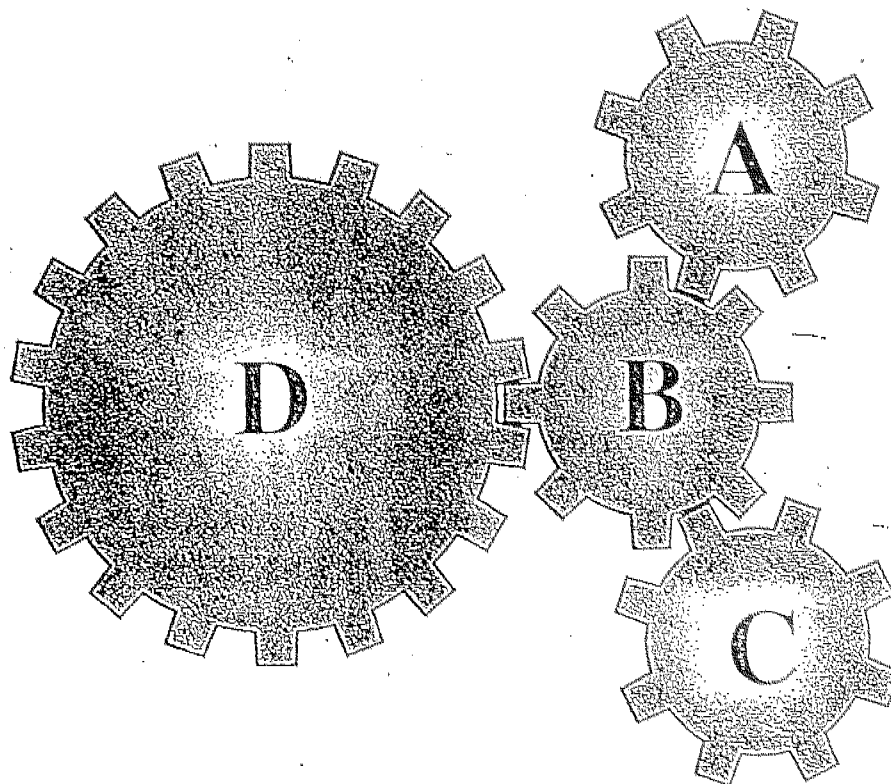

If gear A spins clockwise, which way do the other gears spin?

|     | Gear B         | Gear C         | Gear D         |
|-----|----------------|----------------|----------------|
| (1) | Anti-clockwise | Clockwise      | Anti-clockwise |
| (2) | Anti-clockwise | Clockwise      | Clockwise      |
| (3) | Clockwise      | Anti-clockwise | Clockwise      |
| (4) | Clockwise      | Anti-clockwise | Anti-clockwise |

2. A spring 15 cm extends to 17 cm when Load X is suspended on it, and 21 cm when Load Y is suspended on it. If Load X is 5g, what is the total mass of Load X and Y?

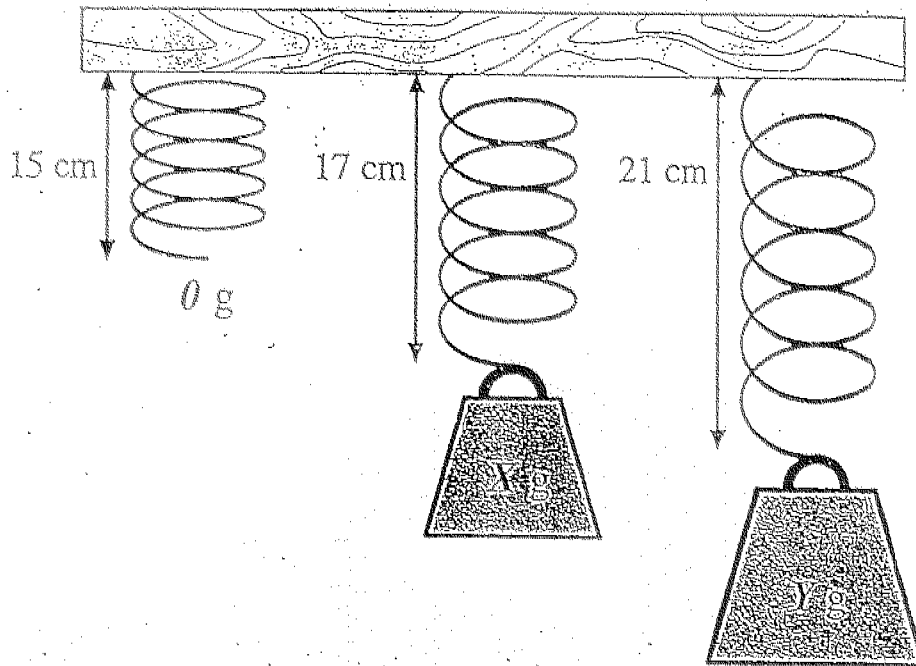

- (1) 5 g
- (2) 10 g
- (3) 15 g
- (4) 20 g

3. The table shows how fruits can be grouped.

|            | A few seeds | Many Seeds |
|------------|-------------|------------|
| Thin skin  | A           | B          |
| Thick skin | C           | D          |

In which box, A, B, C or D, would you place jackfruit?

- (1) A
  - (2) B
  - (3) C
  - (4) D
4. The graph below shows how the temperature of two beakers of water, X and Y, changes over time.

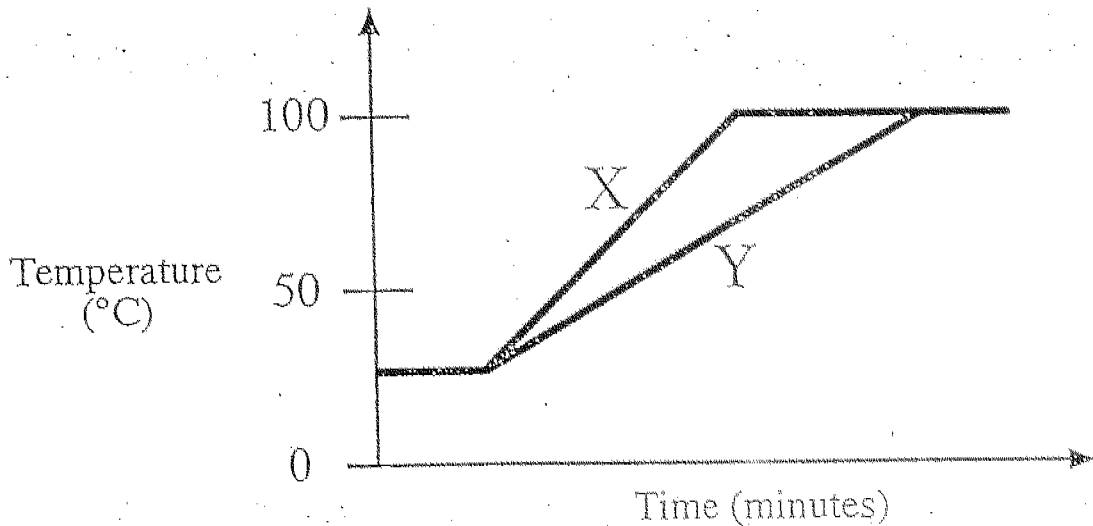

Study the graph above carefully. Which one of the following statements interprets the graph correctly?

- (1) There were ice cubes in Beakers X and Y.
- (2) Both beakers of water boiled at the same time.
- (3) Beaker X was heated over a stronger flame than Beaker Y.
- (4) Beaker Y was heated over a stronger flame than Beaker X.

5. Mike had a glass tank containing some earthworms, dead leaves and maize seeds. He added another animal into the tank. He observed the tank for a few hours. Then he drew a graph to show his observations.

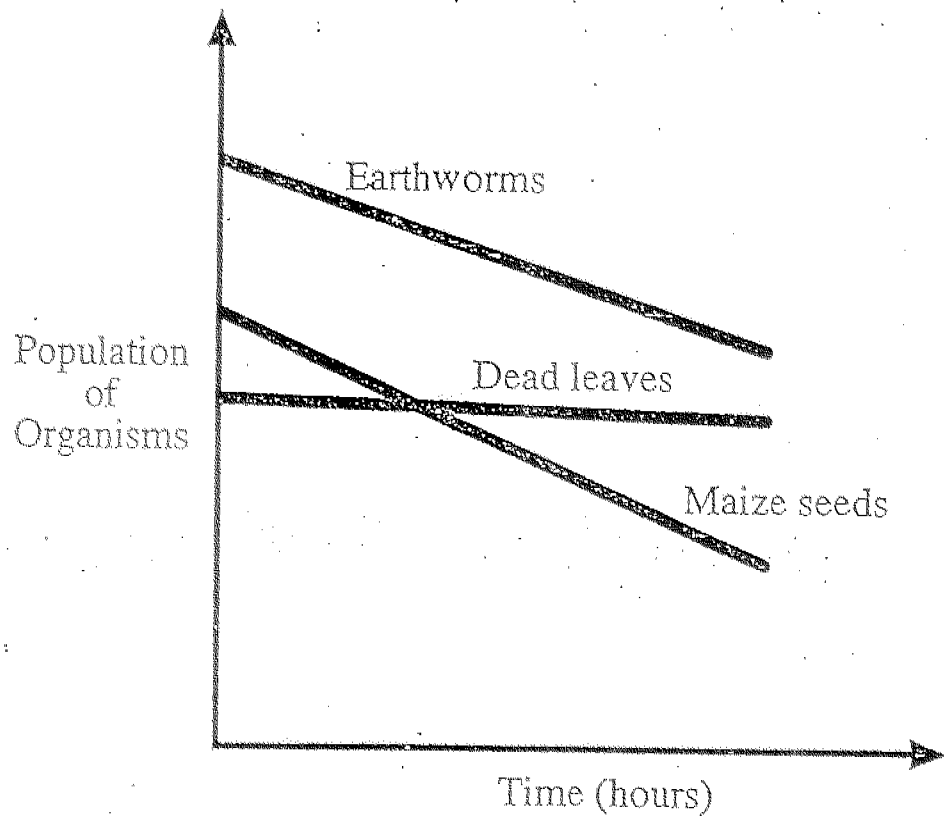

By looking at the graph, we can tell that the animal that Mike put in was a \_\_\_\_\_.

- (1) snail
- (2) chick
- (3) toad
- (4) grasshopper

6. The diagram shows the Wong family tree.

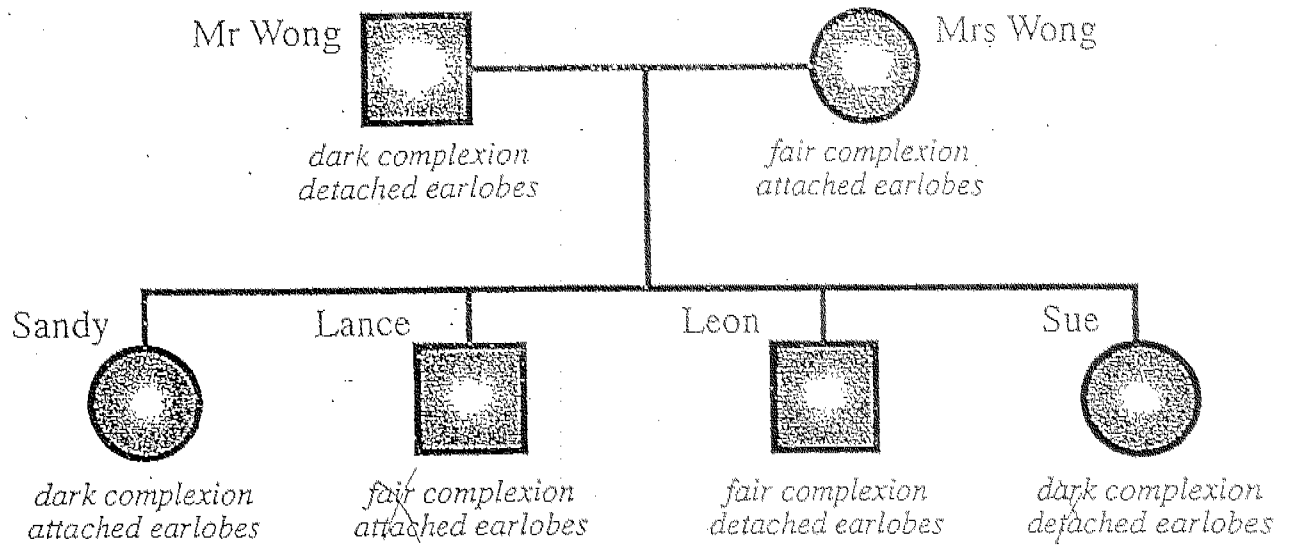

Which of the children inherited one feature only from each parent?

- (1) Sandy and Sue only
- (2) Lance and Leon only
- (3) Lance and Sue only
- (4) Sandy and Leon only

7. Jane set up an experiment as shown below. The set ups were left in two different places from 1 p.m. to 4 p.m.

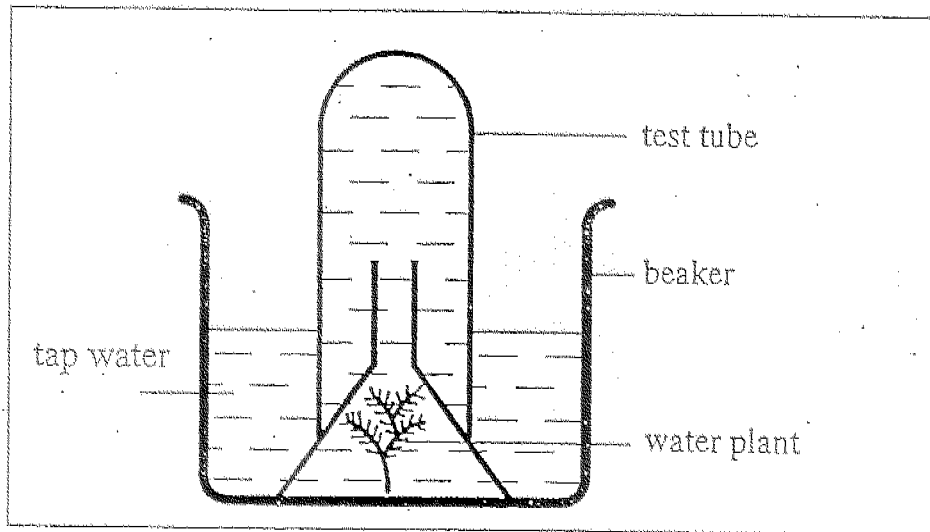

Placed in a dark wooden cupboard

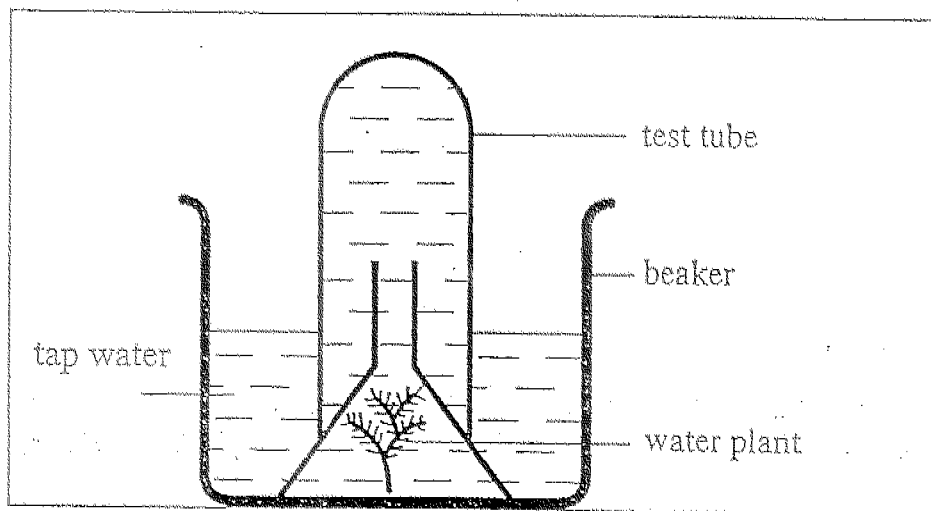

Placed in the field

She used this experiment to find out if \_\_\_\_\_.

- (1) respiration needs sunlight
- (2) photosynthesis needs sunlight
- (3) the amount of light affects decomposition
- (4) the temperature affects the rate of photosynthesis

8. Which one of the following diagrams correctly shows the growth of a plant with fertilisation taking place at the correct stage?

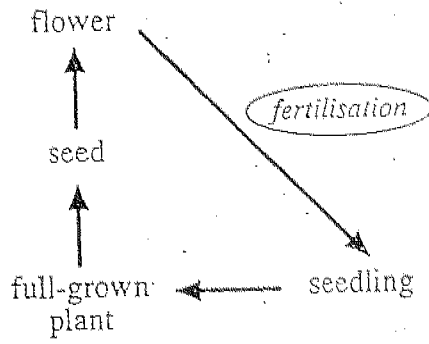

(1)

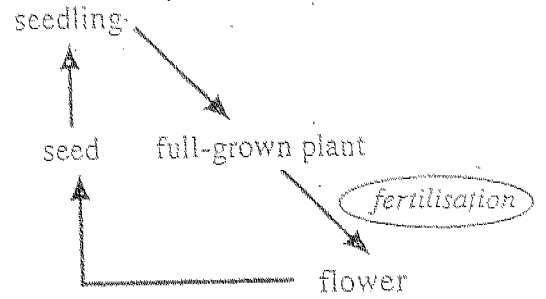

(2)

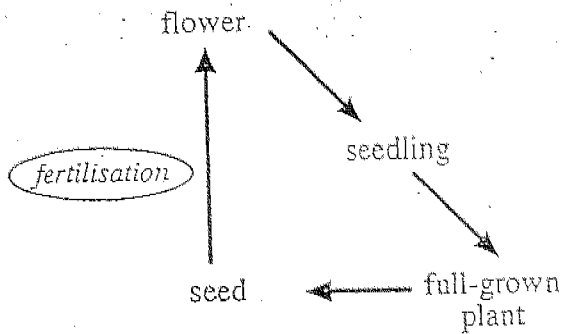

(3)

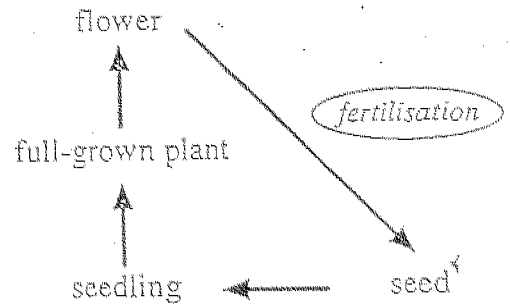

(4)



9. The circulatory system carries blood containing the gases, oxygen and carbon dioxide, through blood vessels in the body. The diagram shows the parts of the circulatory system.

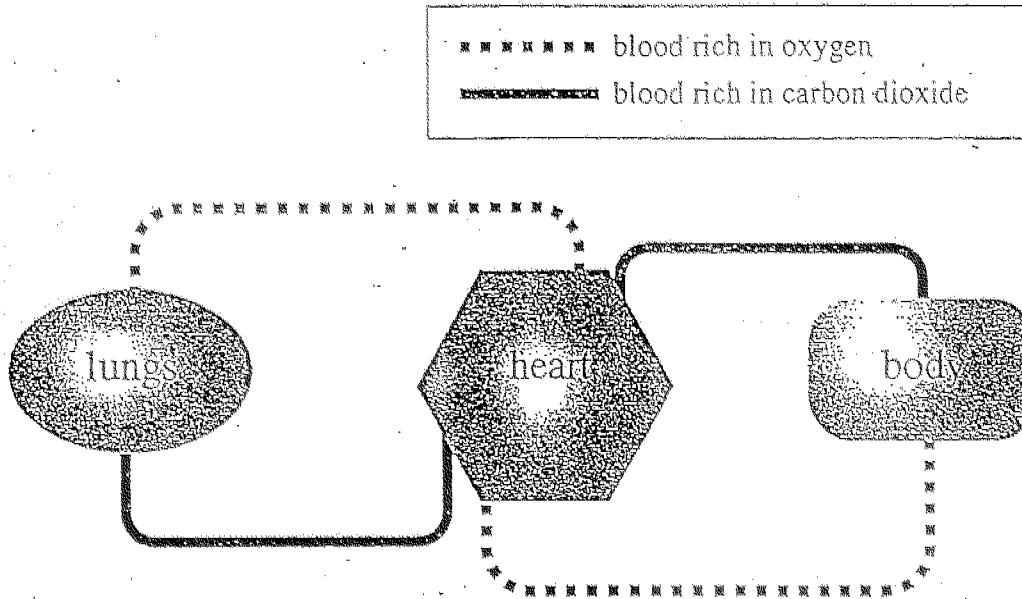

Which one of the diagrams correctly shows the direction in which blood flows?

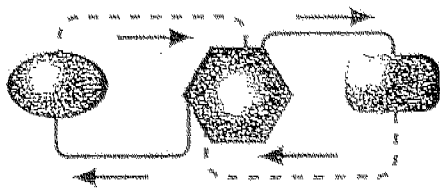

(1)

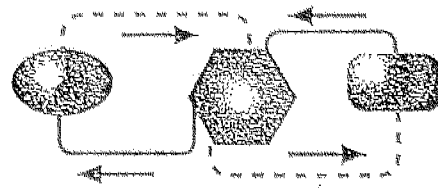

(2)

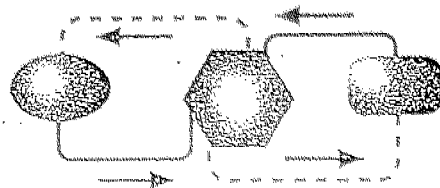

(3)

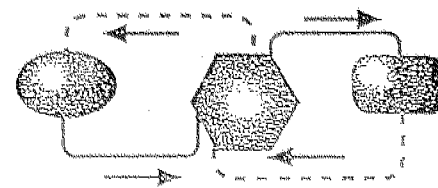

(4)

10. The map shows seven factories, T, U, V, W, X, Y and Z, along a river system and the types of aquatic animals, A, B, C and D found there. The arrows show the direction the rivers flow.

Hot water discharged from some factories increases the water temperature of the river nearby.

Aquatic animals A and B are found in areas where the water temperature is lower.  
Aquatic animals C and D are found in areas where the water temperature is higher.

The diagram shows where aquatic animals A, B, C and D can be found.

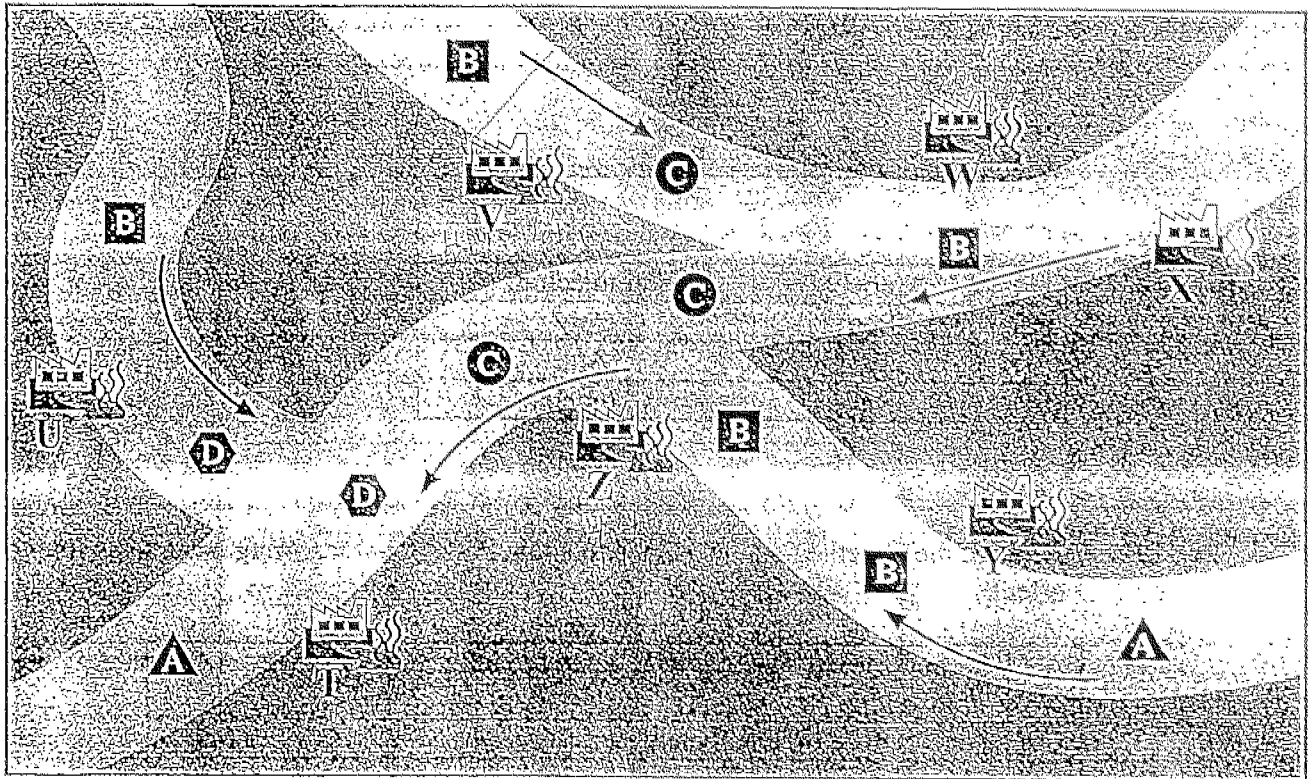

#### KEY

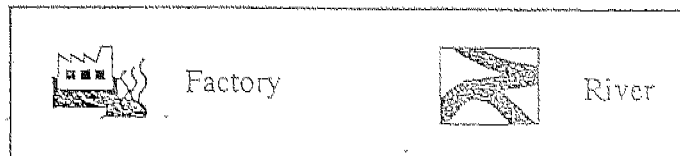

Which factories are most likely to be discharging hot water into this river system?

- (1) T, W and X only
- (2) U, V and Z only
- (3) V, Y and Z only
- (4) W, X and Y only

11. The classification diagram below shows the headings for two groups of organisms.

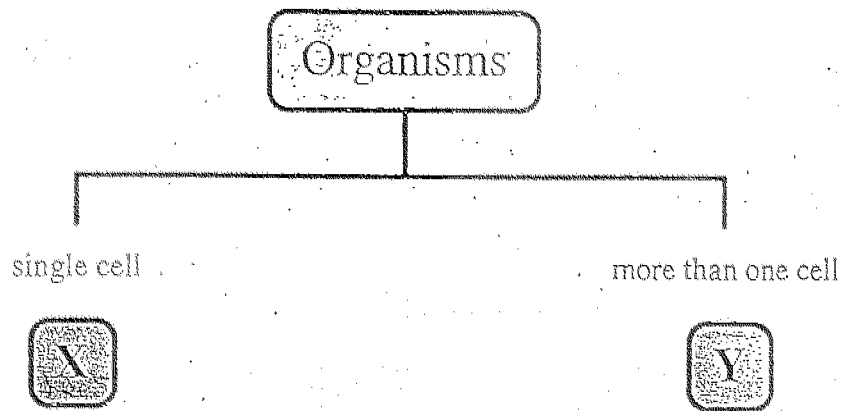

Which one of the following can *X* and *Y* be?

|     | X      | Y          |
|-----|--------|------------|
| (1) | Amoeba | Paramecium |
| (2) | Bee    | Cow        |
| (3) | Yeast  | Ant        |
| (4) | Rat    | Amoeba     |

12. Arrange the statements in sequence to show how global warming occurs and its effect.

|   |  |
|---|--|
| A | Carbon dioxide and harmful gases are released into the atmosphere.   |
| B | Temperature on Earth increases.                                      |
| C | Fossil fuels are burnt.  |
| D | These gases trap Sun's heat and prevent it from escaping into space. |
| E | Ice at the poles melts.  |

- (1) A, D, C, B, E  
 (2) B, D, C, A, E  
 (3) C, A, D, B, E  
 (4) B, E, A, C, D

13. Which set of pie charts shows correctly the percentage of gases present in the air we breathe in and the air we breathe out?

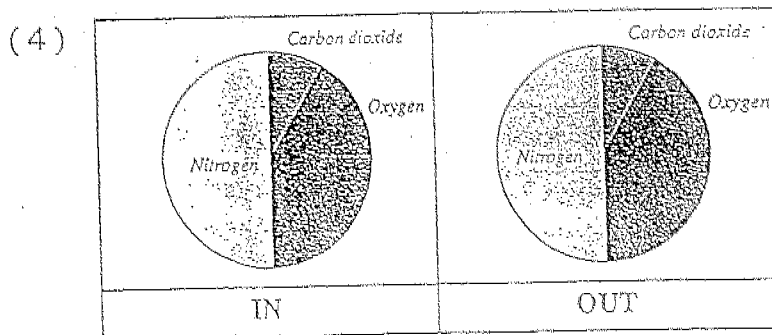
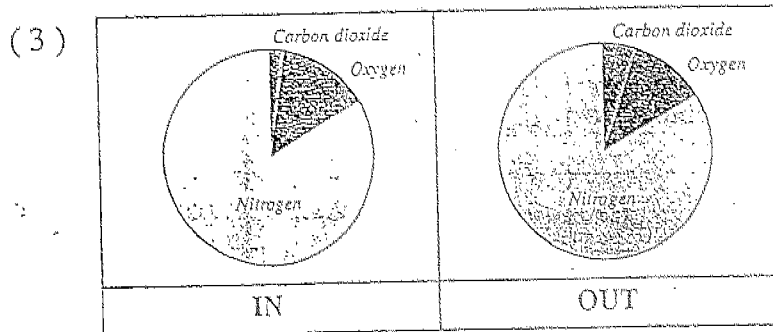
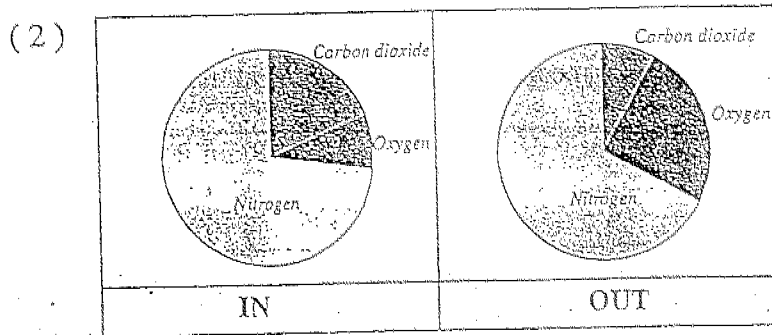
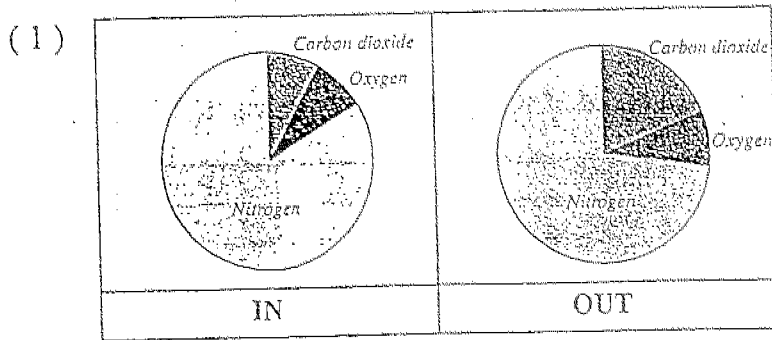

For questions 14 and 15 use the information below.

Jessica wanted to examine the effect of fertiliser on four balsam plants, P, Q, R and S over a period of time. At the start of the experiment, each plant was about 10 cm tall and had 6 dark green leaves of about equal size.

The table below shows the amount of water and fertilizer given to each plant.

|                              | Plant P              | Plant Q | Plant R       | Plant S |
|------------------------------|----------------------|---------|---------------|---------|
| Amount of water per day (ml) | 60                   | 60      | 60            | 20      |
| Amount of fertilizer (drops) | 6 drops every 5 days | 0       | 6 drops daily | 0       |

At the end of the experiment, she recorded her observations in the table below.

|                       | Plant P    | Plant Q    | Plant R    | Plant S         |
|-----------------------|------------|------------|------------|-----------------|
| Height of plants (cm) | 20         | 12         | 13         | 10              |
| Number of leaves      | 15         | 8          | 10         | 2               |
| Colour of leaves      | dark green | dark green | dark green | yellowish green |

14. What effect did the daily use of fertiliser have on the plants?

|     | Height of plant | Number of leaves |
|-----|-----------------|------------------|
| (1) | Doubled         | decreased        |
| (2) | Doubled         | increased        |
| (3) | Increased       | increased        |
| (4) | Increased       | stayed the same  |

15. Which plant is the "control" for this experiment?

- (1) Plant P
- (2) Plant Q
- (3) Plant R
- (4) Plant S

16. The graphs below show the temperature of water in 4 containers, A, B, C and D. Which container of water undergoes changes in all three states?

(1)

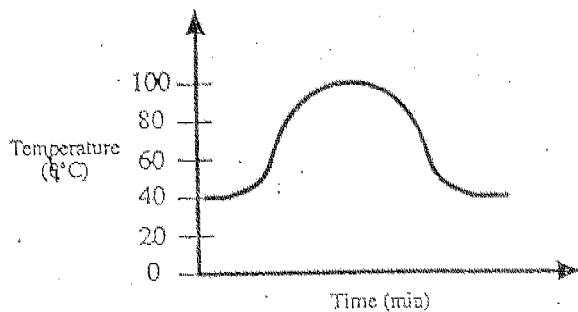

Container A

(2)

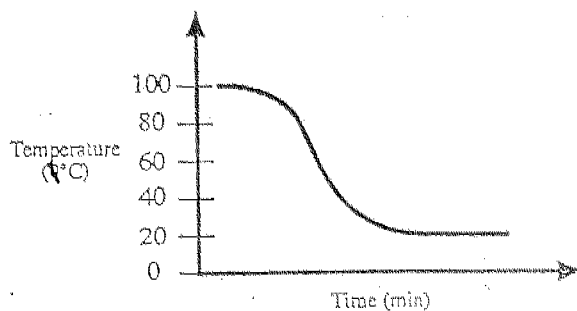

Container B

(3)

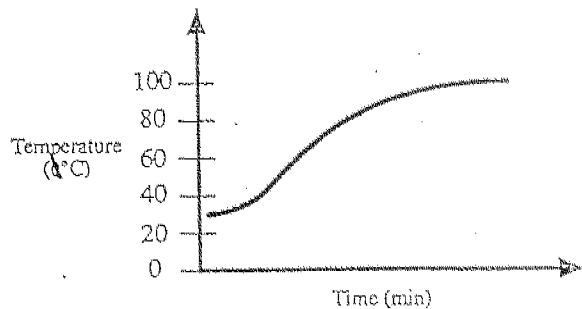

Container C

(4)

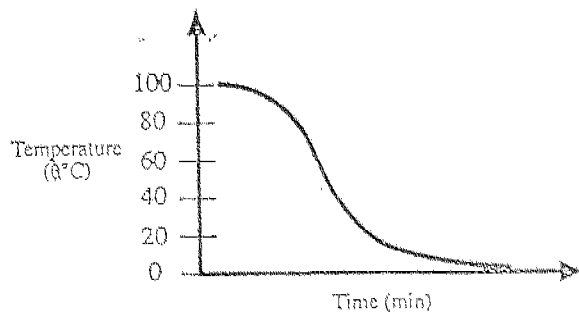

Container D

17. The chart below shows that animals can be classified according to their outer body coverings.

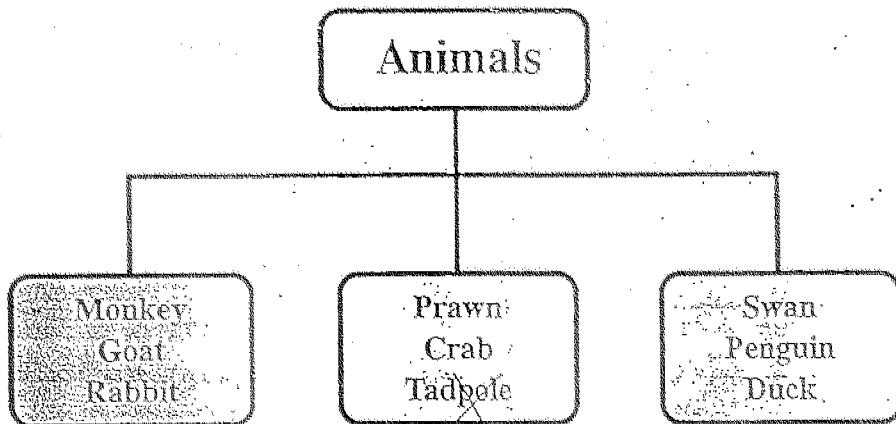

Which one of the animals is wrongly classified in the chart shown above?

- (1) penguin
  - (2) duck
  - (3) rabbit
  - (4) tadpole
18. The diagram below shows the pod of a plant.

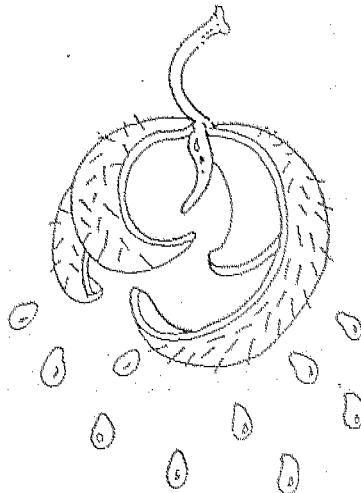

We can conclude that the plant \_\_\_\_\_.

- (1) has edible parts
- (2) is a flowering plant
- (3) has seeds dispersed by animals
- (4) has small and indigestible seeds

19. Look at the food web below.

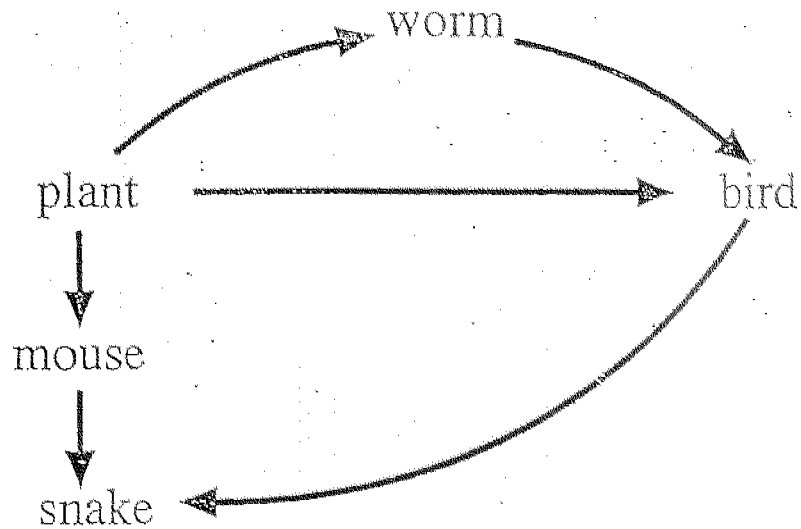

Which one of the following graphs shows the immediate change in the population of snake when the population of plant increases?

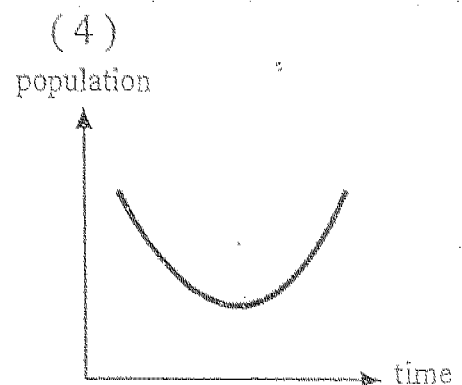
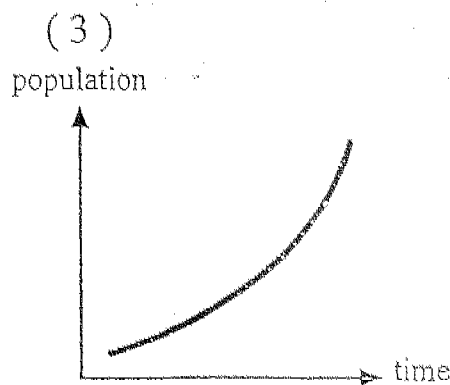
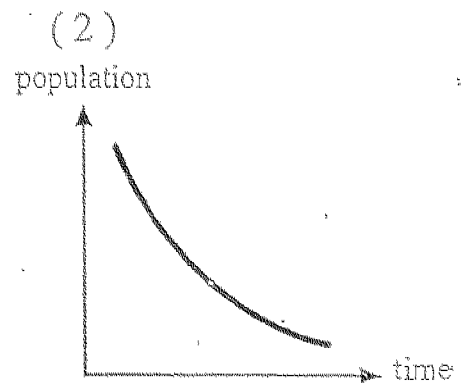
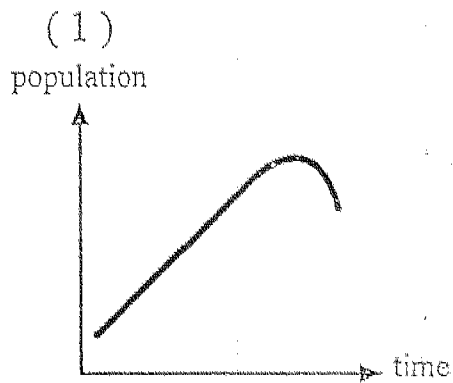



20. The diagram below shows how 4 magnets are joined together.

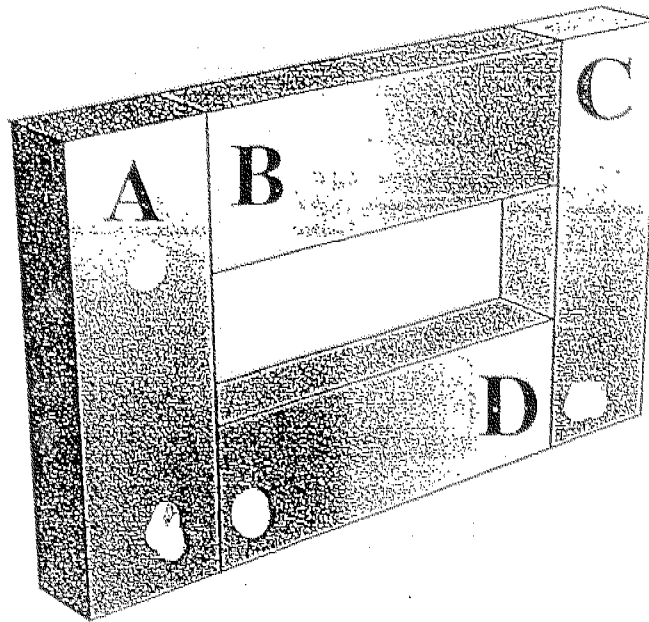

Which one of the following shows correctly which poles A, B, C and D represent?

|     | A     | B     | C     | D     |
|-----|-------|-------|-------|-------|
| (1) | South | South | North | North |
| (2) | North | North | South | South |
| (3) | South | North | South | North |
| (4) | North | South | South | South |

21. Which one of the following statements about fossil fuels is **not** true?

- (1) They contain chemical energy
- (2) They are found in the ground.
- (3) Burning of fossil fuels causes air pollution..
- (4) The usage of fossil fuels causes the depletion of ozone layer.

22. Study the diagram below.

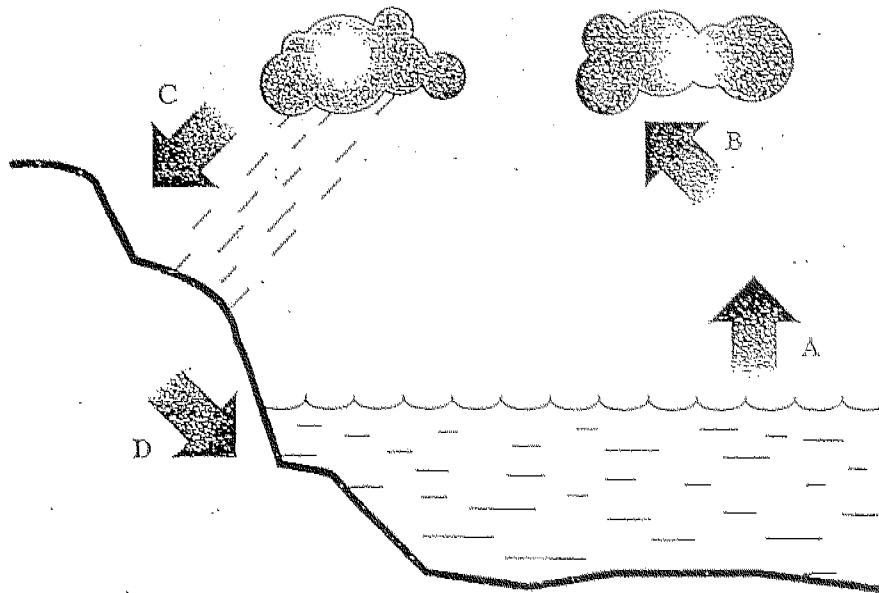

The increase in the temperature of the air will directly affect one of the above processes, A, B, C or D and cause it to increase in rate. The process is \_\_\_\_\_.

- (1) A
- (2) B
- (3) C
- (4) D

23. Which one of the following adaptations enables the camel to live in the desert?

- (1) The hump stores water.
- (2) The long lashes protect the eyes from the sand.
- (3) The bristles under the feet prevent it from sinking into the sand.
- (4) The thin skin on the knees allows heat to escape rapidly.

24. The table below shows the length of the shadow of a stick at different times of the day.

|                       |      |       |       |      |      |
|-----------------------|------|-------|-------|------|------|
| Time                  | 8 am | 10 am | 12 pm | 2 pm | 4 pm |
| Length of shadow (cm) | 80   | 40    | 0     | 40   | 80   |

Which one of the following graphs corresponds to the table?

(1)

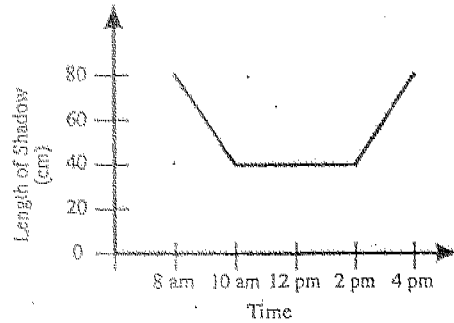

(2)

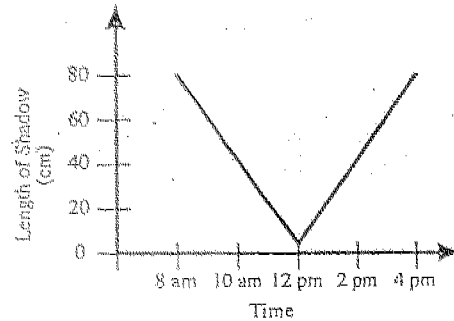

(3)

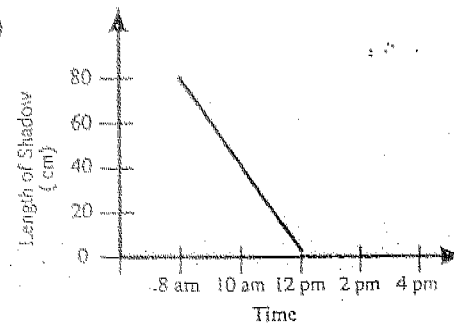

(4)

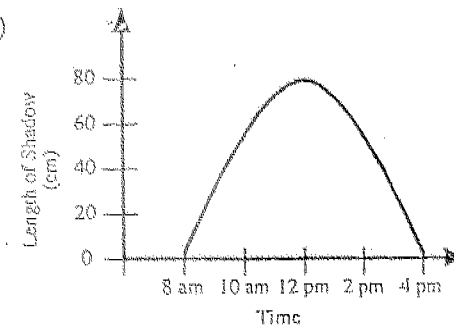

25. The diagram below shows objects in the Solar System.

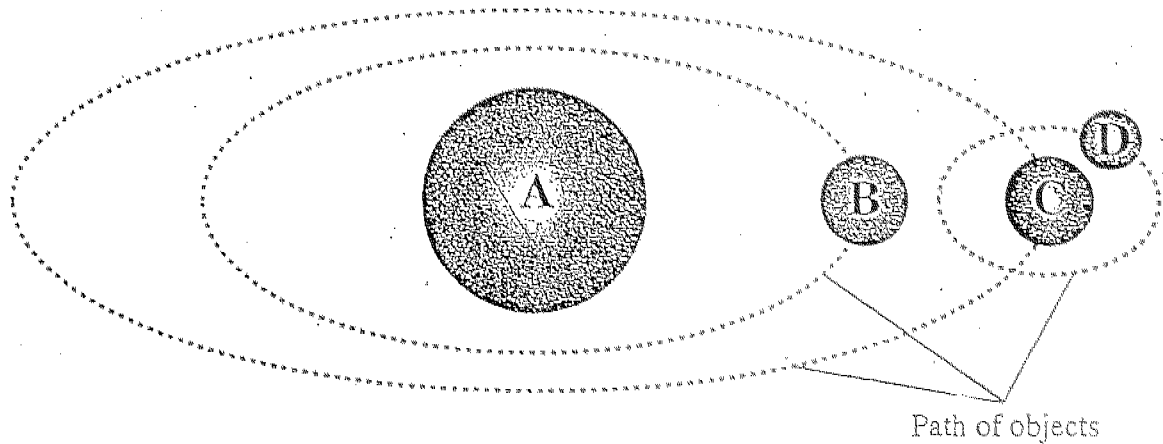

Descriptions about each object are given below.

- Object A is a source of light.
- Object B moves around object A.
- Object C moves around object A.
- Object D moves around object C.

What could the object be?

|     | A    | B       | C       | D       |
|-----|------|---------|---------|---------|
| (1) | Sun  | Mercury | Earth   | Moon    |
| (2) | Sun  | Earth   | Moon    | Mercury |
| (3) | Moon | Earth   | Mercury | Sun     |
| (4) | Moon | Mercury | Earth   | Sun     |

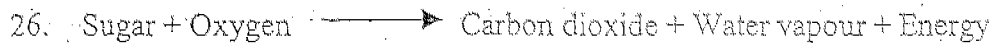

The above shows a process that happens in living things. What process does it represent?

- (1) Respiration
- (2) Photosynthesis
- (3) Fermentation
- (4) Decomposition

27. Four circuits using similar batteries and bulbs are shown below.

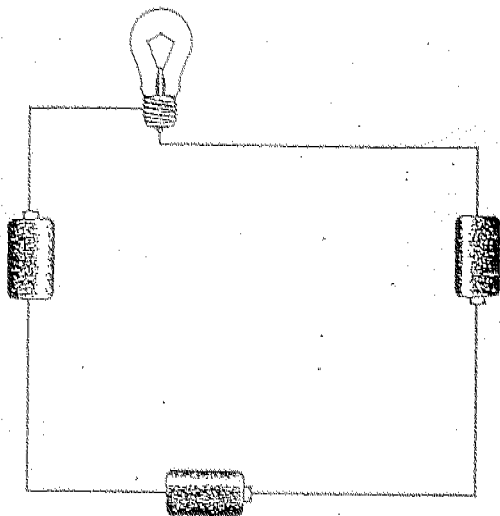

Circuit A

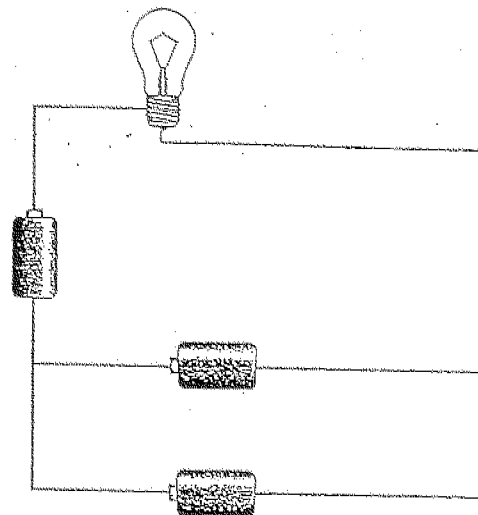

Circuit B

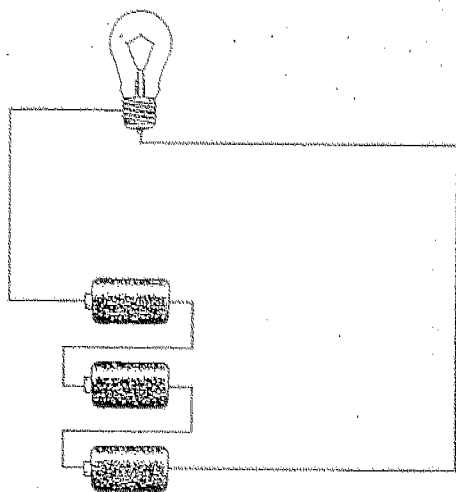

Circuit C

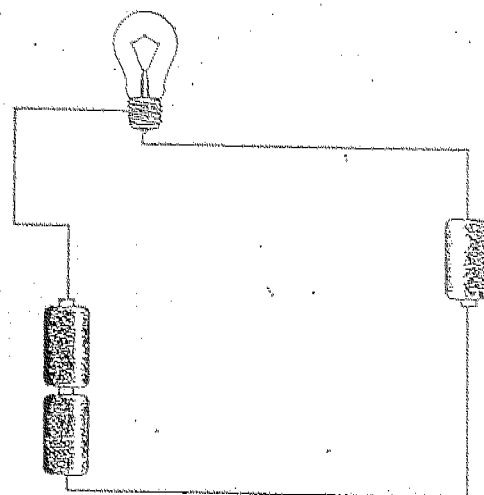

Circuit D

In which two circuits are the bulbs of equal brightness?

- (1) A and B
- (2) B and C
- (3) A and C
- (4) C and D

28.

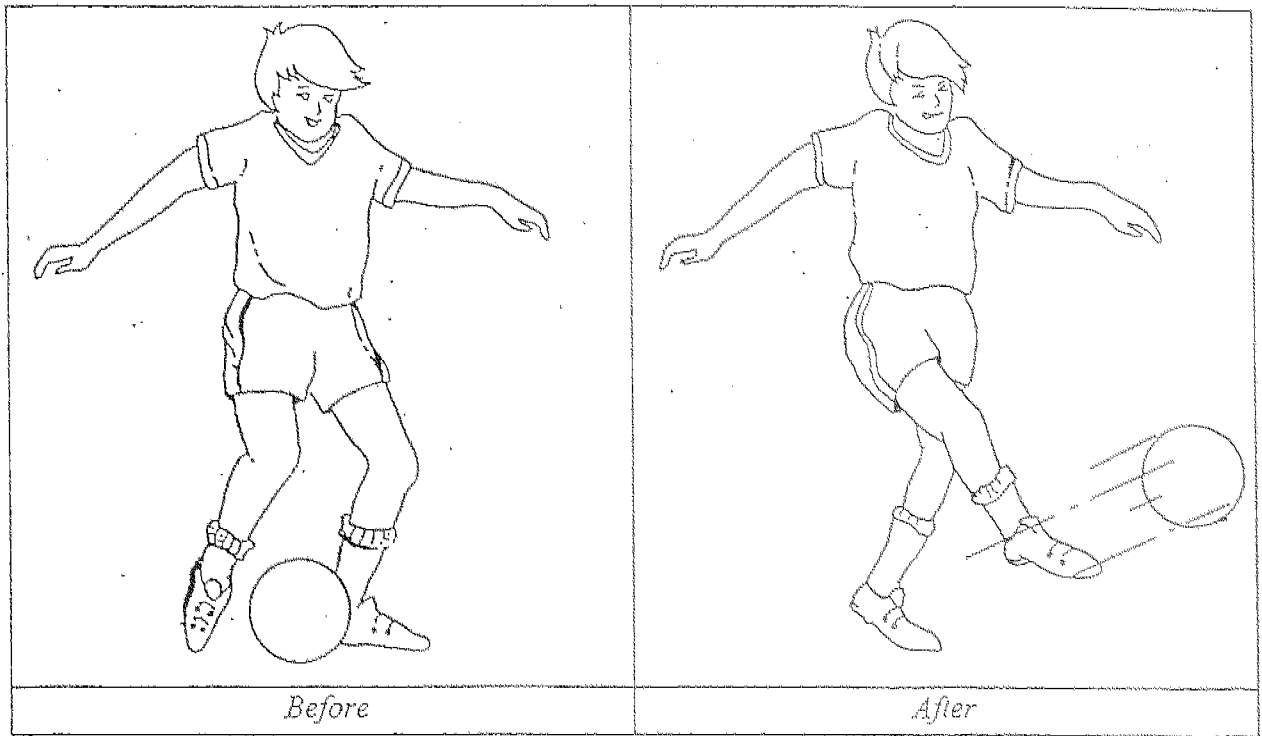

The pictures above show that a force can \_\_\_\_\_.

- (1) change the shape of an object.
  - (2) change the direction of a moving object.
  - (3) move a stationary object.
  - (4) slow down a moving object.
29. Which one of the following actions will slow down the depletion of natural resources?
- (1) Increasing the world population.
  - (2) Protecting our rainforests.
  - (3) Building more factories.
  - (4) Increasing the number of cars.

30. Study the flow chart carefully.

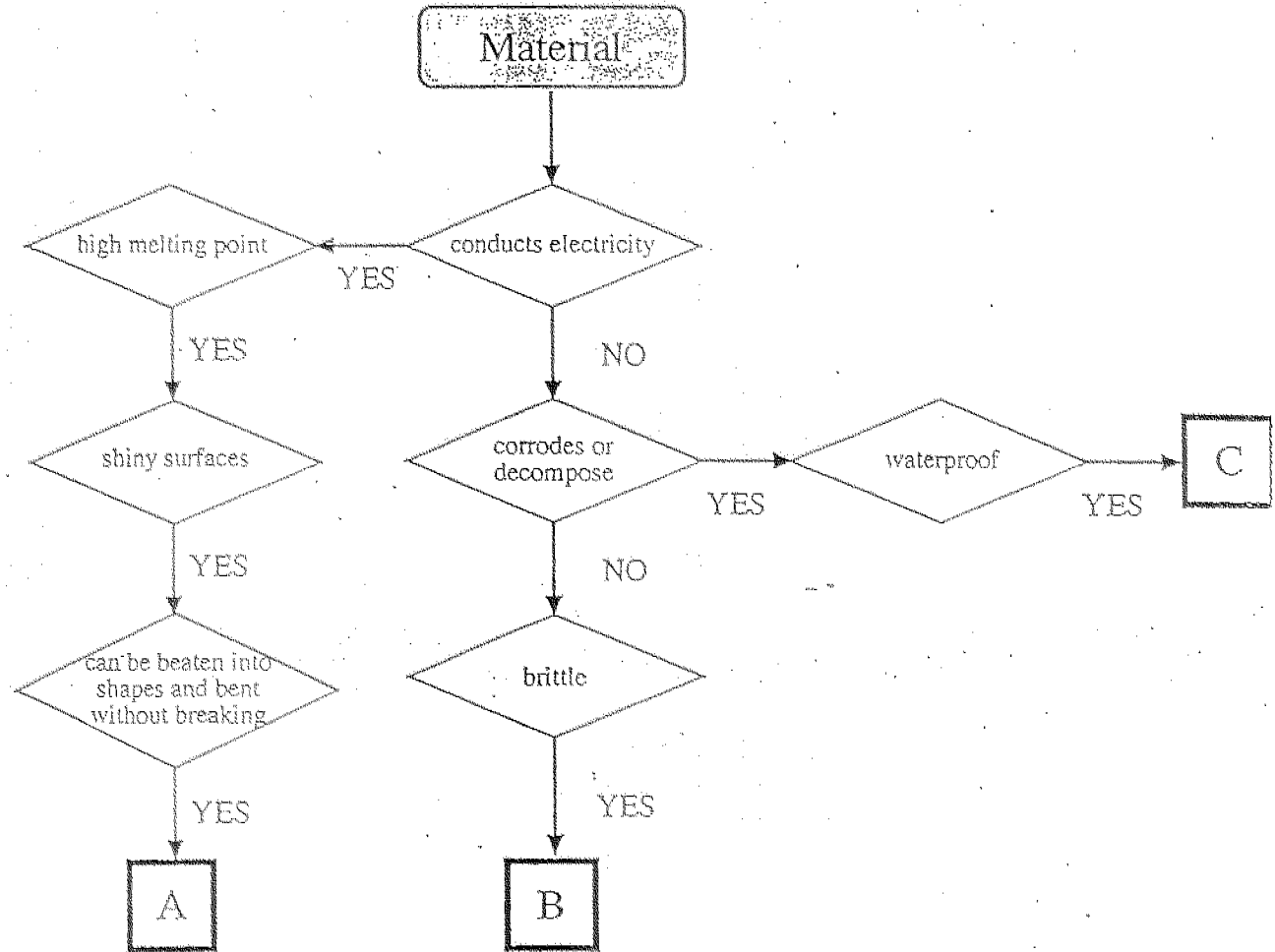

What does letter A, B and C represent?

|     | A        | B        | C        |
|-----|----------|----------|----------|
| (1) | gold     | ceramics | rubber   |
| (2) | glass    | wood     | plastic  |
| (3) | silver   | rubber   | ceramics |
| (4) | ceramics | plastic  | wood     |

Section B: Write your answers to questions 31 to 46 in the spaces provided.

31. Mike set up an experiment using a hydrilla plant as shown in the diagram below.

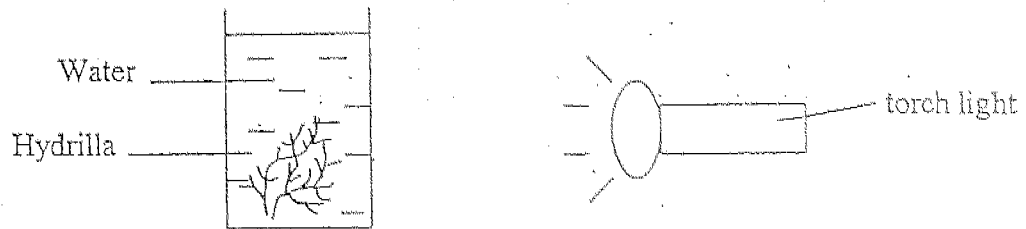

He measured the distance of the torch light from the beaker and the number of bubbles given out per minute by the hydrilla. He repeated the experiment 3 times by moving the torch light further from the beaker 5 cm each time.

He then plotted the graph shown below with the results he obtained.

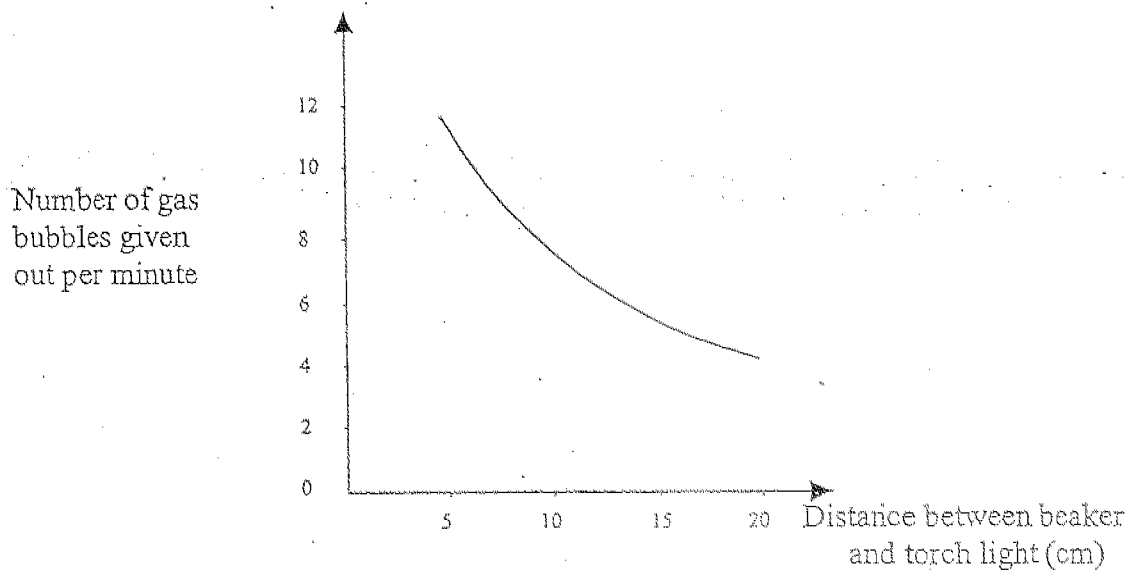

(a) Based on the above graph, what pattern do you see between the number of gas bubbles given out per minute and the distance of the beaker from the torchlight? [1]

---

---

(b) What is the process that is taking place in the plant that could produce the bubbles of gas? [1]

---

---



32. Sanjay took two identical empty bottles and a glass tubing and connected them as shown in the diagram below. In the glass tubing he had added a drop of red ink. He then placed each of the empty bottles in a basin of water.

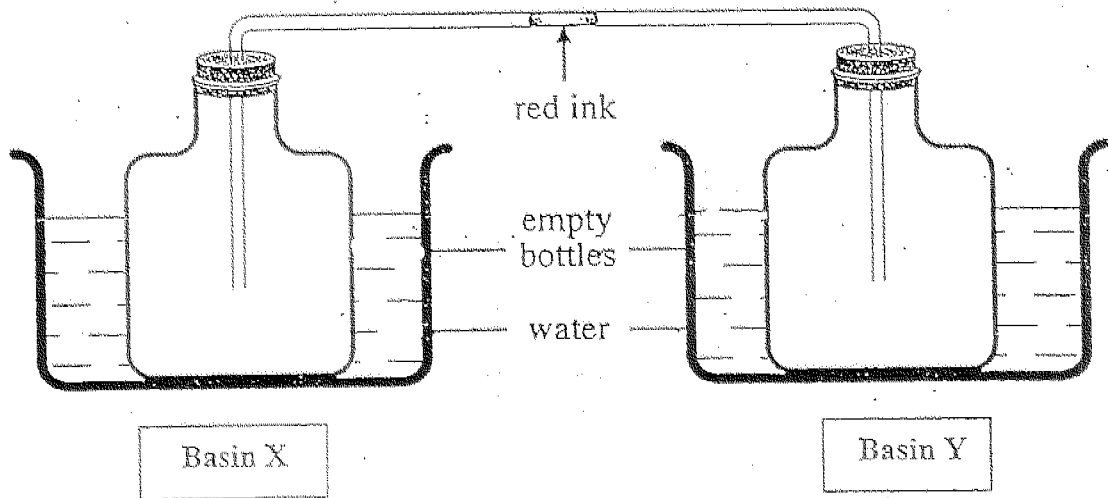

- (a) In the table below, state the direction of the movement of the red ink by writing "Towards X" or "Towards Y" when the water has the following set of temperatures. [1]

|      | Temperature of water ( $^{\circ}\text{C}$ ) |         | Direction of movement of the drop of red ink |
|------|---|---------|--|
|      | Basin X                                     | Basin Y |  |
| (i)  | 10  | 90      |  |
| (ii) | 55  | 0       |  |

- (b) Explain why the drop of red ink moves in (i). [1]

---



---



---

33.

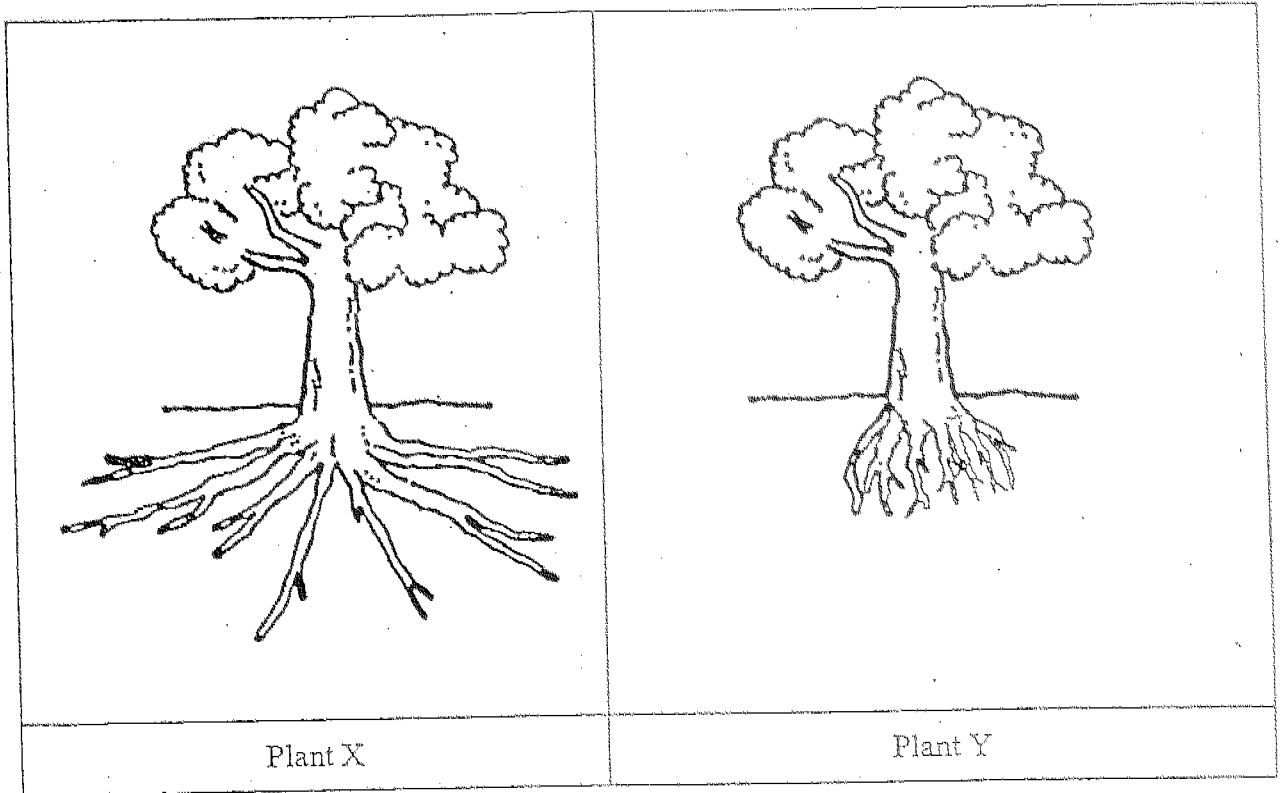

(a) Which plant, X or Y, is most likely to be uprooted during a storm? [1]

\_\_\_\_\_

(b) Give a reason for your answer in part (a). [1]

\_\_\_\_\_

\_\_\_\_\_

\_\_\_\_\_

34. James grew some bean plants in two similar pots as shown in the diagrams below. He placed both pots at the same place in the garden and gave them the same amount of water daily.

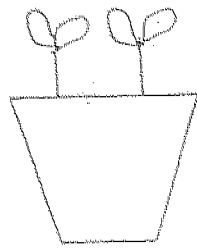

Pot A

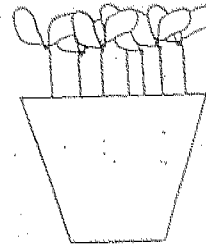

Pot B

James recorded the average height of the plants in Pot A and Pot B once every two days. After two weeks, he plotted the graph shown below based on the results that he obtained.

Lines P and Q represent the average height of the plants in each pot.

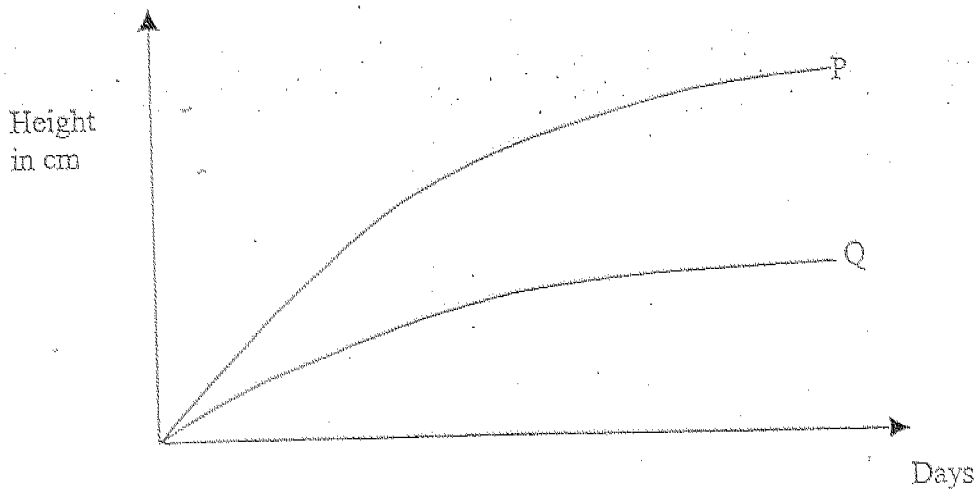

- (a) Which line, P or Q, represents the height of the plants in Pot B? [1]

---

- (b) Explain why you think so. [2]

---

---

---

35. Amy placed an opaque object in the middle of a glass table. She then shone a torch light from different positions X, Y and Z towards three walls, Wall A, Wall B and Wall C as shown in the diagram below.

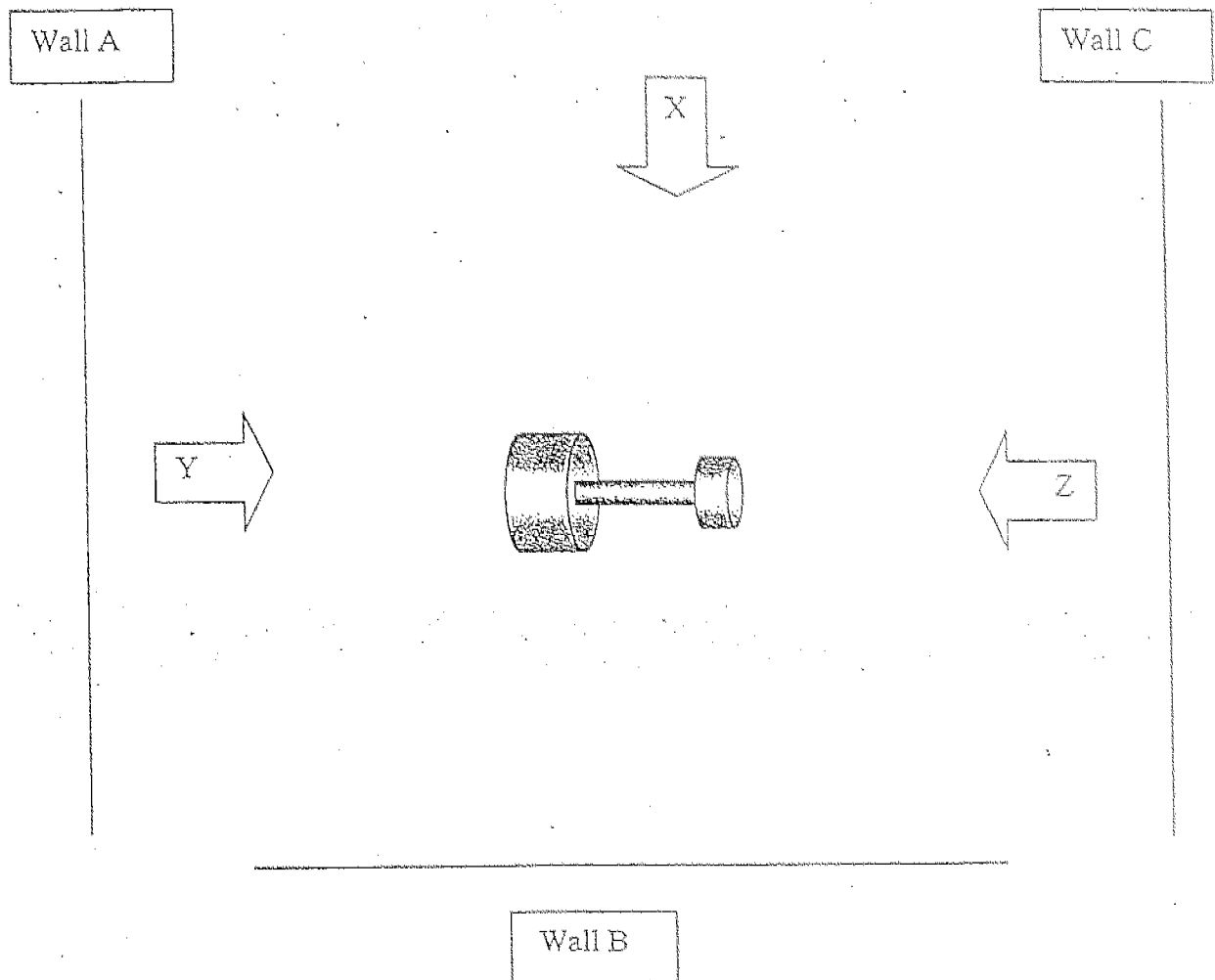

Draw the shadows cast on Walls A, B and C in the boxes provided below. [3]

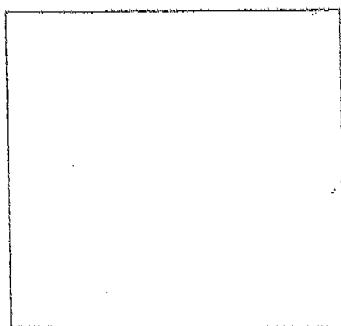

Wall A

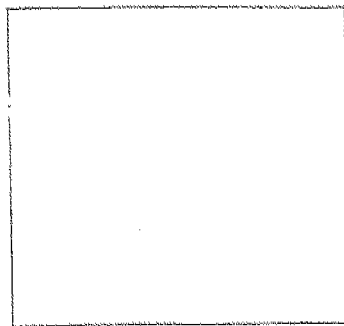

Wall B

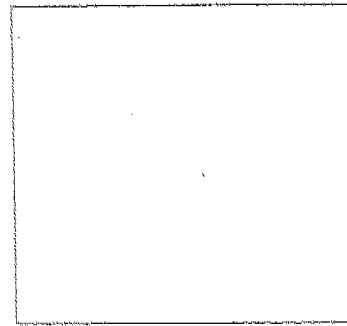

Wall C

36. The flow chart below shows the characteristics of some plants and the way they reproduce themselves. Study the chart carefully.

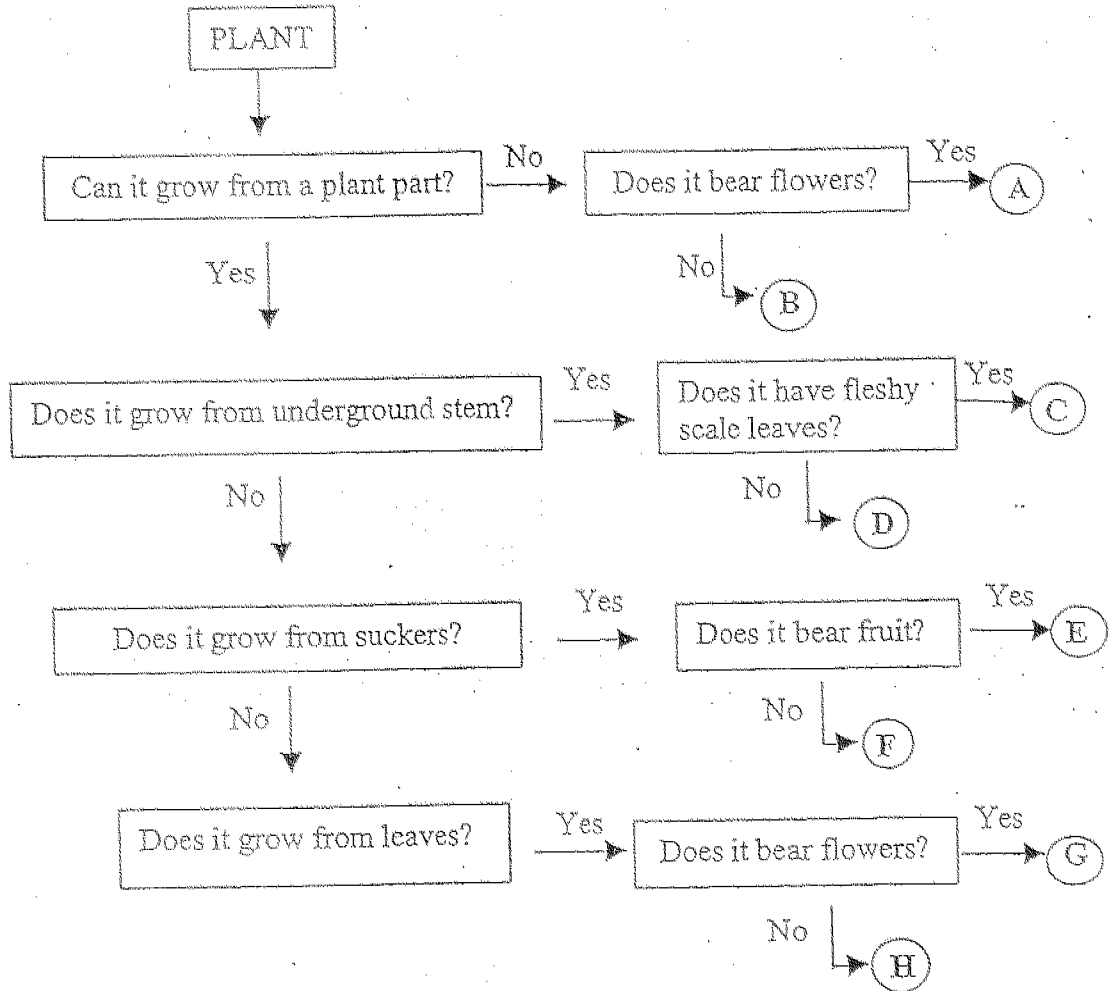

Use the information given in the chart and identify the plants listed below. [2]

| Plant          | Letter |
|----------------|--------|
| African violet |        |
| Banana         |        |
| Onion          |        |
| Pineapple      |        |

38. The diagram below shows a food web in a community.

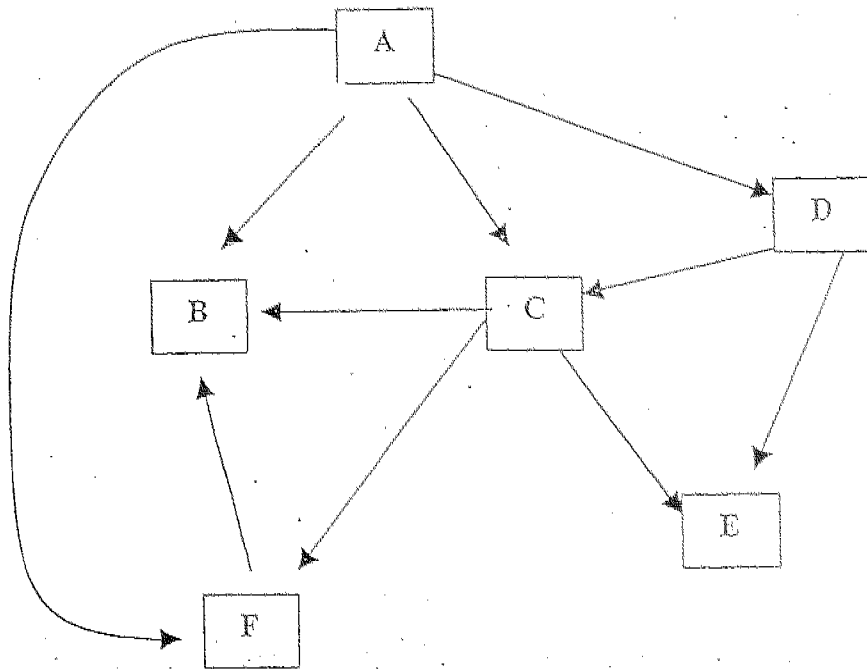

(a) If B is a carnivore, which arrow is wrongly placed?  
Circle the wrong arrow. [1]

(b) Name two omnivores in the food web. ~~///~~

(i) \_\_\_\_\_ [½]

(ii) \_\_\_\_\_ [½]

39. Electrical energy is widely used because it can be converted to other forms of energy. Study the mind-map carefully and fill in the rest of the boxes with the useful form of energy produced by each electrical appliance. [2]

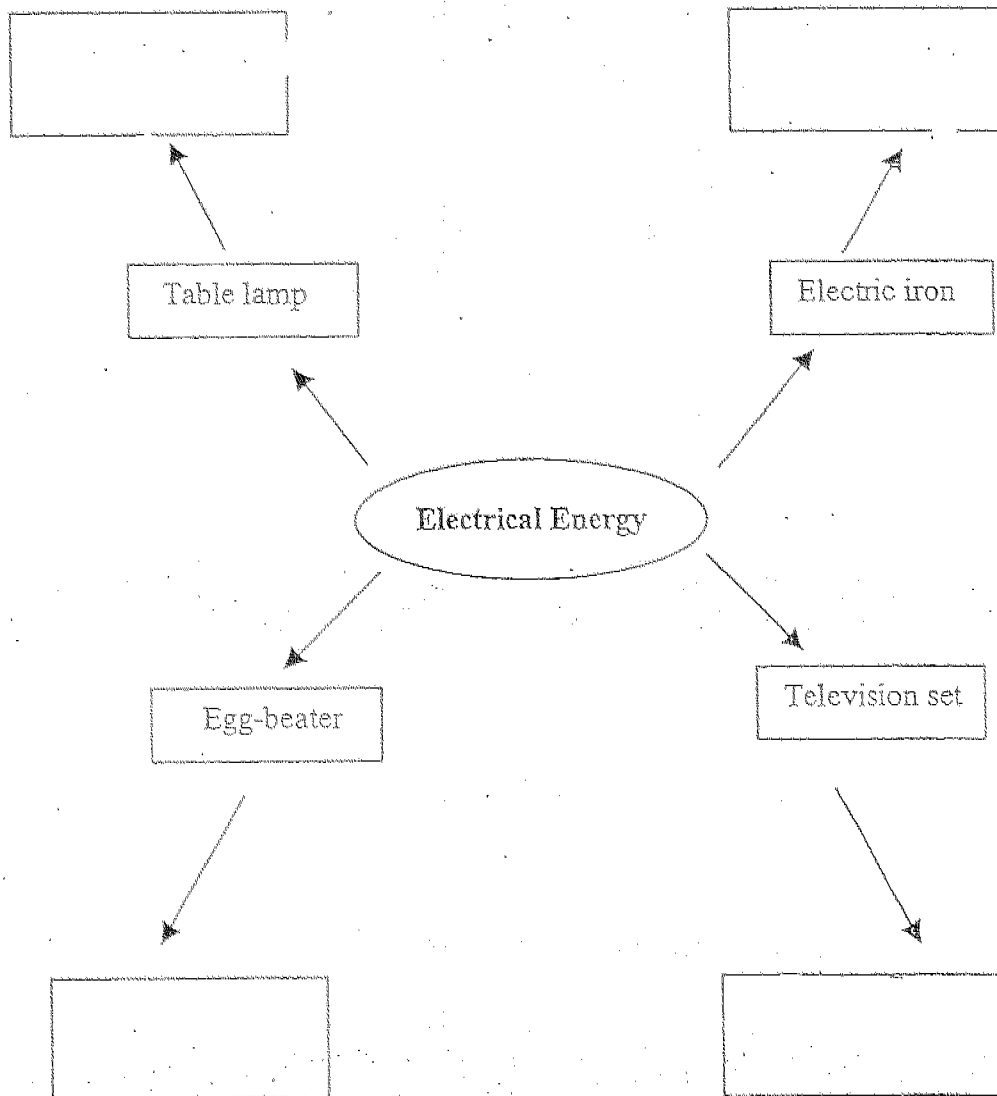

40. Eric carried out different activities for the same duration. These activities are represented by the letters A, B, C and D. He then measured his breathing rate and pulse rate for each activity. The results are recorded in the table shown below.

| Activity | Pulse rate/min | Breathing rate/min |
|----------|----------------|--------------------|
| A        | 65             | 30                 |
| B        | 70             | 35                 |
| C        | 105            | 50                 |
| D        | 130            | 65                 |

- (a) Complete the table below by writing the letters A, B, C and D to match the description of the activities that Eric had carried out. [2]

| Description of activities |  |
|---------------------------|--|
| Strolling                 |  |
| Jogging                   |  |
| Watching television       |  |
| Running                   |  |

- (b) What is the relationship between his pulse rate and his breathing rate? [1]

---



---



---



41. An experiment was carried out to determine the effect of leftover food on the growth of plants. Some leftover food was buried in Plot X, but not in Plot Y. The quality of soil in Plot X and Plot Y were similar and the two plots of land were given equal attention. The plant growth in each plot was observed over a period of 4 months and recorded in the table below.

| Plots of land | Presence of leftover food | Growth development of plants                    |
|---------------|---------------------------|---|
| Plot X        | Yes                       | More green and healthy leaves on plants.        |
| Plot Y        | No                        | Fewer green and healthy leaves found on plants. |

(a) Explain the difference in the growth development of plants in the two plots of land. [1]

---

---

(b) Does burying the leftover food pollute the environment? Explain your answer. [2]

---

---

---

42. The classification chart below shows how some aquatic animals are classified.

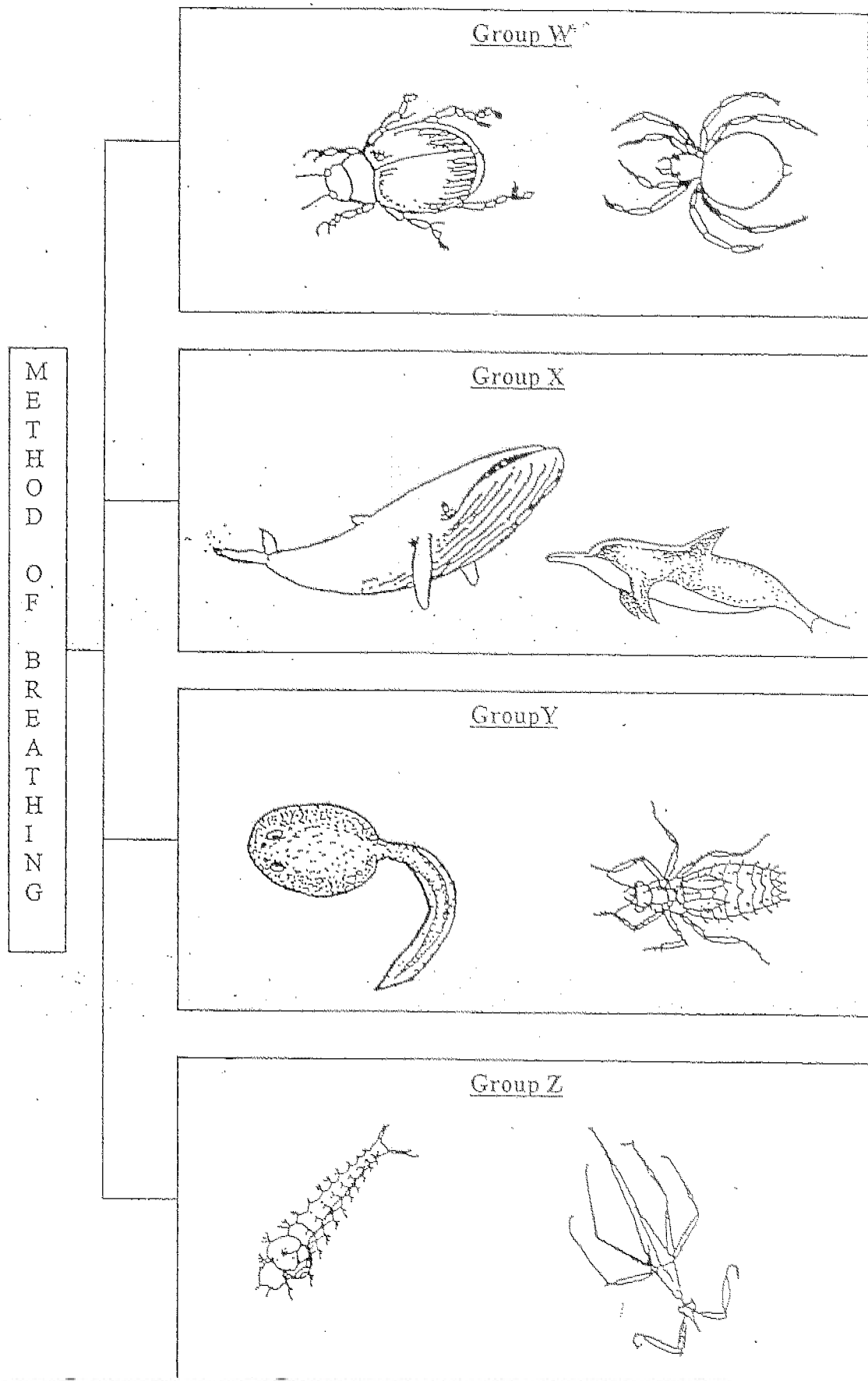

(a) Give suitable headings for groups Y and Z. [1]

Group Y : \_\_\_\_\_

Group Z : \_\_\_\_\_

(b) In which group W, X, Y or Z should the animal shown below be classified? [1]

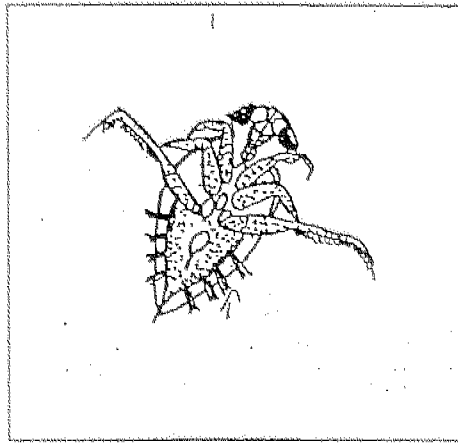

Group \_\_\_\_\_

(c) The tubifex worm cannot be placed in any of the given groups.  
Explain why this is so. [1]

\_\_\_\_\_  
\_\_\_\_\_

43. An iron nail is suspended freely midway between Electromagnet A and Electromagnet B.

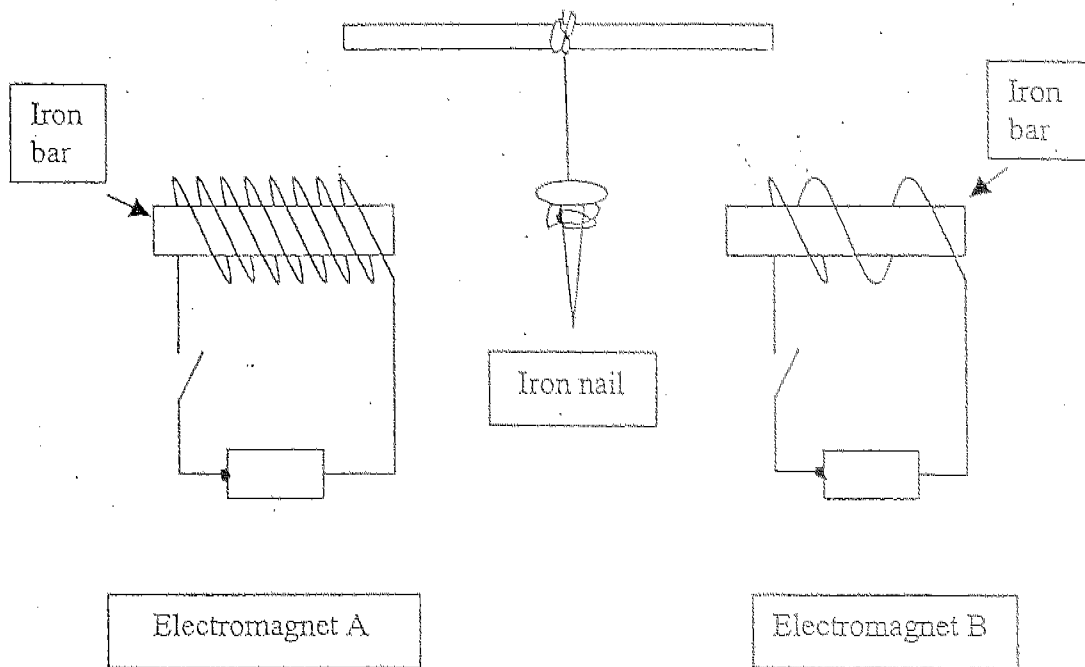

- (a) If both circuits are closed, what will happen to the iron nail? [1]

---

---

- (b) Explain your answer. [2]

---

---

44. The chart below represents reproduction in human beings. Complete the chart by writing the correct answer in each box. [2]

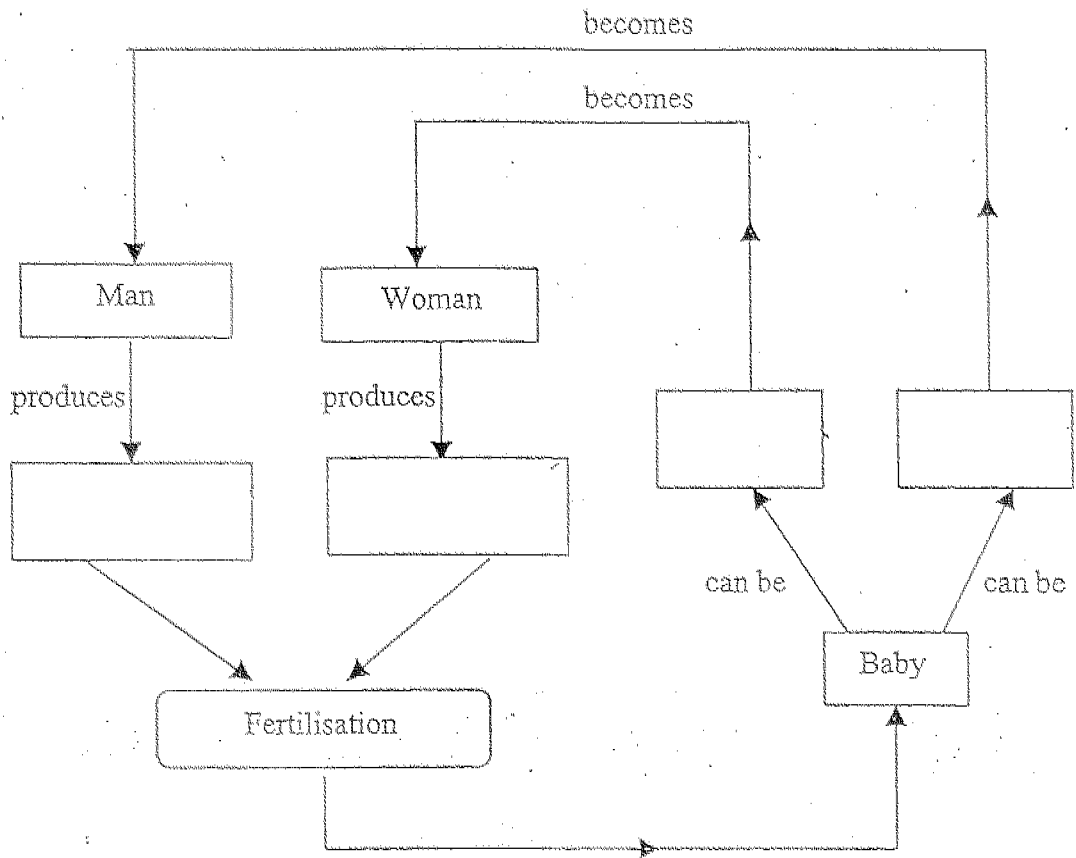

45. Ravi took two identical empty tins and made a hole in each as shown in the diagram. He then plugged the holes with some plasticine and filled both tins with the same amount of water. He put the tins on a balance beam as shown in the diagram below. Then Ravi removed the plasticine plugs on both tins at the same time to allow water to flow out from the holes.

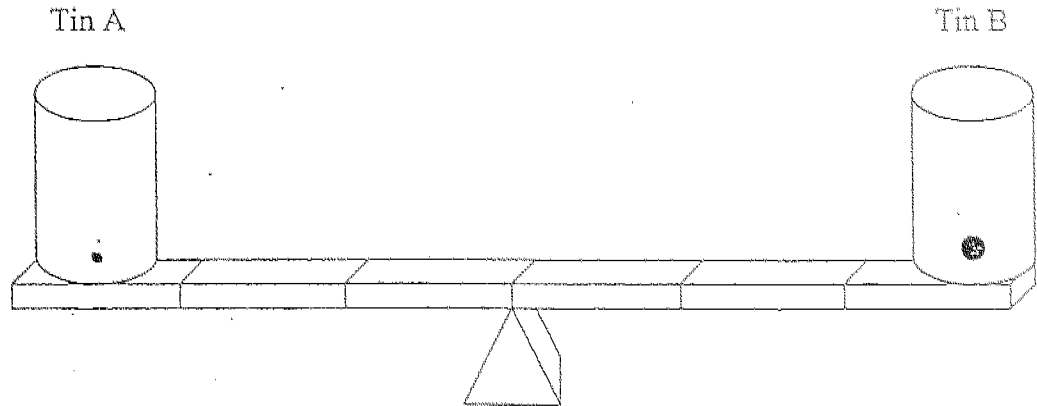

- (a) If the beam is balanced at the beginning of the experiment, state what will happen to it after a short while. [1]

---

---

- (b) Explain your answer in part (a). [2]

---

---

---

46.

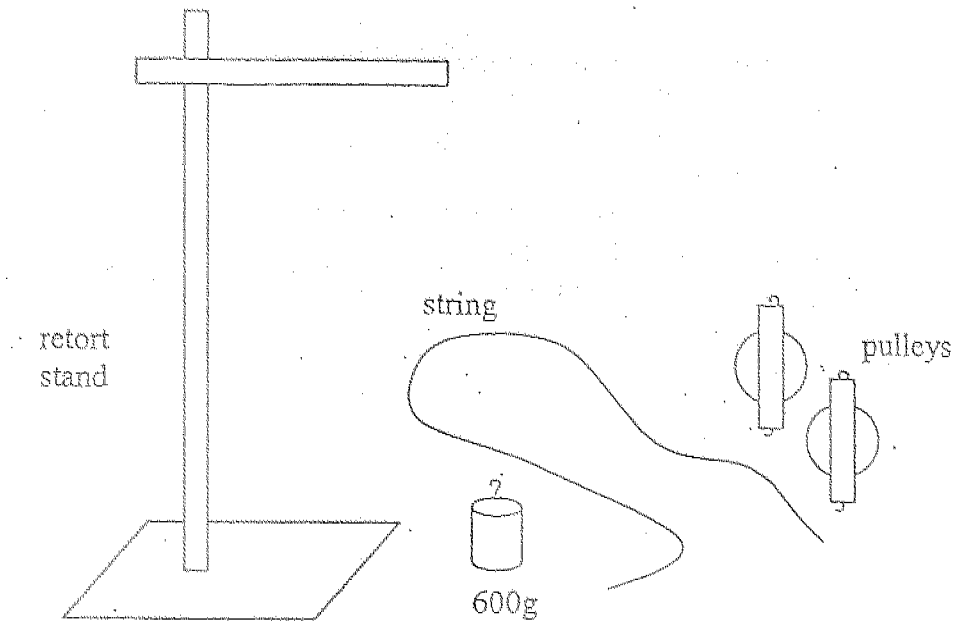

You are given a retort stand, two pulleys, a length of string and a load of 600 grams as shown above.

Show by drawing in the box below, how best you can set up the apparatus so that the force needed to lift the load is about half the load. [2]

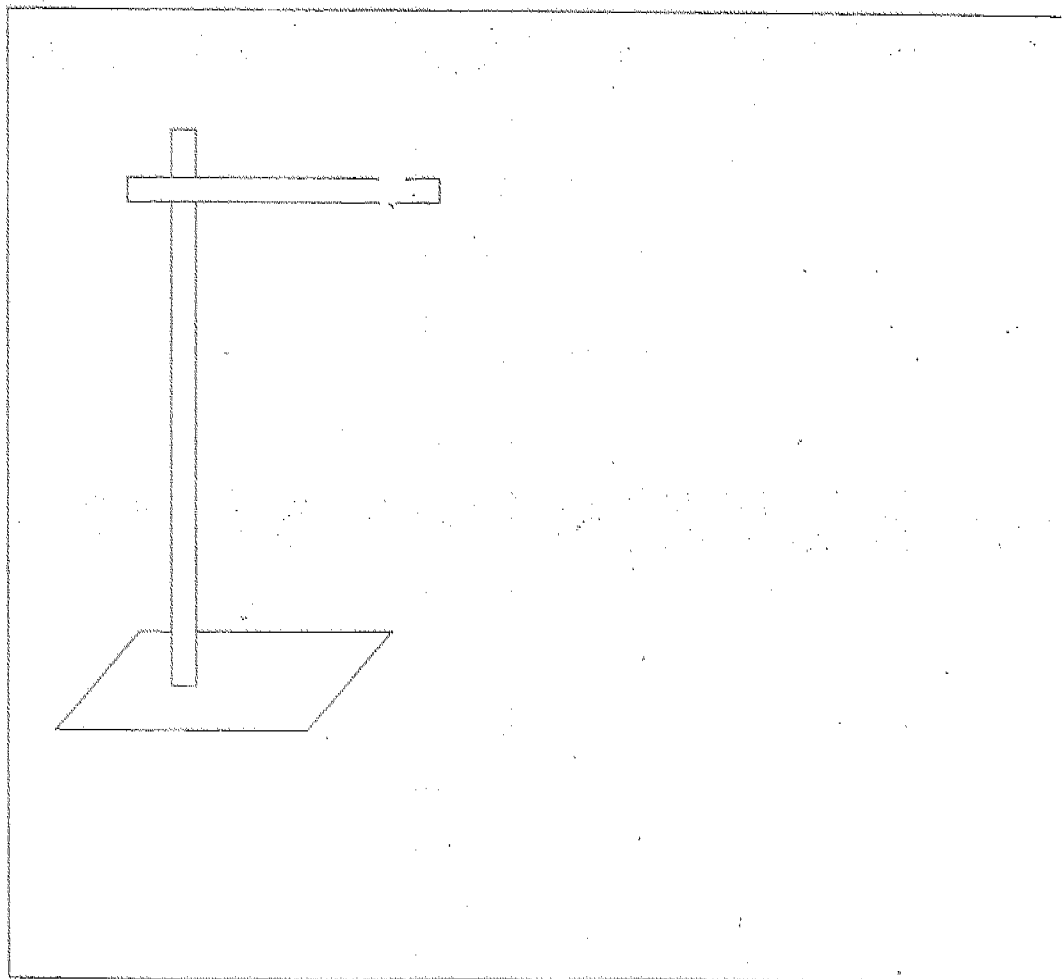

HOKIEN HUAY KUAN 5-SCHOOL PRIMARY 6  
 COMBINED PRELIMINARY EXAMINATION (1)  
 SCIENCE

|         |         |         |
|---------|---------|---------|
| 01. 2   | 11. 3   | 21. 4   |
| 02. 4   | 12. 3   | 22. 1   |
| 03. 4   | 13. (3) | 23. (2) |
| 04. (3) | 14. 3   | 24. 2   |
| 05. 2   | 15. 2   | 25. 1   |
| 06. 4   | 16. 4   | 26. 1   |
| 07. 2   | 17. 4   | 27. 4   |
| 08. 4   | 18. (2) | 28. 3   |
| 09. 2   | 19. 3   | 29. 2   |
| 10. 2   | 20. 4   | 30. 1   |

31) a) The greater the distance of the beaker from the torch light, the lesser the number of gas bubbles given out per minute.

b) Photosynthesis.

32) a) (i) Towards X  
 (ii) Towards Y

b) The air in the empty bottle expands when it is placed in hotter water in Basin Y and pushes the drop of red ink towards the other empty bottle which is placed in the colder water.

33) a) Plant Y

b) The roots in Plant Y are not spread out widely and so are not able to hold the tree firmly to the ground.

34) a) Line P

b) Plants in Pot B are overcrowded so they need to grow taller to get more sunlight.

35)

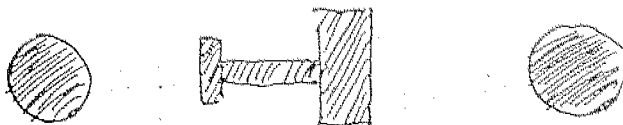

36) A

E

C

E

37) a) It was to see how the temperature of the water affected the time taken for the cube of sugar to dissolve.

b) i) Volume of the sugar cube.

ii) Amount of water



39) Light  
Energy

Heat  
Energy

Kinetic  
Energy

Light Energy  
Sound Energy

40) a) B  
C  
A  
D  
The greater his pulse rate, the greater his breathing rate.

41) a) When the leftover food decomposed, it released nutrients for the plants in Plot X, so they grew better.  
b) Yes, if the food is not buried properly, it will attract pests and give off an unpleasant smell.

42) a) Breathe through gills  
Breathe through breathing tubes.

b) W

c) It breathes through its skin.

43) a) The iron nail will be attracted to Electromagnet A.  
b) Electromagnet A has more coils of wire around it than Electromagnet B, thus A has more magnetic force than B.

44) sperms      egg      girl      boy

45) a) Tin A would be heavier than Tin B, so Tin A would be lower than Tin B.

b) Tin B has a bigger hole, so water flows out of at a faster rate. More water flows out of Tin B, it becomes lighter than Tin A.

46)

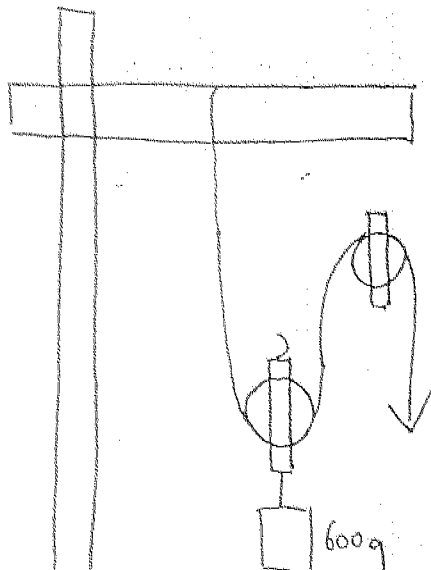

# 福建会馆属下五校小六统一考试 (二)

道南 • 爱同 • 崇福 • 南侨 • 光华

HOKKIEN HUAY KUAN 5-SCHOOL PRIMARY 6  
COMBINED PRELIMINARY EXAMINATION (II)

TAO NAN • AI TONG • CHONGFU • NAN CHIAU • KONG HWA



## NOTE:

1. Do not open this booklet until you are told to do so;
2. Follow carefully the instructions given at the beginning of each section of the booklet.
3. Do not waste time. If a question is difficult for you, go on to the next one.

Total time: 1h 45min

School : \_\_\_\_\_

Name : \_\_\_\_\_

Class : \_\_\_\_\_

PART 1 (60 marks)

For each question from 1 to 30, four options are given. One of them is the correct answer. Make your choice (1, 2, 3 or 4). Shade the correct oval (1, 2, 3 or 4) on the Optical Answer Sheet.

1. The diagram shows a cell from the outer covering of an onion. Which part allows some, but not all, substances to pass into and out of the cell?

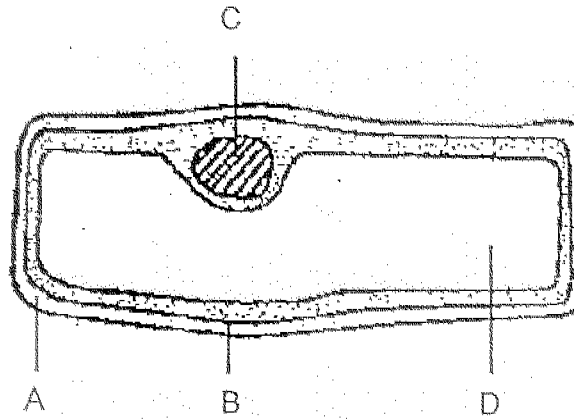

- (1) A
- (2) B
- (3) C
- (4) D

2. The diagrams show four different cells as seen through a microscope. Which cell has no nucleus?

(1)



(2)



(3)



(4)

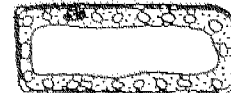

3. Which structures are present in an animal cell?

|     | cell membrane | cell wall | chloroplasts | cytoplasm |
|-----|---------------|-----------|--------------|-----------|
| (1) | X             | √         | √            | √         |
| (2) | √             | X         | X            | √         |
| (3) | √             | X         | √            | X         |
| (4) | √             | √         | X            | √         |

Key :        √ — structure present  
               X — structure absent

4. The diagram shows a section of a stem.

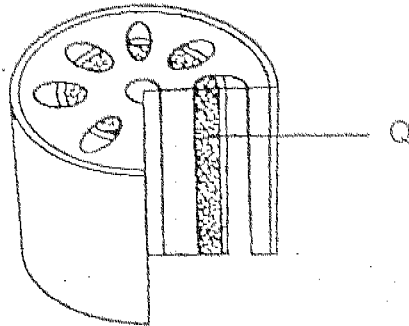

Which is the main transport function of tissue Q?

|     | Substance transported | Carried from | Carried to |
|-----|-----------------------|--------------|------------|
| (1) | sugar                 | roots        | leaves     |
| (2) | sugar                 | leaves       | roots      |
| (3) | water                 | roots        | leaves     |
| (4) | water                 | leaves       | roots      |

5. Which of the following represents the shortest path taken by the blood travelling from a leg to an arm in a human body?

- (1) leg → heart → lungs → heart → arm
- (2) leg → heart → lungs → arm → heart
- (3) leg → lungs → heart → arm → heart
- (4) leg → lungs → heart → lungs → arm

6. The diagram shows the structure of a flower.

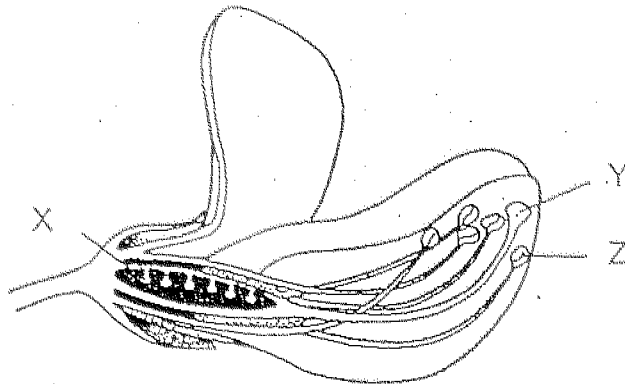

Where do pollination and fertilisation take place?

|     | Pollination | Fertilisation |
|-----|-------------|---------------|
| (1) | X           | Y             |
| (2) | Y           | X             |
| (3) | Y           | Z             |
| (4) | Z           | Y             |

7. Four pupils classified some plants according to how they reproduce vegetatively. Based on the table, which pupil classified all the plants correctly?

| Pupil | Leaf or leaf cutting                               | Sucker           | Underground stem                           | Storage root         |
|-------|--|------------------|--|----------------------|
| (1)   | <input checked="" type="checkbox"/> Begonia        | Pineapple        | <input checked="" type="checkbox"/> Carrot | Groundnut            |
| (2)   | <input checked="" type="checkbox"/> Bryophyllum    | Tapioca          | <input checked="" type="checkbox"/> Ginger | Turnip               |
| (3)   | <input checked="" type="checkbox"/> African tulip  | Ginger           | <input checked="" type="checkbox"/> Onion  | Radish <i>Radish</i> |
| (4)   | <input checked="" type="checkbox"/> African violet | Sealing wax palm | <input checked="" type="checkbox"/> Potato | Sweet potato         |

8. Study the diagram of the human skeleton carefully.

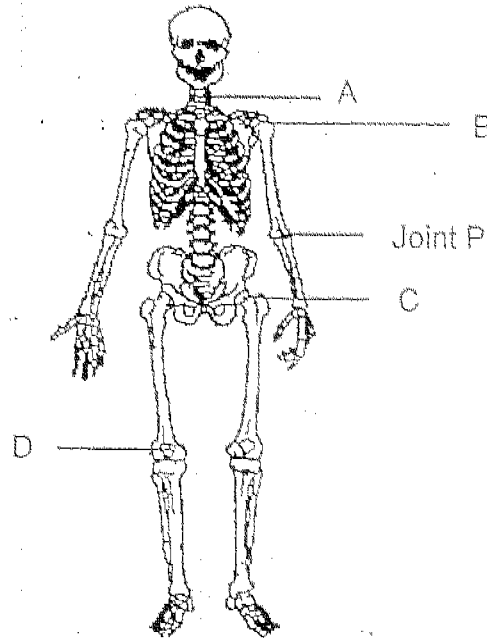

Which one of the following labelled joints moves in the same way as Joint P?

- |       |       |
|-------|-------|
| (1) A | (2) B |
| (3) C | (4) D |
9. Draining stagnant water is one method of controlling the population of mosquitoes. Which stages in the life cycle of a mosquito does this method control?
- |                        |
|------------------------|
| (1) egg, larva, adult  |
| (2) egg, larva, pupa   |
| (3) egg, pupa, adult   |
| (4) larva, pupa, adult |

10. Huiling sets up the experiment as shown below.

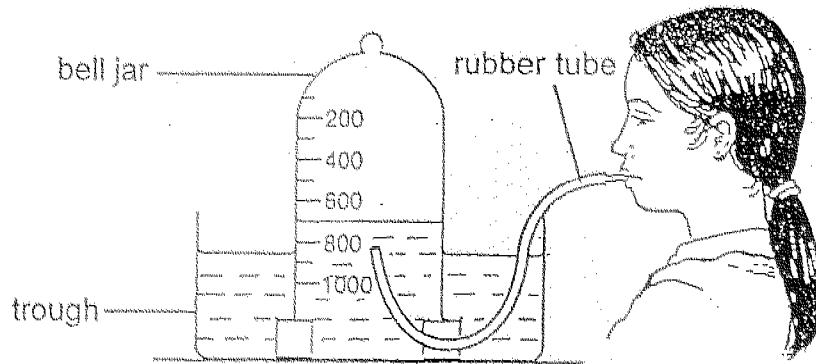

Which of the following changes would she observe when she exhaled into the rubber tube?

- A Bubbles were observed in the water in the bell jar.
- B The water level in the trough rose.
- C The water level in the bell jar rose.
- D Bubbles were observed in the water at the bottom of the trough.

- (1) A and B only
- (2) A and D only
- (3) B and C only
- (4) C and D only

11. The table below shows the oxygen level, number of fish and number of green plants in different rivers flowing through four towns.  
Which town is most likely to be discharging untreated sewage?

| Town | Oxygen level | Number of fish | Number of green plants |
|------|--------------|----------------|------------------------|
| (1)  | High         | Few            | Many                   |
| (2)  | High         | Many           | Many                   |
| (3)  | Low          | Few            | Few                    |
| (4)  | Low          | Many           | Few                    |

12. The diagram shows a rat and how it affects the environment.

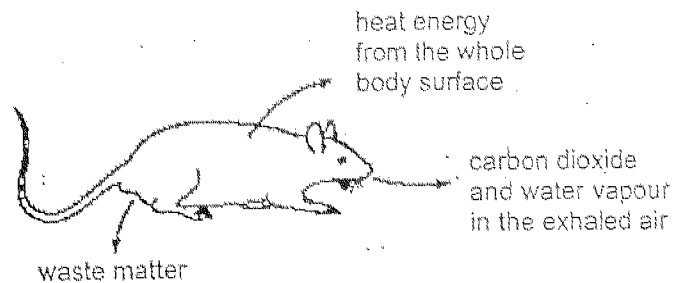

Which of the following will not replenish the natural resources in the environment?

- (1) heat energy
  - (2) water vapour
  - (3) waste matter
  - (4) carbon dioxide
13. The graph below shows the changes in a population of producers and a population of consumers in a lake over a period of time.

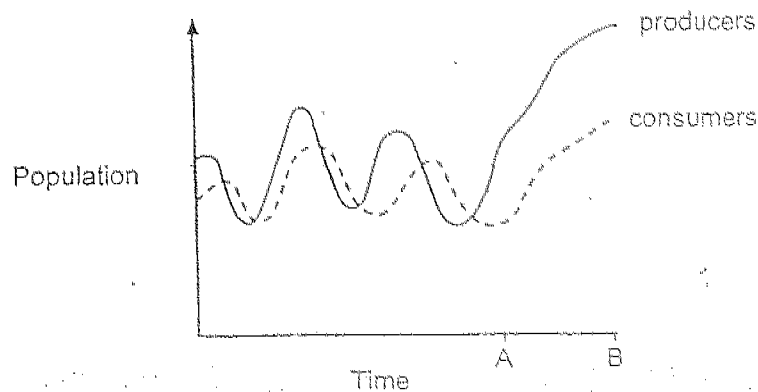

There is a marked increase in the population of producers between time A and time B. Which of the following is the cause of the increase in population?

- (1) The seeds deposited in the lake germinated.
- (2) More producers died because of overcrowding.
- (3) Farming fertiliser was washed into the lake which promoted growth of producers.
- (4) Some consumers died so there were fewer consumers to feed on the producers.



14. Based on the diagrams of the dolphin and fish (not drawn to scale), which statements are true about their adaptations for movement in water?

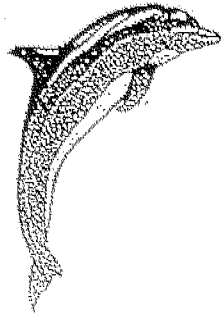

dolphin

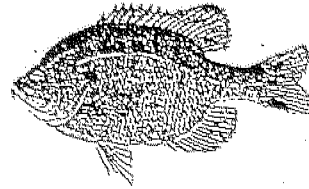

fish

- A Each has a streamlined body shape.
- B Each has a tail to propel itself forward in the water.
- C Each has a swim bladder to keep it afloat in water.
- D Each has a pair of flippers to help it keep balance in water.

- (1) A and B only
- (2) A and D only
- (3) B and C only
- (4) C and D only

15. Three containers, X, Y and Z, were set up as shown below. At the start of the experiment, the carbon dioxide indicator in each container was red. The carbon dioxide indicator changes from red to yellow when exposed to increased amount of carbon dioxide.

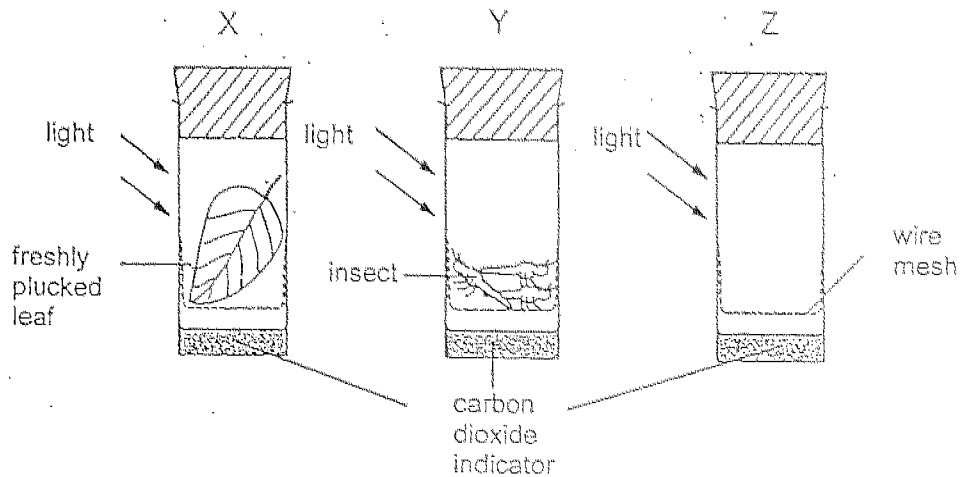

What will be the colour of the carbon dioxide indicator in each container after 3 hours?

|     | Test-tube X | Test-tube Y | Test-tube Z |
|-----|-------------|-------------|-------------|
| (1) | red         | yellow      | yellow      |
| (2) | red         | yellow      | red         |
| (3) | yellow      | red         | red         |
| (4) | yellow      | red         | yellow      |

16. Study the classification chart below.

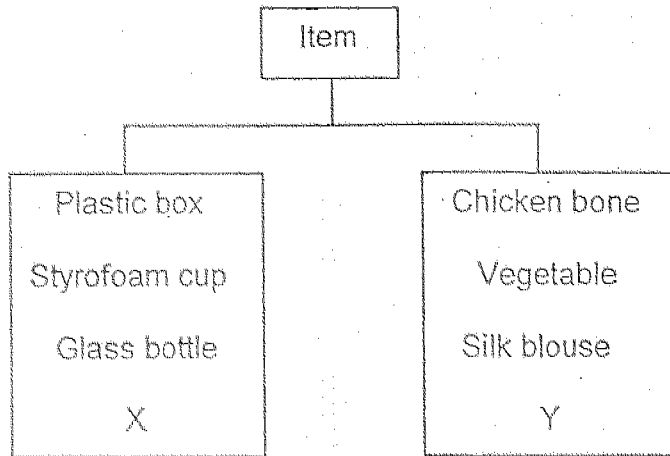

What are X and Y most likely to be ?

|     | X                | Y         |
|-----|------------------|-----------|
| (1) | Ceramic plate    | Newspaper |
| (2) | Prawn shell      | Biscuit   |
| (3) | Metal spoon      | Stone     |
| (4) | Wooden chopstick | Eraser    |

17. The picture below shows the sun as viewed from Earth at daytime during a solar eclipse.

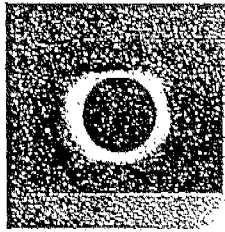

The diagrams below show representations of four different positions of the Earth, Moon and Sun in our solar system.

Which is the correct representation of the solar eclipse?

|     |  |
|-----|--|
| (1) |  |
| (2) |  |
| (3) |  |
| (4) |  |

18. Ali pumped more air into an inflated basketball. He found that it became harder.

Why did it become harder ?

- (1) The air in the basketball has escaped.
- (2) The air in the basketball has expanded.
- (3) The air in the basketball was compressed further.
- (4) The air in the basketball has increased in volume.

19. Jian Hua wanted to find out how adding some substances affect the boiling point of water.

He carried out an experiment as stated below.

| Step | Method  |
|------|---|
| 1    | Add some salt into a beaker of water.                                     |
| 2    | Heat the solution, stirring it continuously until all the salt dissolves. |
| 3    | Measure the boiling point of the solution.                                |
| 4    | Repeat steps 1 to 3 using sugar.  |
| 5    | Repeat steps 1 to 3 using honey.  |

What variables must he keep constant in order to carry out a fair test ?

- A amount of water
- B mass of substance
- C boiling point of the solution
- D initial temperature of the water

- (1) A, B and C only
- (2) A, B and D only
- (3) A, C and D only
- (4) B, C and D only

20. A big block of ice is left to melt on a piece of metal sheet as shown below.

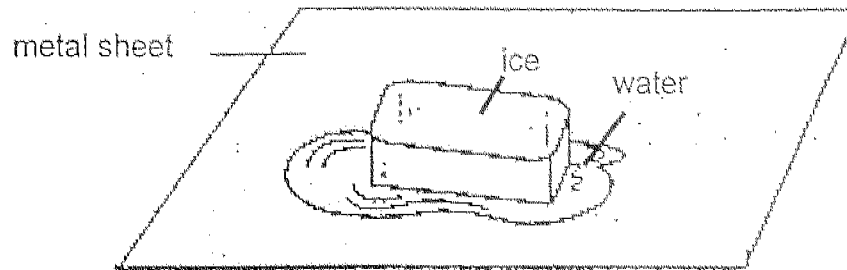

Which of the following statements are true when the ice is melting ?

- A The temperature of the ice decreases.
  - B The metal sheet is losing heat to the ice.
  - C The water is gaining heat from the surroundings.
- (1) A only
  - (2) A and B only
  - (3) B and C only
  - (4) A, B and C
21. Two ring magnets X and Y are put through a rod as shown below.

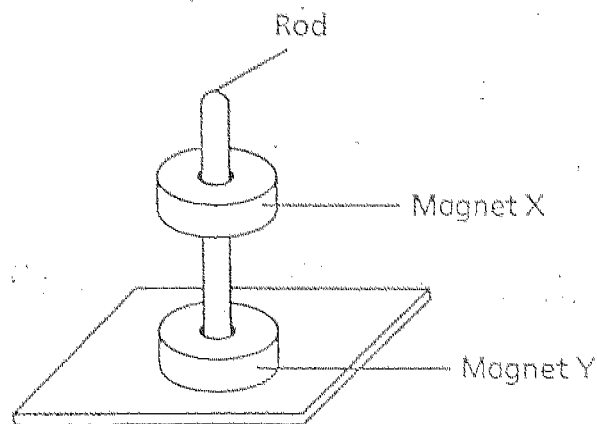

Why is magnet X suspended above magnet Y ?

- (1) The rod is made of steel.
- (2) Magnet Y is a very weak magnet.
- (3) The like poles of both magnets face each other.
- (4) The mass of magnet X is less than the mass of magnet Y.

22. The pie chart below shows the sources of air pollution in a city.

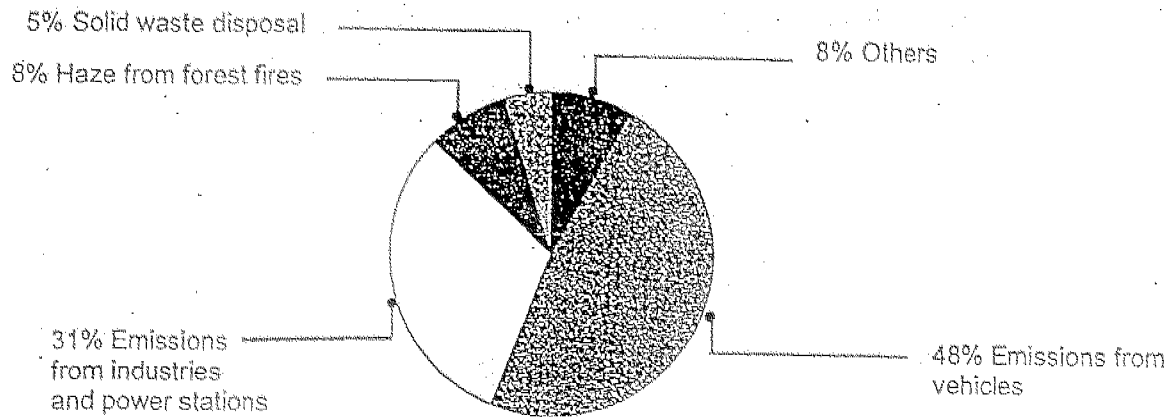

Based on the pie chart, what action will reduce the most amount of air pollution in this city?

- A Cut down more trees.
- B Allocate more land for landfills.
- C Use energy-saving appliances.
- D Use public transport more often.

- (1) A and B only
- (2) B and C only
- (3) C and D only
- (4) A and D only

23. The diagram below shows some human activities which affect the environment.

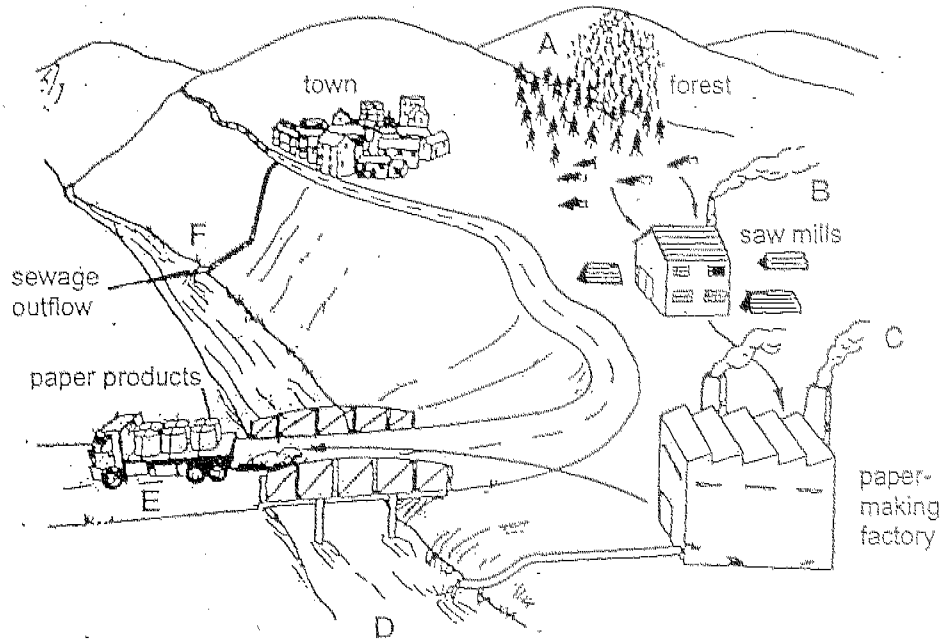

Which human activity/activities is/are the main causes of acid rain?

- (1) A and B only
- (2) B and C only
- (3) D and F only
- (4) E and F only

24. Which is the most suitable material to make a cooking pot?

| Material | Good conductor of heat | High melting point |
|----------|------------------------|--------------------|
| (1)      | ✓                      | ✓                  |
| (2)      | ✓                      | ×                  |
| (3)      | ×                      | ✓                  |
| (4)      | ×                      | ×                  |

Key : ✓ means characteristic present  
 × means characteristic absent



25. Which of the following process(es) show(s) an increase in heat ?

- A melting of butter
- B casting a shadow
- C hardening of liquid wax

- (1) A only
- (2) A and C only
- (3) B and C only
- (4) A, B and C

26. The table below shows the melting points and boiling points of substances A, B, C and D.

| Substance | Melting point ( $^{\circ}\text{C}$ ) | Boiling point ( $^{\circ}\text{C}$ ) |
|-----------|--------------------------------------|--------------------------------------|
| A         | 45                                   | 87                                   |
| B         | 63                                   | 189                                  |
| C         | -5                                   | 28                                   |
| D         | 0                                    | 100                                  |

At room temperature ( $30^{\circ}\text{C}$ ), which of the following observation(s) is/are correct?

- (1) Substance D is in the solid state.
- (2) Substances A and B are in the solid state.
- (3) Substances B and C are in the liquid state.
- (4) Substances A, B and D are in the gaseous state.

27. Study the following set-up carefully.

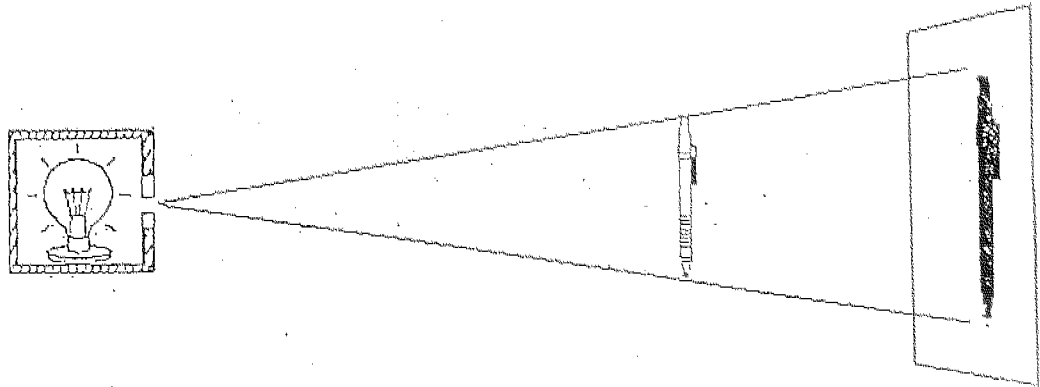

Which of the following shows the correct relationship between the distance of the light source from the pen and the length of the shadow?

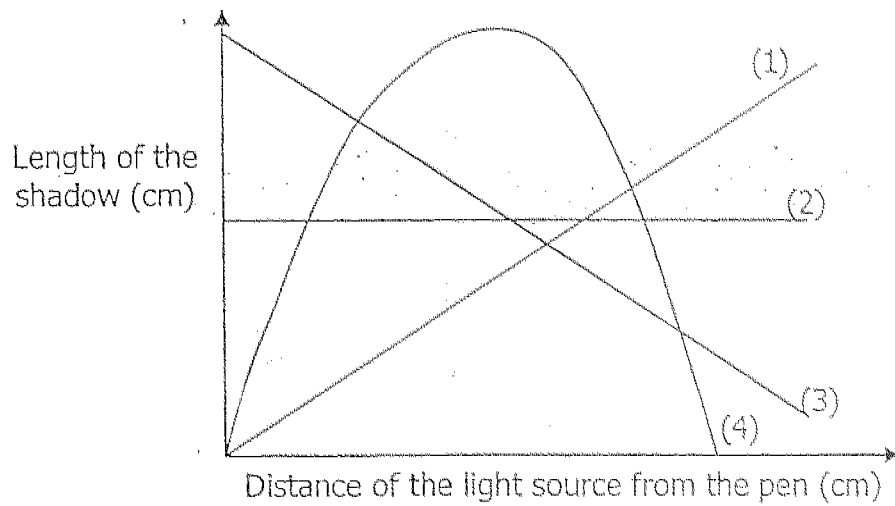

28. Alex placed a mirror on a card with a letter "R". He saw the reflection as shown below.

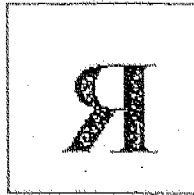

Where was the mirror placed to give this reflection?

(1)

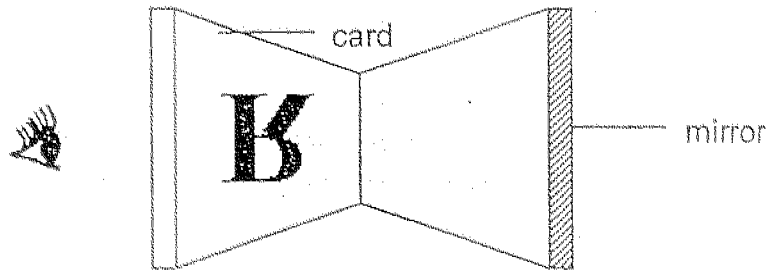

(2)

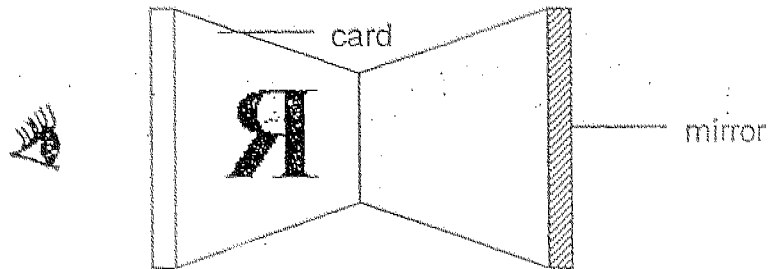

(3)

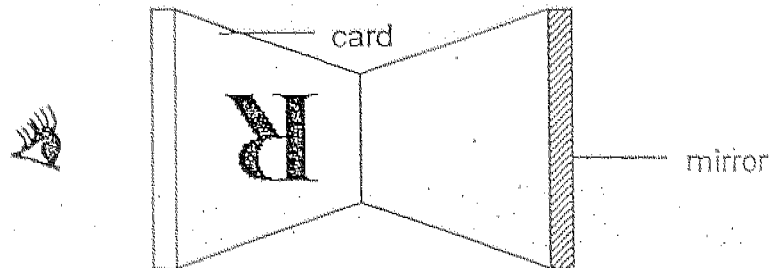

(4)

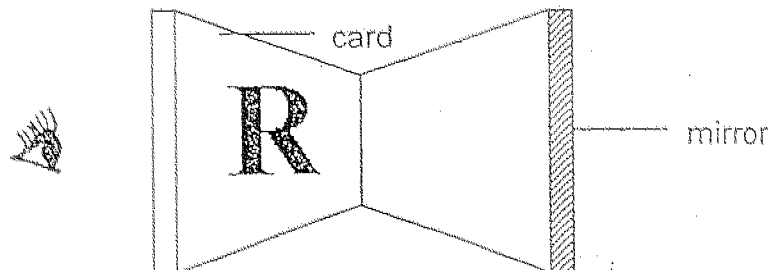

29. Faizal set up an electrical circuit as shown below to find out if a metal ruler can conduct electricity. The bulb did not light up.

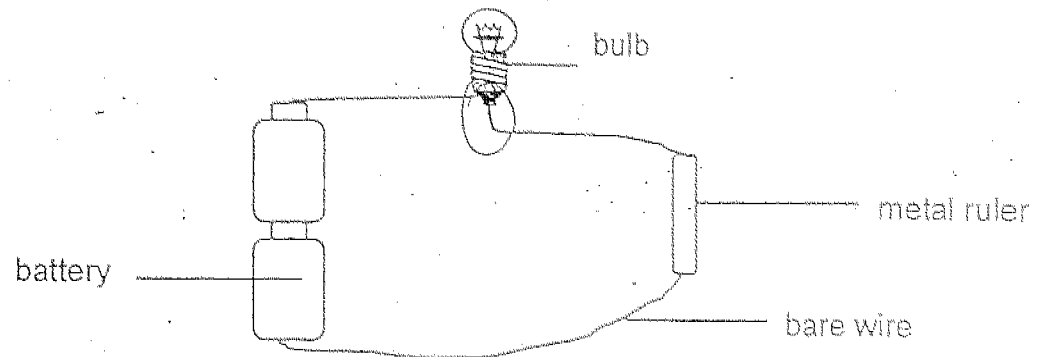

Based on the diagram, which is the most likely reason?

- (1) The bulb is fused.
- (2) Bare wires are used.
- (3) The bulb is connected wrongly.
- (4) The arrangement of the batteries is wrong.

30. Calvin connected four objects W, X, Y and Z to an electrical circuit as in Figure 1.

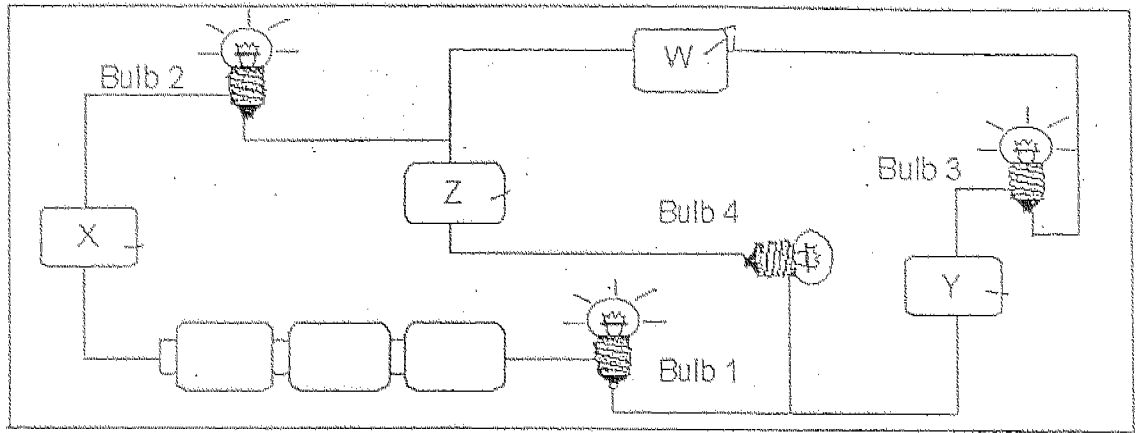

Figure 1

He rearranged the positions of the objects as in Figure 2.

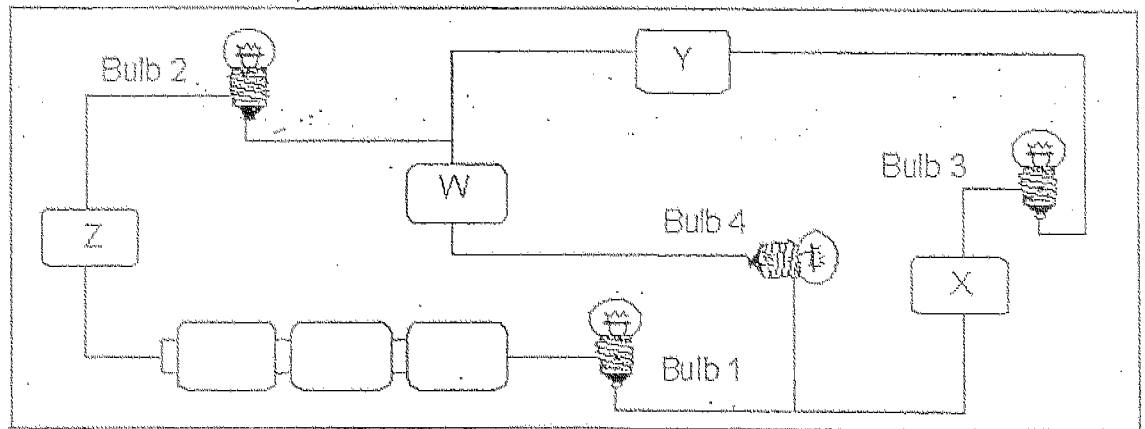

Figure 2

What is most likely to happen in Figure 2?

- (1) Bulbs 1, 2 and 3 will light up.
- (2) Bulbs 1, 2 and 4 will light up.
- (3) All of the bulbs will light up.
- (4) None of the bulbs will light up.

PART II (40 marks)

Answer the following questions in the spaces provided.

31. The diagram shows the longitudinal section of two fruits, W and X (not drawn to scale).

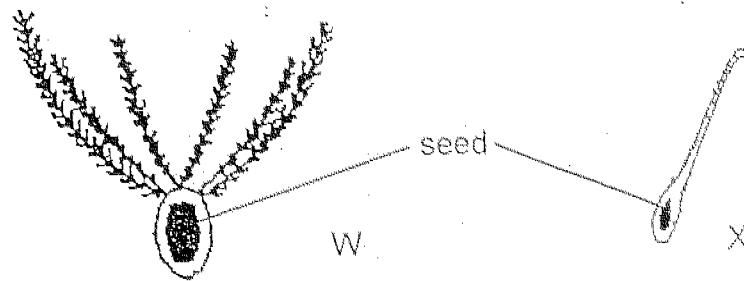

In the table below, suggest how the fruits are dispersed and the structures that aid them in their dispersal. [2]

| Fruit | Method of dispersal | Structure that aids in dispersal |
|-------|---------------------|----------------------------------|
| W     |                     |                                  |
| X     |                     |                                  |

32. Study the following diagram carefully.

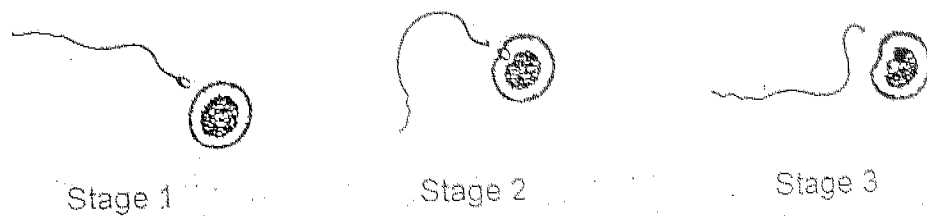

- (a) State the process that has occurred at Stage 3. [1]

\_\_\_\_\_

- (b) In which part of the human body are sperms produced? [1]

\_\_\_\_\_

33. The apparatus shown below can be used to illustrate the action of breathing.

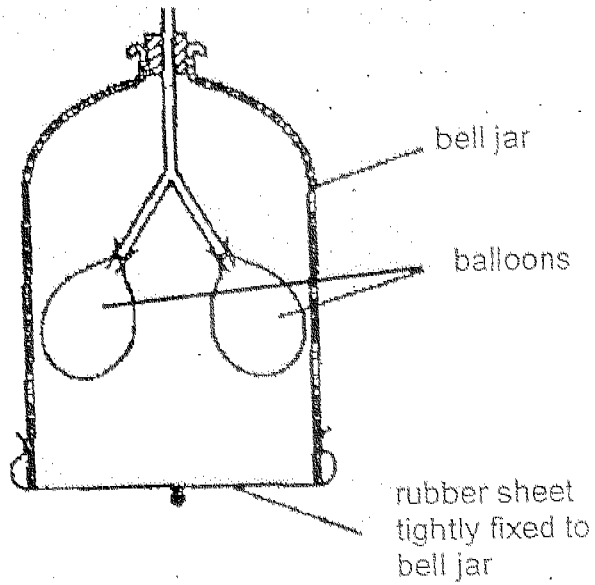

Fill in the boxes with the part of the respiratory system that is represented by each of the apparatus. [3]

|     | Apparatus    | Part of the Respiratory System |
|-----|--------------|--------------------------------|
| (a) | bell jar     |                                |
| (b) | balloons     |                                |
| (c) | rubber sheet |                                |

34. Meiling carried out an experiment using the four set-ups as shown below.

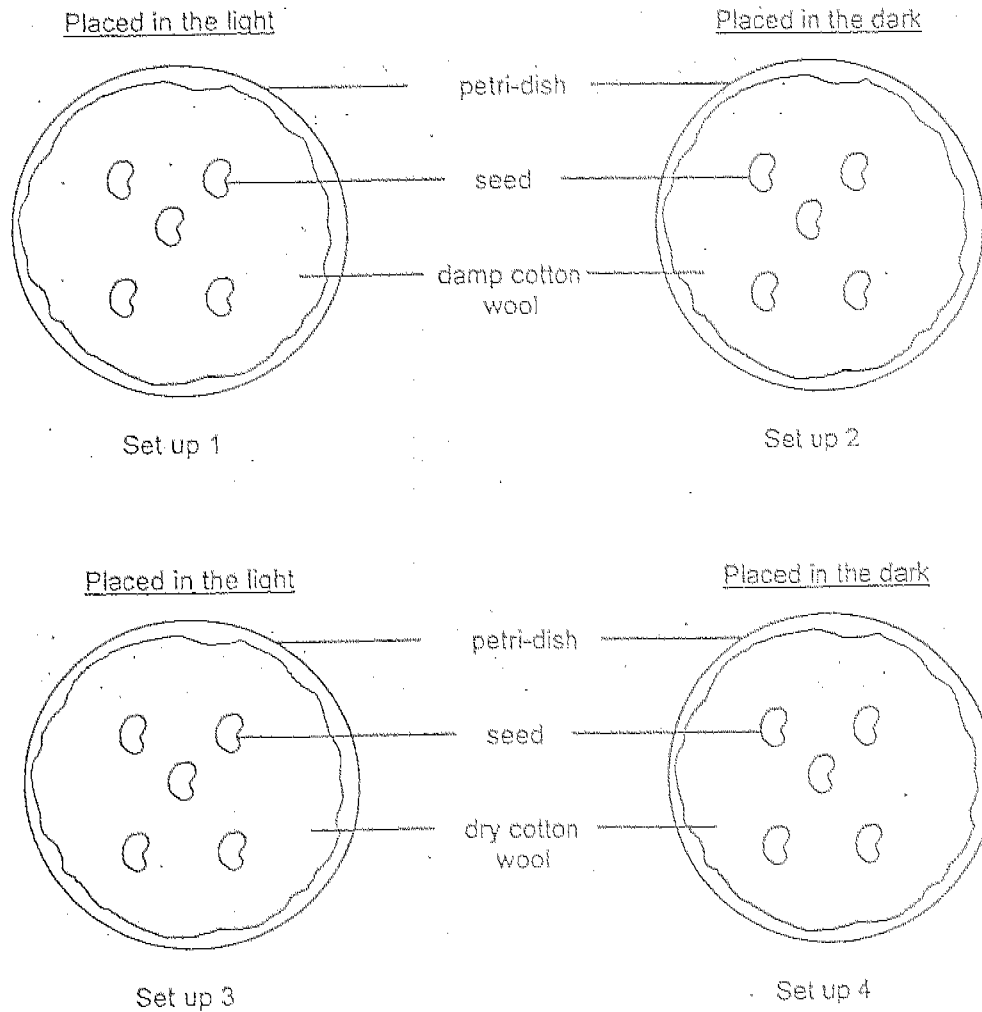

(a) She observed that the seeds in some set-ups germinated. In which set-ups did the seeds germinate? [1]

---

(b) If she wanted to find out whether water is needed for the germination of seeds, which 2 set-ups should she choose for a fair test? [1]

---



35. The diagram below shows the human digestive system.

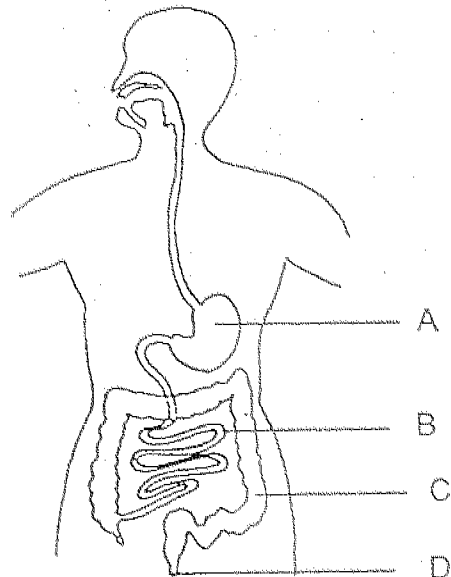

Based on the diagram above and put a tick (✓) in the correct boxes for the following statements. [2]

|     | Statement  | True | False | Not possible to tell |
|-----|--|------|-------|----------------------|
| (a) | Digestion begins at Part A.  |      |       |                      |
| (b) | Part B is the longest part of the digestive system.  |      |       |                      |
| (c) | When a person suffers from diarrhoea it means that Parts B and C are not functioning well. |      |       |                      |
| (d) | Human waste leaves the body through Part D   |      |       |                      |

36. The graph shows the number of people suffering from a particular disease over a number of years. Penicillin ( an antibiotic ) is made available to treat the disease, caused by a certain type of bacteria, at time A.

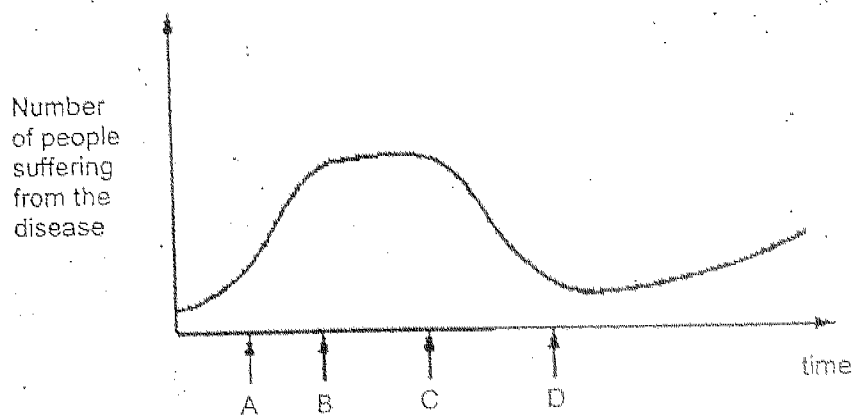

- (a) Based on the graph, describe the effect of the use of the antibiotic on the number of people suffering from the disease between time C and D. [1]

---

---

- (b) Suggest a reason for the increase in the number of people suffering from the disease after time D. [2]

---

---

37. In the diagram, the arrows A, B, and C represent different forms of energy.

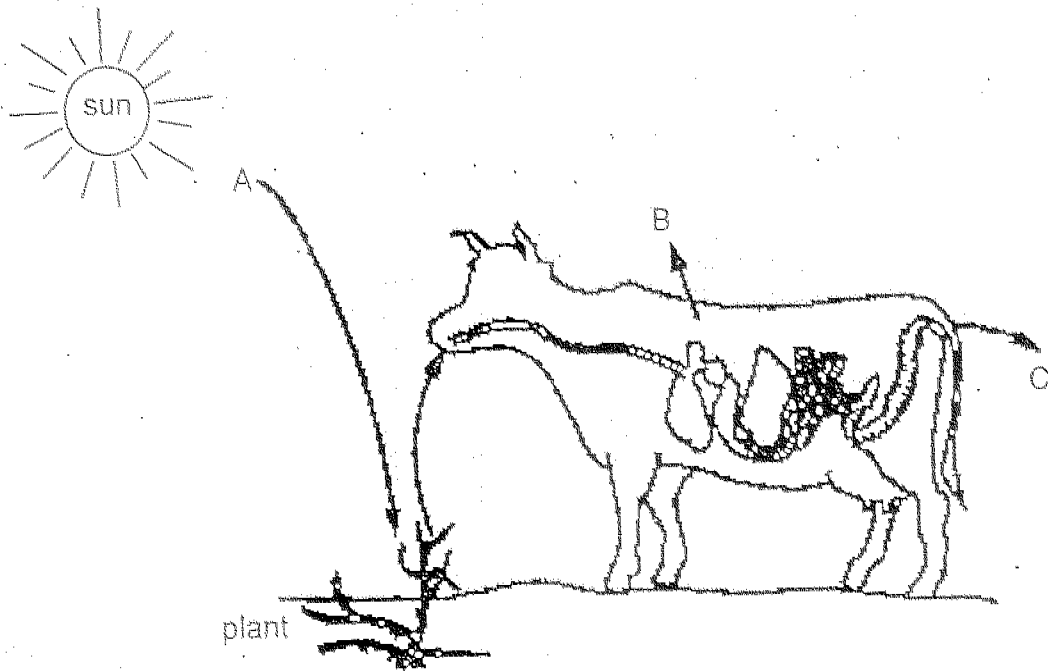

(a) State the forms of energy represented by the following letters. [2]

(i) A \_\_\_\_\_

(ii) B \_\_\_\_\_

(c) Identify the type of organism that might use the energy given out by the cow at C. [1]

\_\_\_\_\_

38. The diagram below shows three types of fishes P, Q and R. The fishes live amongst water plants in a river. A predator of the 3 types of fishes is introduced into the river.

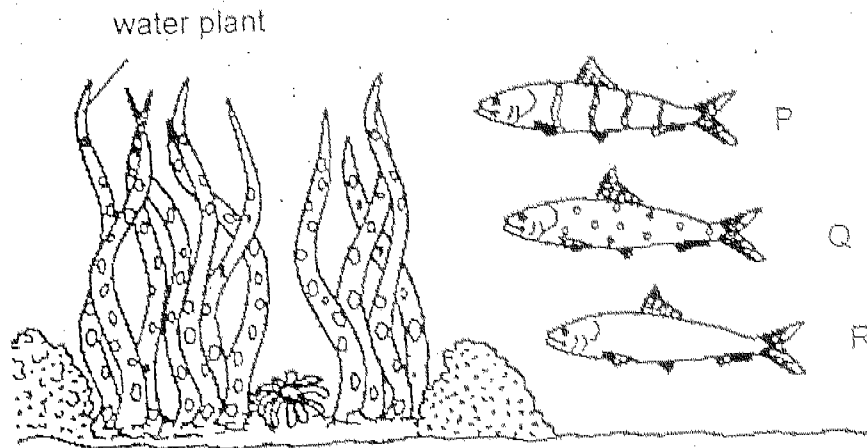

- (a) Based on the diagram, which fish P, Q, or R would most likely have the greatest decrease in number? Explain your answer. [2]

---



---



---

- (b) After a few years, a similar-sized fourth type of fish S appeared in the river and began to increase in number more than all the other 3 types of fishes.

In the diagram below, draw the likely body pattern of Fish S. [1]

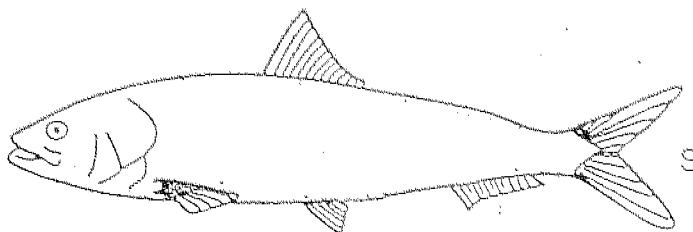

39. Two objects A and B are hung on a rod with the help of a lit candle as shown in the diagram below. Object B is a hollow cone made of cardboard.

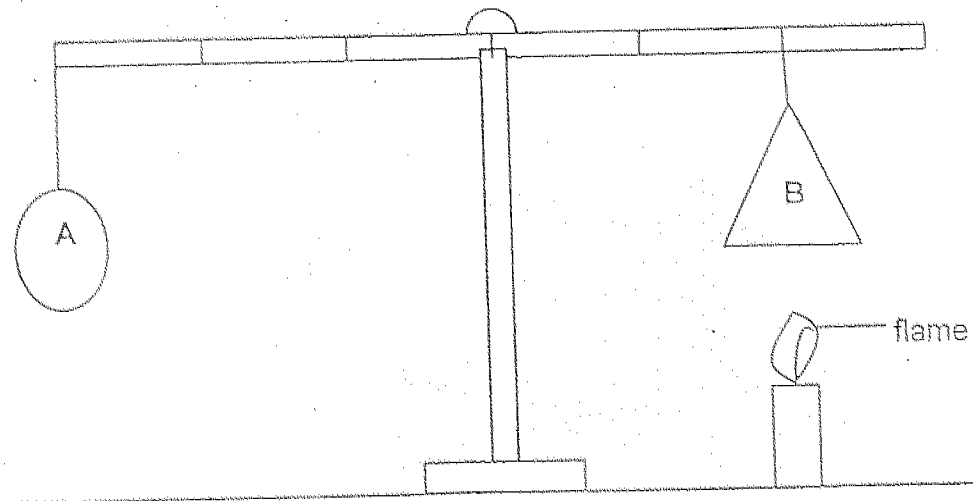

- (a) What would happen to the lever when the candle flame is removed? [1]

---

- (b) What can you say about the mass of object A as compared to the mass of object B? [2]

---

---

40. Three wheel and axle systems, X, Y and Z, are used to lift the same load. They are drawn to scale.

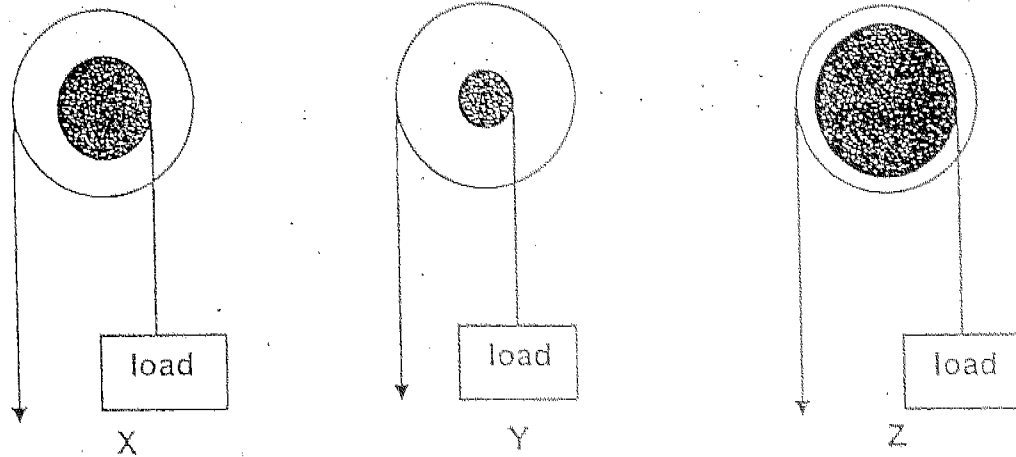

- (a) The table below shows the different amount of effort needed when using the 3 wheel and axle systems. Complete the table with the appropriate wheel and axle system X, Y or Z that corresponds with the effort needed.

[1]

| Wheel and axle system | Effort needed to lift the load |
|-----------------------|--------------------------------|
|                       | 12                             |
|                       | 5                              |
|                       | 9                              |

- (b) Arrange the wheel and axle systems above in ascending order of the distance moved by the effort when the load moved the same distance. [1]

---

41. Complete the passage below by filling each of the blanks with an appropriate word. [2]

Carbon dioxide, a \_\_\_\_\_ gas traps the heat from the Sun and prevents it from escaping back into space easily. When the amount of this gas increases excessively, the temperature of the Earth will \_\_\_\_\_, leading to global warming. More polar ice will melt, the sea level will \_\_\_\_\_ and bring about \_\_\_\_\_ in low-lying areas.

42. Hamza and Jason carried out an experiment to find out how the mass of an object affects the length of a spring when the object is hung on it. They recorded their results and plotted the graph below.

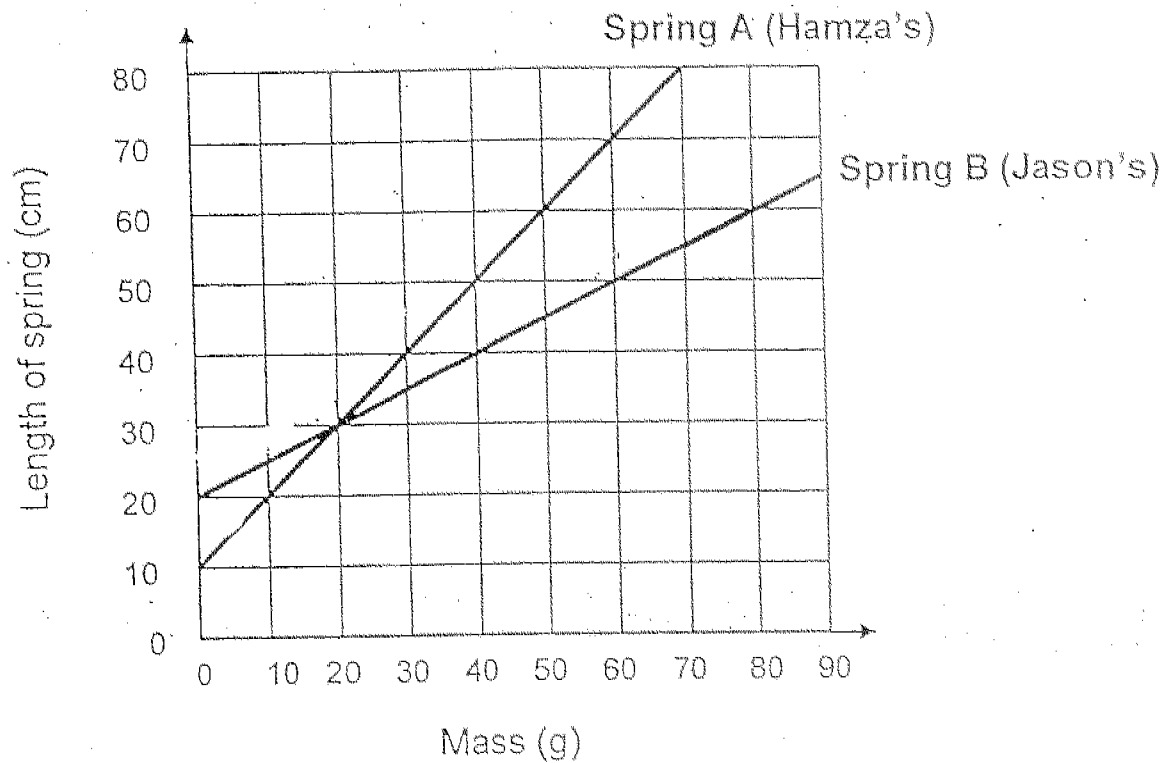

- (a) What is the mass of the object when their springs are of the same length? [1]

---

- (b) Find the extension of Spring B when an object with a mass of 60g is hung on it. [1]

---

- (c) Who has a stronger spring?  
How could you tell that his spring was stronger? [2]

---



---



43. Complete the classification chart below with suitable words.

[2]

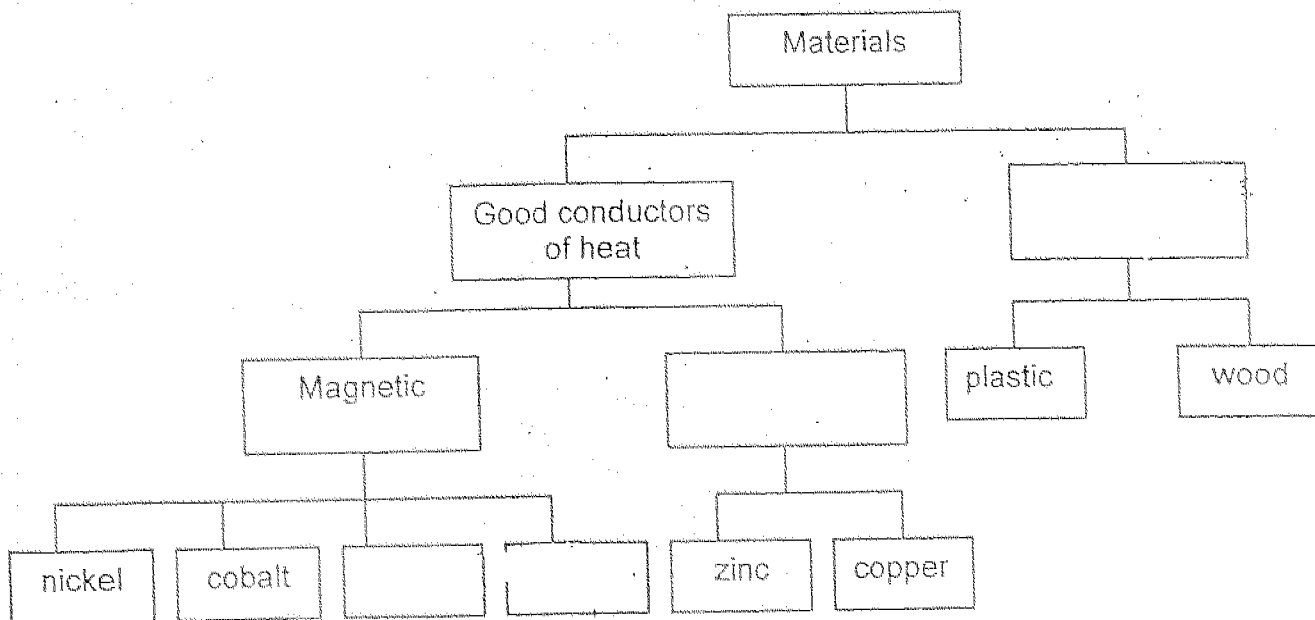

44. The diagram below shows the movement of a ball when it bounces.

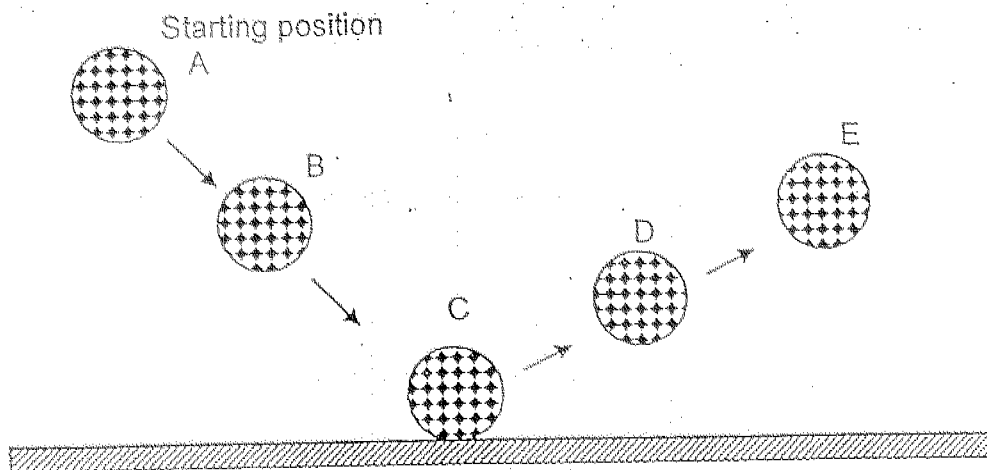

(a) State the position(s) where the ball has the least gravitational potential energy.

[1]

(b) State the energy conversion from Position A to Position C.

[1]

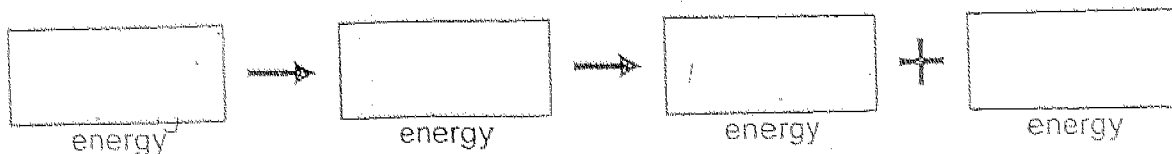

45. Josephine covered three similar tins A, B and C with different coloured paper. She put a thermometer in each tin and left the tins in the sun. She recorded the temperature of the air in the tins every two minutes.

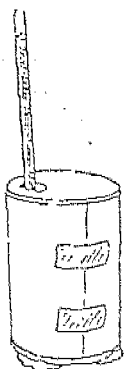

Tin A covered with white paper

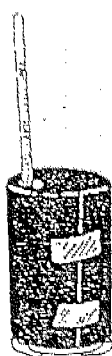

Tin B covered with black paper



Tin C covered with red paper

She recorded the results in the table below.

| Time (min) | Temperature ( $^{\circ}\text{C}$ ) |       |       |
|------------|------------------------------------|-------|-------|
|            | Tin A                              | Tin B | Tin C |
| 0          | 28.0                               | 28.0  | 28.0  |
| 2          | 28.0                               | 29.0  | 28.5  |
| 4          | 28.5                               | 30.5  | 29.0  |
| 6          | 29.0                               | 31.0  | 29.5  |
| 8          | 29.0                               | 32.0  | 29.5  |
| 10         | 29.5                               | 32.5  | 30.5  |

- (a) What was the aim of Josephine's experiment? [1]

---



---

- (b) What is the relationship between the temperature of the air in the tin and the colour of the paper? [1]

---



---

46. Michael and his three friends observed a kettle of water boiling and each of them made an inference.

Michael : The steam has kinetic energy.  
Shaun : There is more water vapour in the air now.  
Clement : The temperature of the boiling water is rising.  
Mathias : The mist coming out from the spout is in the gaseous state.

- (a) Which two boys made the correct inferences? [1]

---

- (b) Explain why the other two inferences were wrong. [2]

---

---

---

End of Paper

HOKKIEN HUAY KUAN 5-SCHOOL PRIMARY 6  
COMBINED PRELIMINARY EXAMINATION II  
SCIENCE

- 1) 2                    27) 3  
2) 1                    28) 4  
3) 2                    29) 3  
4) 3                    30) 4  
5) 1                    31) Animal's fur  
6) 2                           Hair like structure to float in air.  
7) 4                    32) a) Fertilization  
8) 4                           b) Testes  
9) 2                    33) a) rib-cage  
10) 1                           b) lungs  
11) 3                           c) diaphragm  
12) 1                    34) a) Set-ups 1 and 2  
13) 3                           b) Set-ups 1 and 3  
14) 1                    35) a) False  
15) 2                           b) True  
16) 1                           c) Not possible to tell  
17) 3                           d) True  
18) 3                    36) The use of the antibiotic decreases the number  
19) 2                           of people suffering from the disease.  
20) 3                           b) The bacteria has become resistant to the  
   penicillin.  
21) 3                    37) a) i) Light energy  
22) 3                           ii) Heat energy  
23) 2                           c) Decomposer  
24) 1                    38) a) R. R does not have any patterns on its  
25) 1                           body to help it to camouflage so it is  
   easily spotted by predators.  
26) 2                           b)

39) a) The lever will tilt downwards at the end where B is.

b) A is lighter than B.

40) a) Z

Y

X

b) Z X Y

41) greenhouse

increase

rise

floods

42) a) 20 g

b) 30 cm

c) Jason. For the same mass, Jason's spring stretched less than Hamza's spring

43) Poor conductors of heat

Non-magnetic

iron steel

44) a) C

b) Gravitational potential kinetic heat sound

45) a) It is to find out which coloured paper absorbs the most heat.

b) The darker the colour of the paper covering the tin, the higher the temperature of the air inside the tin.

46) a) Michael and Shawn.

b) Temperature of boiling water remains the same at  $100^{\circ}\text{C}$   
The mist is liquid state as it is tiny water droplets.

38b)

