

SAT



**CATHOLIC HIGH SCHOOL
PRIMARY SIX
MID YEAR EXAMINATION, 2005**

**SCIENCE
EM 1 / EM 2**

Name: _____ ()

Class : Primary 6 _____

Date : 19 May 2005

BOOKLET A

30 Questions
60 Marks

Total Time for Booklets A & B : 1 hour 45 minutes

Instructions to Candidates

Do not open this booklet until you are told to do so.
Follow all instructions carefully.
Answer all questions.

Section A: Multiple Choice Questions (60 marks)

For each question from 1 to 30, four options are given. One of them is the most suitable answer. Make your choice (1, 2, 3 or 4) on the Optical Answer Sheet.

1. The table below shows how some muscles have been classified. Which of the muscles listed below has been classified correctly?

	Muscles that you can control	Muscles that you cannot control
(1)	Leg	Finger
(2)	Neck	Heart
(3)	Stomach	Heart
(4)	Arm	Leg

2. Some animals carry their young inside the mother's body for a period of time before birth. This period is called gestation.

The table below shows the gestation period of mammals and the mass of their young when it is born.

Animal	Gestation (weeks)	Average mass of new-born baby (kg)
Mouse	2.5	0.005
Cat	8	0.25
Pig	?	1.5
Human	40	3.5
Horse	49	36
Elephant	95	100

What is the most likely gestation period of a pig?

- (1) 3 weeks
- (2) 9 weeks
- (3) 40 weeks
- (4) 45 weeks

3. A small plant with roots and leaves is put into a beaker of red-coloured water. After a day, it was observed that the stem and leaves had turned red. What does this show?

- A The leaves are making food and water.
- B The leaves carry the water to the other parts of the plant.
- C The water from the roots is carried all the way to the leaves.
- D The water-carrying tubes are present in roots, the stem and in the leaves.

- (1) A and B only
- (2) B and C only
- (3) C and D only
- (4) A and D only

4. The flowchart shows some parts of a body system. X and Y are substances found in blood taken from the small intestine.

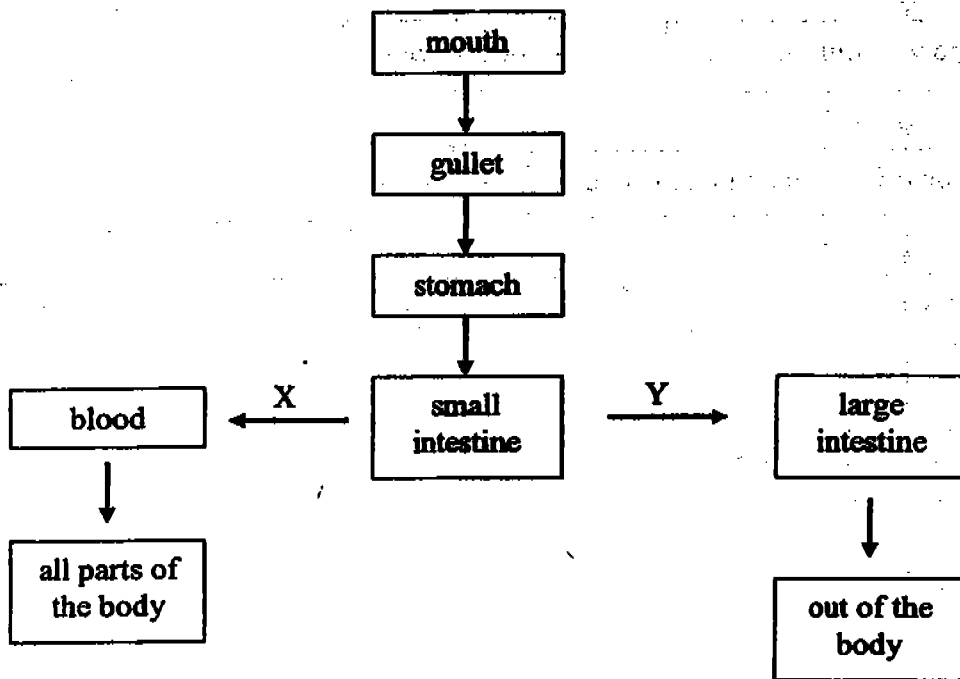

What do X and Y represent?

	X	Y
(1)	Water	Undigested food
(2)	Oxygen	Carbon dioxide
(3)	Digested food	Carbon dioxide
(4)	Digested food	Undigested food

5. The following are statements about sexual reproduction in animals.

- A Pollination occurs before fertilisation.
- B They have male and female reproductive parts.
- C Characteristics of the parents are passed on to the young.
- D Fertilisation occurs when the male sex cell fuses with the egg.

Which of the following statements are true?

- (1) A and C only
- (2) B and D only
- (3) A, B and C only
- (4) B, C and D only

6. The flowchart below shows some characteristics of plants A, B, C, D and E.

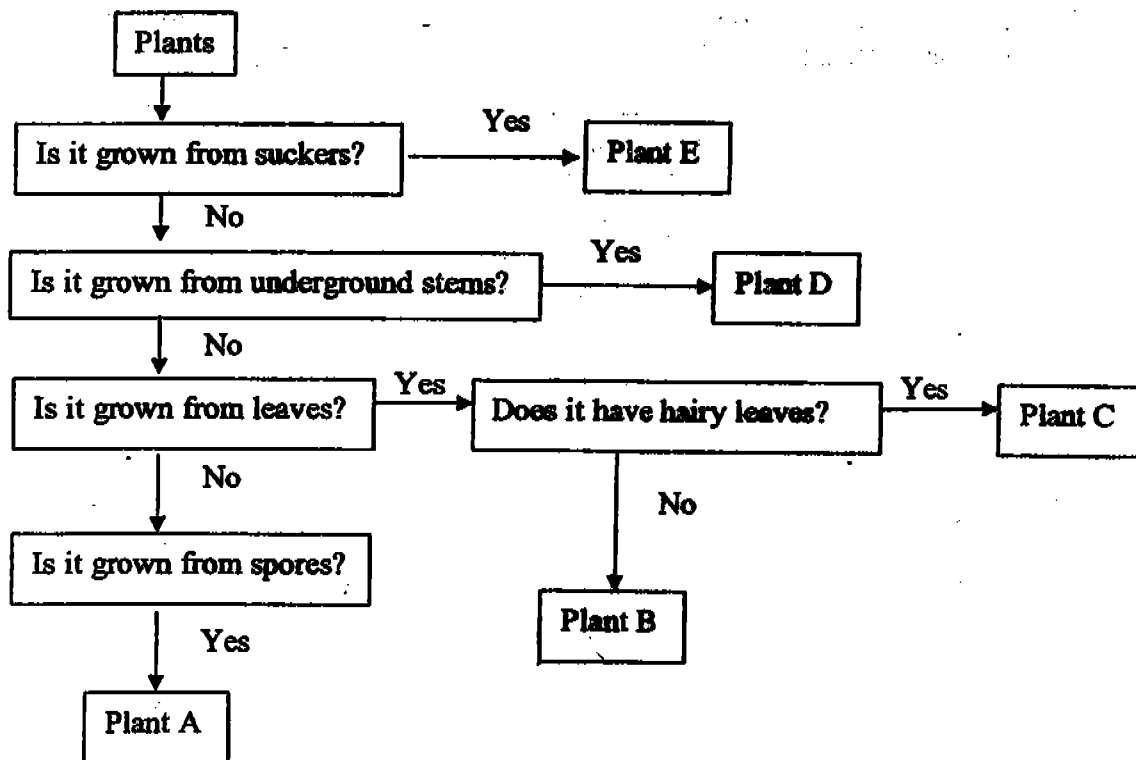

Use the information from the flowchart to match the plants listed in the table below.

	Plant A	Plant B	Plant C	Plant D	Plant E
(1)	Mould	Begonia	Rose	Sweet Potato	Bamboo
(2)	Fern	African violet	Begonia	Carrot	Banana
(3)	Mould	Water chestnut	Bryophyllum	Ginger	Potato
(4)	Moss	Bryophyllum	African violet	Ginger	Pineapple

7. The Venn diagrams below show the comparison of how some animals move. Which one of them shows the correct comparison?

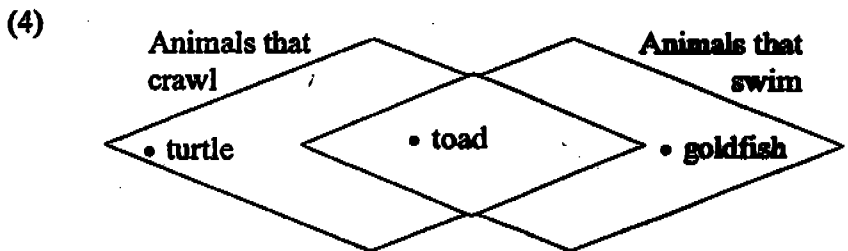
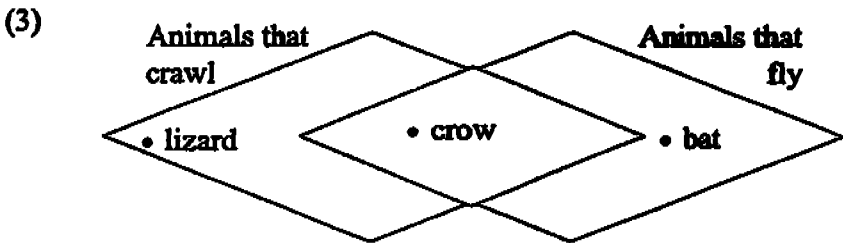
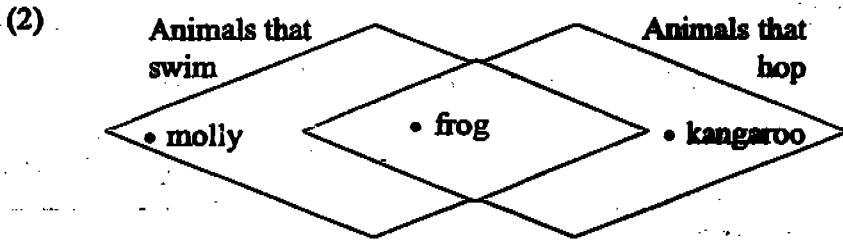
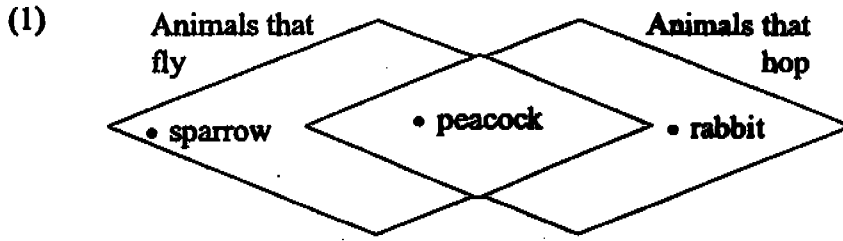

8. The diagrams below show the teeth of Animal X and Animal Y.



Animal X



Animal Y

Examples of Animal X	Examples of Animal Y
Snake	Cow
Lion	Sheep

Which of the following deductions about Animals X and Y is/are correct?

	True	False	Not Possible to Tell
A Animal X eats only plants.			✓
B Animal Y is a herbivore.	✓		
C Animal X hunts in a group.			✓
D Animal Y only eats plants on land.		✓	

- (1) A only
- (2) B only
- (3) A and D only
- (4) B and C only

9. Jiemin transferred a pot of rose plants to a sunny part of her yard which was covered with grass. She watered both the rose plants and grass daily. A few days later, she discovered that the grass that was covered by the pot had turned yellow while the rose plants in the pot grew healthily. She gave the following reasons to explain why the grass had turned yellow:

- A The grass did not receive enough water as the rose plants compete with it for water.
- B The grass had turned yellow as the minerals salts were all absorbed by the rose plants.
- C The grass could not photosynthesize, hence it turned yellow.

Which of the above reason is/are correct?

- (1) B only
- (2) C only
- (3) A and B only
- (4) B and C only

10. James wanted to find out which type of soil is suitable for growing balsam, cactus and lotus. He then collected 3 different types of soil A, B and C and placed them each in a funnel lined with filter paper.

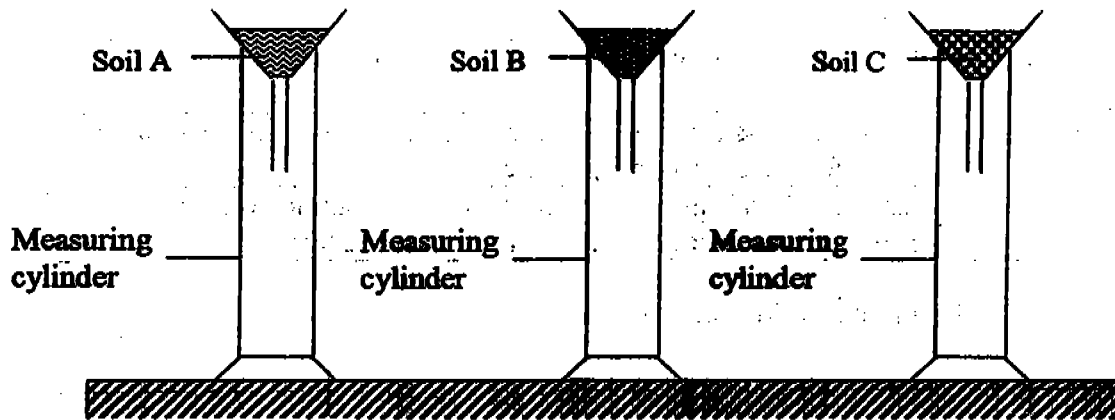

After that he poured 50ml of water into each funnel and timed how long it took for the water to completely flow into each measuring cylinder. The table below shows the results of his investigation.

	Soil A	Soil B	Soil C
Time taken to collect the water.	6min 21sec	35sec	20min
Amount of water collected.	22ml	45ml	5.5ml

Based on the information given, choose the most suitable soil for each of the plant below.

	Soil A	Soil B	Soil C
(1)	Balsam	Cactus	Lotus
(2)	Balsam	Lotus	Cactus
(3)	Lotus	Balsam	Cactus
(4)	Lotus	Cactus	Balsam

11. Some pupils observed that more birds visited the field soon after the grass is mowed. They then made the following comments:

WeiZhong:	The birds are feeding on the cut grass since it is now easier for them to swallow.
XiuPing :	The birds are eating the insects that have been killed during the mowing.
Muthu:	Since the grass is shorter now, the insects are exposed, making it easier for the birds to prey on them.
Joseph:	After the field is mowed the earthworms are attracted to the brighter soil surface, this is what attracted the birds.

Whose explanation(s) is/are correct?

- (1) Muthu only
- (2) WeiZhong only
- (3) XiuPing and Muthu only
- (4) WeiZhong and Joseph only

12. Some scientists made a study of a certain deer population in a grassland habitat over a period of a year. (A grassland habitat is a flat plain with mostly grass, shrubs and very few trees growing on it.) They also recorded the amount of rainfall and temperature of the area throughout the year.

The information they gathered are shown below from (i) to (iv):

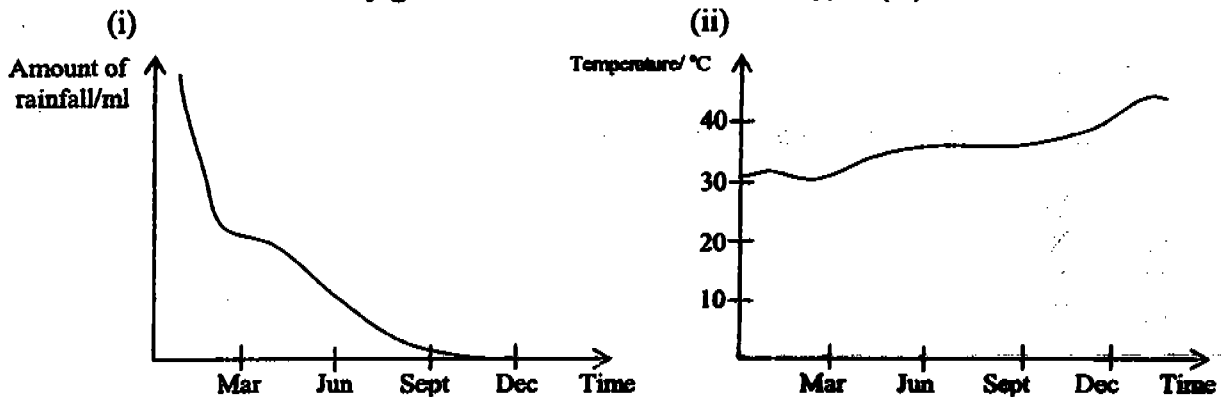

(iii)	Herbivores		Carnivores		Omnivores	
	Before	After	Before	After	Before	After
Number of population counted at the beginning and end of the 1 year	5	6	3	5	2	5
Total number of animals at the beginning and end of the 1 year	339	340	23	25	40	45

(iv) They also found a species of fungi in plants that wiped out all the shrubs but caused no harm to the herbivores which ate them.

The scientists then used a concept map to trace the cause in the decrease in the deer population they were interested in.

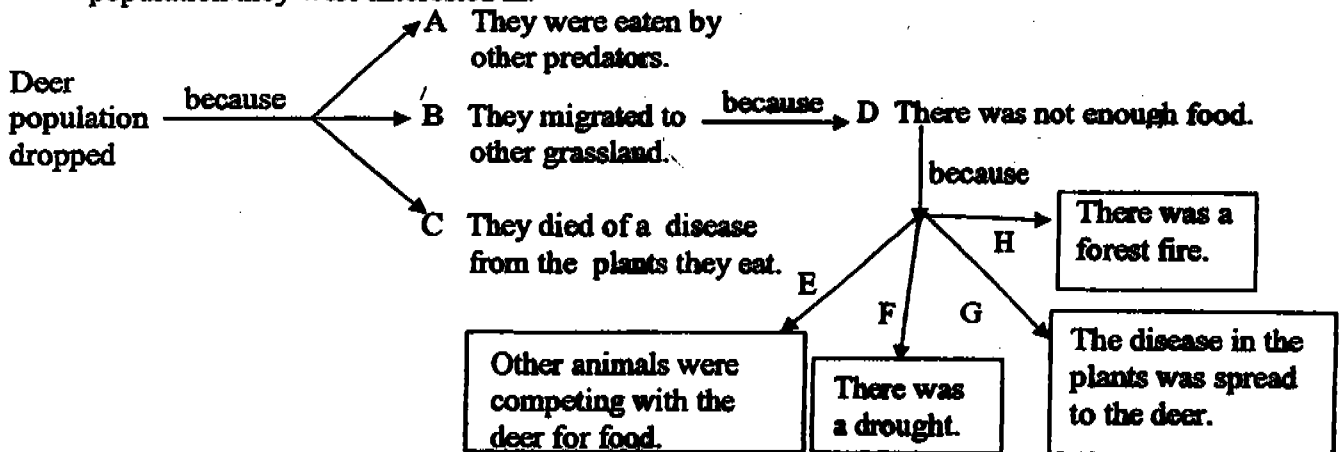

Base on the information given, select the reasons which correctly explain why the deer population dropped.

- (1) A, B, D and H only
- (2) A, B, E and F only
- (3) A, B, D, E, and F only
- (4) A, B, C, D, F and G only

13. The following diagram shows part of the energy path in an eco-system, where W, X, Y and Z represent organisms in it.

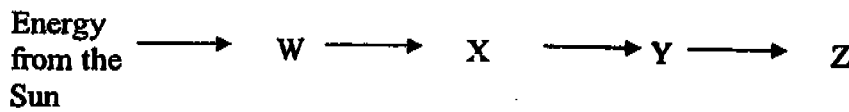

The organism that is a herbivore is most likely to be represented by _____.

- (1) W
- (2) X
- (3) Y
- (4) Z

14. The graph below shows the change in the population of frogs near a pond.

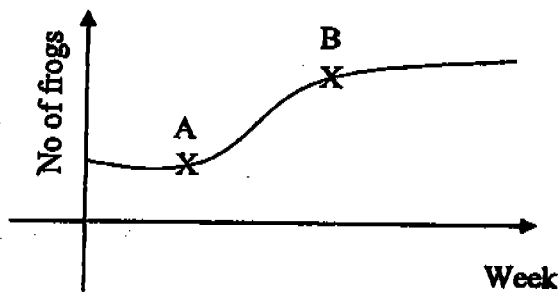

Which of the following events are possible causes for the change in the population of frogs from point A to B?

- A A significant decrease in the water level of the pond.
- B A significant decrease in the number of fish in the pond. eat tadpoles
- C A significant decrease in the number of dragonfly nymphs in the pond.
- D A significant decrease in the number of disease-causing organisms that kill the prey of the frogs.

- (1) A and C only
- (2) B and C only
- (3) A, C and D only
- (4) B, C and D only

15. Kamal wants to find out what gas would be released when cooked rice turns bad. Which of the following set up should he use?

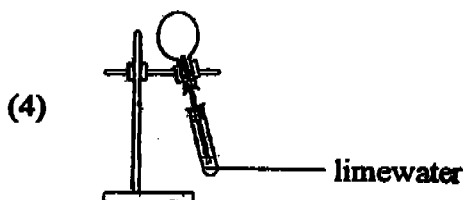
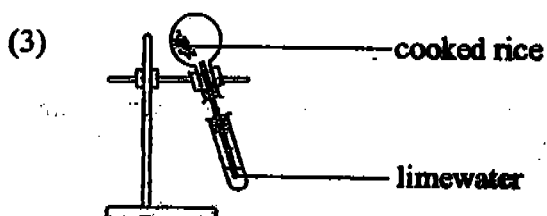
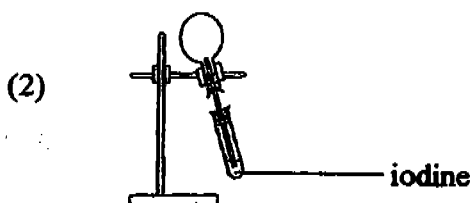
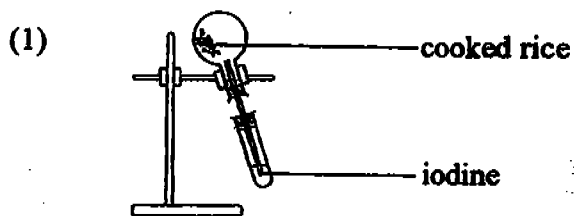

16. Study the diagrams below.

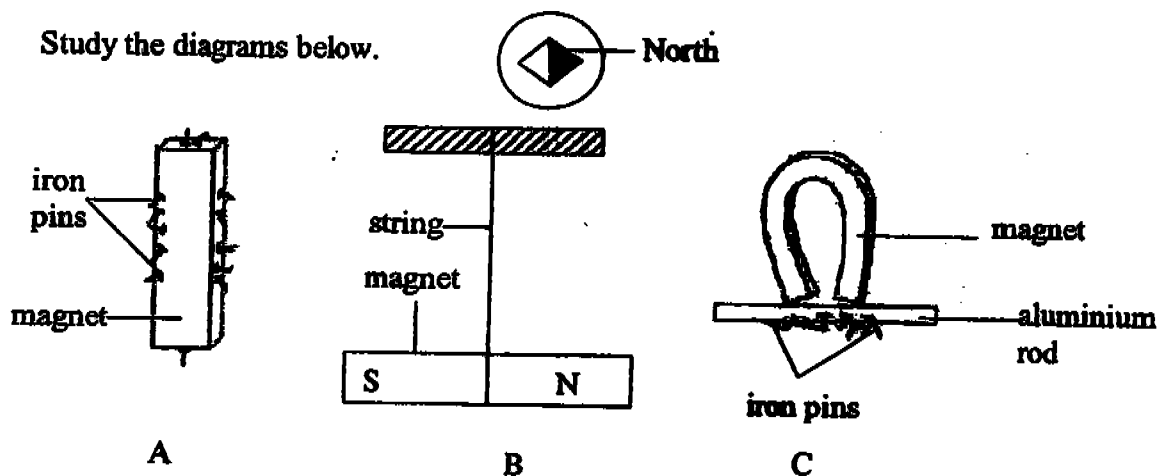

Which diagram(s) correctly show(s) the property/properties of a magnet?

- (1) A only
 (2) C only
 (3) B and C only
 (4) A, B and C

17. The diagram on the right shows a compass.



Two compasses are placed near a bar magnet. Which one of the following diagrams shows the correct positions of the needles?

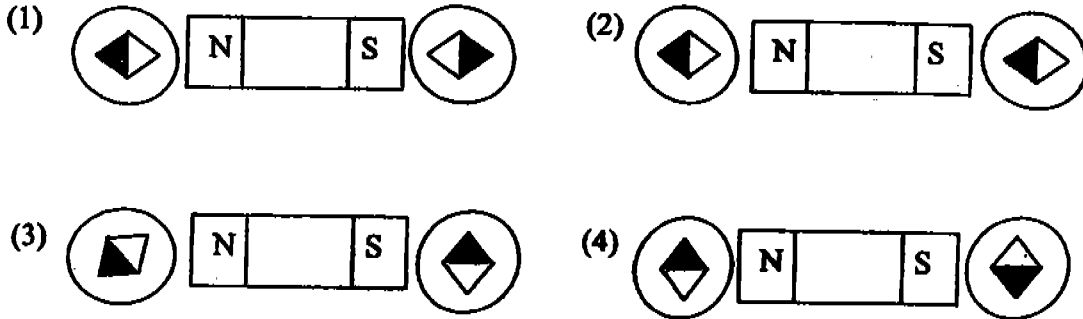

18. Farid placed a sundial in a sunny place. He marked on a piece of paper shadows of the marker at different times of the day.

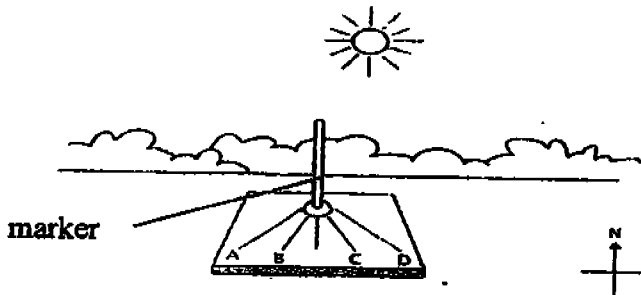

Which one of the following A, B, C or D was the shadow at 8a.m.?

- (1) A
- (2) B
- (3) C
- (4) D

19. Samey placed the 4 setups shown below in the sun. Which one of the thermometers in the set ups below will register the highest reading after 3 hours?

✓ (1)

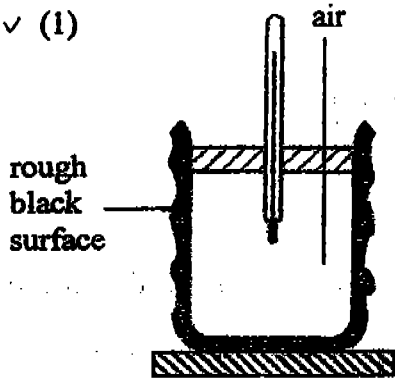

(2)

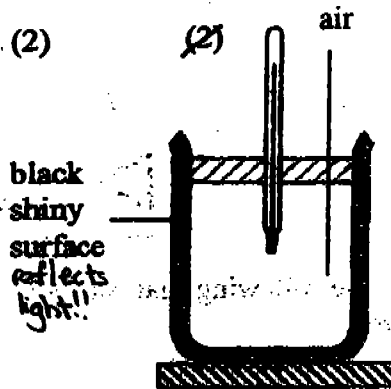

(3)

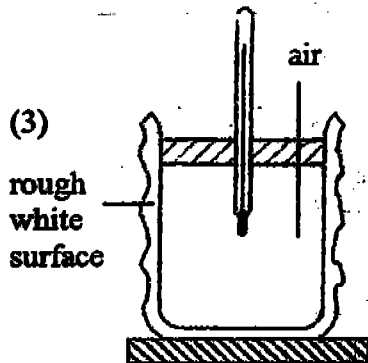

(4)

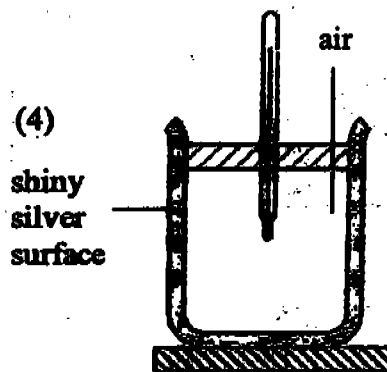

20. Kumar connected a circuit tester to the circuit card on the right and the bulb lights up.

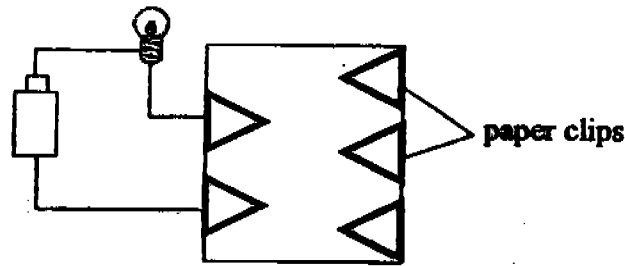

Which one of the following diagrams shows the correct connection on the back of the circuit card?

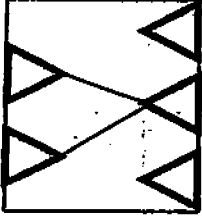
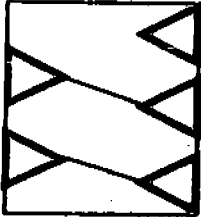
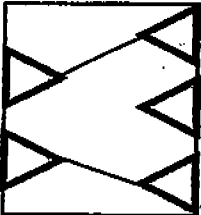
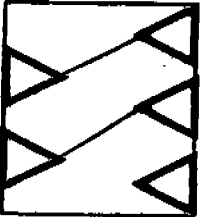
- (1) 
- (2) 
- (3) 
- (4) 

21. The diagram below shows 2 gears linked by a belt. When gear A turns anti-clockwise, gear B will turn _____.

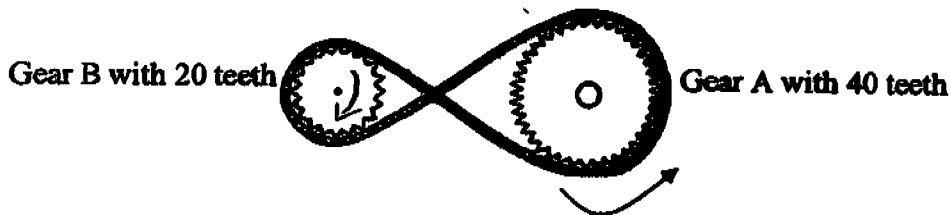

- (1) in the same direction but twice as fast as gear A
 (2) in the opposite direction but twice as fast as gear A
 (3) in the same direction and at the same speed as gear A
 (4) in the opposite direction and at the same speed as gear A

22. Ali set up an experiment with the following steps:

Step 1: An equal amount of water was poured into a basin.

Step 2: 4 pieces of materials of the same size, A, B, C and D were placed in the basin.

Step 3: After 2 minutes, each material was squeezed and the amount of water extracted was collected and weighed.

Ali was trying to find out which material A, B, C or D is _____.

- (1) the strongest
- (2) the most elastic
- (3) the most flexible
- (4) the most absorbent

23. Minah wants to conduct an experiment to find the strength of one type of plastic. Which one of the following methods can help her?

- (1) Use her finger to feel if the plastic is smooth or rough.
- (2) Scratch each piece of plastic with the tip of an iron nail and measure the thickness of each marking made.
- (3) Fix one end of each piece of plastic to the table and add weights at the other end to find out the amount of weights needed before it breaks.
- (4) Hold up the piece of plastic and see the amount of light passing through.

24. Which of the following are not suitable sources of energy?

- A Food
- B Oven
- C Geyser
- D Volcano
- E Electric fan

- (1) B and E only
- (2) A, B and E only
- (3) A, C, D and E only
- (4) B, C, D and E only

25. The diagram below shows the pathway of a ball from point X to point Y.

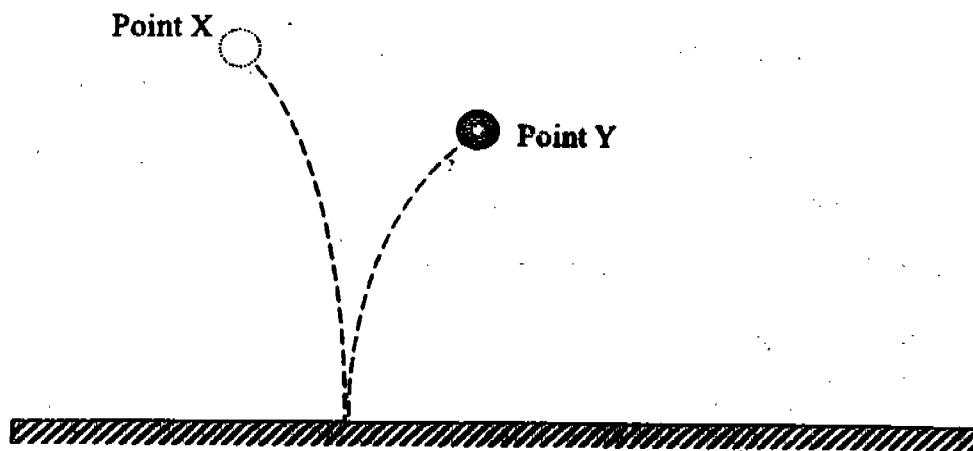

Which one of the graphs correctly shows the amount of kinetic energy and gravitational potential energy of the ball from point X to point Y?

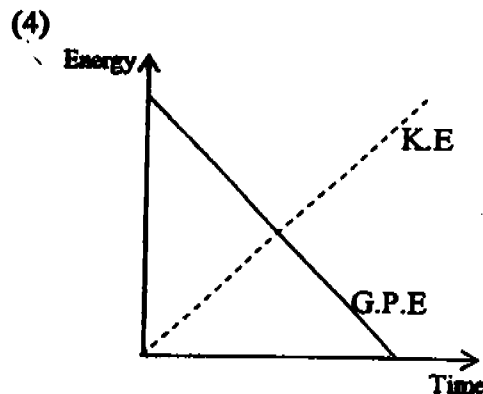
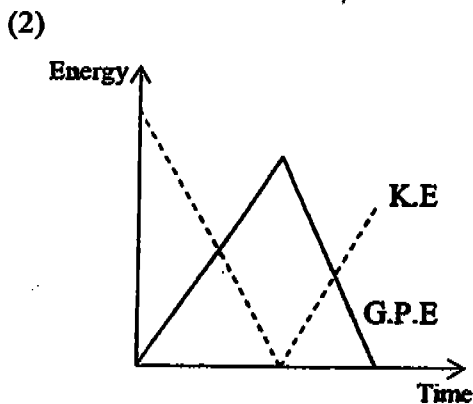
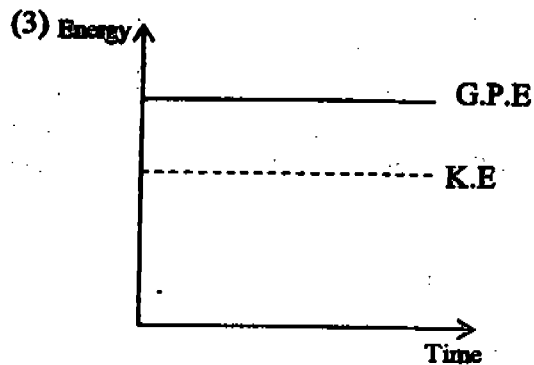
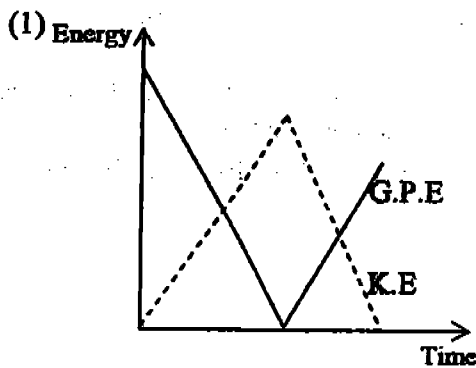

—	Gravitational Potential Energy (G.P.E)
- - -	Kinetic Energy (K.E)

26. Joy noticed that when she pressed the 'on/off' switch of an electric kettle, a small red bulb lighted up and the water started to get warmer. Choose the correct energy conversion when the electrical kettle is being switched on.

- (1) Chemical Potential Energy → Kinetic Energy → Electrical Energy → Light + Heat + Sound Energy
- (2) Chemical Potential Energy → Kinetic Energy → Electrical + Sound Energy → Light + Heat Energy
- (3) Electrical Energy → Sound Energy → Light + Heat Energy
- (4) Electrical Energy → Light + Heat + Sound Energy

27. Study the energy conversion below.

Chemical Potential Energy → Kinetic Energy → Sound + Heat Energy

Which of the following action/s show/s the same energy conversion?

- A Clapping of hands
- B Winding up a toy car
- C Switching on a torch light
- D Using a hammer to hit a piece of rock

- (1) A only
- (2) B only
- (3) A and D only
- (4) C and D only

28. Study the Venn diagram below carefully.

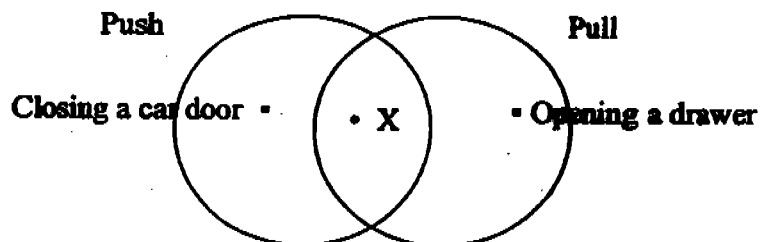

Which one of the following activities is X most likely to be?

- (1) Kneading dough
- (2) Stretching a rubber band
- (3) Hammering a nail into the wall
- (4) Typing on a computer keyboard

29. The diagrams show a block of wood resting on a glass surface. Two equal forces (F) are acting on the wood. In which diagram will the wood definitely move?

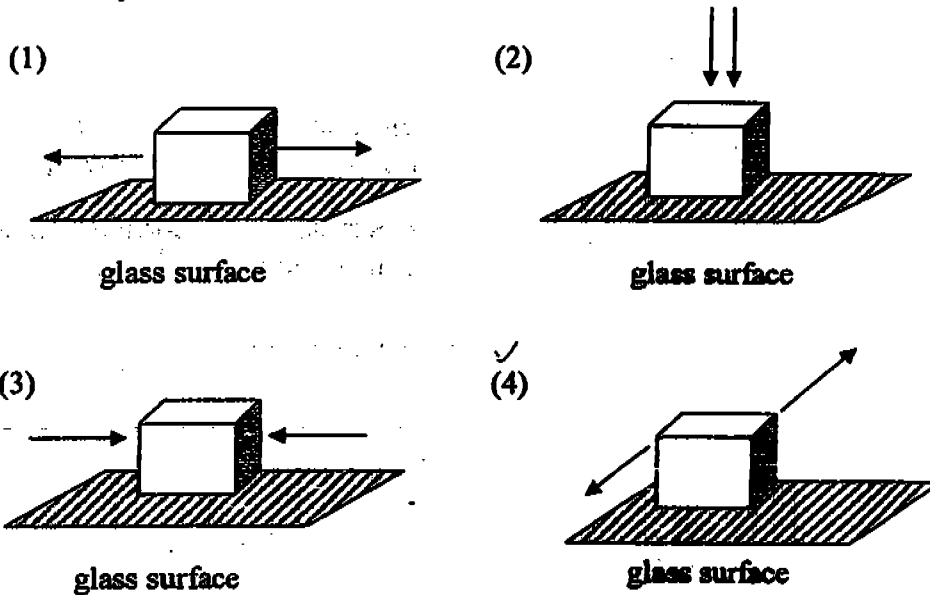

30. Susan placed 4 nails of the same length on a piece of softwood as shown below.

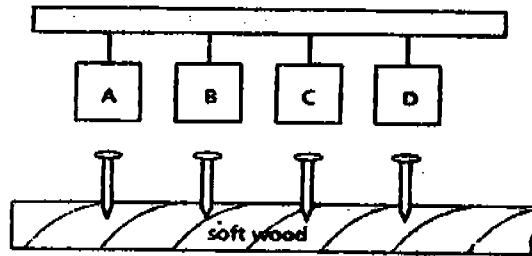

She dropped 4 weights A, B, C and D made from different materials onto each of the nails which were of the same height. The lengths of the 4 nails that went into the wood were measured and recorded in the table below.

Weights	Length of nail that went into the wood (cm)
A	2.2
B	1.7
C	0.8
D	1.1

Based on the results of the experiment, choose the statement that shows the correct inference?

- (1) Weight C is the heaviest.
- (2) Weight A is the lightest.
- (3) Weight B is lighter than Weight D.
- (4) Weight A is heavier than Weight B.



**CATHOLIC HIGH SCHOOL
PRIMARY SIX
MID YEAR EXAMINATION, 2005**

**SCIENCE
EM 1 / EM 2**

Name: _____ (2)

Class : Primary 6 _____

Date : 19 May 2005

BOOKLET B

16 Questions
40 Marks

Total Time for Booklets A & B : 1 hour 45 minutes

Instructions to Candidates

Follow all instructions carefully.
Answer all questions.

Score	
Section A	60
Section B	40
Total	100

Parent's Signature: _____

Date: _____

Section B: Open-Ended Questions (40 marks)

Read the following questions carefully and write your answers in the space provided. The maximum marks that can be awarded is shown at the end of each question or part-question.

31. The diagram below shows the cross-section of a flower.

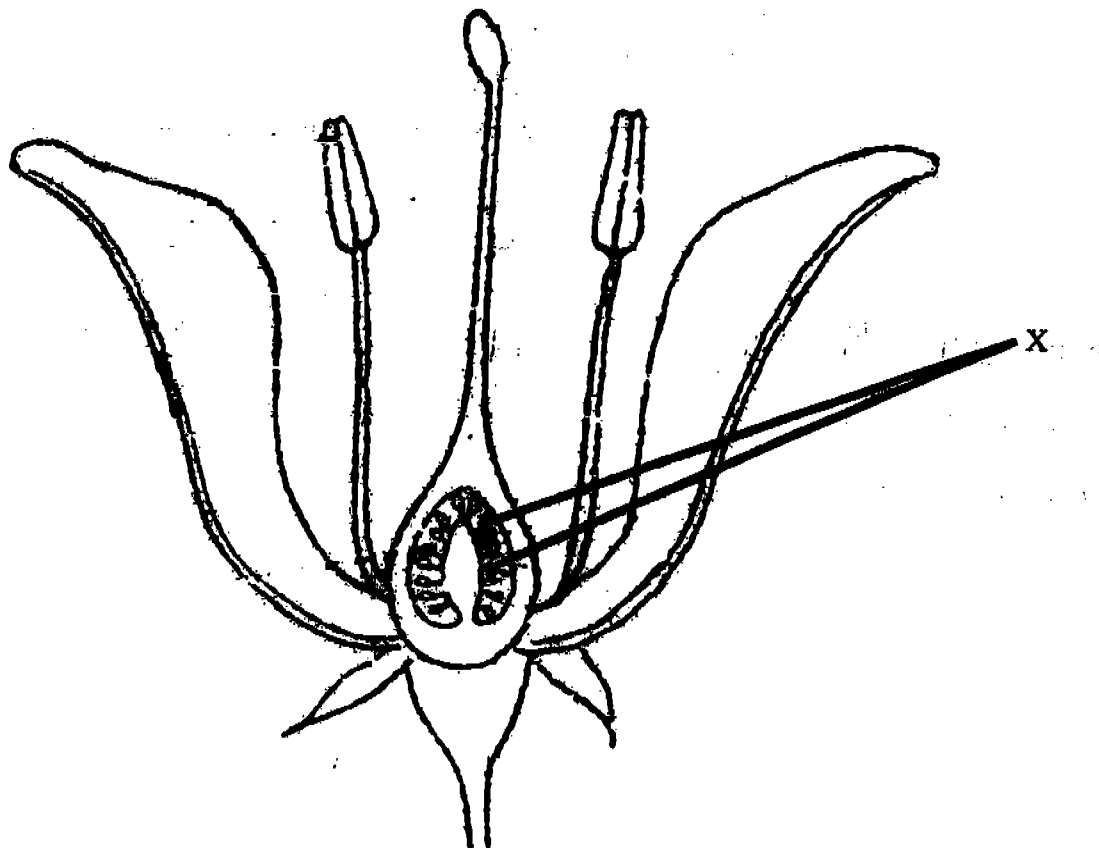

- (a) On the diagram, label (i) the stigma using the letter A, and (ii) the anther using the letter B. [1]
- (b) What will the parts labelled X develop into? [1]

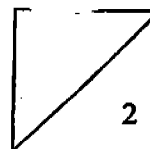

32. The picture below shows an arm of a man. To pull the lower bone up, the biceps muscle contracts and the triceps muscle relaxes. To pull the lower bone down, the biceps muscle relaxes and the triceps muscle contracts.

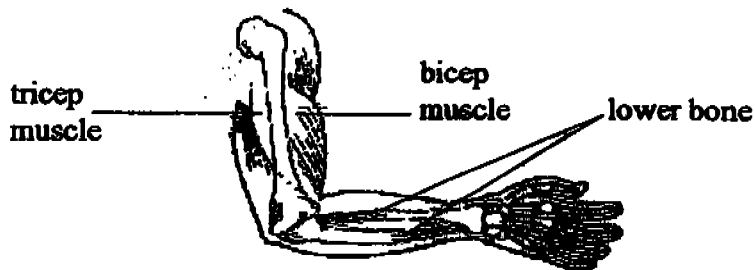

- (a) Which muscle has to work harder during both activities? [1]

- (b) Explain your answer in (a). [1]

33. 2 beakers X and Y of the same size were filled with the same volume of water was set up as shown below. For both beakers, a layer of oil has been poured into it.

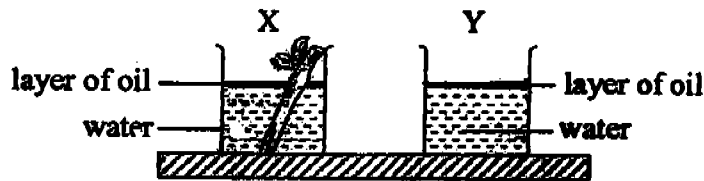

- (a) What is the layer of oil for? [1]

- (b) What is the purpose of beaker Y in the above experiment? [1]

34. The diagram below shows how blood travels in our body.

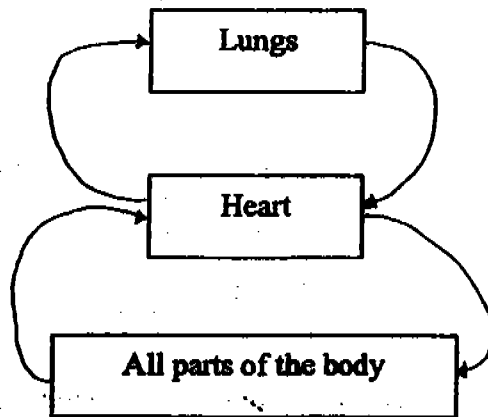

- (a) Indicate the movement of blood in our body using arrowheads (\rightarrow). [1]
- (b) State one similarity between the circulatory system of a human and a fish. [1]

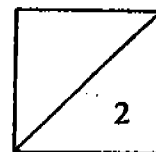

35. Aziz collected 4 fruits from a plant that disperses by splitting. He subjected the 4 fruits to different temperatures. The results are as follows:

	Fruit A	Fruit B	Fruit C	Fruit D
Temperature	35°C	30°C	20°C	5°C
Time taken to split the fruit	Splits after 2 hours	Splits after 3 hours	Splits after 12 hours	Nothing happens
Distance the seeds scattered	1½m	1½m	¾m	0m

- a) What was Aziz trying to find out? [1]

- b) Draw a line graph below to show the relationship between the temperature and the distance the seeds scattered. [1]

- ii) Label the axes of the graph.]

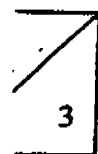
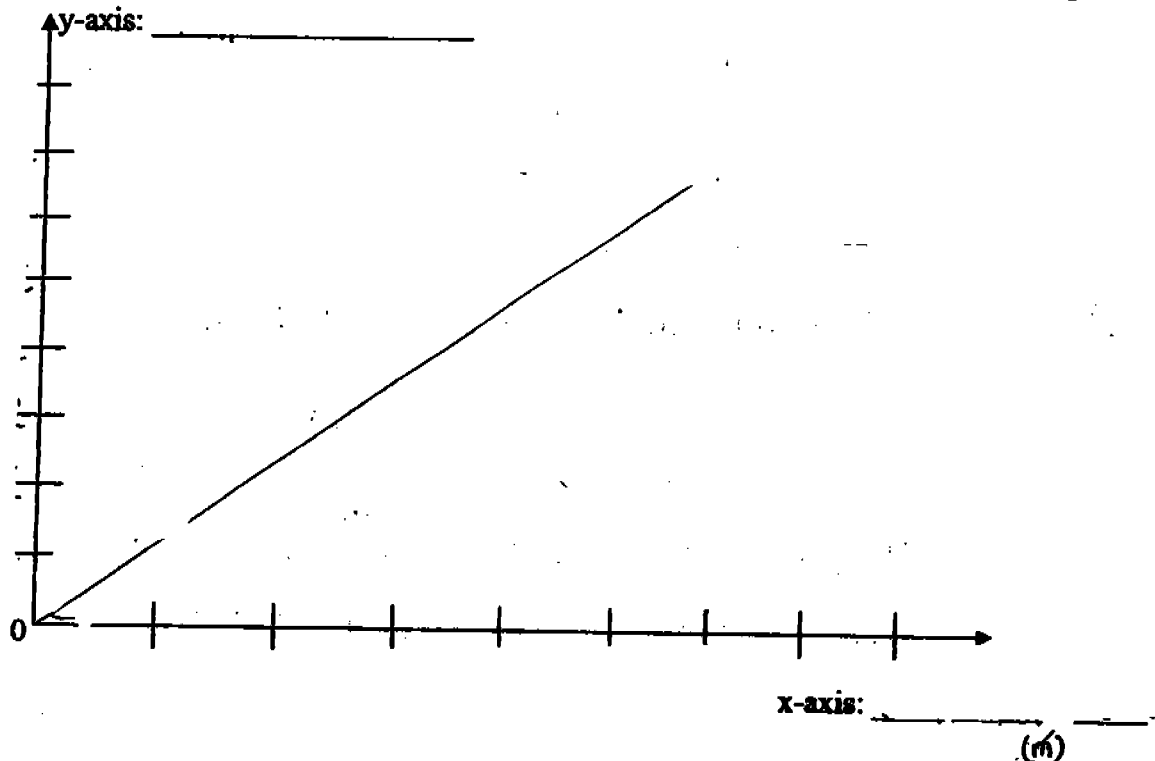

36. The following organisms are grouped according to their main differences.

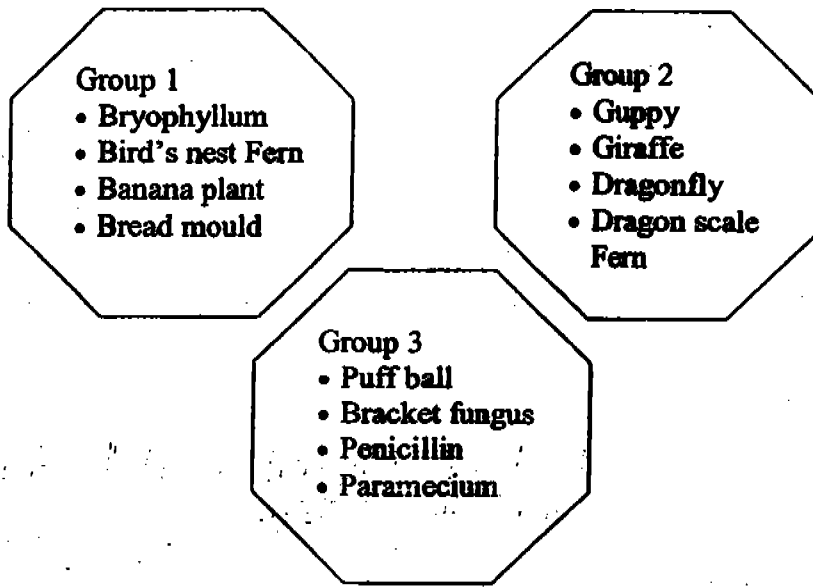

(a) In each group, there is one organism that is wrongly classified. Name the ~~animal~~ ^{organism} for each group. [1]

Group 1: _____

Group 2: _____

Group 3: _____

(b) State the main similarity between the organisms in groups 1 and 3. [1]

(c) State the main difference between the organisms in groups 1 and 3. [1]

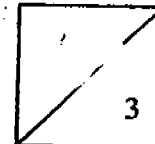

37. Fill the blanks with an appropriate word each. [3]

The survival of an organism is affected by the (a) _____ characteristics of the environment, the (b) _____ of food and the presence of other organisms. This may be in the form of (c) _____ which will hunt them down, another organism competing for the same kind of food or micro-organisms like (d) _____ which cause diseases. When the conditions of the environment become (e) _____, the organisms will either die, move away from those surroundings or (f) _____ to the new conditions.

38. The diagram below shows a food web. [3]

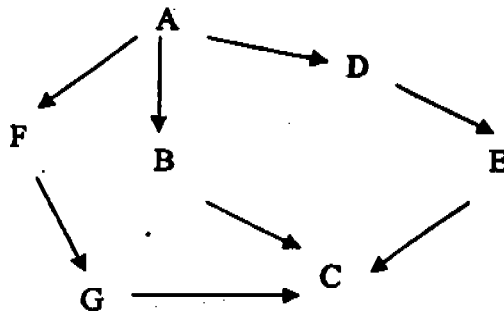

Put a tick (✓) in the correct boxes to show whether the statements given are 'True', 'False' or 'Not Possible to Tell'.

		True	False	Not Possible to Tell
a)	Organism A is a mango tree.			
b)	Organism E is both a predator and prey.			
c)	Organism G is an omnivore.			
d)	Organism C has a head, body and leg.			
e)	Organism A gets its food from 3 other organisms.			
f)	If the population of organism D decreases, the population of organism C will decrease.			

39. Jeremy wanted to separate the contents of a beaker which was filled with water, sand and iron filings. He was given only a magnet, a filter paper, a funnel and a measuring cylinder. He could not put the magnet into the beaker. List down the 3 steps he should take to conduct a fair test to separate the contents.

Step 1: _____

Step 2: _____

Step 3: _____

40. Jane carried out an experiment in a darkened room as shown in the diagram below. She placed 3 different materials A, B and C in a straight line. When the torch was switched on, a clear circular patch of light was seen on Material C.

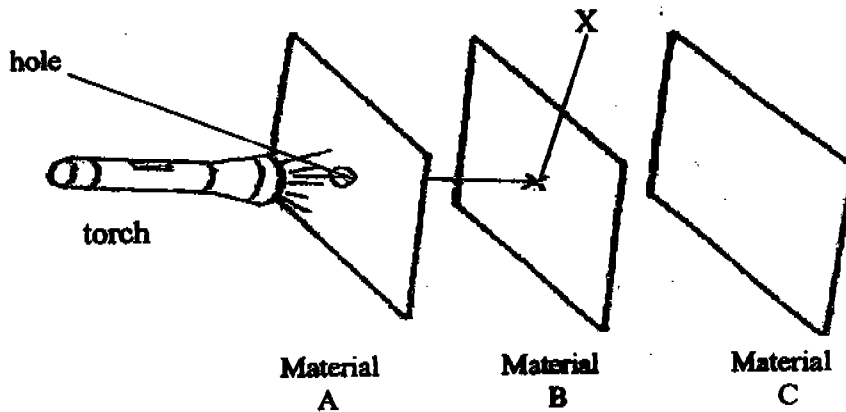

- (a) Give a reason to explain why light is able to pass through Material B even though there is no hole at the position marked X? [1]
- _____
- _____
- (b) Give an example that Material B could be made of. [1]
- _____
- (c) What conclusion can Jane infer about Materials A and C from this experiment? [1]
- _____

41. The diagram below shows an electric circuit.

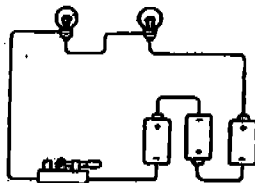

Draw a circuit diagram in the space provided to represent the above electric circuit. [2]

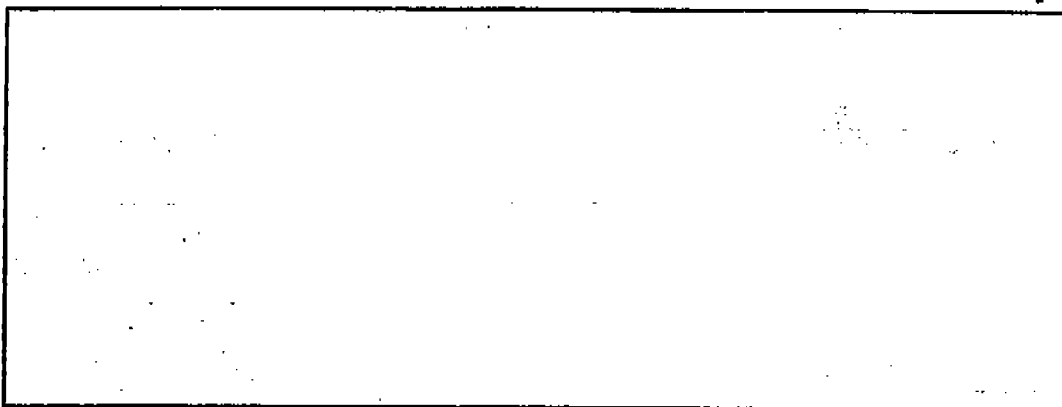

42. The diagram below shows a fixed pulley and an inclined plane.

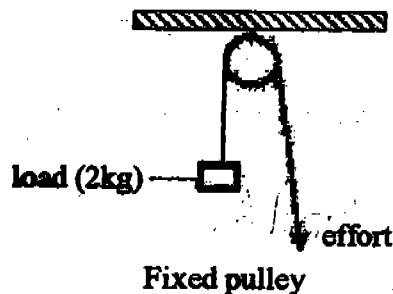
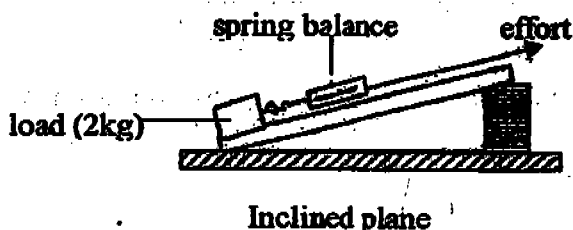

- (a) Which one of the simple machines above is a lever system? [½]

- (b) Ah Ming found that he needed an effort of 1.2 kg and 2.5 kg to lift up the load using the two different simple machines shown above.

- (i) Which one of the above simple machines is more likely to require him to use an effort of 2.5 kg? [½]

- (ii) Explain your answer in (i). [1]

43. May wants to find out which material can keep ice cubes from melting for the longest period of time. She then conducted an experiment using the set up shown below.

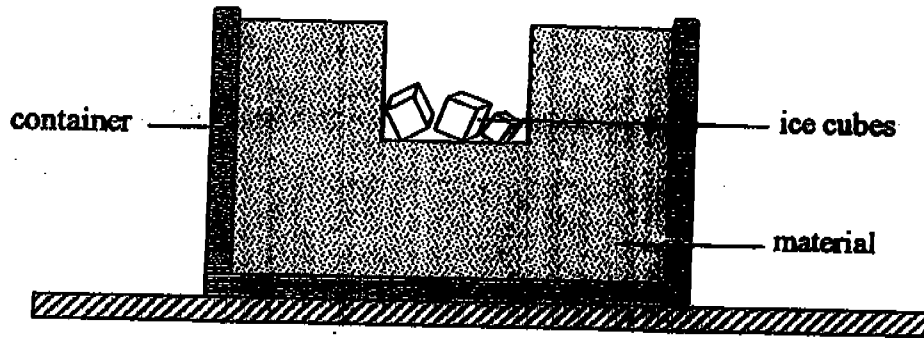

Different materials A, B, C and D were each placed into the container at different times and the time taken for the similar sized ice block to melt was recorded as shown below.

Material	Time taken to melt the ice
A	2 h 25 min
B	1h 45 min
C	45 min
D	1h 10 min

- (a) Arrange the materials from the worst conductor of heat to the best conductor of heat.
-
- (b) If you want to keep a block of ice overnight, which one of these materials would you use? [1]
-
- (c) Identify one variable that must remain unchanged for this experiment. [1]
-

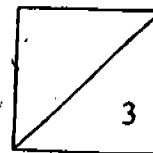

44. Zhi Rong dropped 4 balls of the same size but of different masses into 4 trays of fine sand. The balls were dropped from different heights H1, H2 and H3 as shown in the diagram below.

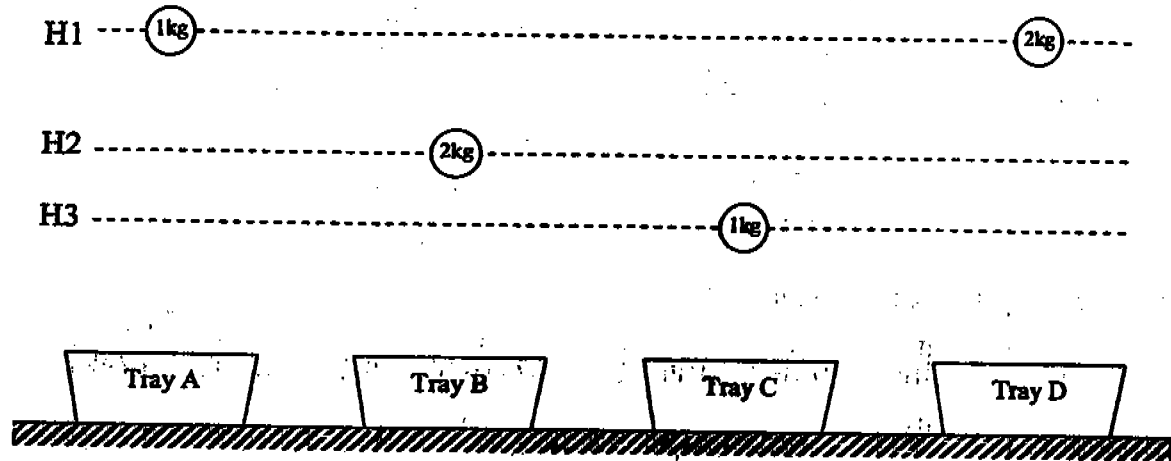

- (a) Arrange in ascending order the depths of the depressions or craters formed in the trays when the balls are dropped. Use the letters A, B, C and D in your answer.

- (b) What does this tell you about the gravitational potential energy of an object? [1]

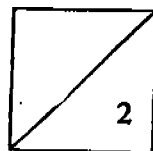

45. Study the diagrams below carefully.

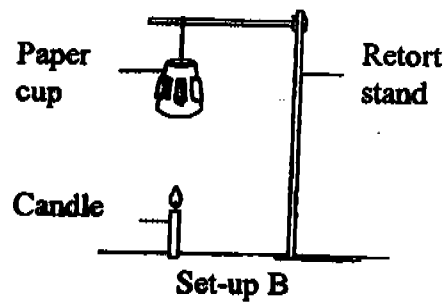
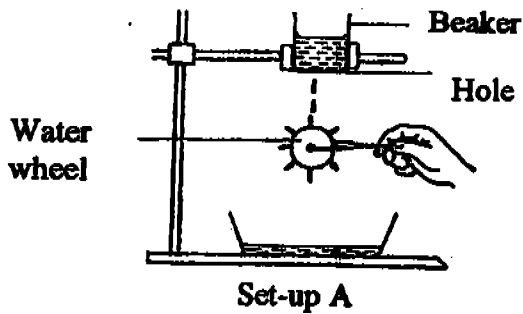

(a) State your observation in each set-up. [1]

Set-up A: _____

Set-up B: _____

(b) State the difference in the energy source in the two set-ups that brought about the changes in question (a). [1]

46. The picture below shows Ali pulling a 50 kg load up a slope.

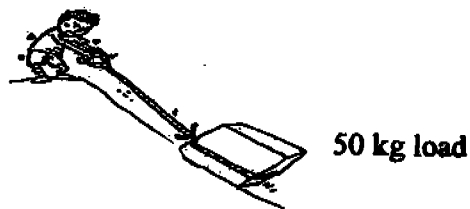

(a) Apart from the pulling force, what are the other 2 types of forces acting on the 50kg load? [1]

(b) For Ali to pull the 50kg load up the slope, does he need to exert a greater, equal or lesser amount of force? [1]

(c) Suggest how you can pull the load using a force that is less than 50 Kg. [1]

58

SAT

CATHOLIC HIGH SCHOOL (PRIMARY)
MID YEAR EXAMINATION 2005
SCIENCE
PRIMARY SIX

01. 2	11. (3)	21. 2
02. 2	12. 3	22. 4
03. 3	13. 2	23. 3
04. 4	14. 4	24. 1
05. 4	15. 3	25. 1
06. 4	16. 3	26. 4
07. 2	17. 2	27. 3
08. 4	18. 1	28. 1
09. 2	19. (1)	29. (4)
10. 1	20. 1	30. 4

31) a)  b) seeds

32) a) Bicep muscle
b) The bicep work harder as it has to pull the lower bone up, therefore works against gravity.

33) a) To prevent evaporation of water.
b) To act as a comparison for beaker X and Y and to show that the decrease in water level is due to the plant taking in water.

34) a)  b) The heart of both the human and fish pump oxygen, digested food and water to all parts

35) a) He was trying to find out whether temperature affects the time taken to split the fruit and the distance the seeds are scattered.

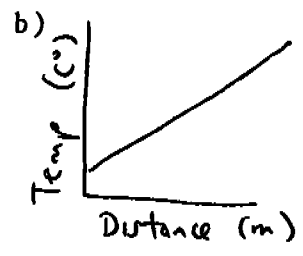

36) a) Group 1 : Bread mould
2 : Dragon scale fern
3 : Paramecium

b) Both reproduce

c) Group 1 can photosynthesize to make food

- 37) a) physical b) amount c) predator d) virus
 e) unfavourable f) adapt

38)

		✓
✓		
	✓	
		✓
	✓	
		✓

- 39) Place the magnet over the beaker to get the iron filings out.

Place the filter paper in the funnel and put the funnel on top of the measuring cylinder.

Pour the contents in the beaker into the funnel to separate the water with the sand.

- 40) a) Material B must be transparent.

b) Glass

c) Light cannot pass through materials A and C

41)

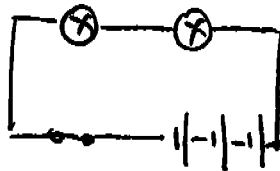

- 46) b) Air needs to exert a force greater than 50 kg.

c) Put wheels below the load

- 42) a) The fixed pulley.

b) i) The fixed pulley

ii) A fixed pulley requires a greater effort to overcome the load due to friction.

- 43) a) Material A, material B, material D, material C.

b) I would use material A

c) The number of ice cube.

- 44) a) Tray C, tray B, Tray A and tray D.

b) The GPE of an object depends on its height from the surface and its mass.

- 45) a) The water from the beaker will turn the water wheel.

The paper cup will start to spin.

b) A: The energy source is GPE and KE of water.

B: The energy source is KE of air brought about by the burning candle.