

NANYANG PRIMARY SCHOOL

PRIMARY 6 SCIENCE

**PRELIMINARY EXAMINATION
2006**

BOOKLET A

Date : 24 August 2006

Duration : 1 h 45 min

Name : _____ ()

Class: Primary 6 ()

Marks Scored:

Booklet A:		60
Booklet B :		40
Total :		100

Parent's signature:

**DO NOT OPEN THIS BOOKLET UNTIL YOU ARE TOLD TO DO SO.
FOLLOW ALL INSTRUCTIONS CAREFULLY.**

Booklet A consists of 20 printed pages including this cover page.

Section A (30 x 2 marks = 60 marks)

For each question from 1 to 30, four options are given. One of them is the correct answer. Make your choice (1, 2, 3 or 4). Shade the correct oval (1, 2, 3 or 4) on the Optical Answer Sheet provided.

1. Ravi posed the following riddle to his friends.
"I am the largest organ in your body. I weigh twice as heavy as your brain. Which organ am I?"

Which of the following organs is Ravi referring to?

- | | |
|-----------|-------------|
| (1) heart | (2) liver |
| (3) skin | (4) stomach |

2. Which one of the following pie charts correctly identifies the proportion of gases in the air that we breathe out?

(1)

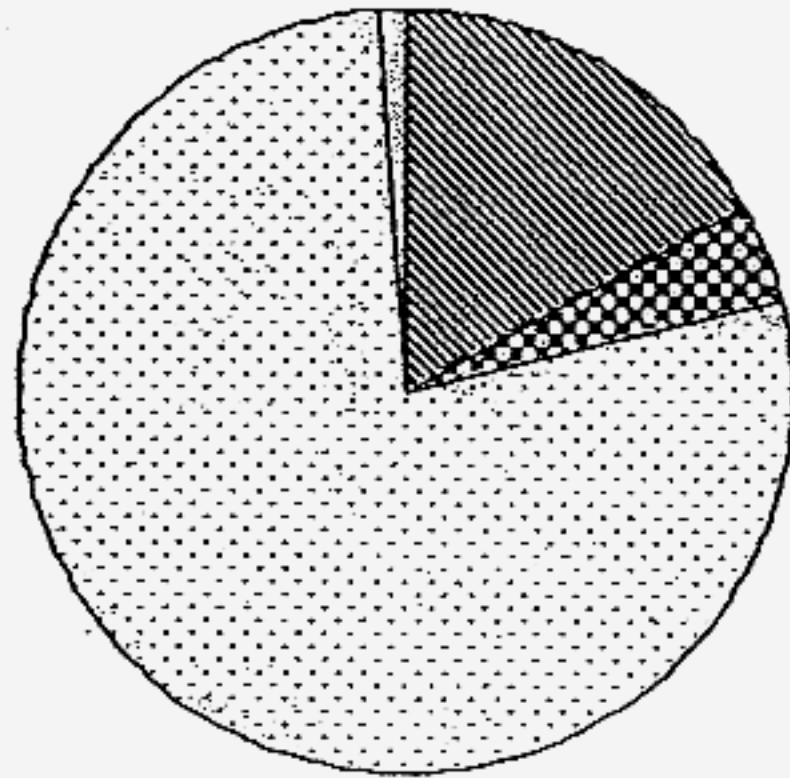

(2)

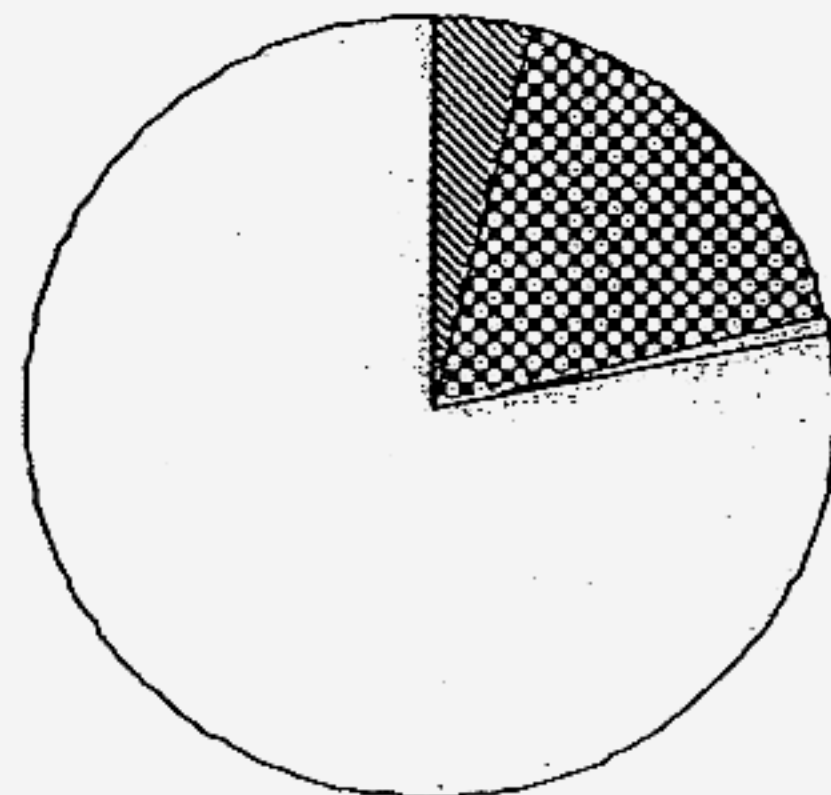

(3)

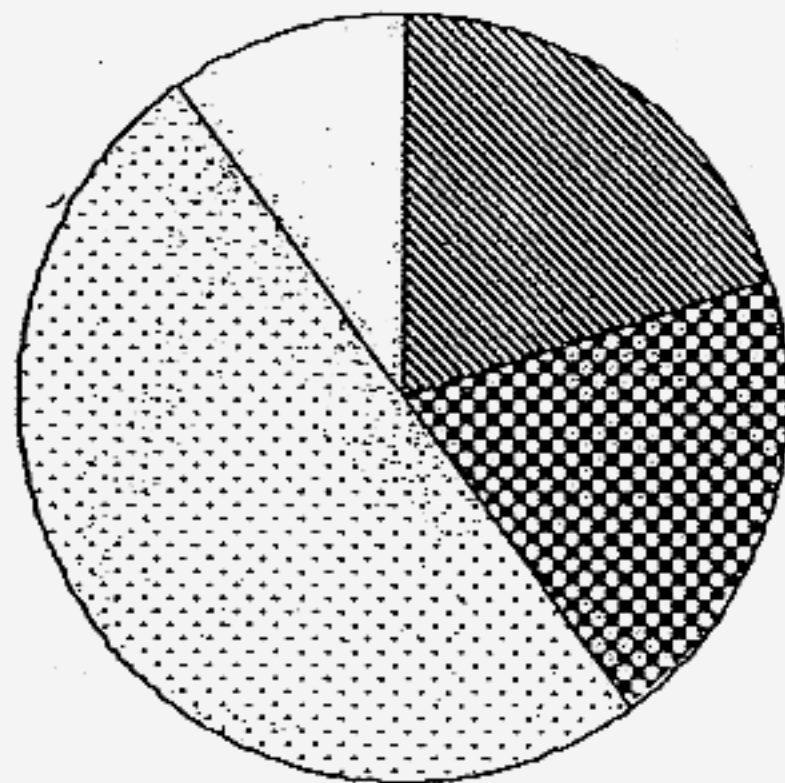

(4)

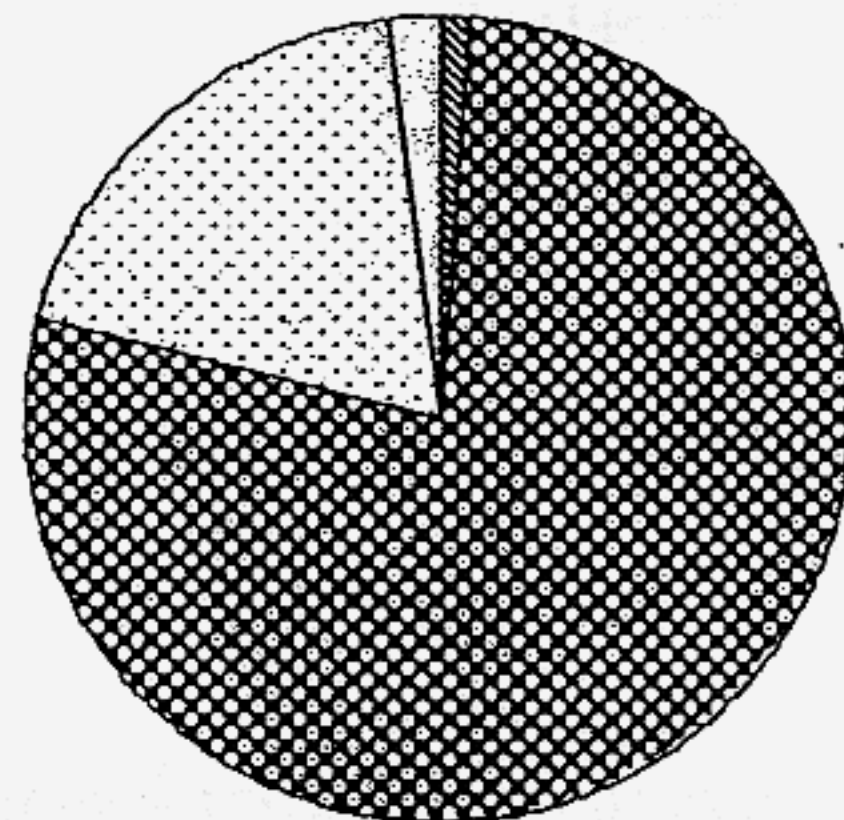

Key:

- | | |
|--|----------------|
| | Nitrogen |
| | Carbon dioxide |
| | Oxygen |
| | Other gases |

3. The different parts of the digestive system labelled as A to E, are as shown below.

A – small intestine
 B – gullet
 C – anus
 D – stomach
 E – large intestine

Which one of the following options correctly identifies the path that food takes after it is swallowed?

- (1) B → D → A → E → C
 (2) B → A → E → D → C
 (3) D → B → A → E → C
 (4) D → B → E → A → C

4. Study the life cycle of the maize plant given below.

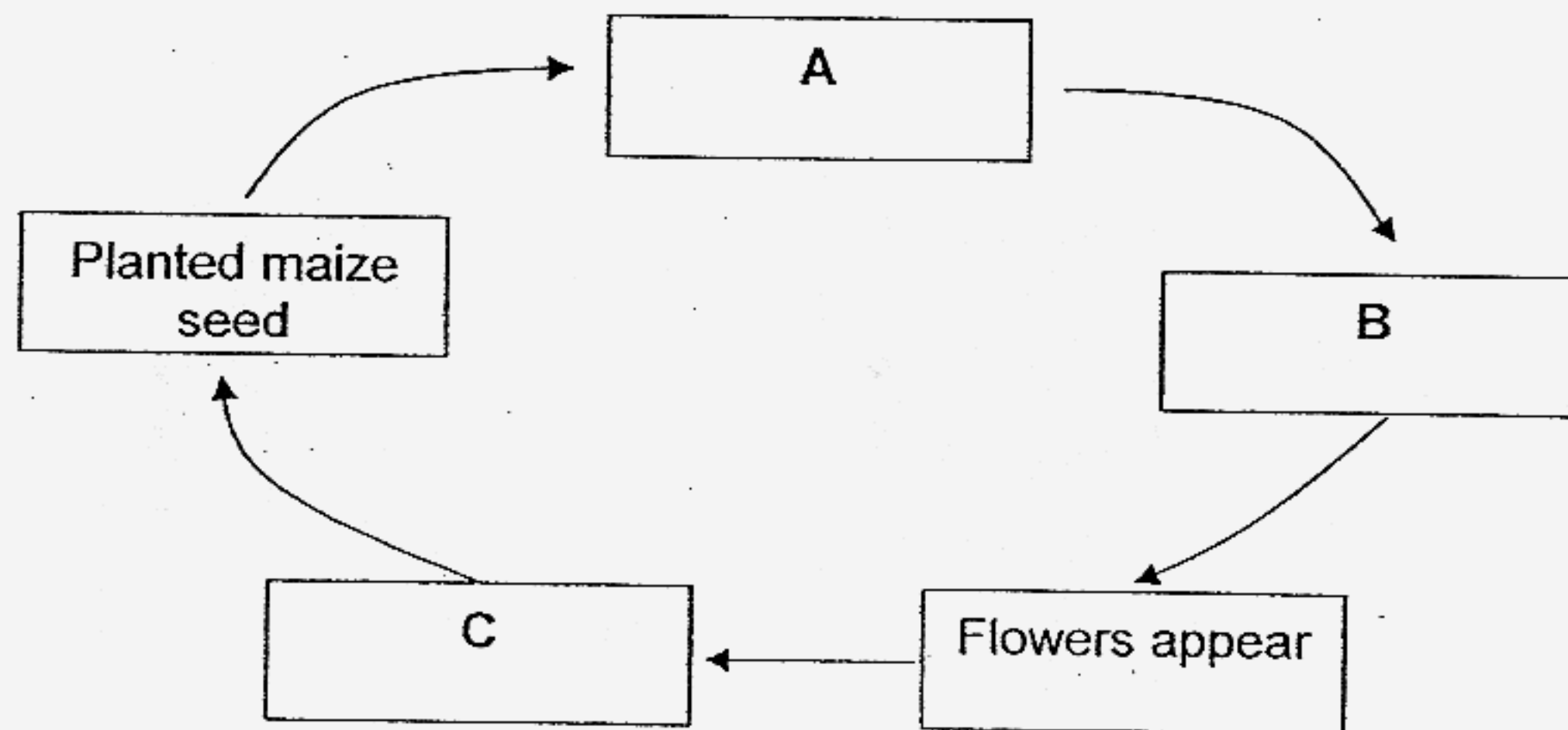

Which one of the following groups correctly identifies A, B and C?

	A	B	C
(1)	Seed is given warmth, air and water	Fruit grows bigger	Maize cob with many fruits
(2)	Young plant appears	First leaves appear	Maize cob with many fruits
(3)	Young plant appears	Fruit grows bigger	Fruit ripens and explodes
(4)	Seed is given warmth, air and water	Fruit ripens and explodes	First leaves appear

5. Shu Yen wants to conduct an experiment to find out how light affects the rate of growth for a plant. Of the four set-ups A, B, C and D shown below, which two should she use to ensure a fair test?

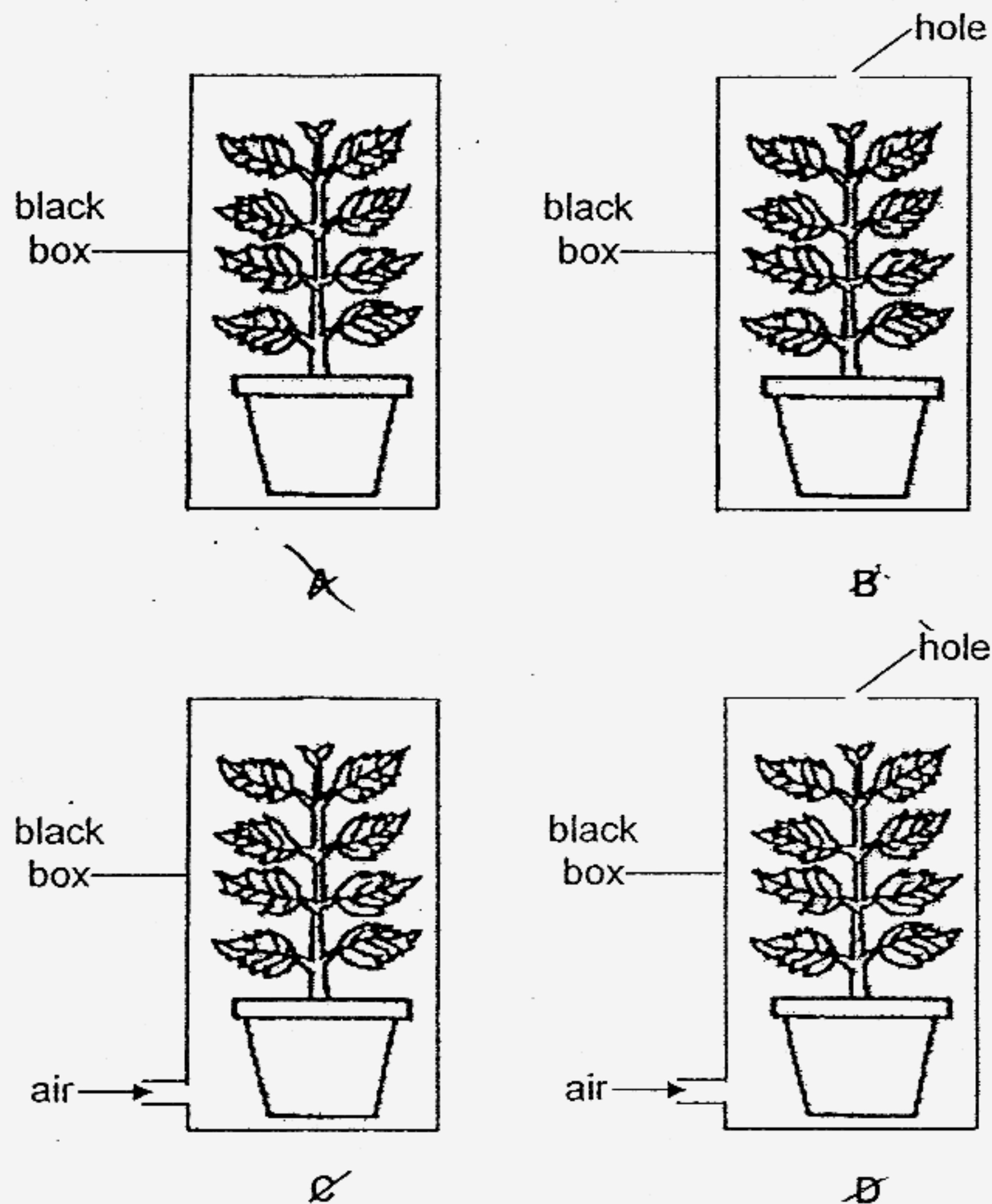

- (1) A and B
(3) B and D

- (2) A and C
(4) C and D

6. Study the diagram below.

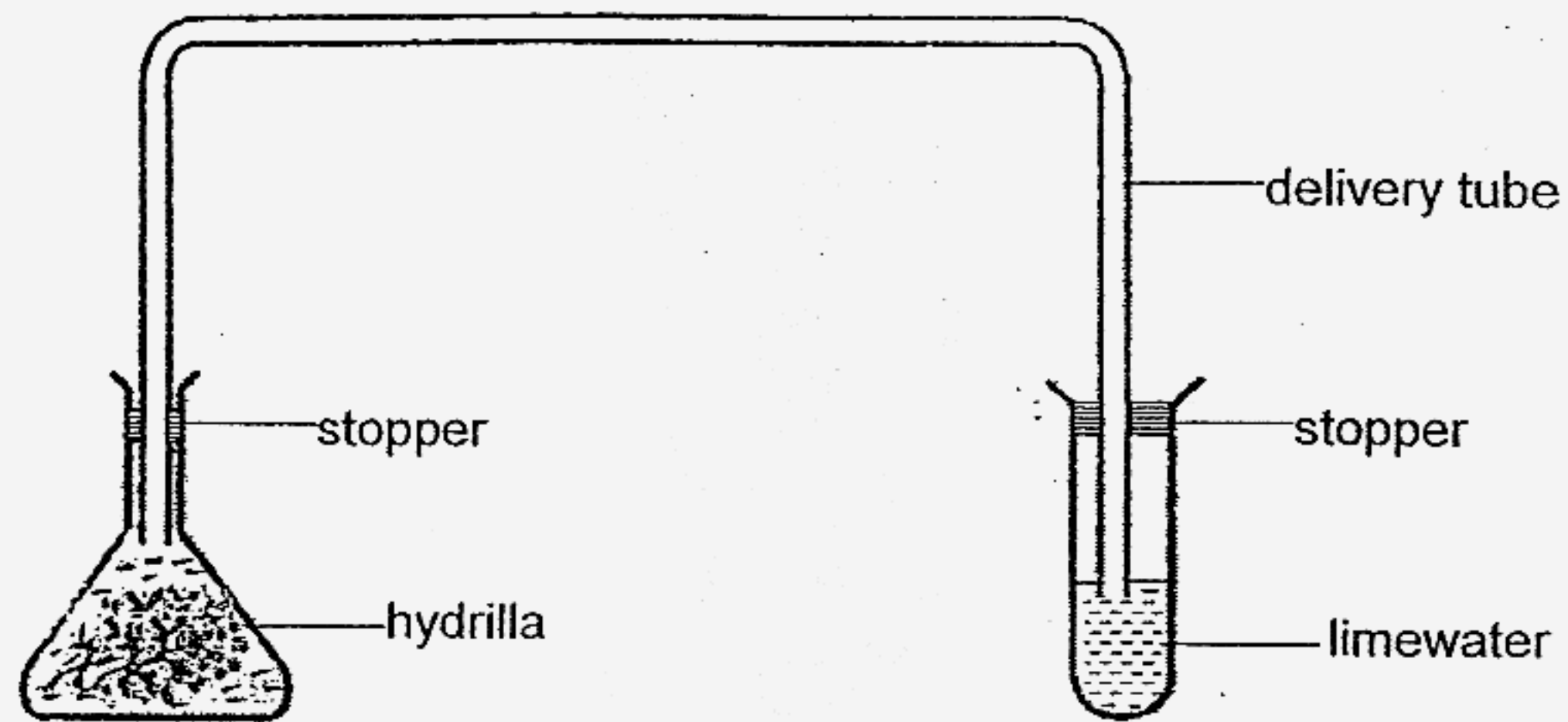

The set-up above was placed in a garden. After a while, bubbles were observed in the limewater. How would these bubbles affect the limewater?

- (1) The limewater will evaporate.
 - (2) The limewater will turn chalky.
 - (3) The limewater will remain colourless.
 - (4) The limewater will move up the delivery tube.
7. Study the classification table given below.

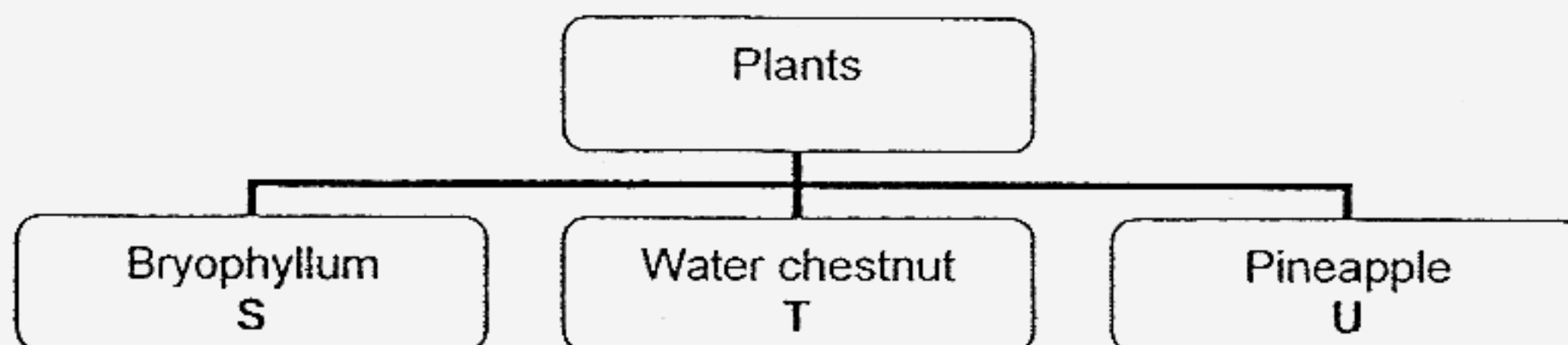

Which one of the following groups correctly represents S, T and U?

	S	T	U
(1)	begonia	potato	strawberry
(2)	sansevieria	ginger	tapioca
(3)	african violet	onion	banana
(4)	allamanda	sweet potato	heliconia

8. The diagram below shows a picture of a cattail taken from a pond.

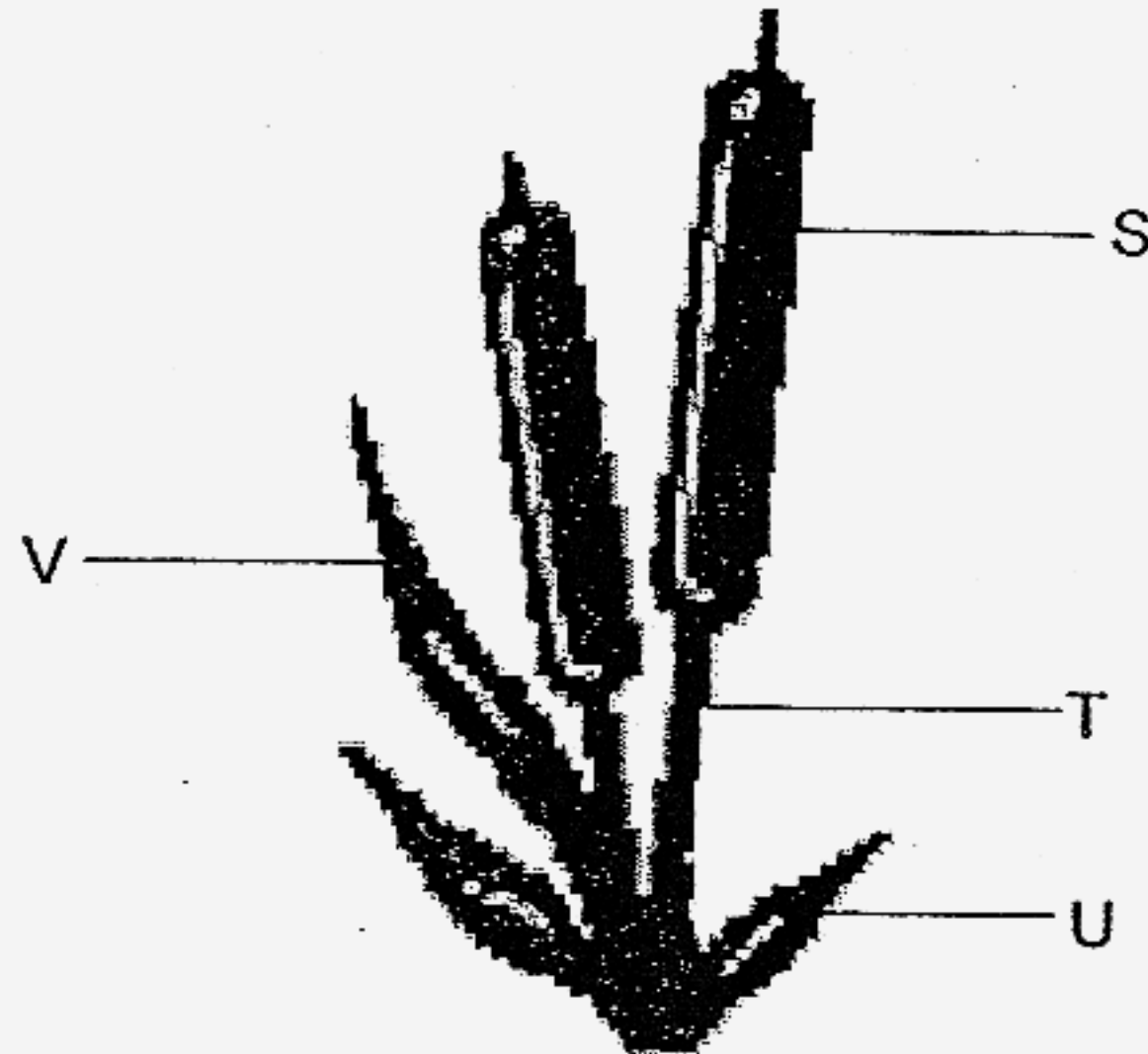

Which of the following statements correctly describe the function of each of the labelled parts?

- ☒ A Part V helps to form sugar by trapping light.
- ☐ B Part U helps to take in nutrients from the soil.
- ☒ C Part S helps to contain the seeds when the plant matures.
- ☒ D Part T helps to support and raise part S out of the water.

- (1) A, B and C only
- (3) B, C and D only

- (2) A, C and D only
- (4) A, B, C and D

9. A terrarium was set up and used for keeping and raising several animals and plants for observation. The terrarium was then placed in a dark room for several weeks. Four pupils made statements of hypotheses at the start of the experiment.

Aini: The terrarium will keep all the animals alive as it is self-sustaining.

Bala: The terrarium will keep all the animals alive as there are plants to provide food for all the animals.

Cailli: The terrarium will not keep all the animals alive as not all the animals are plant-eaters.

David: The terrarium will not keep all the animals alive as there is no sunlight to enable the plants to make food.

Which pupil's hypothesis could be proven correct at the end of the experiment?

(1) Aini

(2) Bala

(3) Cailli

(4) David

10. Zaki discovered a fruit during his hiking trip. He had never seen the fruit before and he described it to his friends as follows:

'It is light and small. It has stiff hairs sticking out of it.
The plant it came from is very short.'

Which of the following sets of fruits is dispersed in the same way as that found by Zaki?

(1) angsana and shorea

(2) lalang and rambutan

(3) mimosa and lovegrass

(4) african tulip and mimosa

11. The table below gives the characteristics of 3 groups of aquatic plants.

A	B	C
<ul style="list-style-type: none"> ● weak stem ● roots grow into the soil ● thin leaves 	<ul style="list-style-type: none"> ● hard and sturdy stem ● more stomata on the upper leaf surface ● leaves covered with a waxy or hairy layer 	<ul style="list-style-type: none"> ● air spaces in the stem ● more stomata on the upper leaf surface ● leaves covered with a waxy or hairy layer

Based on the information given above, which one of the following correctly identifies A, B and C?

	A	B	C
(1)	floating plant	submerged plant	partially submerged plant
(2)	submerged plant	partially submerged plant	floating plant
(3)	floating plant	partially submerged plant	submerged plant
(4)	partially submerged plant	floating plant	submerged plant

12. Suria conducted four experiments on food relationships in a community that consisted of a population of plant and three populations of organisms, X, Y and Z. She set up each of her experiments and tabulated her results based on the number of living organisms present at the end of the experiment.

Experiment	Organisms placed together	Size of the population	
		Start of the experiment	End of the experiment
A	Plants	large	decrease
	X	large	remains the same
	Y	large	remains the same
B	Plants	large	decrease
	Y	large	decrease
	Z	large	remains the same
C	Plants	large	decrease
	X	large	decrease
	Z	large	remains the same
D	Plants	large	remains the same
	Z	large	decrease

If she had observed dead organisms Z only in experiment D, which one of the following shows a possible food relationship among the plant and organisms X, Y and Z?

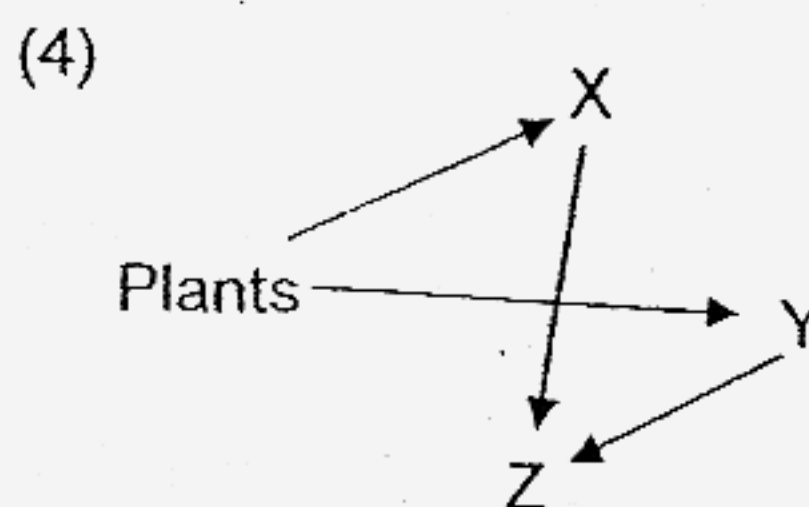
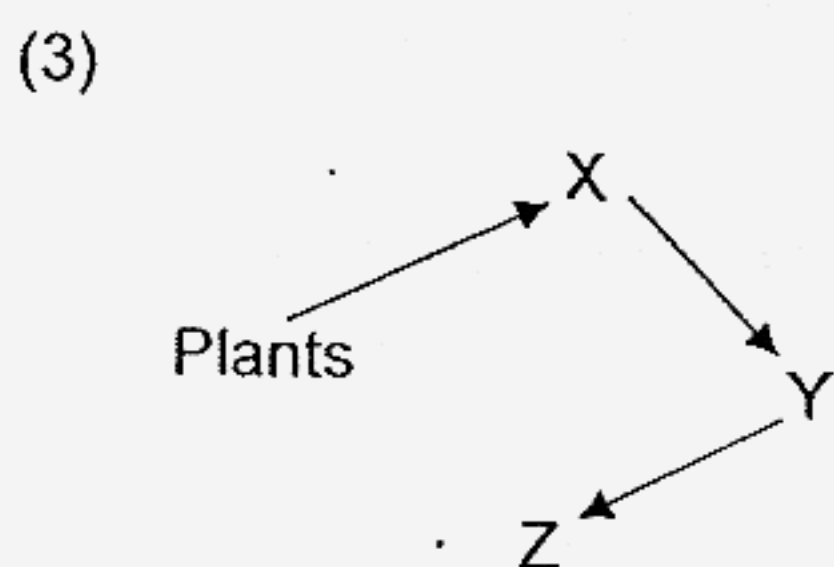
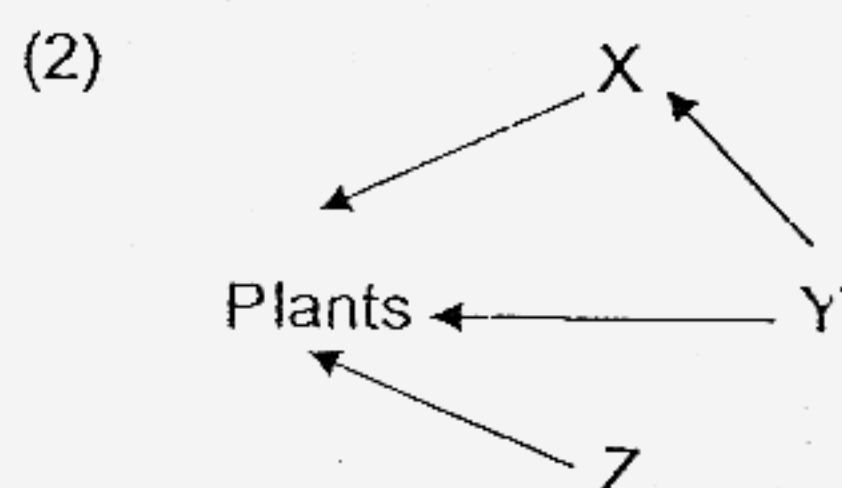
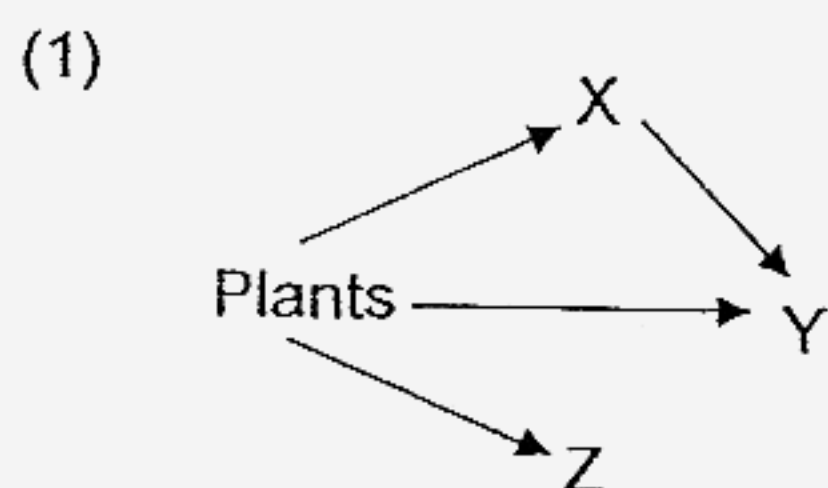

13. Which of the following statements describe the life cycles of a frog and a dragonfly?

- ~~A~~ They have a 3-stage life cycle.
~~B~~ The adults care for their young.
~~C~~ Their young breathe through gills.

- (1) A and B only
 (2) A and C only
 (3) B and C only
 (4) A, B and C

14. Study the classification table below.

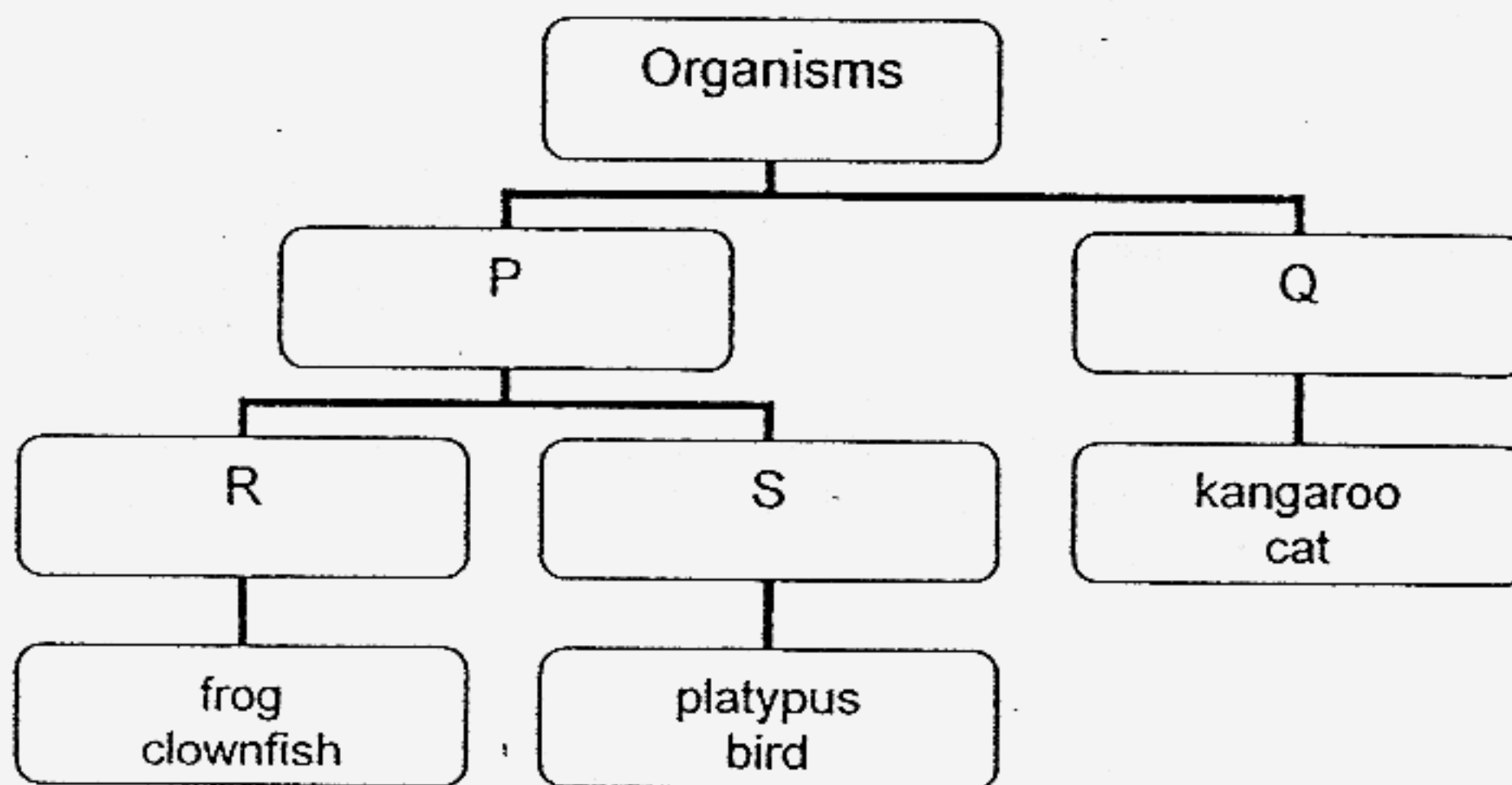

Which one of the following best represent R and S?

	R	S
(X)	Aquatic	Land
(X)	Non-mammals	Mammals
(X)	Lay eggs	Gives birth to its young
(4)	External fertilisation	Internal fertilisation

15. Which of the following activities have a negative impact on the environment?

- ~~A~~ Burning of fossil fuels
~~B~~ Burning trees in the forest.
~~C~~ Farming using weedkillers.
~~D~~ Increasing the use of chlorofluorocarbons (CFC).

- ~~(X)~~ A, B and C only
~~(X)~~ A, C and D only
 (3) B, C and D only
 (4) A, B, C and D

16. On the planet Venox, some astronauts carried out the following observations on several different things that they discovered there.

- A. Movement on their own
- ~~B.~~ Their number over time.
- C. Their interaction with their environment.

Which observation(s) is/are required to draw the conclusion(s) whether the things are living or non-living ?

- (1) B only
- (2) A and B only
- (3) A and C only
- (4) A, B and C

17. Study the flow chart below.

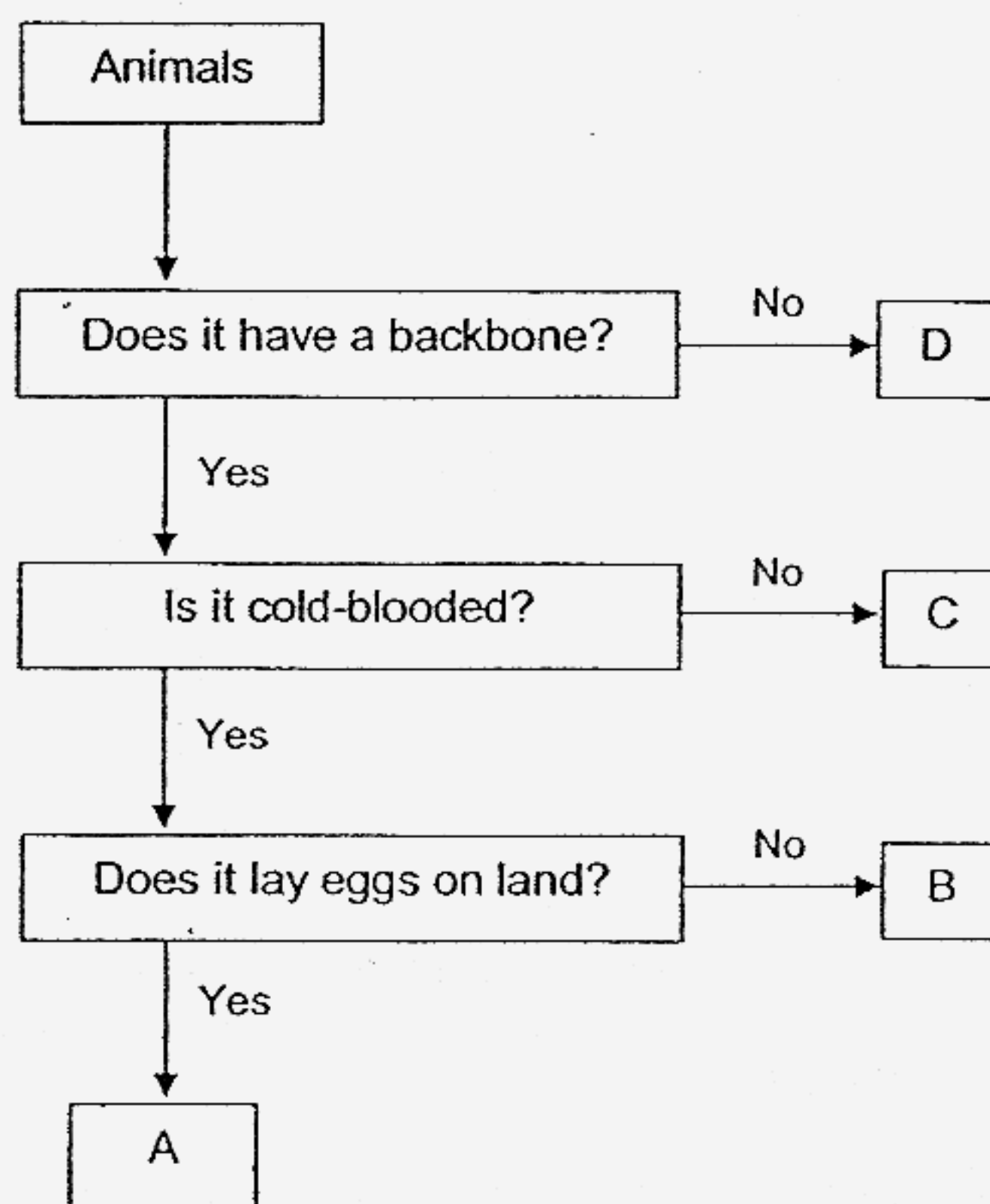

Which one of the following animals are A, B, C and D most likely to be ?

	A	B	C	D
(1)	Lizard	Toad	Parrot	Tortoise
(2)	Turtle	Earthworm	Goldfish	Snake
(3)	Crocodile	Frog	Duck	Snail
(4)	Millipede	Guppy	Dog	Spider

18. Which one of the following statements about micro-organisms is false?
- (1) All micro-organisms are food producers.
 - (2) Not all micro-organisms are single-cell organisms.
 - (3) Some micro-organisms can move about on their own.
 - (4) The sperm of a frog is not a micro-organism although it can only be seen under a microscope.

Use the classification below to answer questions 19 and 20.

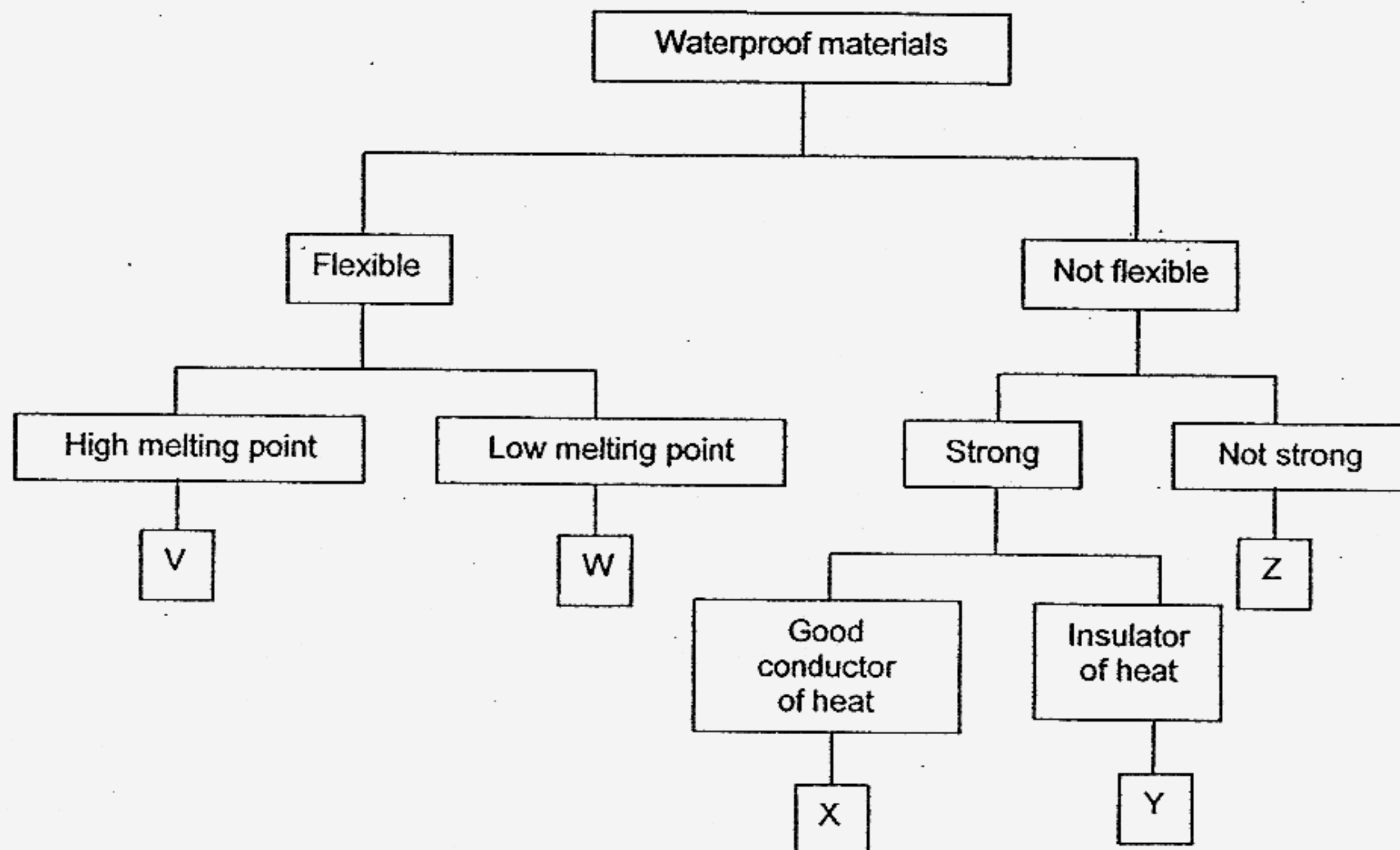

Susan was told to select the best materials for making boots and helmet for firemen. She was also told that the same material could not be used to make both items.

19. Which is the best material for making the boots?
- (1) V
 - (2) X
 - (3) Y
 - (4) Z
20. Which is the best material for making the helmet?
- (1) V
 - (2) W
 - (3) X
 - (4) Y

21. The table below shows the melting and boiling points of substances P, Q and R.

Substance	Melting point ($^{\circ}\text{C}$)	Boiling point ($^{\circ}\text{C}$)
P	42	78
Q	28	63
R	54	90

At which one of the following temperatures are the three substances in the same state?

- (1) 30°C (2) 49°C
 (3) 60°C (4) 80°C

22. Study the diagram below.

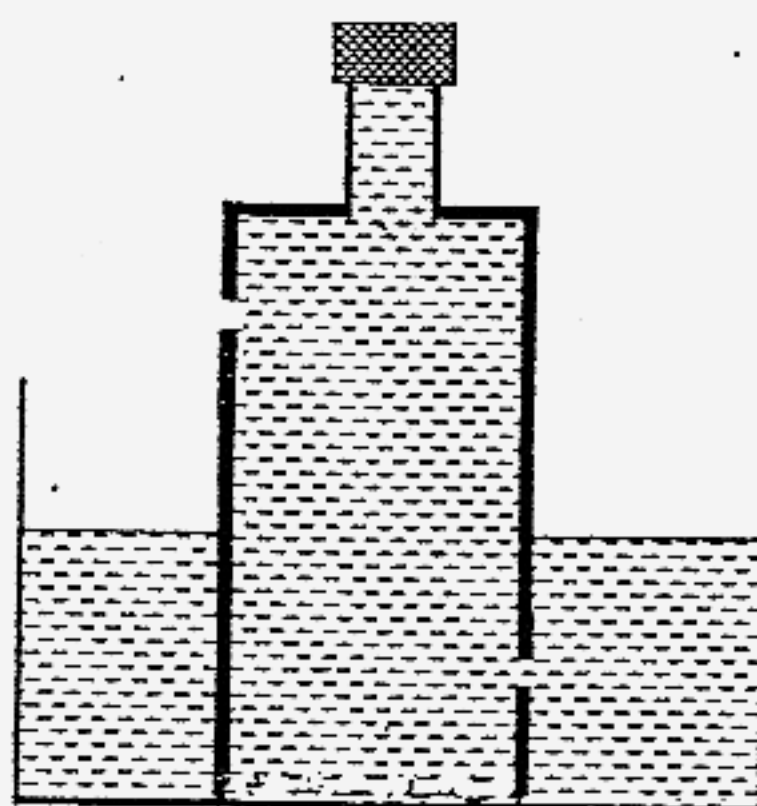

Which one of the following diagrams correctly shows what would happen when the bottle cap is removed?

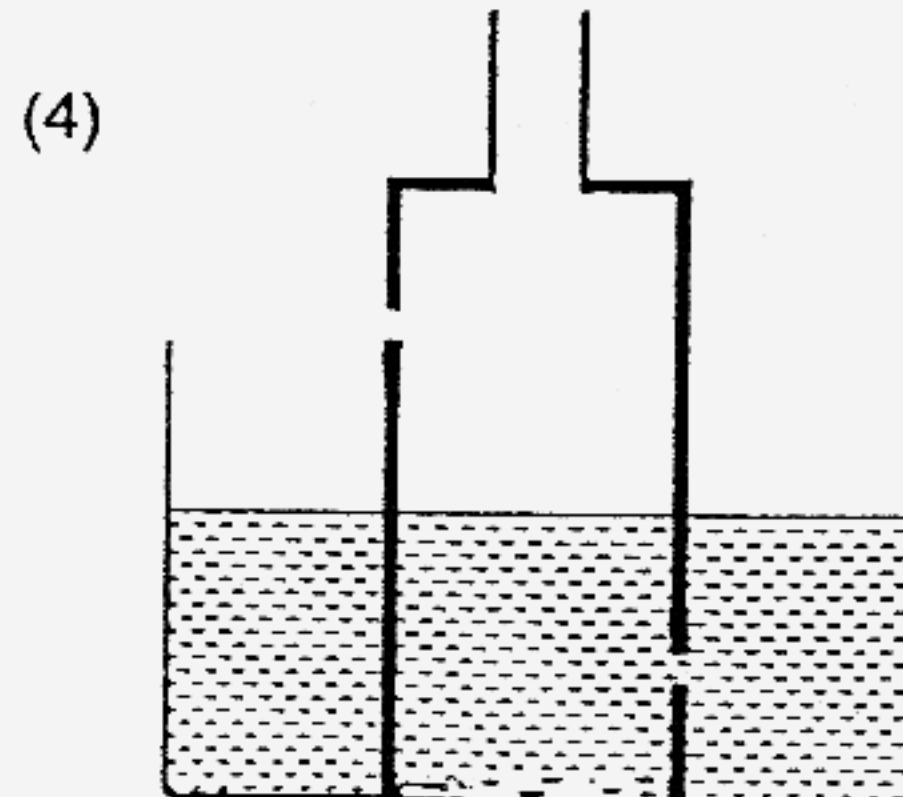
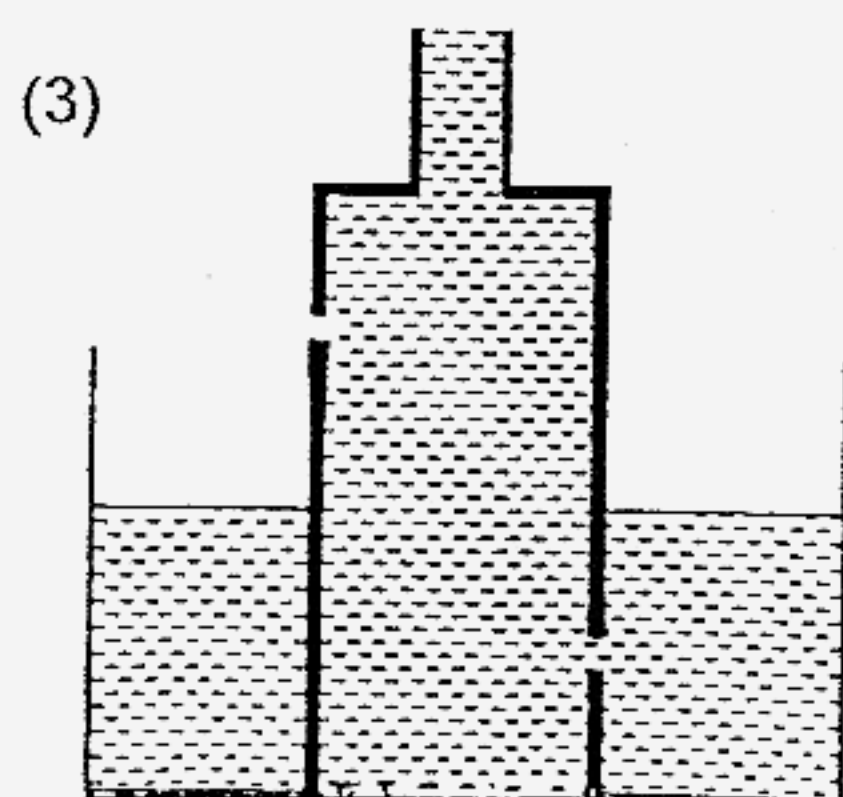
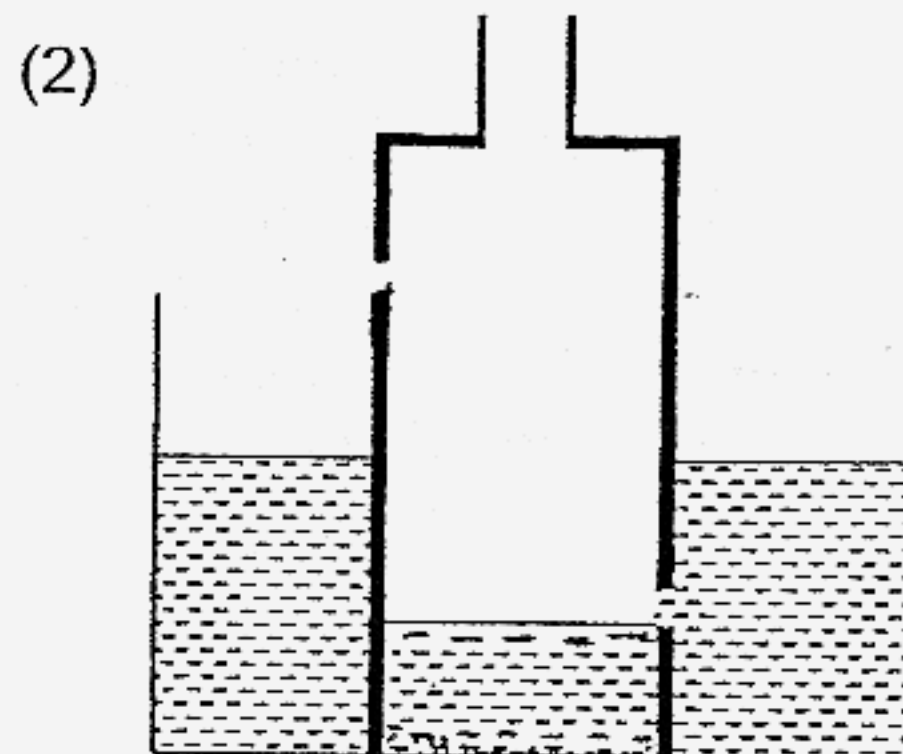
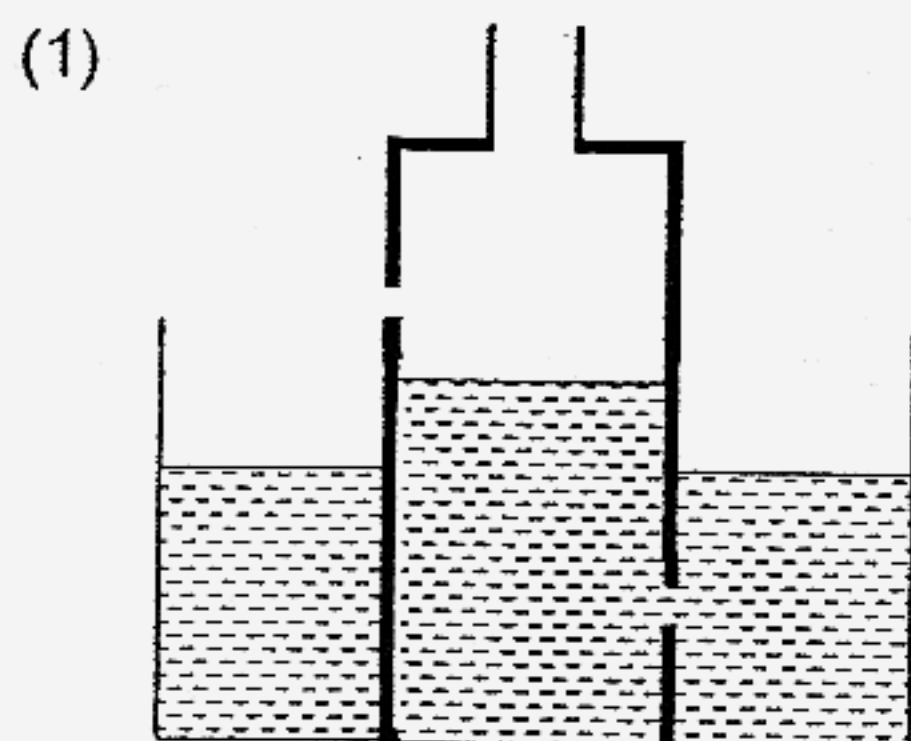

23. The diagram below shows the various stages in the water cycle.

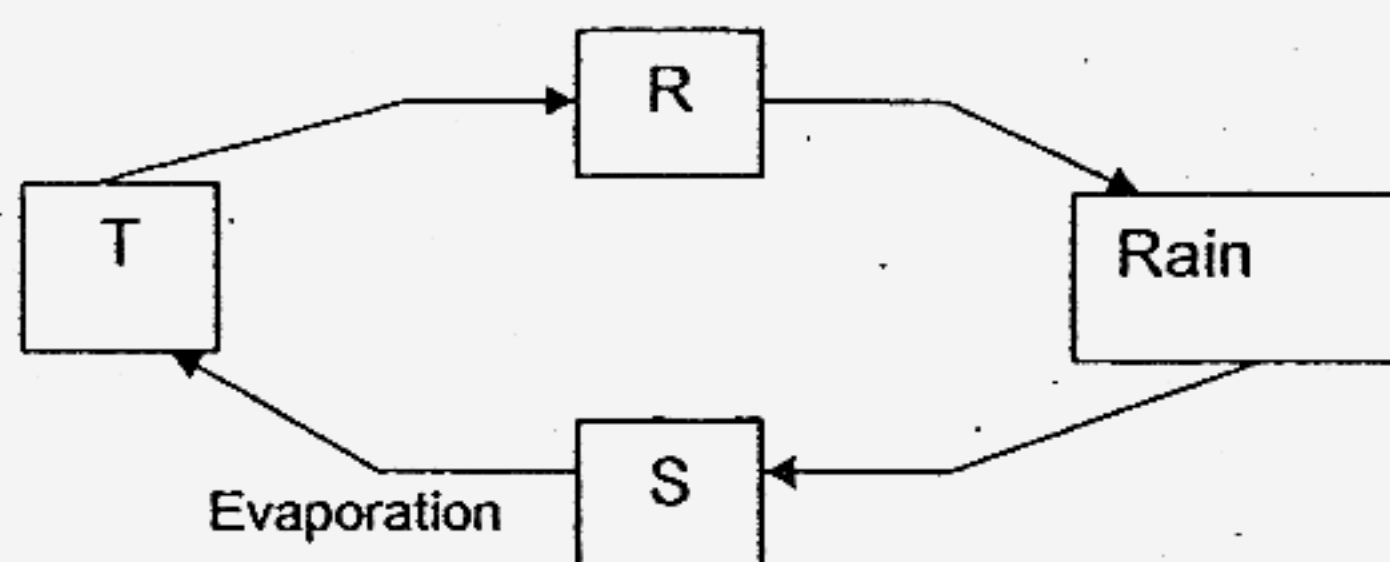

In which stage(s), R, T or S, in the water cycle does/do water have definite volume but no definite shape?

- | | |
|------------------|------------------|
| (1) S only | (2) R and S only |
| (3) T and R only | (4) R, S and T |
24. A sheet of paper and a book as shown below were dropped from the same height.



Which one of the following statements best explains why the book fell faster than the paper ?

- (1) There was no air resistance acting on the book.
- (2) The gravitational force acting on the paper was greater than its air resistance.
- (3) The weight of the book was greater than the air resistance it encountered as it was falling.
- (4) The air resistance acted in the same direction as the weight of the falling paper.

25. Four different metals S, T, U and V were used to make 3 sets of rings as shown below. All the sets of rings were similar except for the material used.

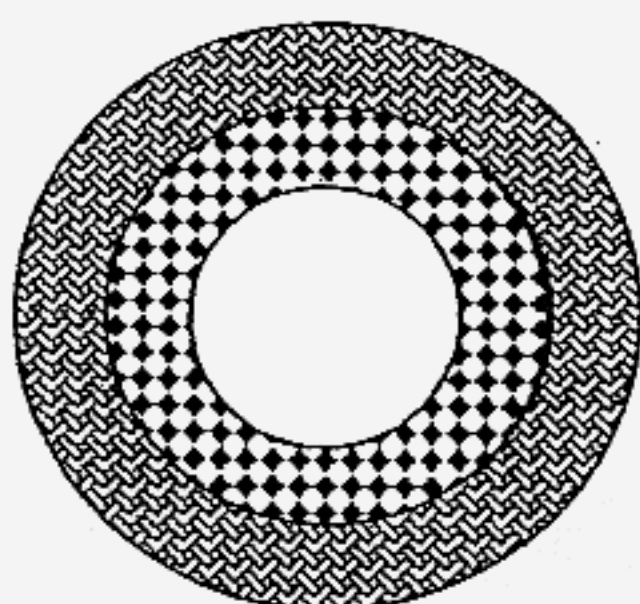

Set 1

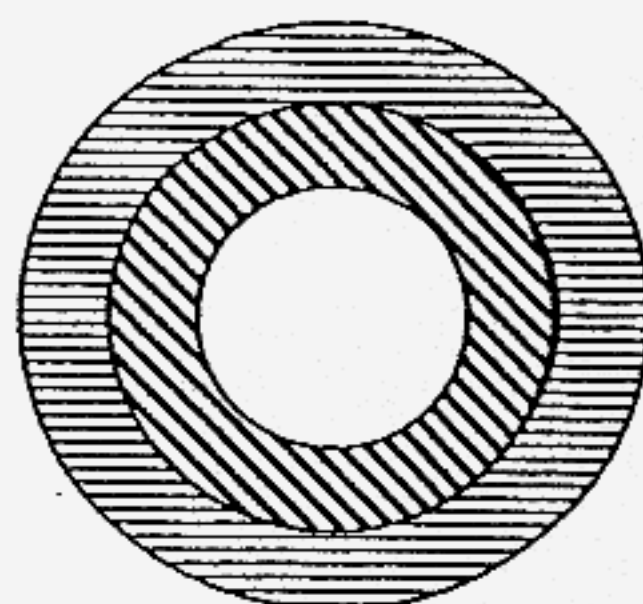

Set 2

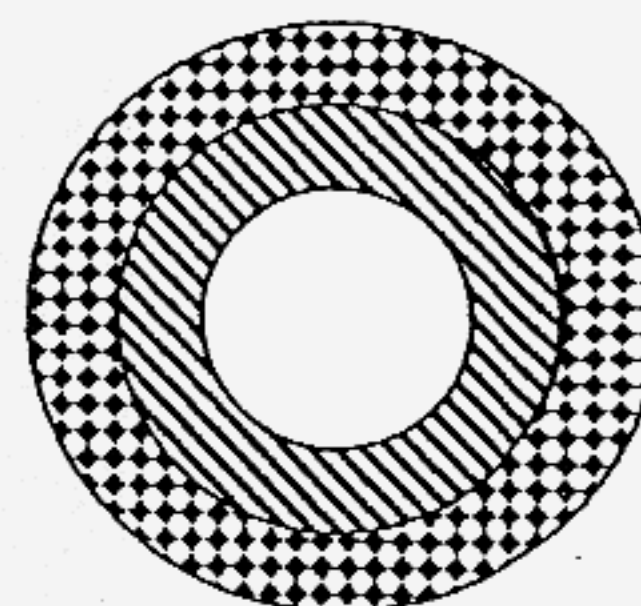

Set 3

Legend for cross-section of rings



Metal S



Metal T



Metal U



Metal V

At 25°C, all the inner ring of each set could just fit into the outer ring and still be pulled out with some effort. The sets of rings were heated evenly from 25°C to 50°C and the observations were recorded in the table below.

At 40°C		
Set 1	Set 2	Set 3
Ring T fell out of ring S easily.	Ring U could not be pulled out even with great effort.	Ring U could just fit into outer ring and still be pulled out with some effort.

Based on the above observations, which metal S, T, U or V expanded the most when heated ?

(1) S

(3) U

(2) T

(4) V

26. The diagram below shows Ali in a dark room and Peter outside in the daylight.

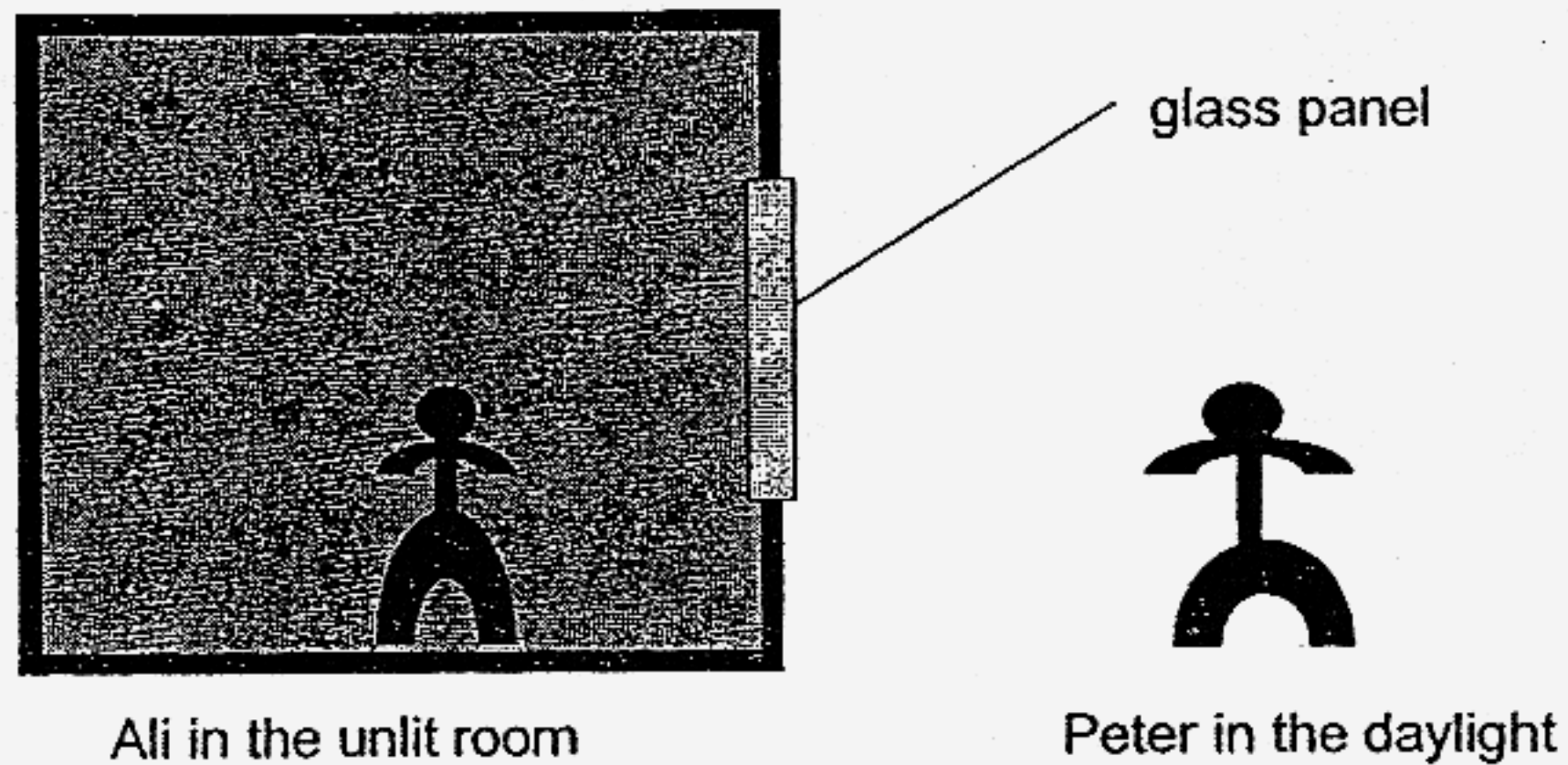

Ali who was in the dark unlit room, looked through a glass panel and could not see Peter who was outside in the daylight. Similarly, Peter could not see Ali when he looked into the unlit room.

Which of the following statement(s) explain/s the above observations ?

- A There was no mirror behind Ali.
- B Light could not pass through the glass panel
- C The glass panel reflected most of the daylight.
- D Little or no light was reflected from Ali to the eyes of Peter.

- (1) A only
- (3) B and C only

- (2) A and B only
- (4) C and D only

27 Two magnets were arranged as shown below.

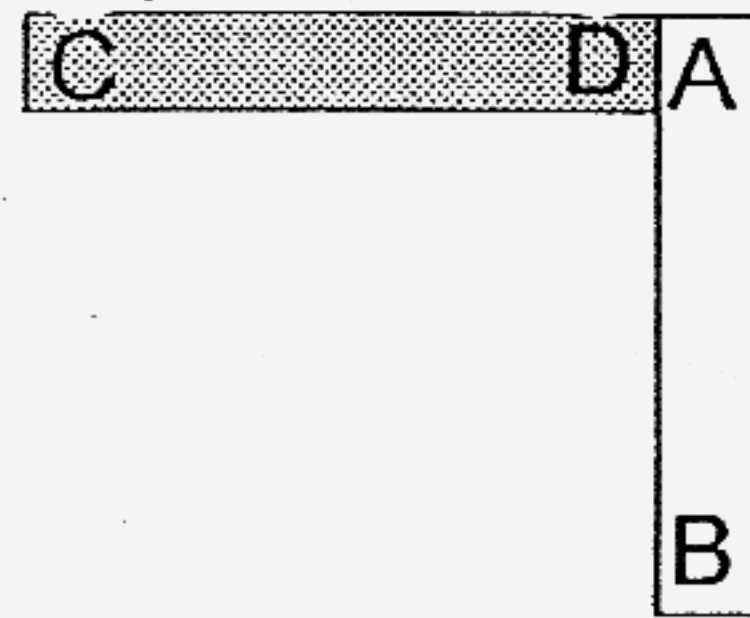

Both magnets were broken to form 4 smaller pieces of magnets. Which one of the following is a possible arrangement of the 4 pieces of magnets ?

(1)

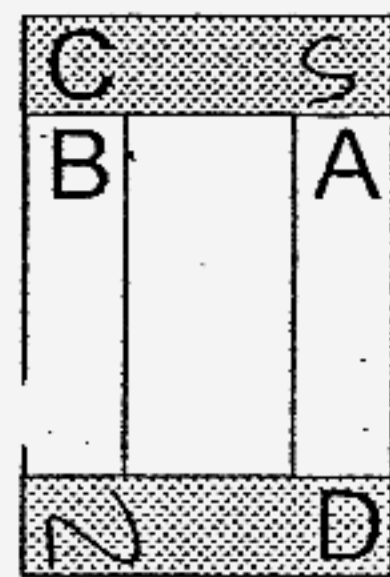

(2)

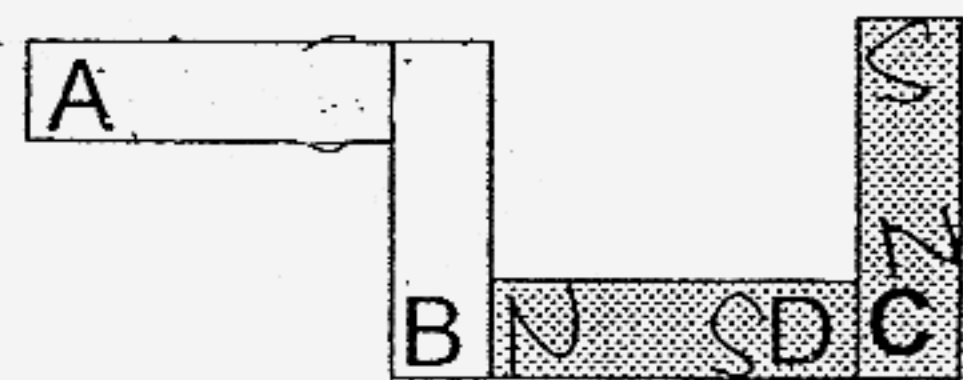

(3)

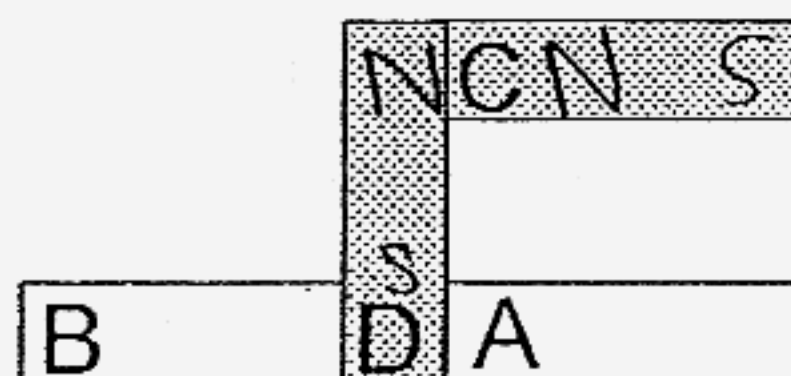

(4)

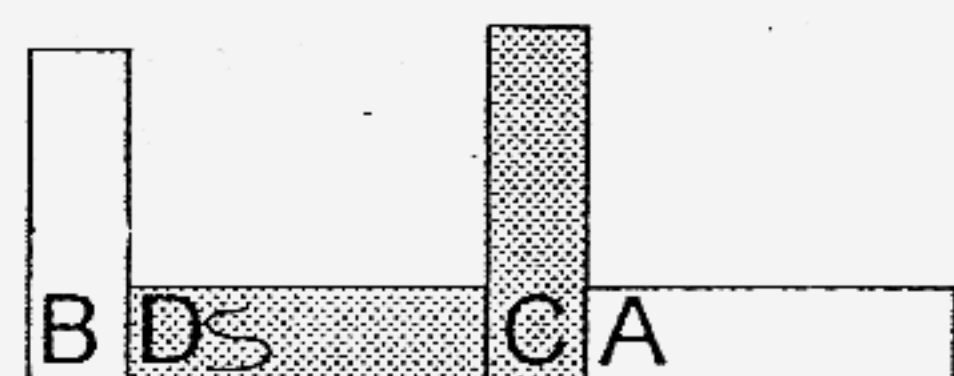

- 28 The diagrams below show a 50 kg load being pulled along ramps made of different materials.

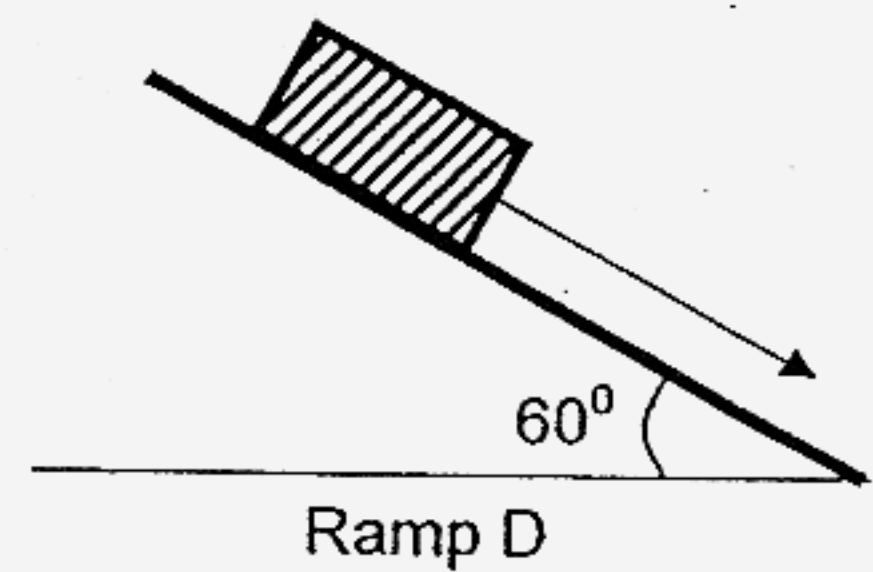
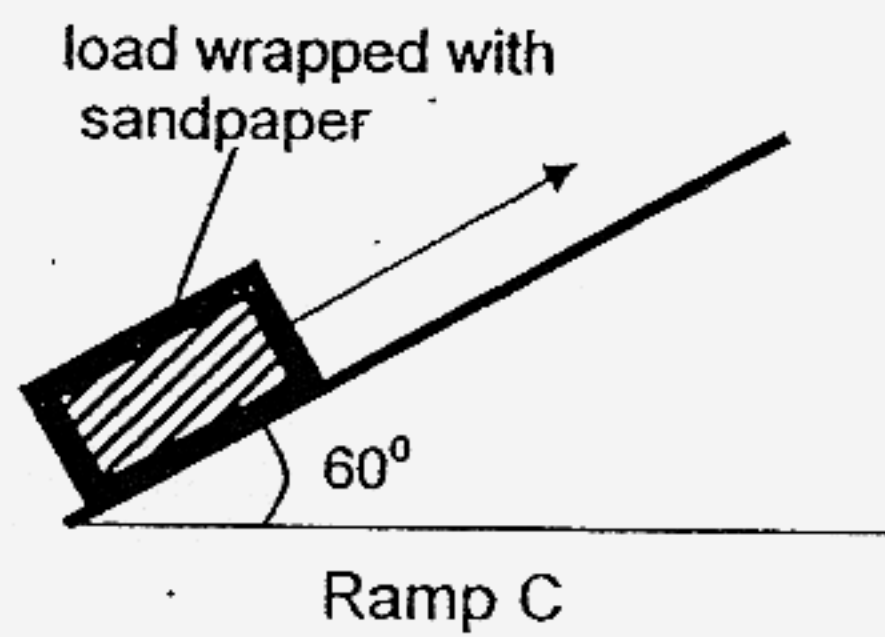
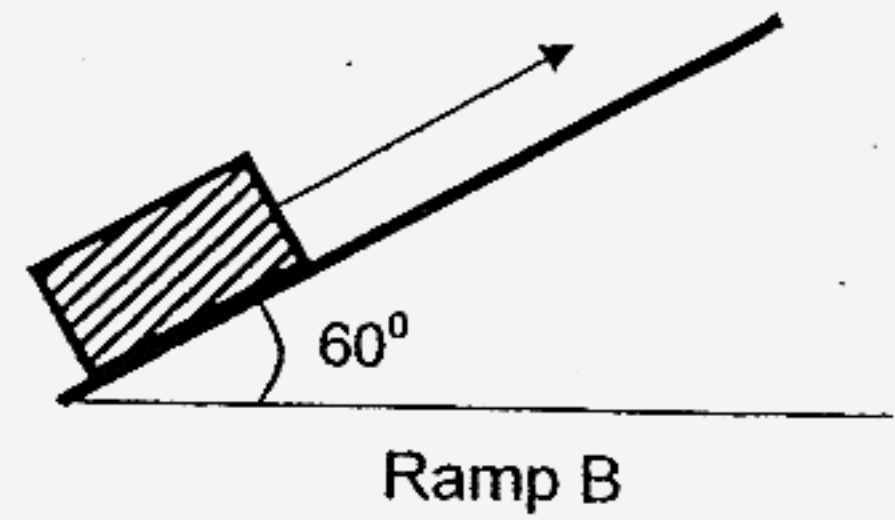
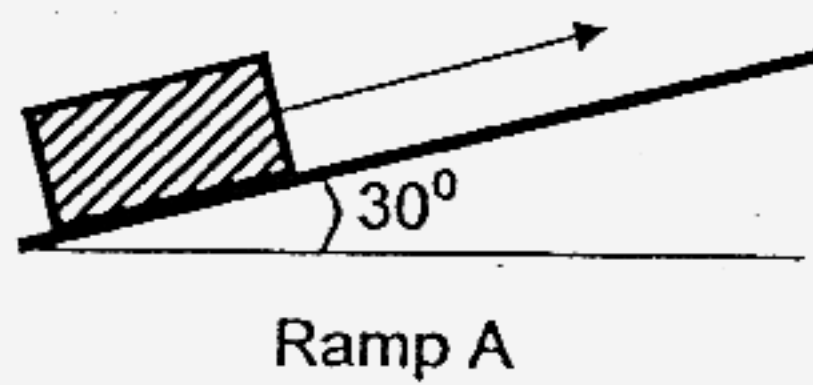

If the effort needed to move the load along all the 4 ramps is the same, order the texture of the ramp from the smoothest to the roughest?

- (1) C, B, A, D
(3) B, D, C, A

- (2) D, A, B, C
(4) A, C, D, B

- 29 A rope snaps when a load of 50 kg is hung from it. This rope is used in all the pulley systems below and one end is tied to a metal bar. All the pulleys have a weight of 1 kg.

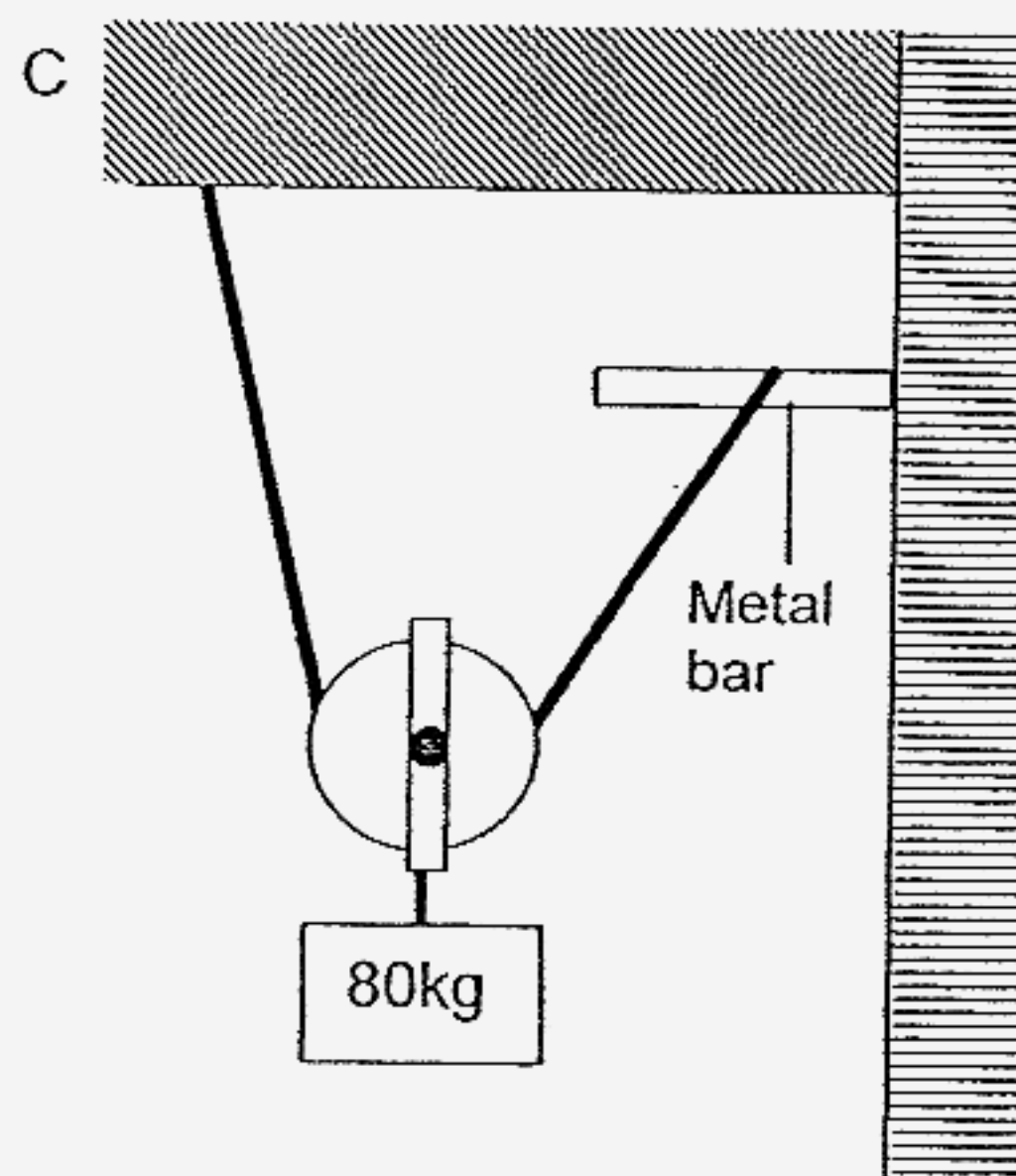
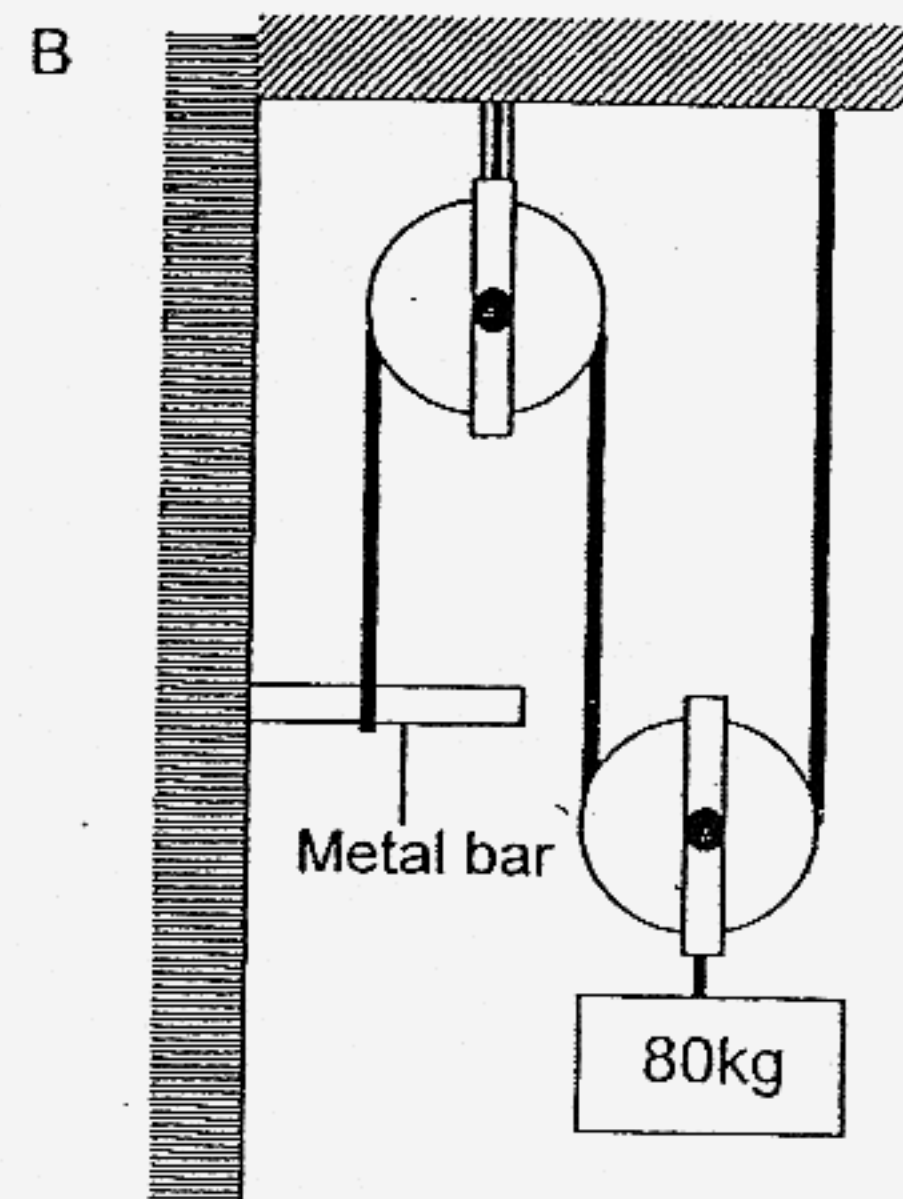
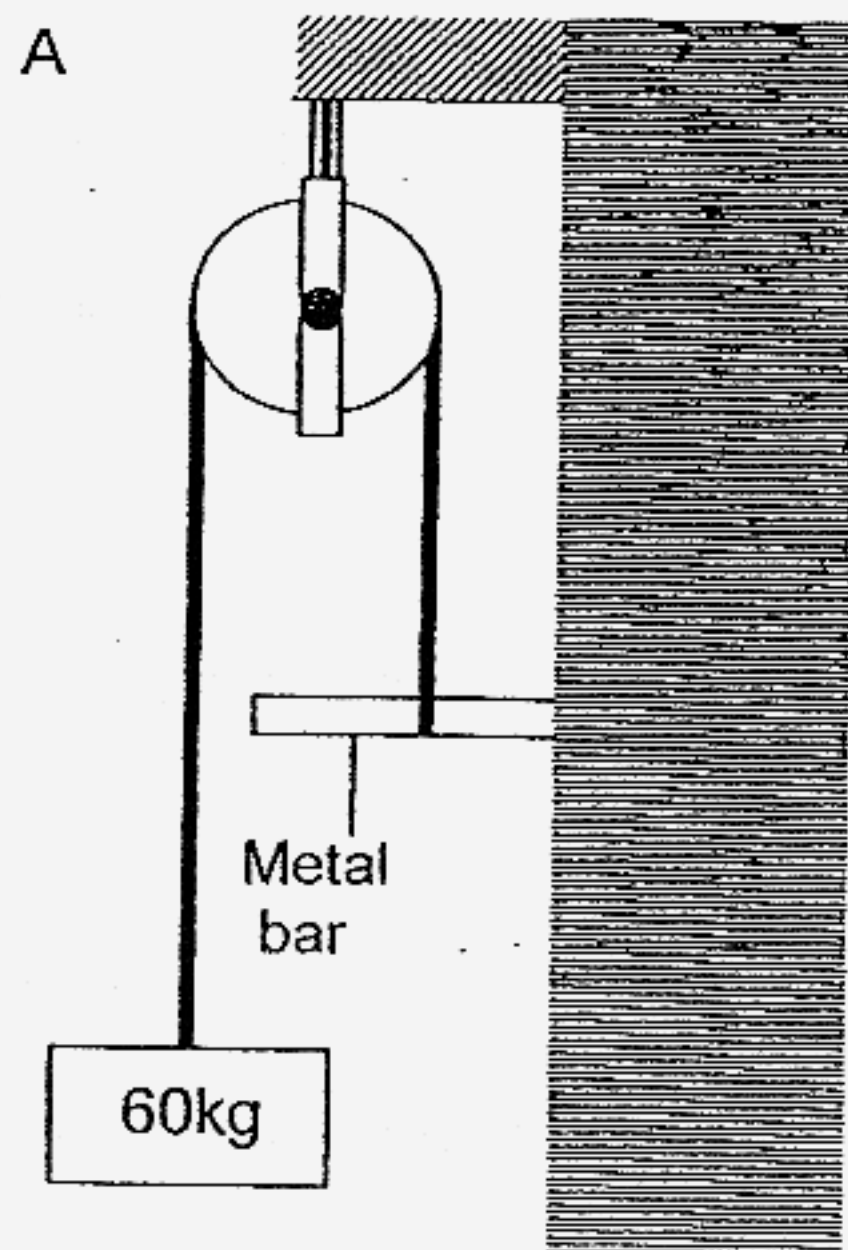

In which of the above set-up(s) would the rope snap?

- (1) A only
- (2) C only
- (3) A and B only
- (4) A, B and C

30. Below is some information about Venus and Earth

	Venus	Earth
Time taken to make 1 complete rotation	243 Earth days	1 Earth day
Time taken to make 1 complete revolution	225 Earth days	365 Earth days
Direction of spin around axis	Clockwise	Anticlockwise

1 Earth day = 24 hours

Based on the above information, which of the following statement(s) is/are **definitely** true ?

- A A day on Venus is longer than its year.
- B Both planets take different time to make 1 revolution because they spin in different directions.
- C Venus takes a shorter time than Earth to complete 1 revolution because it spins faster than Earth.

(1) A only

(3) A and B only

~~(2)~~ B only

(4) A, B and C

NANYANG PRIMARY SCHOOL

PRIMARY 6 SCIENCE

PRELIMINARY EXAMINATION 2006

BOOKLET B

Date : 24 August 2006

Duration : 1 h 45 min

Name : _____ ()

Class: Primary 6 ()

Marks Scored:

Booklet A:		60
Booklet B :		40
Total :		100

Parent's signature:

**DO NOT OPEN THIS BOOKLET UNTIL YOU ARE TOLD TO DO SO.
FOLLOW ALL INSTRUCTIONS CAREFULLY.**

Booklet B consists of 16 printed pages including this cover page.

Section B (40 marks)

Write your answers to questions 31 to 46 in the spaces provided.
Marks will be deducted for misspelt key words.

31. Adam wants to find out whether a chemical, liquid X, could prevent fish from laying eggs. He set up an experiment using 20 identical fishes as indicated in the table below.

Conditions	Tank A	Tank B
No. of fish	5 male 5 female	5 male 5 female
Water plants	Present	Present
Amount of sunlight	Moderate	Moderate
Food given	Once daily	Once daily
Amount of liquid X	Injected 1 ml to all female fish	No injection carried out

A week later, he noticed fish eggs present among the water plants in tank B but none was observed in tank A.

- (a) What was the purpose in setting up tank B? (1 mark)

Based on his results, Adam concluded that liquid X could indeed prevent fish from laying eggs.

- (b) State another reason that could have prevented the fish from laying eggs. (1 mark)

32. Daniel made an observation about three types of plants, X, Y and Z, growing on a small island. He made a rough sketch of the locations where these plants were found. Several months later, he returned to the island and again identified the locations where these plants were found. His observations are recorded in the diagrams below.

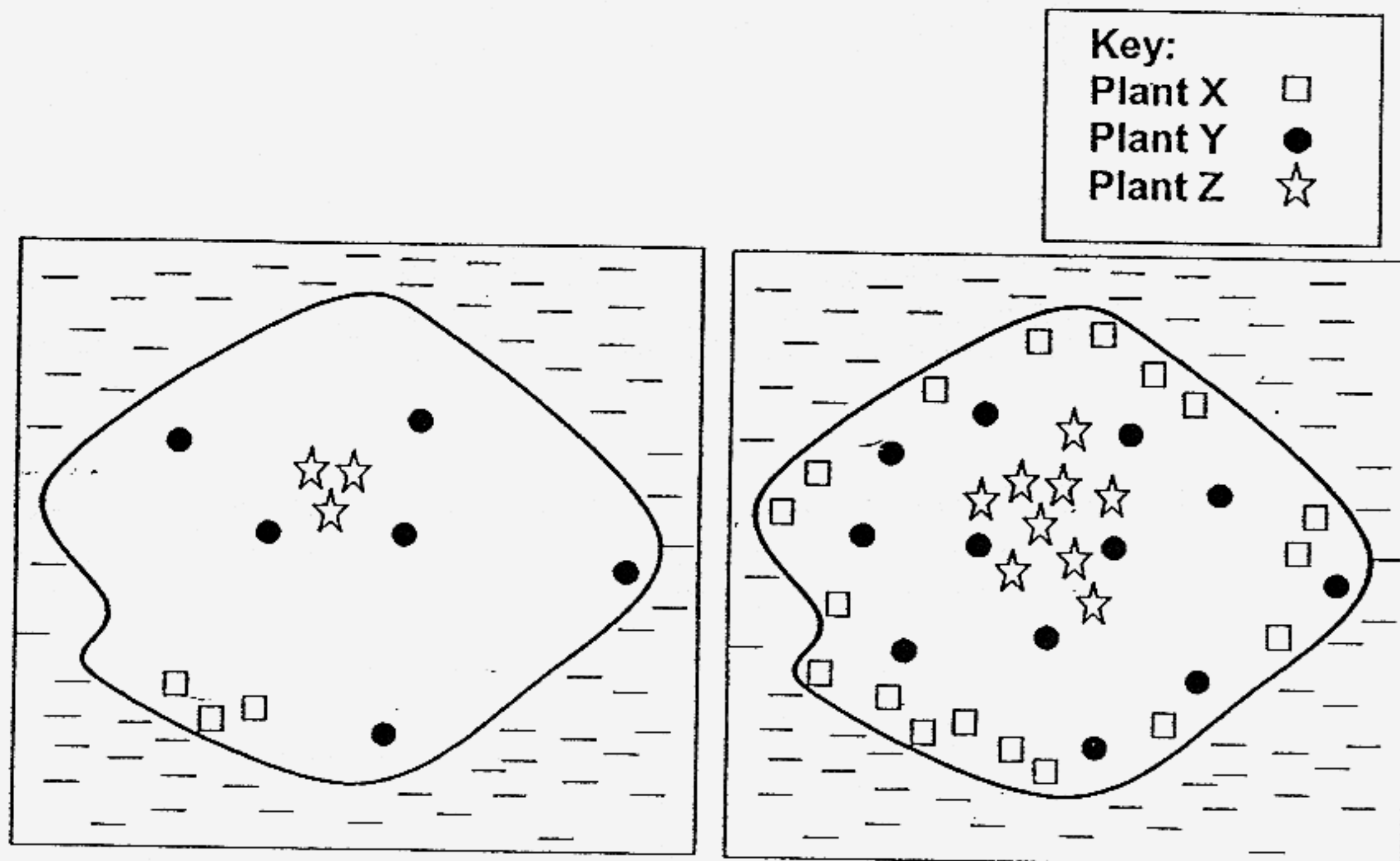

First observation

Several months later

- (a) State the methods of dispersal for plants Y and Z. (1 mark)

Plant Y: _____

Plant Z: _____

- (b) (i) Give an example of plant X (1/2 mark)

- (ii) Describe an important characteristic of the fruit of plant X that helps in its dispersal. (1/2 mark)

33. The diagram below shows the proportion of oxygen and carbon dioxide in the blood found at four different locations in the human circulatory system.

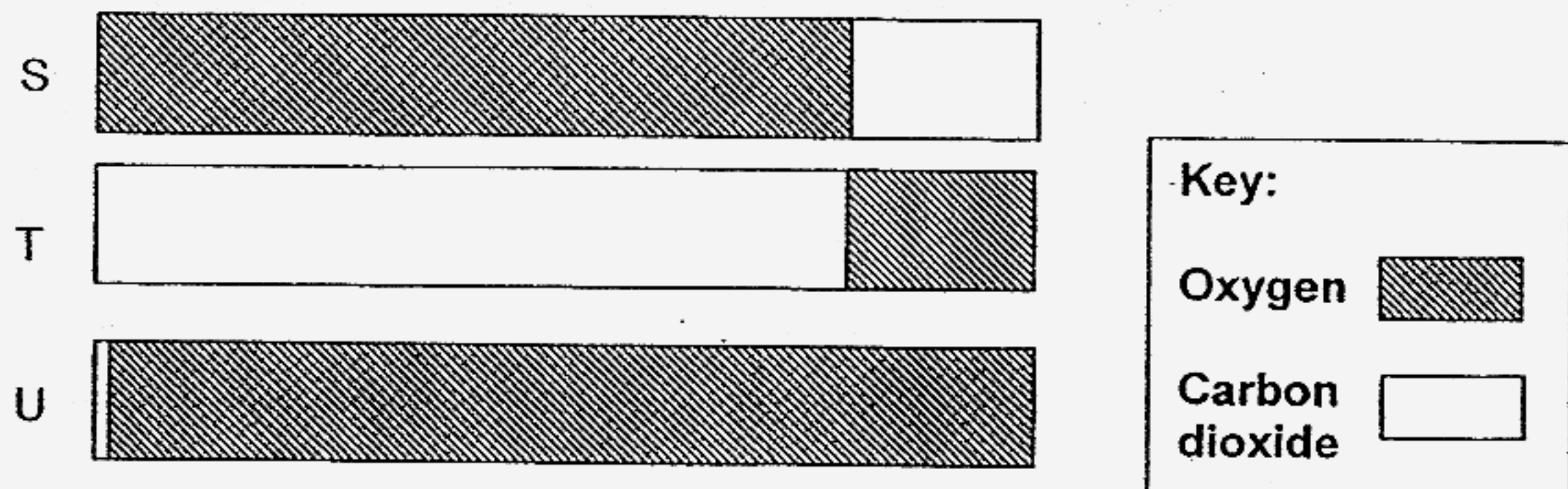

In the following simplified circulatory system, label 'S', 'T', 'U' ~~and V~~ in all four boxes based on the information given in the graph above. Each letter may be used more than once. (2 marks)

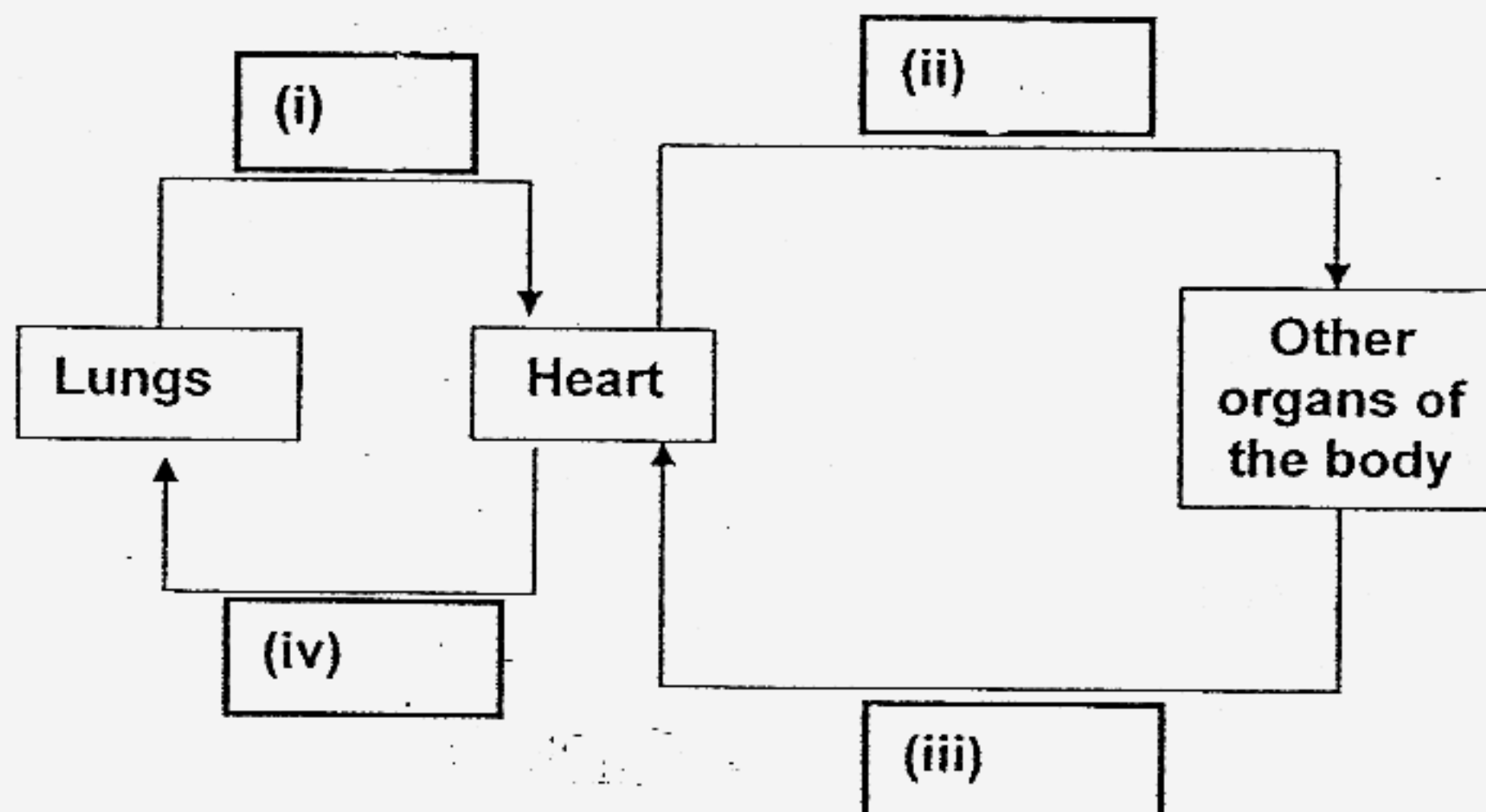

34. Cindy was given a cell from a multicellular organism to look at under the microscope. Her teacher had removed a part from the cell. She drew the cell she observed but could not identify it.

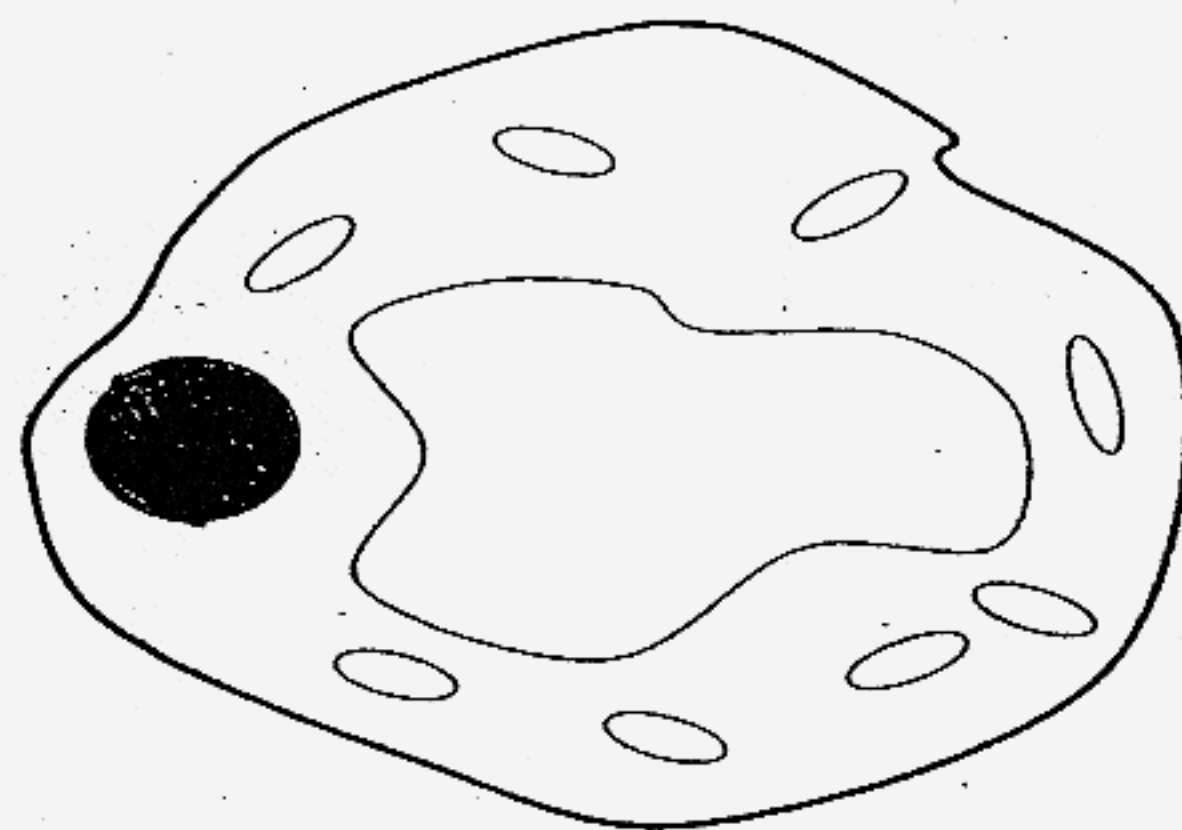

- (a) Name the part of the cell that was removed. (1 mark)
- _____
- (b) Other than the part that was removed, what other observation allowed Cindy to confirm the type of organism the specimen was taken from? (1 mark)
- _____
- _____

35. Study the food web given below.

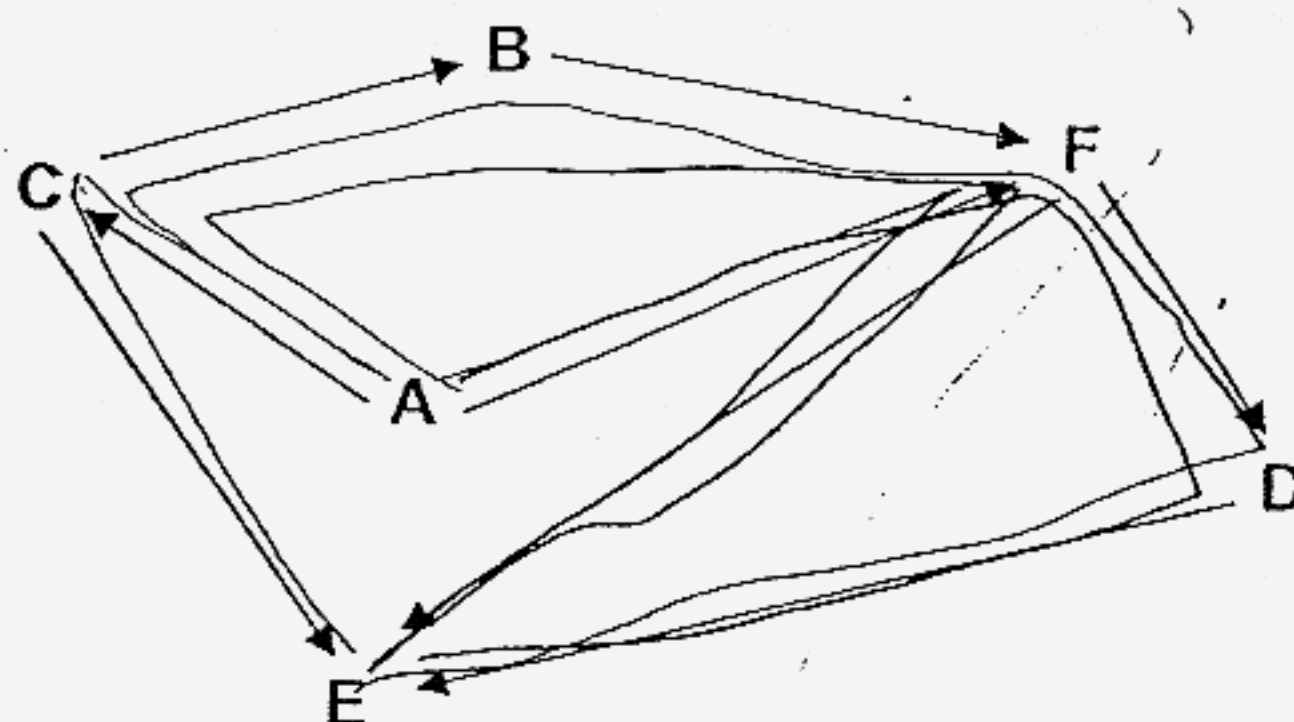

The following statements are based on the food web above. Indicate whether each statement is true (T), false (F) or not possible to tell (N) using a tick (✓).

Statements		T	F	N
(i)	D is a snake.			
(ii)	F feeds on animals only.			
(iii)	A is the only plant in this food web.			
(iv)	There are six food chains in this web.			

36. Zack planted 5 different seeds in a small plot of sandy soil as shown in the map below.

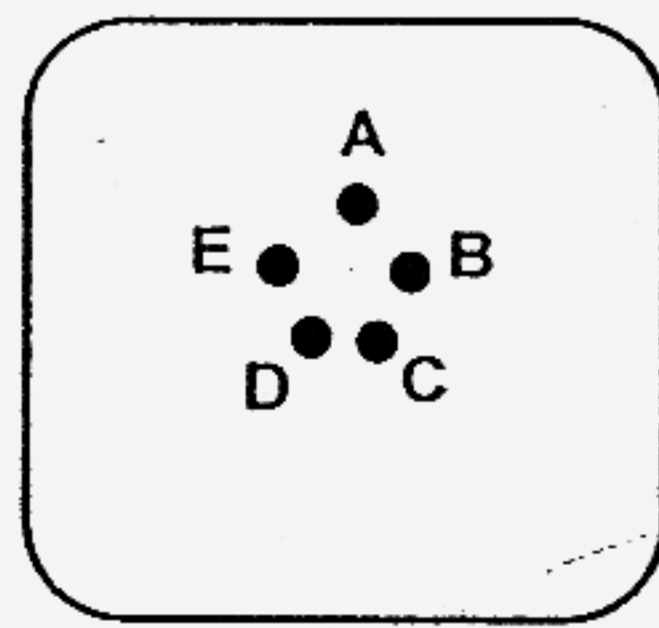

Plot of land

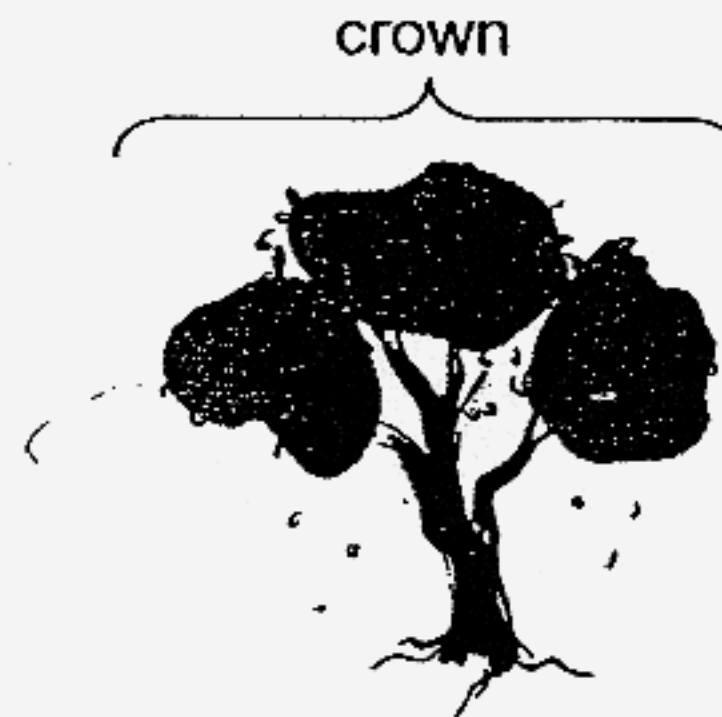

In the first few weeks after germination, all the seeds had a similar rate of growth. Zack was also given a general description of each plant when they are fully grown.

Seed	Crown	Roots
A	Wide	Deep
B	Wide	Shallow
C	Wide	Deep
D	Small	Shallow
E	Small	Deep

After 6 months, he noticed that plant A and C were taller than the other three plants.

- (a) State two possible reasons to explain why the rate of growth of plants B, D and E were slowed down by plants A and C. (2 marks)

(i) _____

(ii) _____

- (b) Suggest a way to make it possible for plant E to grow big and tall. (1 mark)

37. The diagram below shows the conditions found in a pond community.

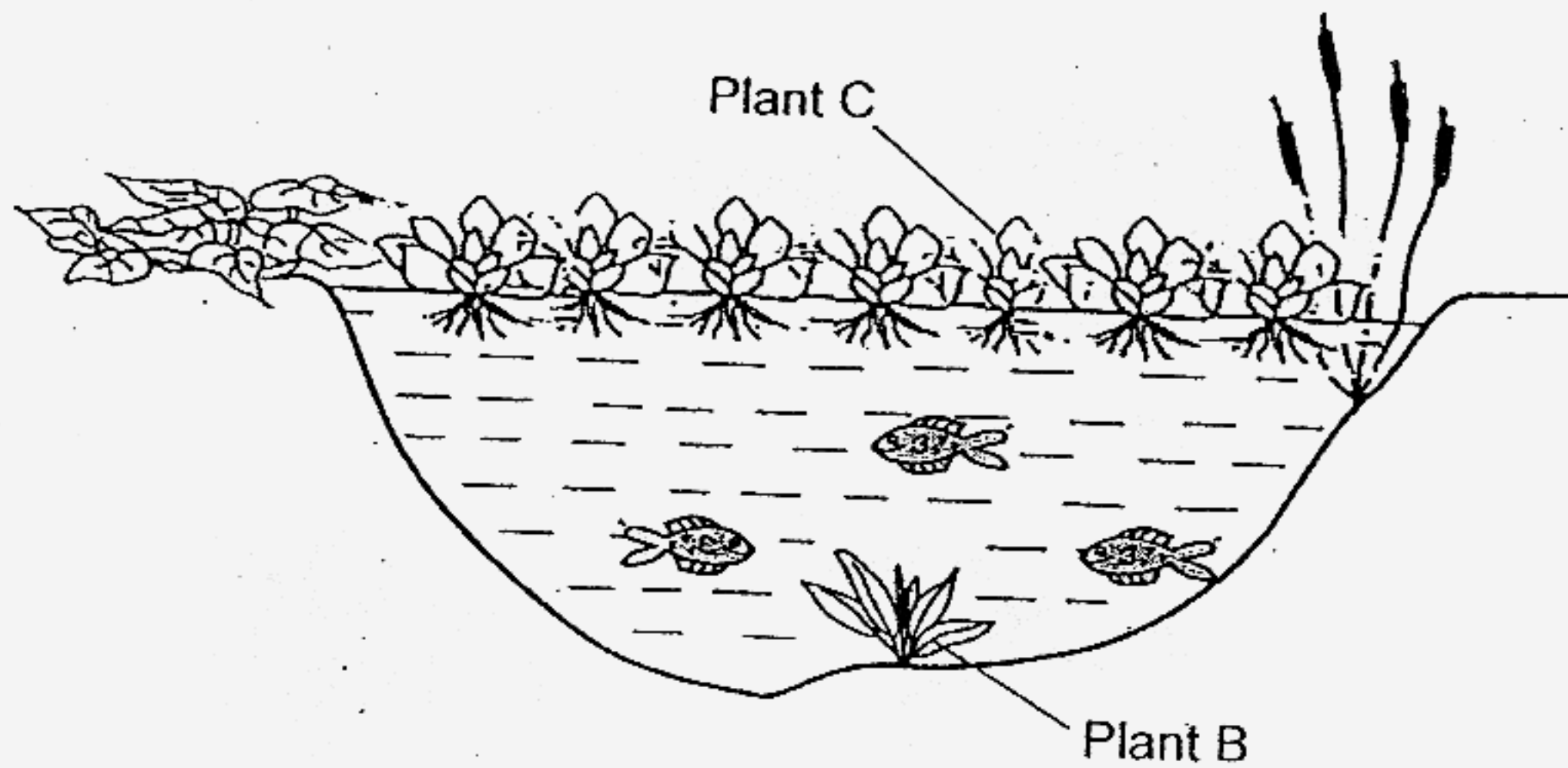

- (a) (i) What would happen to the fishes after several months? (1 mark)

- (ii) Explain your answer in (i) (1 mark)

- (b) More fishes were then added to the pond and Plant B together with half the number of plants C were removed. Explain the effect this had on the fishes in the pond. (1 mark)

38. (a) Study the beaks of the birds in the diagram below.

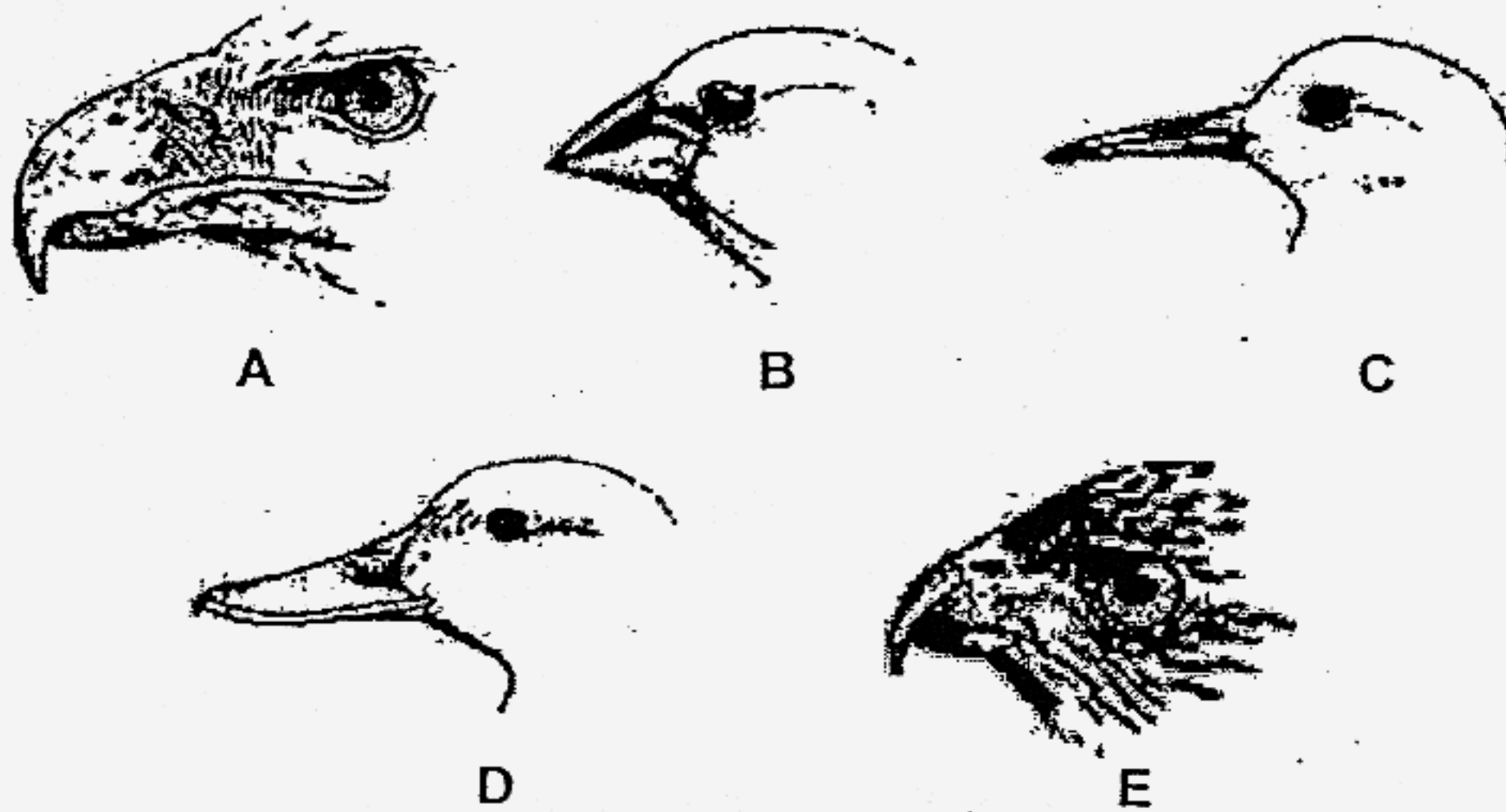

- (i) Which birds above most likely use their beaks in the same way to get their food? (1 mark)

The diagram below shows a flower.

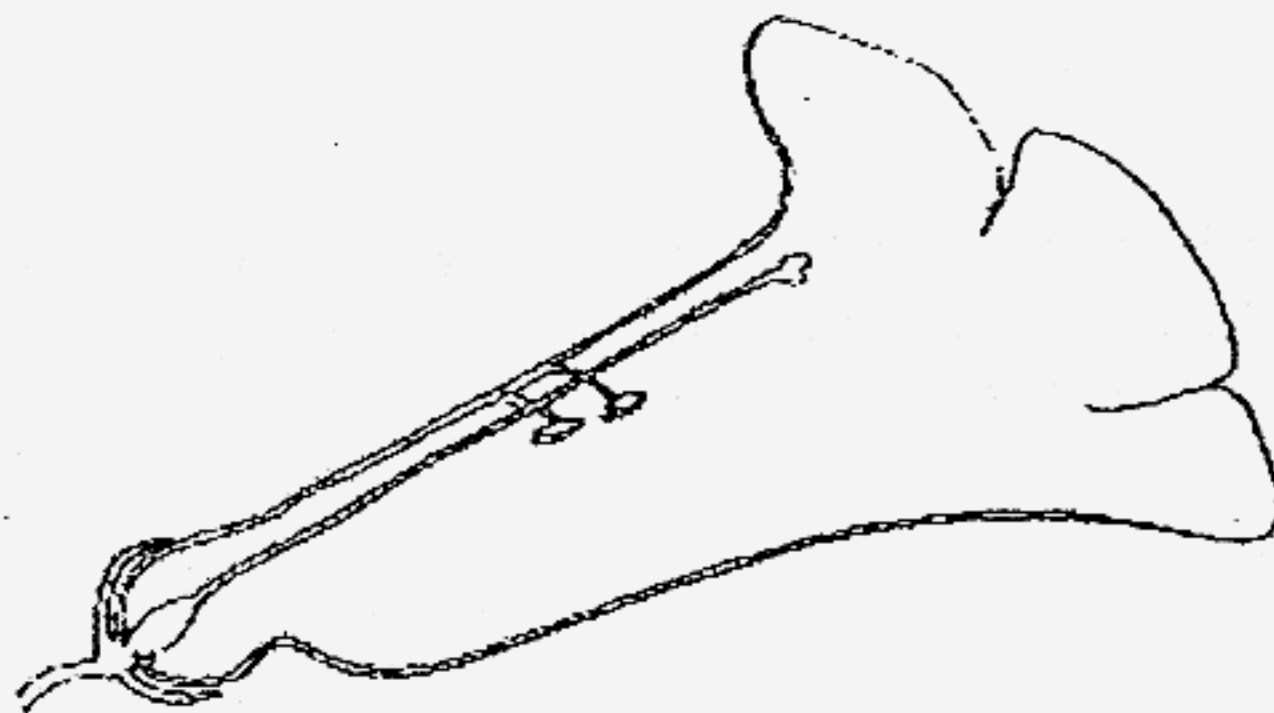

- (ii) Which of the above birds is likely to feed on the nectar of the flower? (1 mark)

- (iii) Explain your answer in (ii) (1 mark)

The diagram below shows a vulture.



- (iv) With respect to its head, explain why the vulture is not adapted for survival in the winter. (1 mark)
-
-

39 Mary conducted an experiment according to the following procedure.

- Fill half of the tin can with dry sand.
- Measure the initial temperature of the sand.
- Cover the tin can with the lid.
- Shake the can of sand vigorously for 3 minutes continuously.
- Remove the lid and measure the final temperature of the sand.

- (a) Mary noted that the final temperature of the sand was higher than its initial temperature. Explain her observation. (1 mark)
-
-

- (b) When the experiment was repeated with a plastic can with lid, it was observed that the final temperature of the sand was even higher than that of the first experiment. Explain why this was observed. (1 mark)
-
-

- 40 Using a windmill to generate electricity is not cheap as a large number of windmills must be built over a huge area to generate sufficient electricity. Besides the cost and extensive use of land, state one advantage and one disadvantage of using windmill to generate electricity

Advantage: _____

Disadvantage: _____

- 41 Two identical balls, A and B were released from the same height and allowed to roll along tracks made of similar material. The balls were allowed to roll beyond points P and Q.

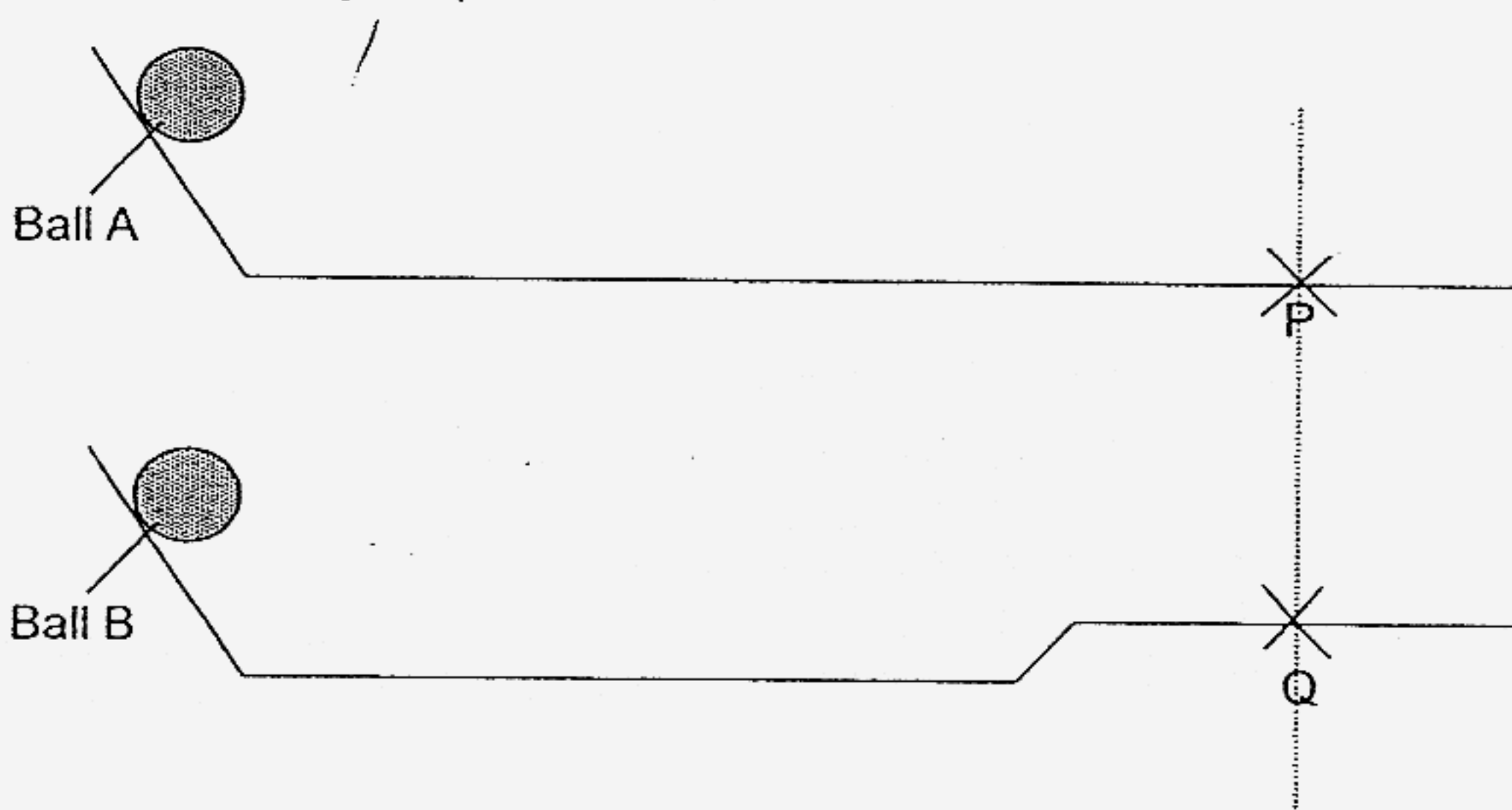

Explain whether Ball A travelled faster, slower or at the same speed as Ball B when at points P and Q respectively. (2 marks)

- 42 (a) When a drop of alcohol was applied on the skin, it felt cool and the alcohol disappeared after a short while. In the table below, put a tick (✓) in the correct boxes to indicate whether the alcohol and water that are mentioned above, gained or lost heat. (1 mark)

	Heat gained	Heat lost
Drop of alcohol		
Skin		

Ether is a liquid which vaporizes very quickly at room temperature. Some ether was poured into a glass beaker and its volume was noted. The beaker of Ether was covered with a lid and placed in a bigger beaker of water as shown below.

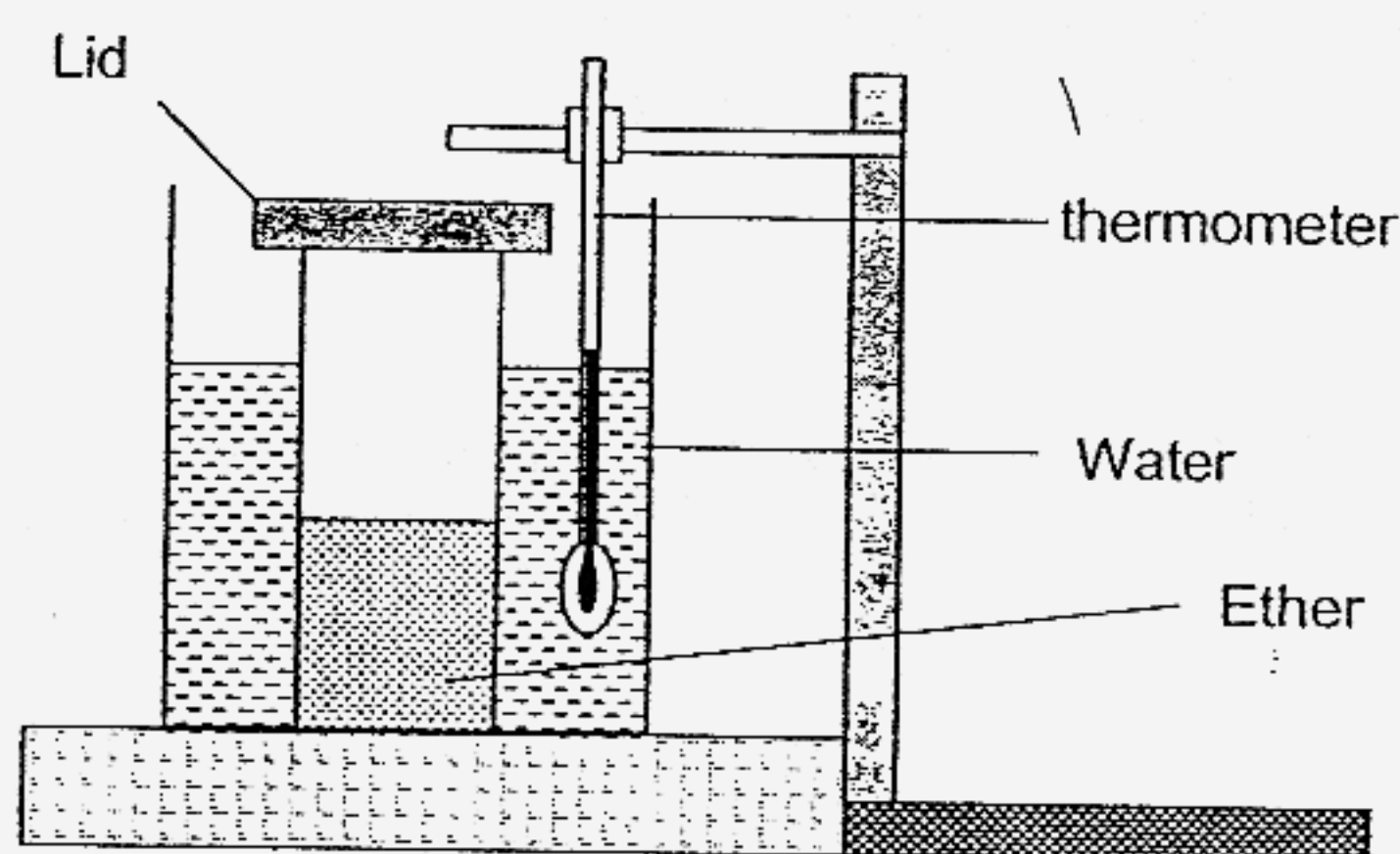

The temperature of the water was measured before the lid covering the beaker of Ether was removed. 5 minutes after removing the lid, it was noticed that both the volume of ether and the temperature of the water decreased.

- (b) Explain why there was a drop in temperature of the water 5 minutes after the lid was removed. (2 marks)

43. The diagram below shows a hydroelectric power station. A and B are points along the path of flow of water from the dam to the power station.

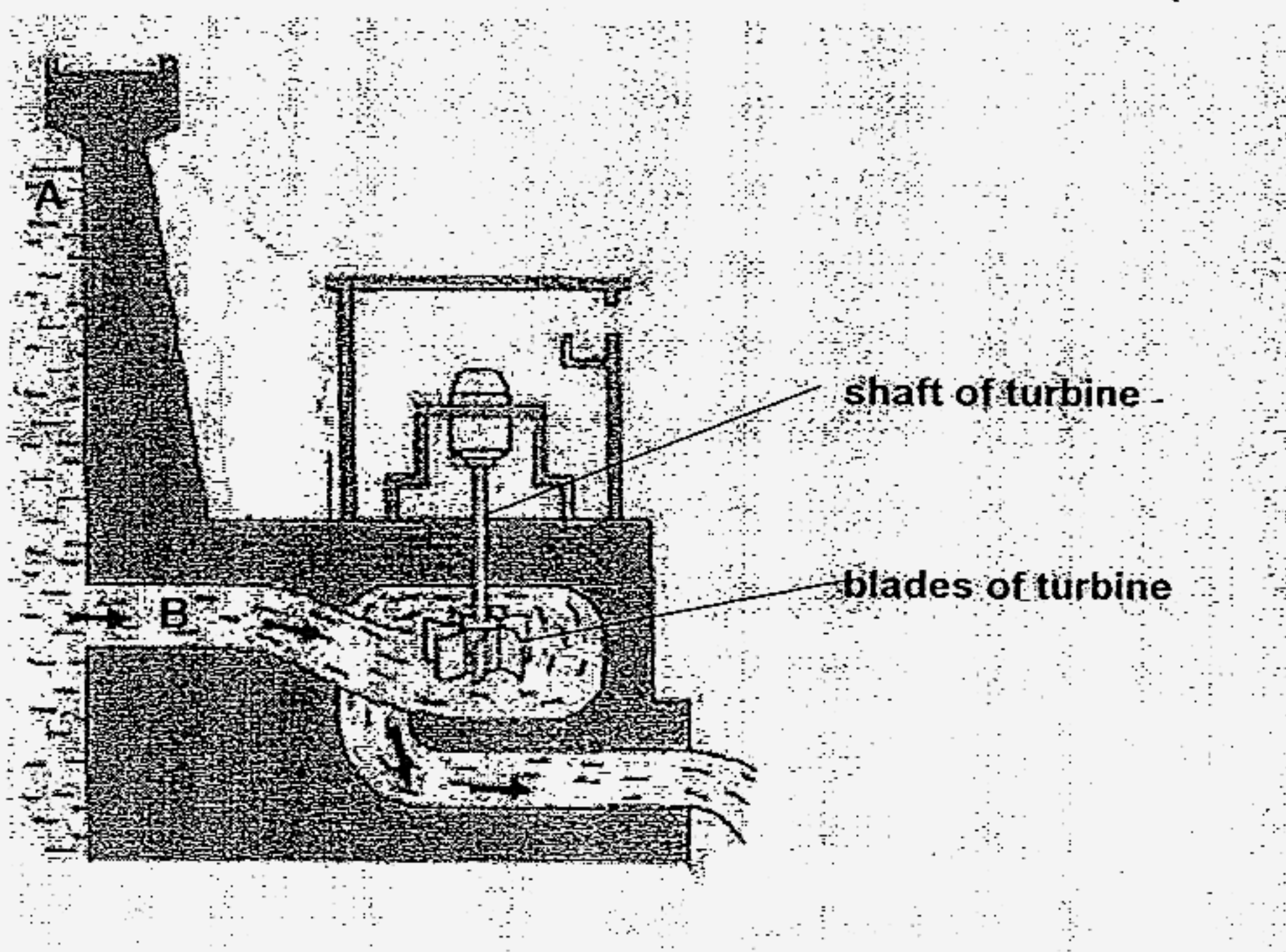

- (a) Describe the energy changes taking place for such a power plant by filling the energy chain below with the correct words.

(1 mark)

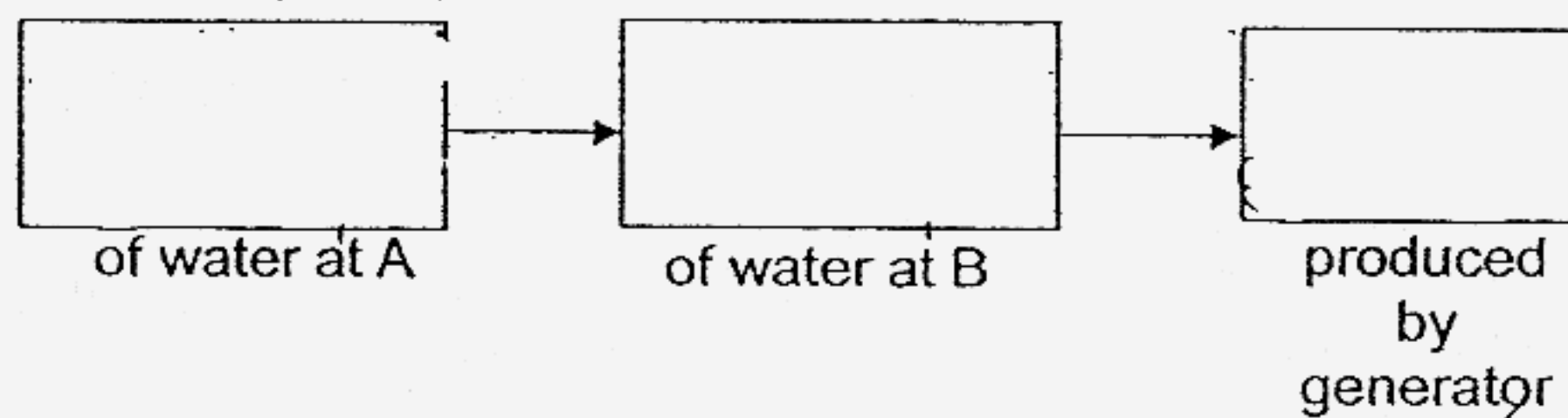

- (b) Identify the simple machine formed by the blades and shaft of the turbine.

(1 mark)

The shaft and blades of the turbine are made of different materials. The temperature of water in the dam is much higher in summer than in spring. It is also noticed that the rate of electricity production is higher in summer than spring though the depth of the water stored in the dam is the same for both seasons.

- (c) Assuming that the number of times the water released from the dam remains the same, explain why ~~if~~ there is ~~any~~ difference in the rate of electricity production in the two seasons. (2 marks)

44. The diagram below shows a set-up which Paul used for an investigation.

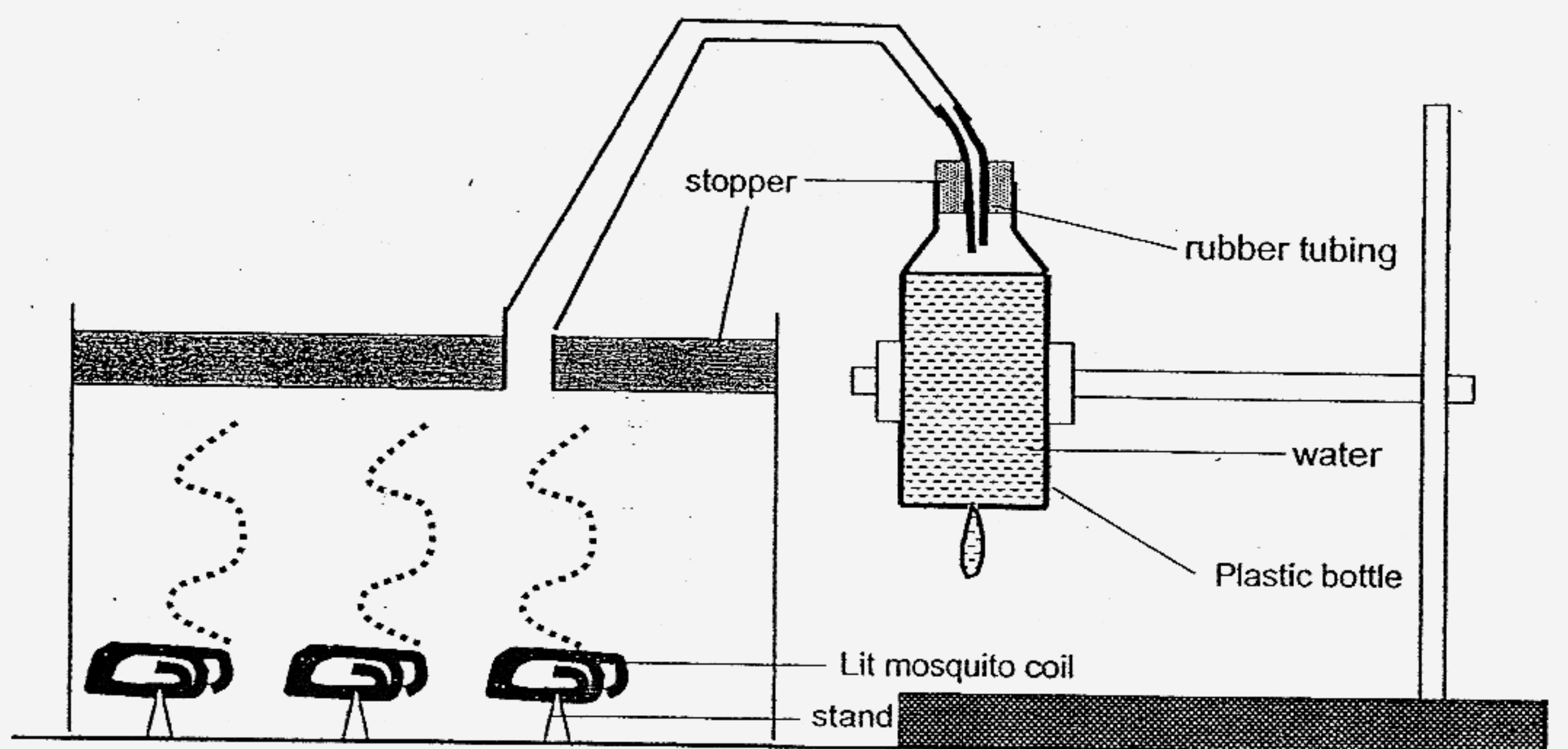

After the mosquito coils were lighted, a sticky tape covering the hole at the bottom of the bottle was removed for the water to flow out.

- (a) Explain how the smoke from the mosquito coils was drawn into the bottle. (1mark)

- (b) Paul replaced the water in the plastic bottle with limewater. If the rate at which the limewater flowed out remained the same, state one other observation he would make when he used the set-up for his investigation? (1mark)

45. Study Circuit 1 which is not drawn to scale.

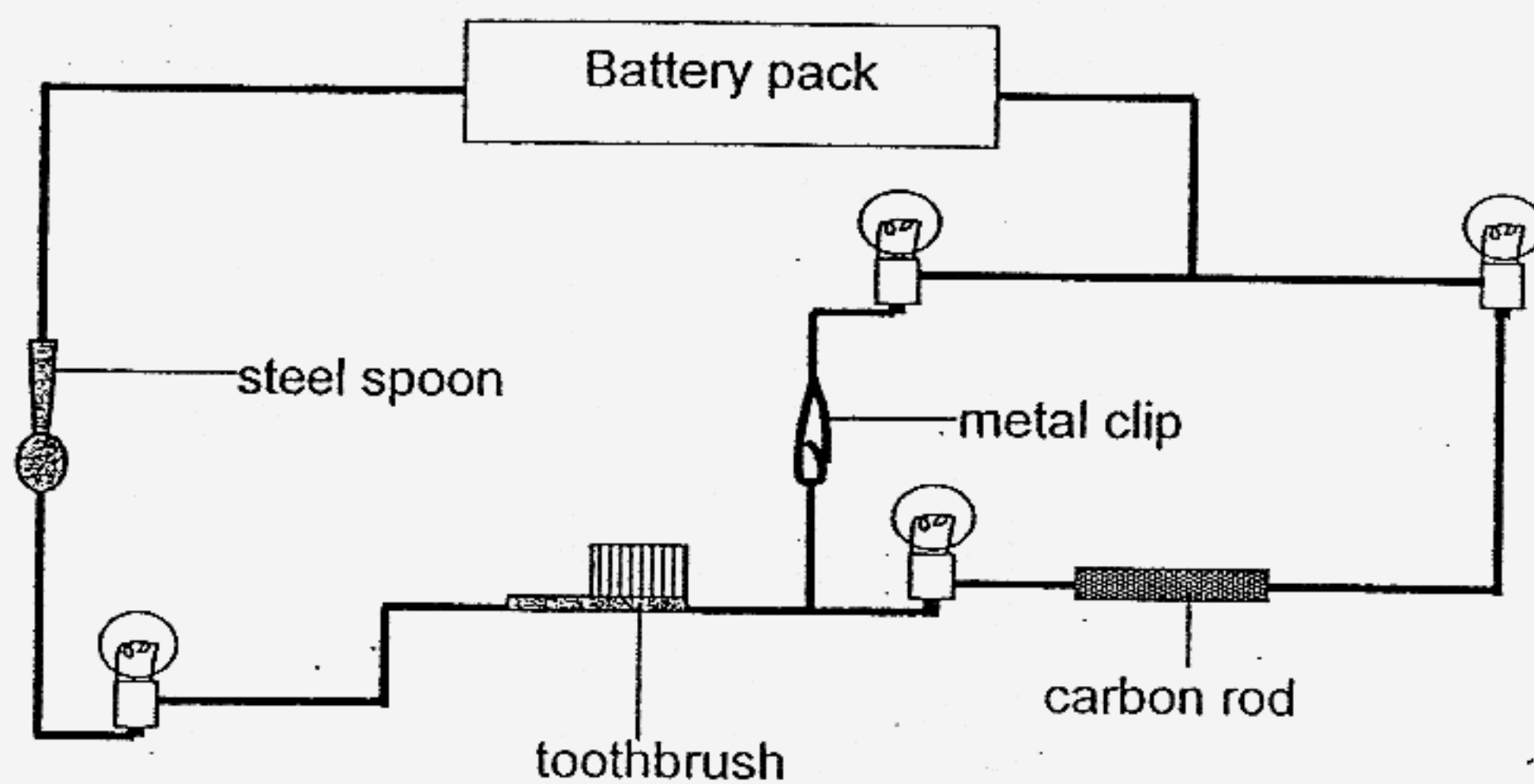

Circuit 1

- (a) How many bulb(s) will light up ? (1 mark)

- (b) In Circuit 2 shown below, the positions of the metal clip, toothbrush and carbon rod are rearranged. Write in the boxes provided "metal clip", "toothbrush", and "carbon rod" such that the most number of bulbs could be lit. (1 mark)

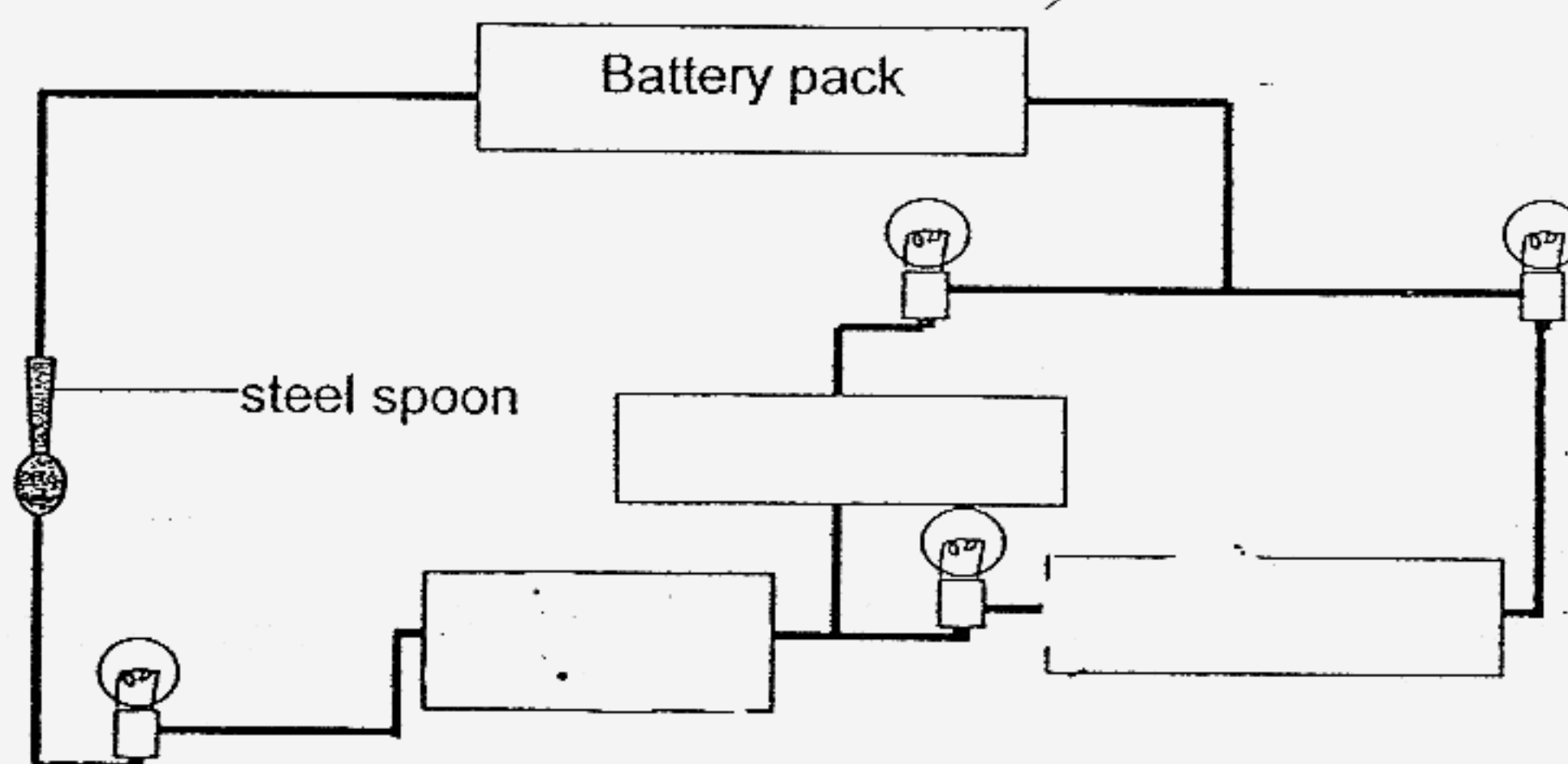

Circuit 2

- 46 The set-up below was used to study how fast a heating element F could heat up a beaker of water. When the circuit was closed, the temperature of the water was taken at regular time interval and recorded.

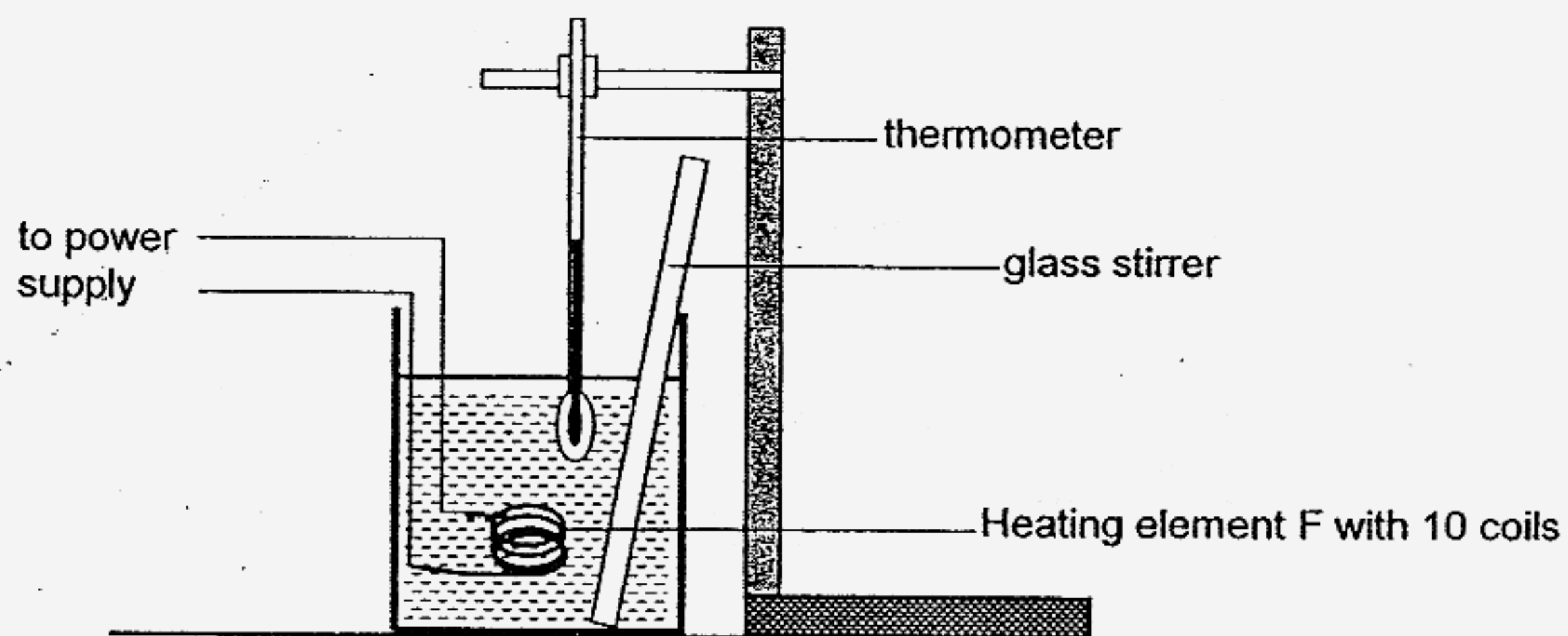

- (a) Explain why the water had to be stirred well before its temperature was taken. (1 mark)

After several readings were taken, the graph below was plotted.

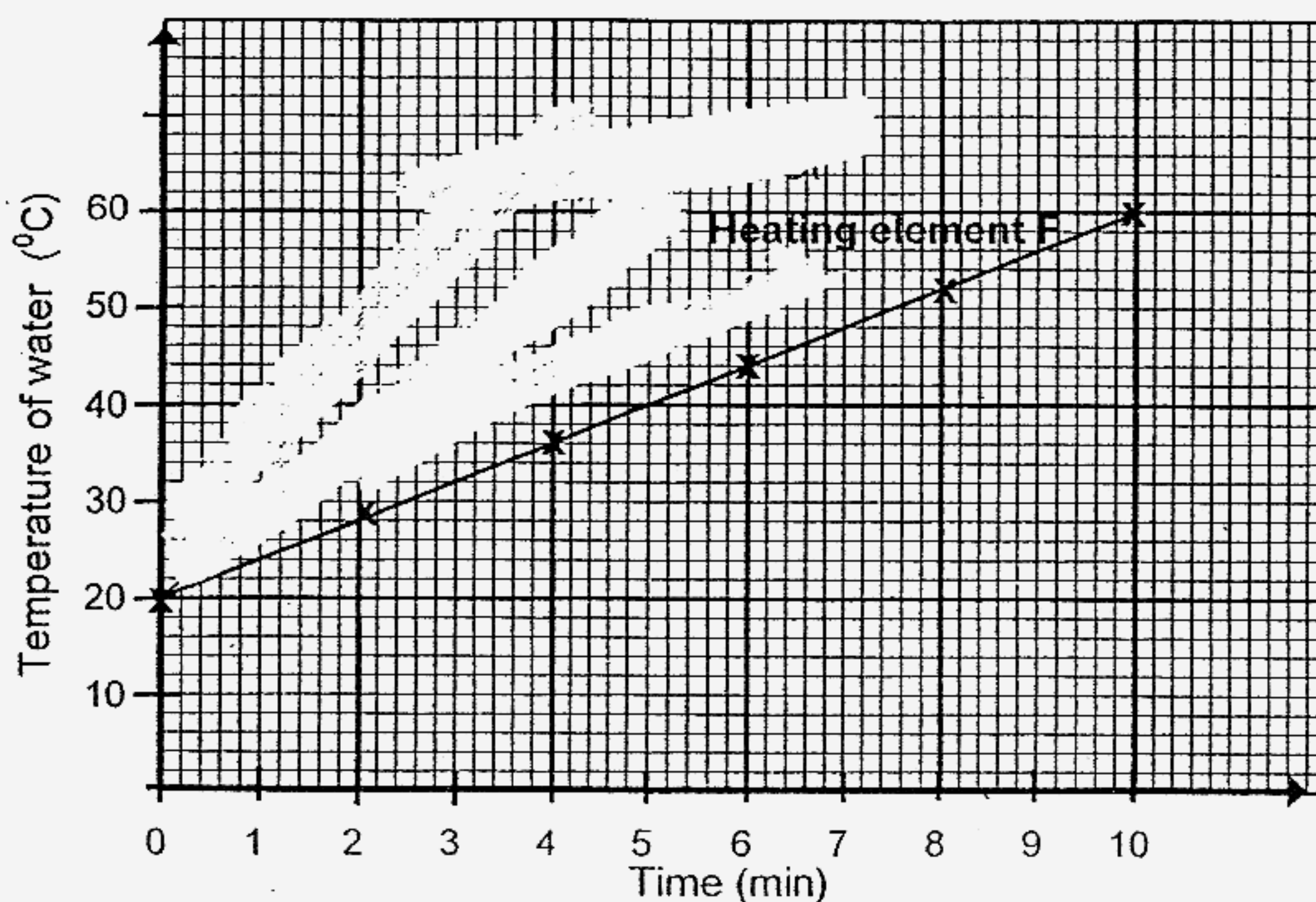

The experiment was repeated using the same set-up. The amount of water and its starting temperature were kept the same. A heating element G, made of the same material as F, was used. G had 20 coils. The last reading was taken when the water was 60°C .

- (b) On the same axes of the graph above, draw a new graph to show the change in temperature of the water with time for the heating element G.

(2 marks)

-----END OF PAPER-----

Setters: Mr Pang Kia Keng
Ms Yasmeen Mohamad

SECTION A : (60 MARKS)

Qn no.	Ans
1	3
2	1
3	1
4	2
5	4
6	3
7	3
8	2
9	4
10	3

Qn no.	Ans
11	2
12	4
13	2
14	4
15	4
16	4
17	3
18	1
19	1
20	4

Qn no.	Ans
21	3
22	4
23	2
24	3
25	1
26	4
27	2
28	1
29	1
30	1

SECTION B (40 MARKS)

Qn No.	Answers
31a	To act as a control to show that liquid prevented the fish from laying eggs.
31b	The injection has shocked the fishes

32a	Plant Y : Wind Plant Z : Animals
32b (i)	Coconut
(ii)	Fibrous husk that traps air

33 (i)	U
33 (ii)	U
(iii)	S
(iv)	S

34a	The cell wall
34b	The presence of chloroplast

Qn No.	Answers
35 (i)	Not possible to tell
(ii)	False
(iii)	True
(iv)	False

36 (i)	There was not enough sunlight for plant E to make food due to the wide crown of A and C
(ii)	B and D has shallow roots so they do not have enough nutrients that is taken in by A (which have deep roots)

37a (i)	The fishes may die.
(ii)	Plant C would block off sunlight from reaching plant B. So plant B cannot make food and would die. So the fishes do not have enough food and would starve to death.
37b	The fishes in the pond would start to die as they do not have enough oxygen food and space to survive.

38 (i)	Birds A and E
(ii)	Bird C
(iii)	Bird C has a long beak, making it able to feed on the nectar of the flower.
(iv)	It does not have feathers on his head, so heat would be lost easily to the surroundings and would freeze to death.

39a	When the sand was shaken, there is friction so heat is produce making the temperature of the sand higher.
39b	The tin can is made of metal and it is better conductor of heat than the plastic can, so heat would be conducted away from the tin can faster than the plastic can.

40	Advantage : Wind is a renewable resource.
	Disadvantage : There may be no wind sometime so electricity would be generated at a slower rate.

41	Ball A traveled faster as it does not have a bump in the track like ball B. So Ball A would have some kinetic energy than Ball B as some of Ball B kinetic energy would be converted into potential energy when it goes up the bump, therefore it would be at a slower speed than Ball A.
-----------	--

Qn No.	Answers
42a	Drop of alcohol : Heat gained Skin : heat loss
42b	The Ether would evaporate away quickly, taking heat from the water with it so the temperature of the water would decrease,

43a	Gravitational potential energy \longrightarrow kinetic energy \longrightarrow electric energy
43b	Wheel and axle
43c	With a bigger wheel, effort to move load at axle decreases, turbine spin faster producing more electricity.

44a	When the water flows out, the gas produced by the lit mosquito coil rushes through the tube and occupying the space.
44b	The limewater would turn chalky.

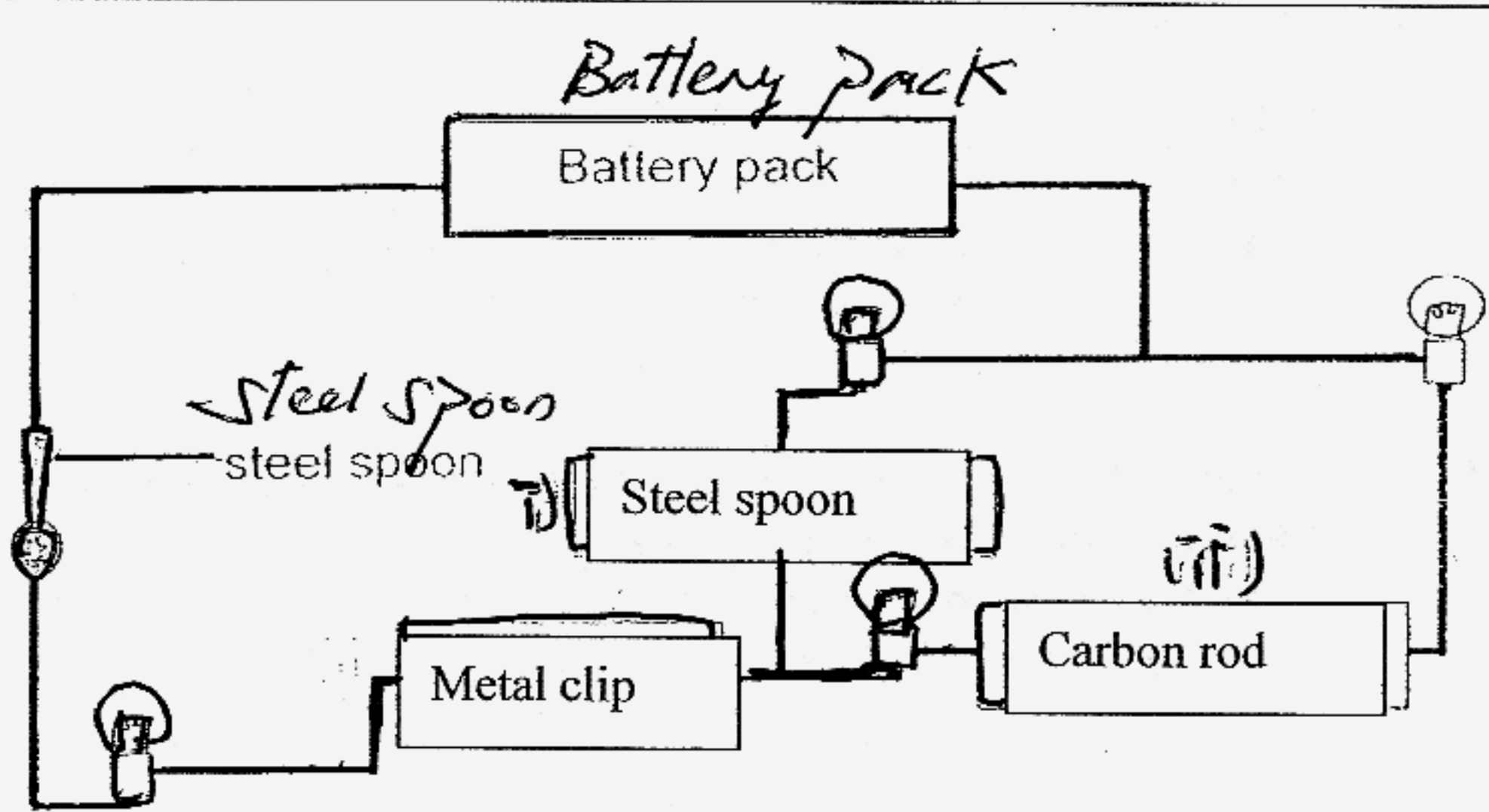
45a	None of the bulbs would light up.
45b	 <p style="text-align: center;">Circuit 2</p>

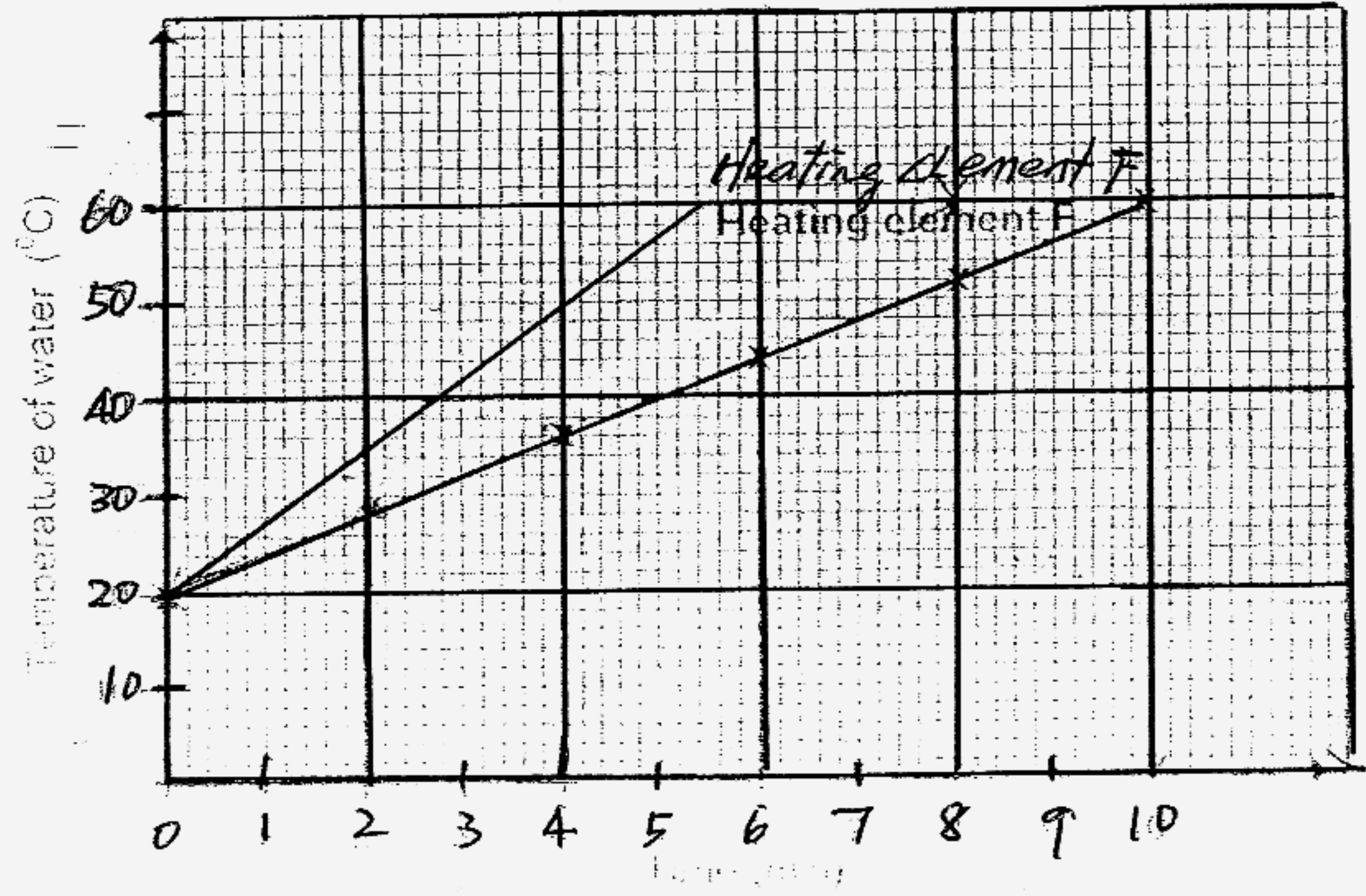
Qn No.	Answers																					
46a	Heat travels from hotter to cooler places so the water had to be stirred well so that there would be an accurate reading.																					
46b	 <p>The graph plots Temperature of water (°C) on the y-axis against Time (min) on the x-axis. Two lines represent different heating elements, both starting at 20°C at time 0.</p> <table><tr><th>Time (min)</th><th>Temperature (°C) - Heating element F</th><th>Temperature (°C) - Heating element E</th></tr><tr><td>0</td><td>20</td><td>20</td></tr><tr><td>2</td><td>35</td><td>28</td></tr><tr><td>4</td><td>50</td><td>36</td></tr><tr><td>6</td><td>60</td><td>44</td></tr><tr><td>8</td><td>-</td><td>52</td></tr><tr><td>10</td><td>-</td><td>60</td></tr></table>	Time (min)	Temperature (°C) - Heating element F	Temperature (°C) - Heating element E	0	20	20	2	35	28	4	50	36	6	60	44	8	-	52	10	-	60
Time (min)	Temperature (°C) - Heating element F	Temperature (°C) - Heating element E																				
0	20	20																				
2	35	28																				
4	50	36																				
6	60	44																				
8	-	52																				
10	-	60																				