

Index Number :

--	--	--	--	--	--

CHIJ ST NICHOLAS GIRLS' SCHOOL



Primary 6
Preliminary Examination II – 2006
SCIENCE
BOOKLET A

14 SEPTEMBER 2006

Name : _____ ()

Class : Primary 6 _____

Total Time for Booklets A and B: 1 hour 45 minutes

30 questions
60 marks

Do not open this booklet until you are told to do so.
Follow all instructions carefully.
Answer all questions.

Section A (30 x 2 = 60 MARKS)

For each question from 1 to 30, four options are given. One of them is the correct answer. Make your choice (1, 2, 3 or 4). **Shade the correct oval (1, 2, 3 or 4) on the Optical Answer Sheet.**

1. Which of the following are functions of the skeleton?
- A It protects our stomach.
 - B It gives our body its shape.
 - C It protects important organs inside the body from injury.
 - D It allows the muscles to attach themselves to enable the body to move.
- (1) B and C only
(2) A and D only
(3) B, C and D only
(4) A, B, C and D only

2. Study the diagram below.

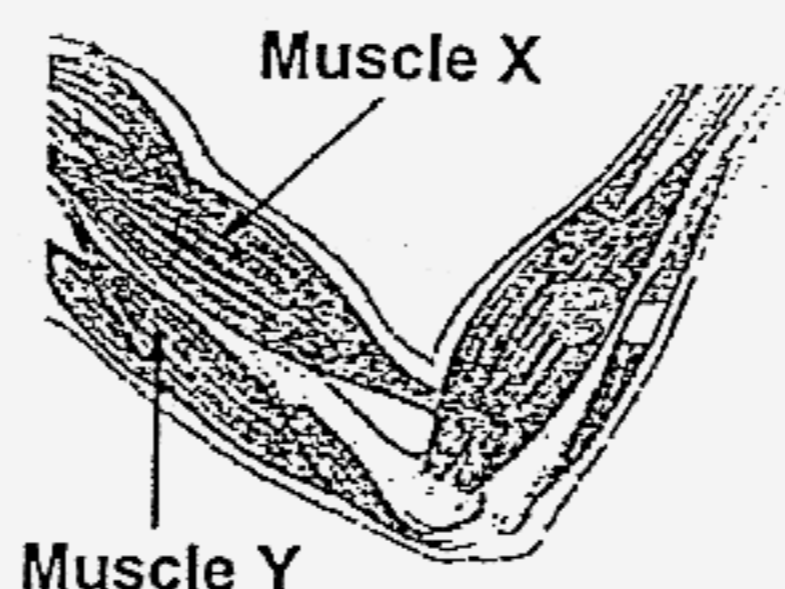

Which one of the following sets of muscle action would allow the arm to be lowered?

	Muscle X	Muscle Y
(1)	relaxes	contracts
(2)	relaxes	relaxes
(3)	contracts	relaxes
(4)	contracts	contracts

3. John placed some elodea plant in a conical flask filled with water before placing the setup outdoors as shown below.

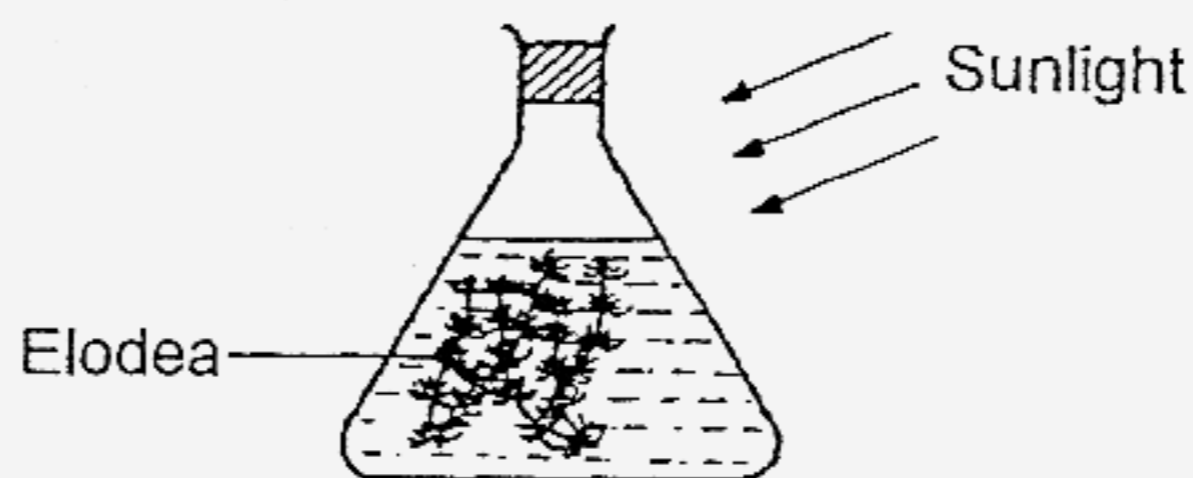

Which of the following statements are true about the experiment?

- A Simple sugar is made.
- B The water level will fall by half.
- C Bubbles can be seen on the elodea.
- D The rate of production of bubbles is constant throughout the day.

- (1) A and C only
- (2) A and B only
- (3) B and C only
- (4) C and D only

4. Mike conducted a fair test using similar string bean seedlings over 2 weeks. He tabulated the results in the table below.

Pot	Type of soil	No. of times string bean seedlings are watered each day	No. of string bean seedlings in each pot	Average height of string bean seedlings in each pot (cm)
A	Sandy	3	5	8.9
B	Loamy	3	10	7.7
C	Sandy	3	10	6.0
D	Loamy	3	5	10.8

Which of the following are possible aims for Mike's experiment?

- A To find out if overcrowding affects the growth of the seedlings.
- B To find out if the size of pot used affects the growth of the seedlings.
- C To find out if the type of soil used affects the growth of the seedlings.
- D To find out if the amount of water used affects the growth of the seedlings.

- (1) A and D only
- (3) C and D only
- (2) B and C only
- (4) A and C only

5. The flowchart shows some parts of body system/s. P and Q are substances found in the blood taken from the small intestine.

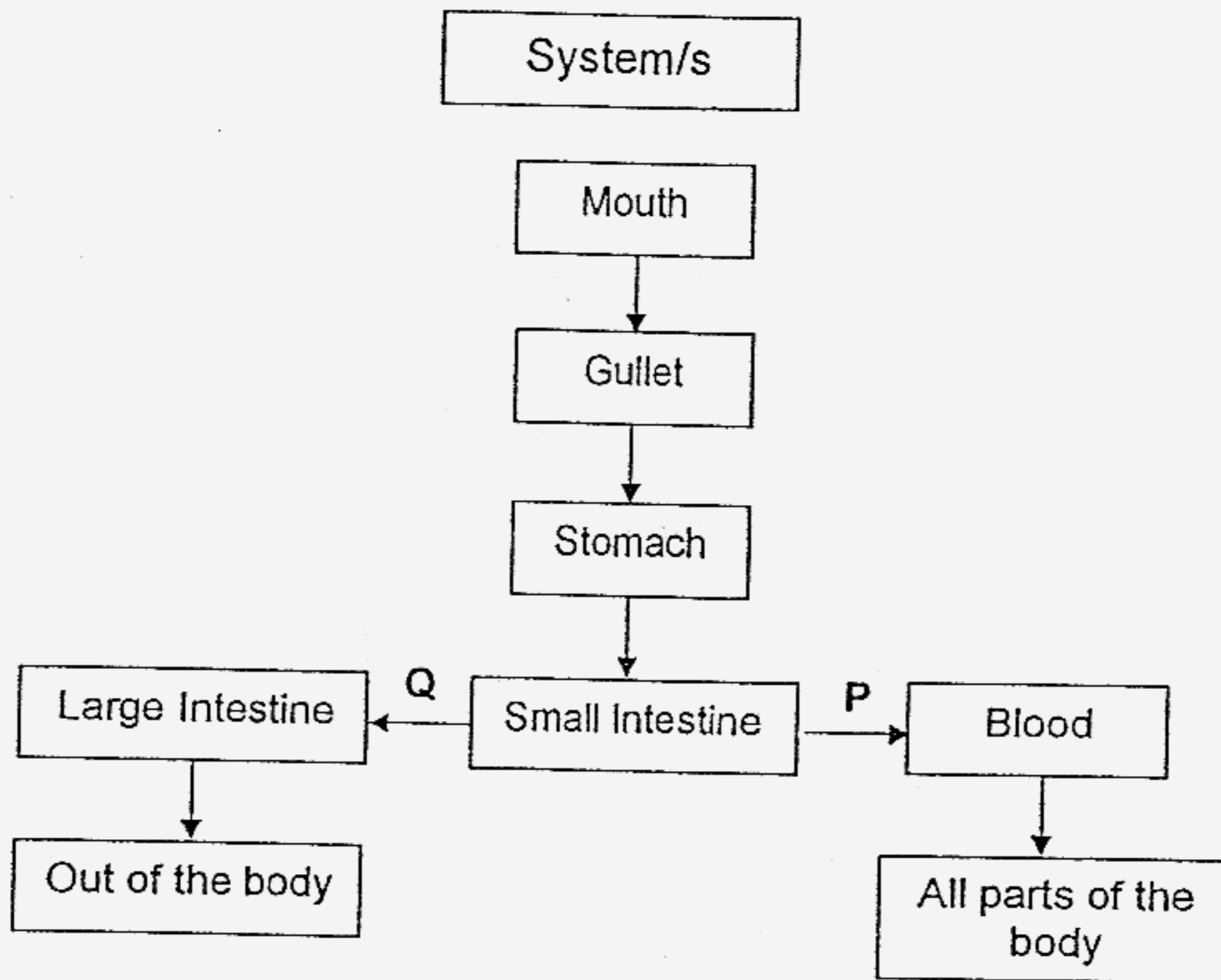

What do ~~X~~, P and Q represent?

	System/s	P	Q
(1)	Digestive System	Digested food	Carbon dioxide
(2)	Circulatory System	Oxygen	Carbon dioxide
(3)	Digestive & Circulatory System	Digested food	Undigested food
(4)	Respiratory & Digestive System	Digested food	Carbon dioxide

6. What are the common cell parts that you can find from the stem of a cactus plant and a cell from the underground stem of a ginger plant?

- (1) cell wall and chloroplast
- (2) chloroplast and cell membrane
- (3) cell wall and cell membrane
- (4) cell wall, chloroplast and cell membrane

7. The chart below classifies some plants into 5 groups based on their methods of reproduction.

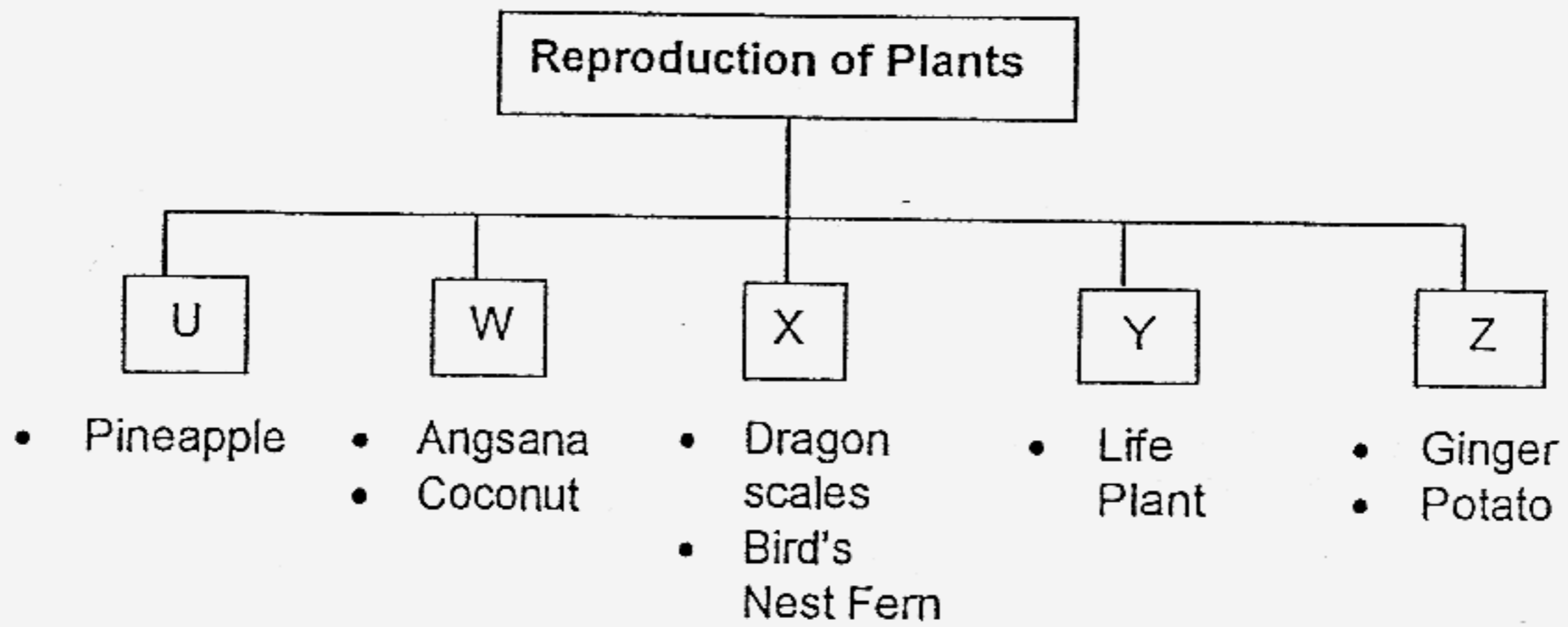

Which one of the following correctly matches the method of reproduction and the plants mentioned?

	U	W	X	Y	Z
(1)	Suckers	Fruit	Seeds	Leaves	Roots
(2)	Leaves	Seeds	Spores	Roots	Stems
(3)	Roots	Fruits	Seeds	Stems	Roots
(4)	Suckers	Seeds	Spores	Leaves	Stems

8. Which of the following are reasons why Man uses biotechnology to genetically modify some crops?

- A The harvested products stay fresh longer.
- B The crops grow faster and produce better yield.
- C The crops are more resistant to diseases and pests.
- D The harvested products are better in nutritional value.

- (1) A and B only
- (2) C and D only
- (3) A, B and C only
- (4) All of the above

9. Study the classification chart below.

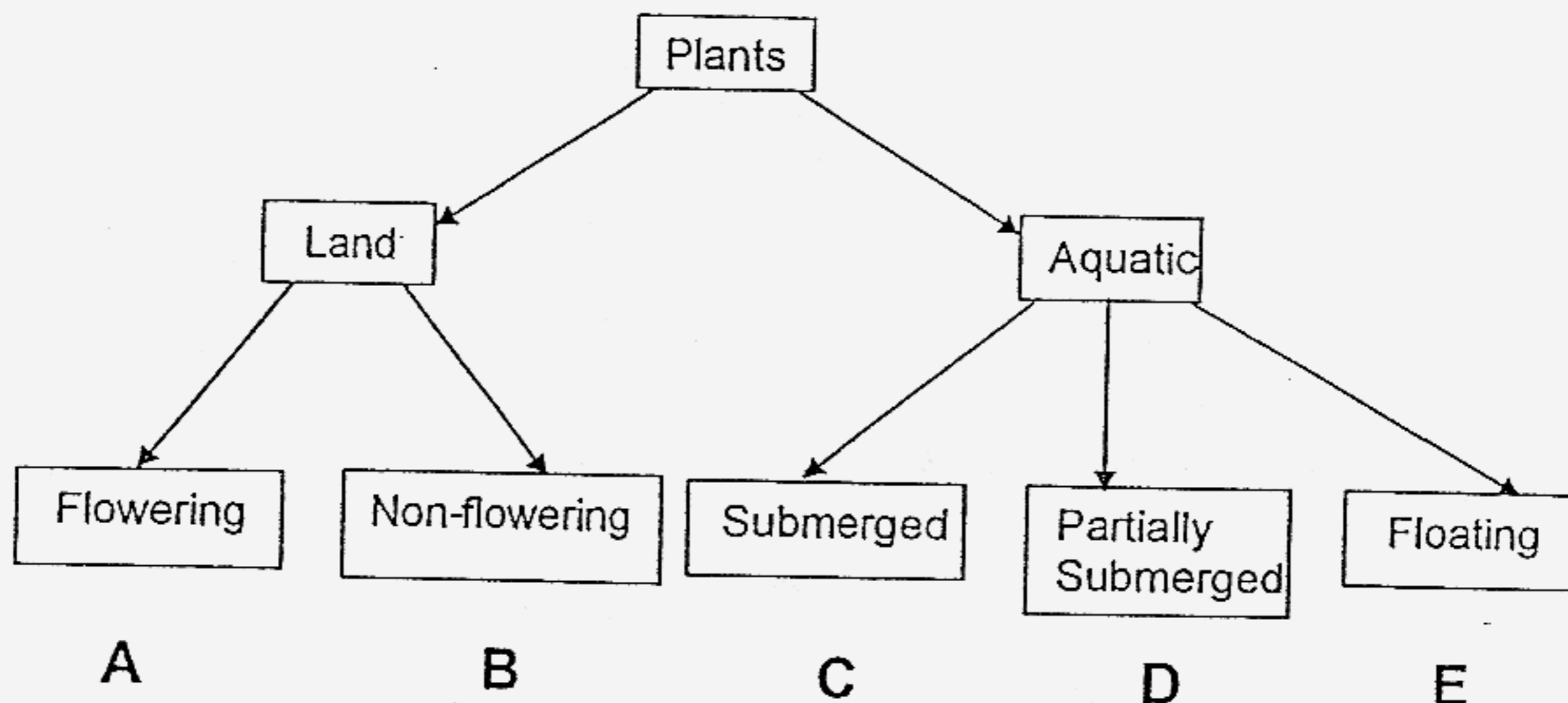

Which one of the following is correctly classified?

	A	B	C	D	E
(1)	Orchid	Dumbcane	Cabomba	Water Lettuce	Arrowhead
(2)	Pong Pong	Ladder fern	Water Lily	Cattail	Mosquito Fern
(3)	Cactus	Moss	Water Shamrock	Hibiscus	Water Hyacinth
(4)	Jasmine	Bird's Nest Fern	Hydrilla	Lotus	Duckweed

10. Insecticides and weedkillers are used to kill insects and weeds. However, excessive use of these chemicals will _____.

- (1) lead to air pollution
- (2) cause the crops to grow better
- (3) increase the population of useful organisms
- (4) upset the balance of the food relationship among organisms

11. The pie chart below shows the 4 living things, A, B, C and D in a habitat.

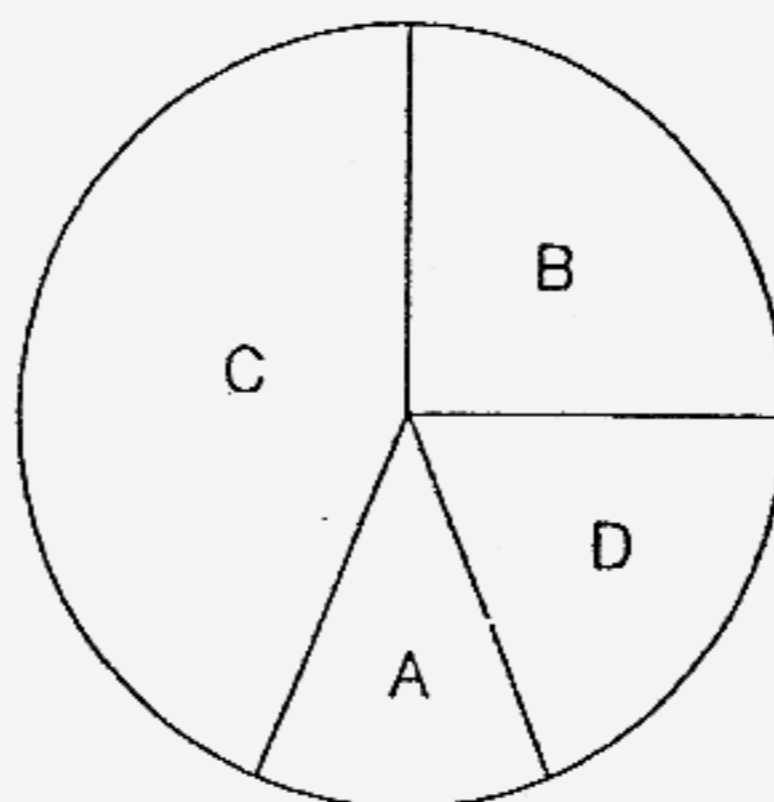

Based on the piechart, 4 pupils, Moira, Tiffy, Becca and Fionna, made the following statements:

Moira: C is likely to be a food producer.

Tiffy: The food chain is likely to be $C \rightarrow B \rightarrow D \rightarrow A$.

Becca: D is purely carnivorous.

Fionna: Energy is lost throughout the food chain in the form of heat and waste materials.

Who made the correct statement?

- (1) Moira and Tiffy
- (2) Tiffy and Becca
- (3) Moira, Tiffy and Fionna
- (4) All of the girls

12. The diagram below shows the beaks belonging to that of 4 birds, A, B, C and D.



Bird A



Bird B



Bird C



Bird D

Which one of the following is correctly matched to the likely diet of the 4 birds?

	A	B	C	D
(1)	fish	nectar	mice	seeds
(2)	insects	berries	fish	mice
(3)	nectar	insects	mice	fish
(4)	fish	seeds	mice	nectar

13. Which of the following are harmful effects of deforestation?

- (1) It will cause the formation of acid rain.
- (2) It will cause an increase in the greenhouse gas.
- (3) It will lead to the depletion of ozone layer in the atmosphere.
- (4) More spaces will be made available for construction of buildings.

14. A group of scientists counted the plants and animals found in a pond. Their observation is presented in the graph below.

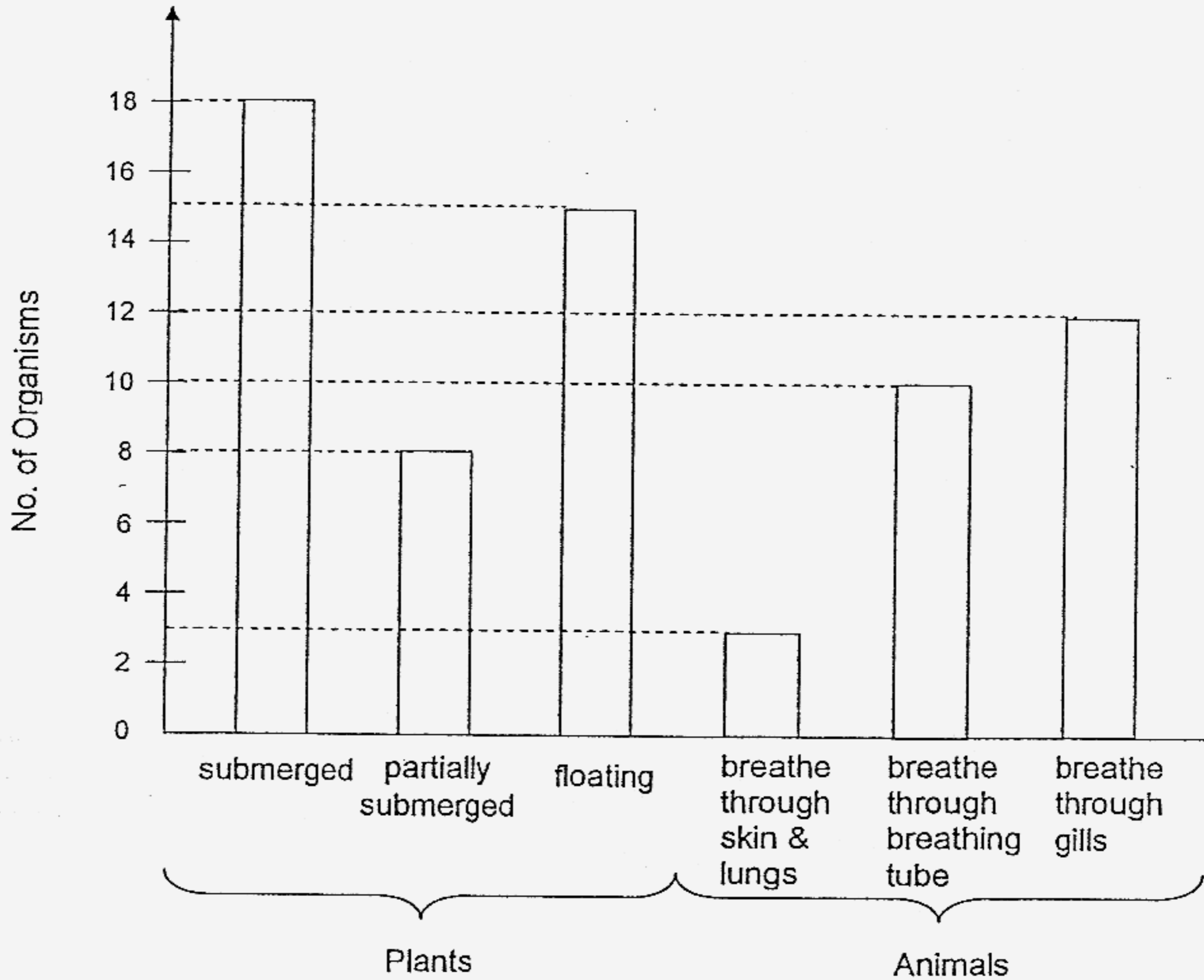

Which of the following statements are correct?

- A There is only one pond community.
- B There are 25 populations of animals.
- C There are 8 water lettuces in the pond.
- D There are at least 6 populations of plants and animals.

- (1) A and D only
- (2) B and C only
- (3) A, B and D only
- (4) All of the above

15. Study the food chain below carefully.



Which one of the following graphs shows the likely changes in the populations of the grass, grasshopper and the eagle if there is a sudden decrease in the sparrow population?

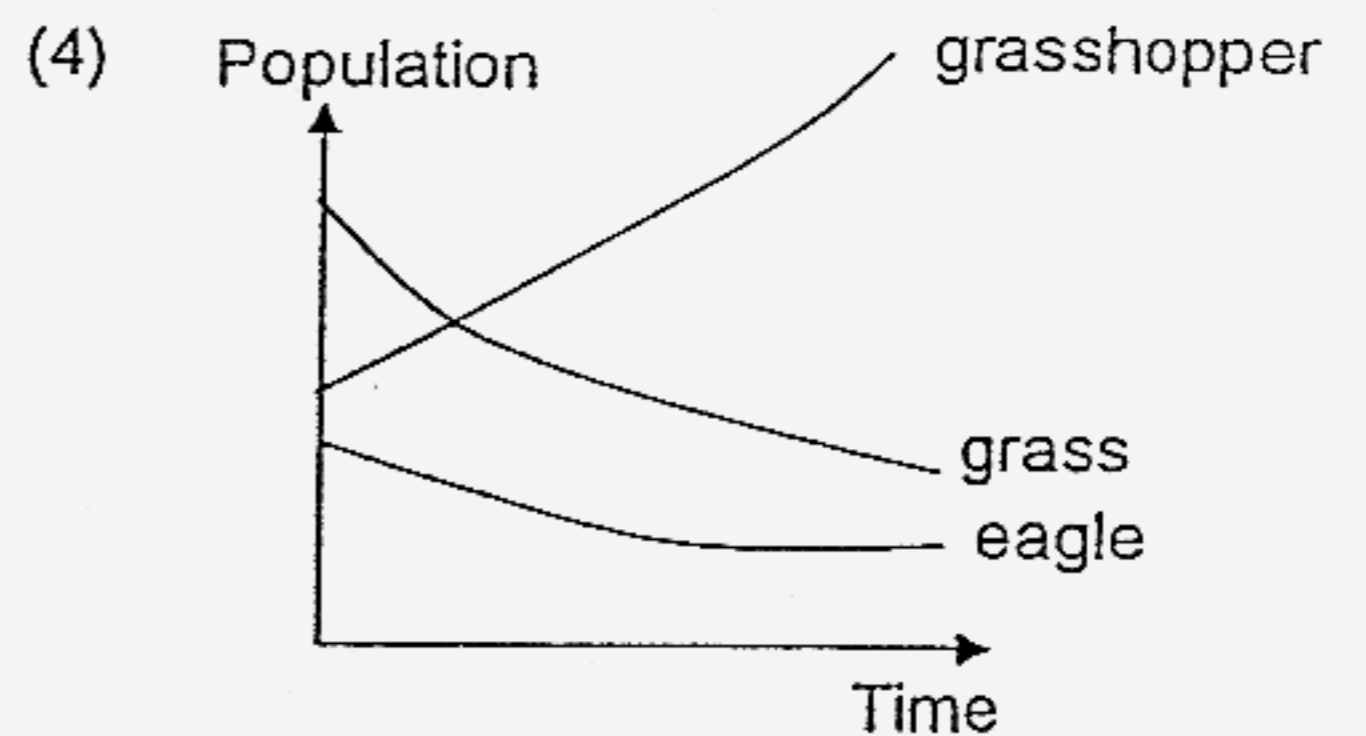
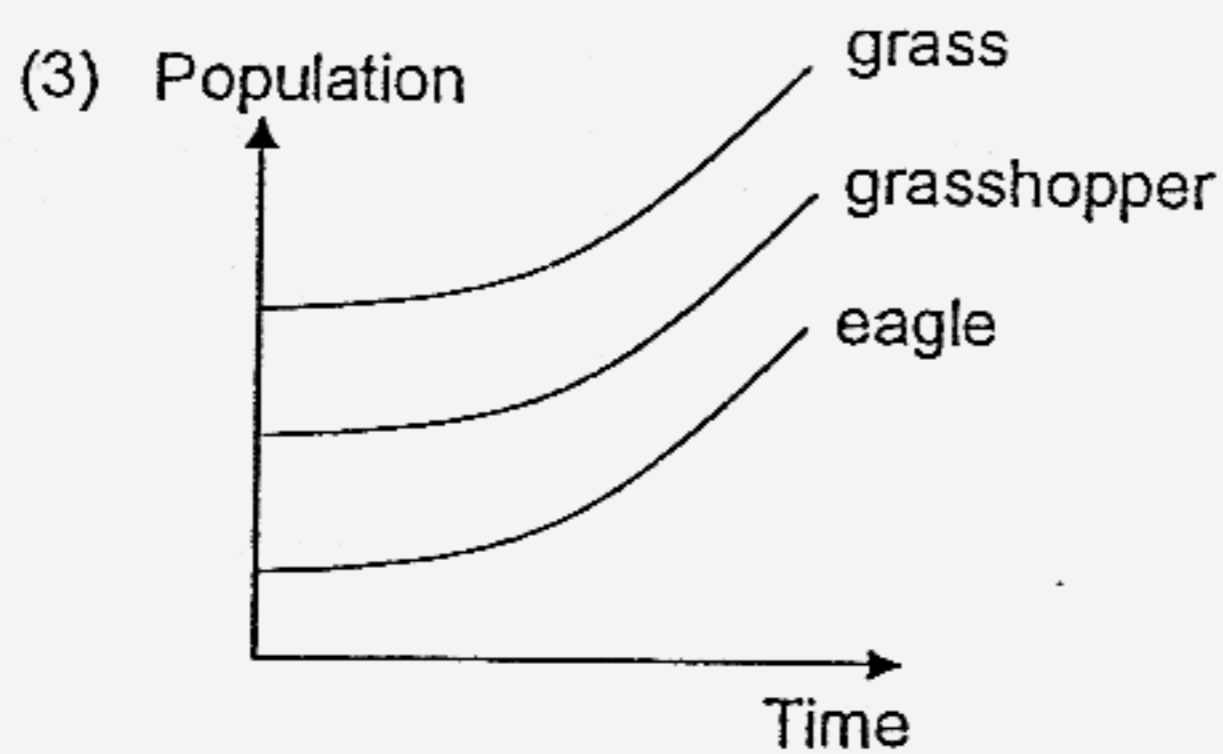
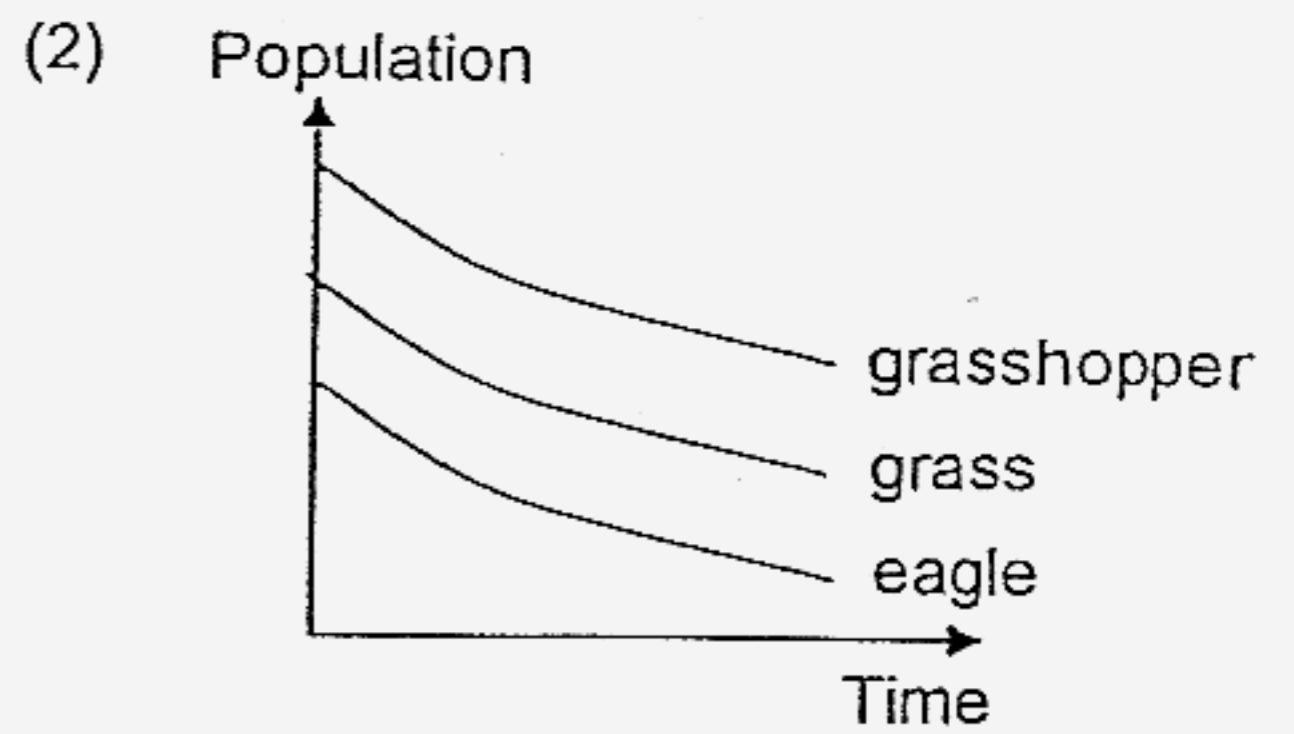
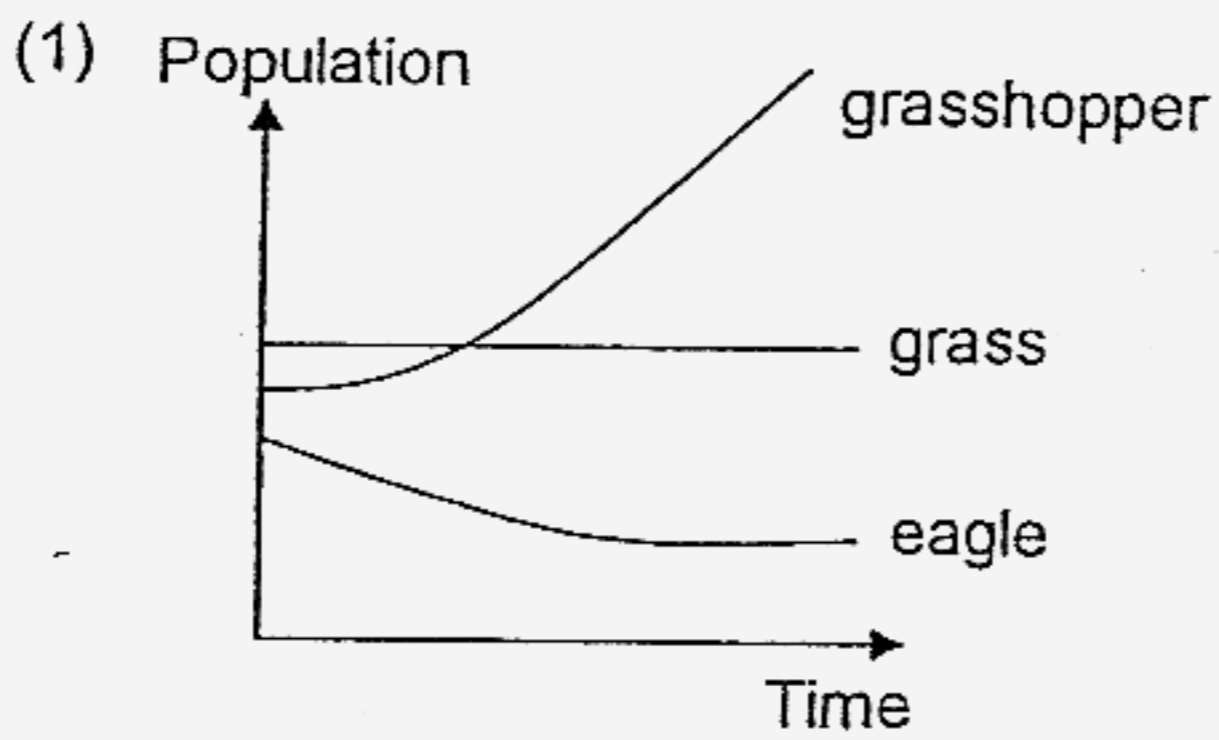

16. Which one of the following food is not a product of fermentation?

- (1) Cheese
- (2) Yoghurt
- (3) Vinegar
- (4) Soya beans

17. The diagram below shows the position of the compass needle when it was placed on a table.

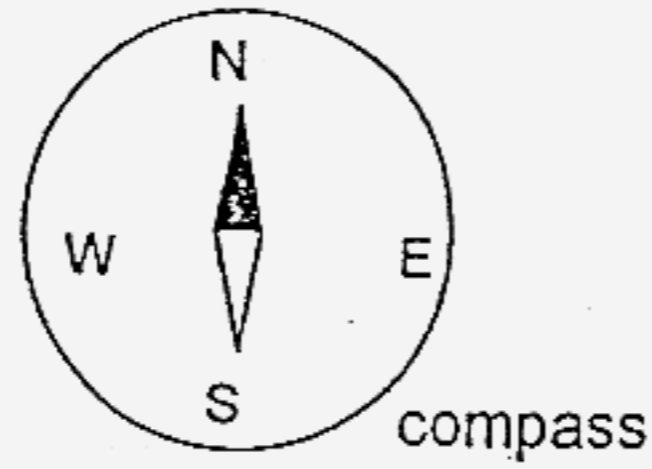

The diagram below shows what happened when it was placed near two metal bars, X and Y.

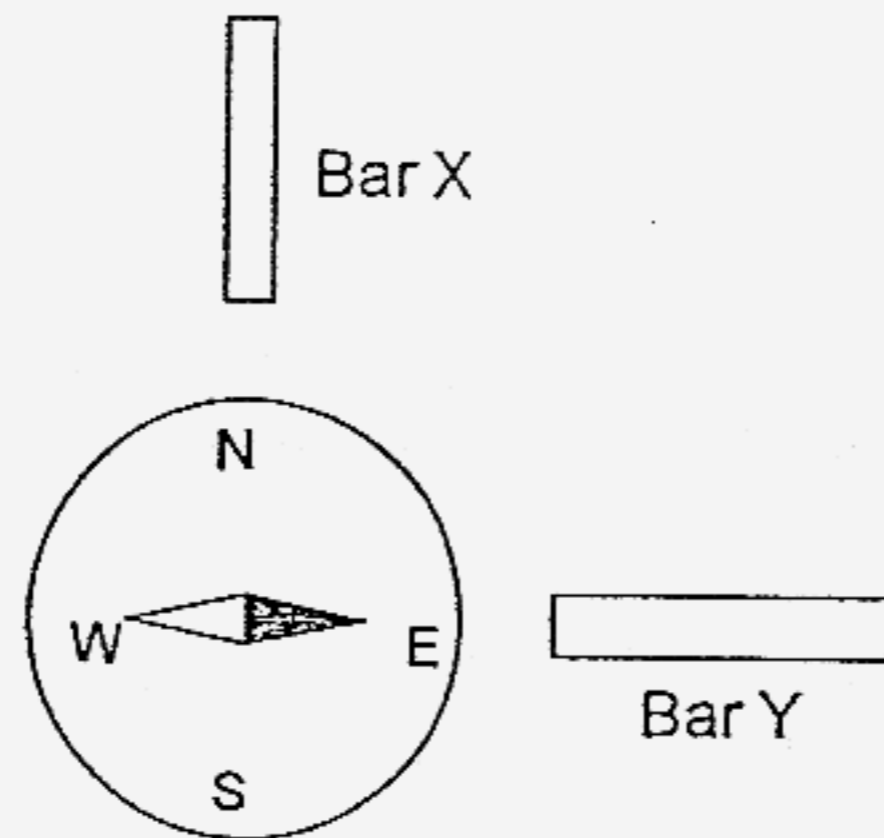

Which one of the following statements about the two metal bars is definitely correct?

- (1) Bar Y is a magnetic substance.
- (2) Both metal bars are magnetic substances.
- (3) Bar X is a magnet with its south pole facing the compass.
- (4) Bar Y is a magnet with its north pole facing the compass.

18. Fandi set up the experiment as shown in the diagram below.

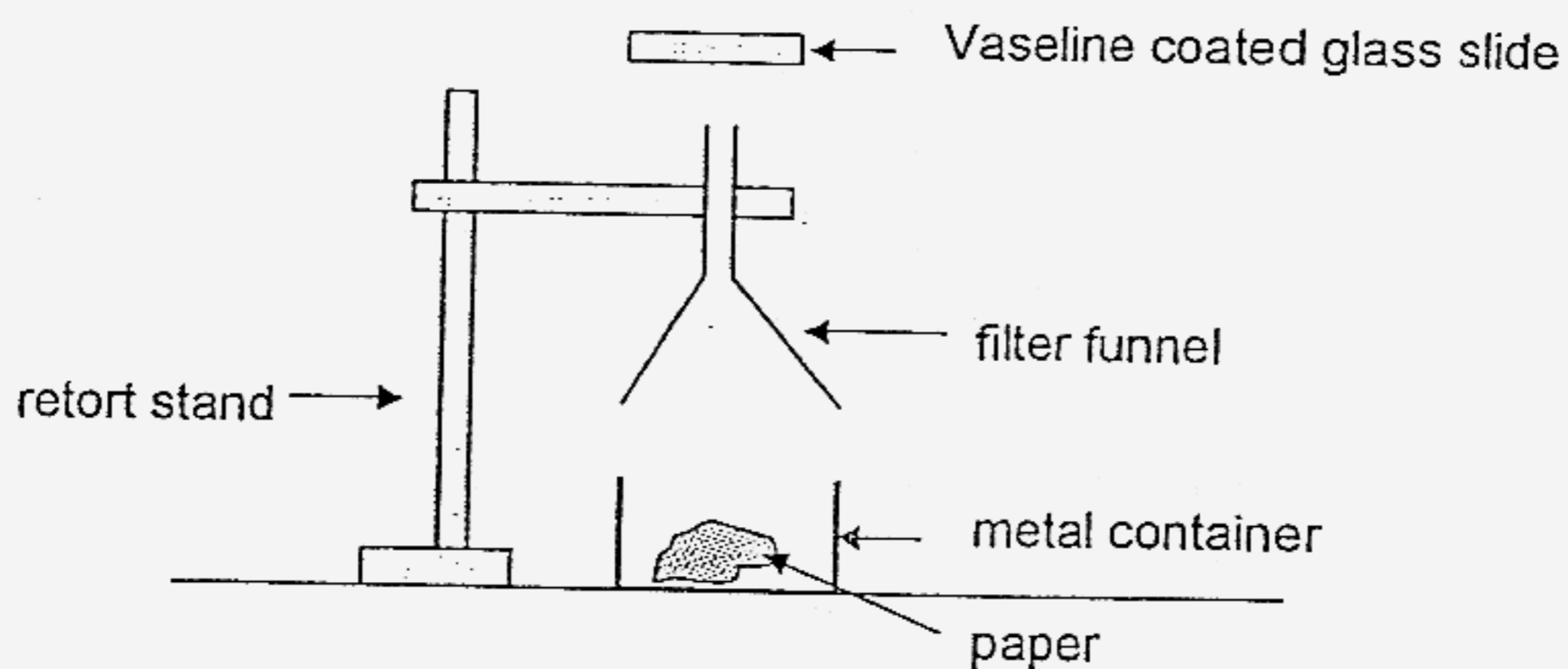

He did the following things:

- (i) He put a piece of paper inside the metal container.
- (ii) He added a few drops of oil to the paper.
- (iii) He lit the paper.

He then changed another Vaseline coated glass and repeated steps (i) to (iii) above using charcoal, rubber and wood.

What was he trying to find out?

- (1) To classify fuels into solid, liquid and gas.
- (2) To collect the gases produced during burning of fuels.
- (3) To see which substance takes the shortest time to burn.
- (4) To show that burning of these substances can cause pollution.

19. Three objects A, B and C were lifted up by using three pulley systems as shown in the diagrams below. The efforts needed for all three systems were the same.

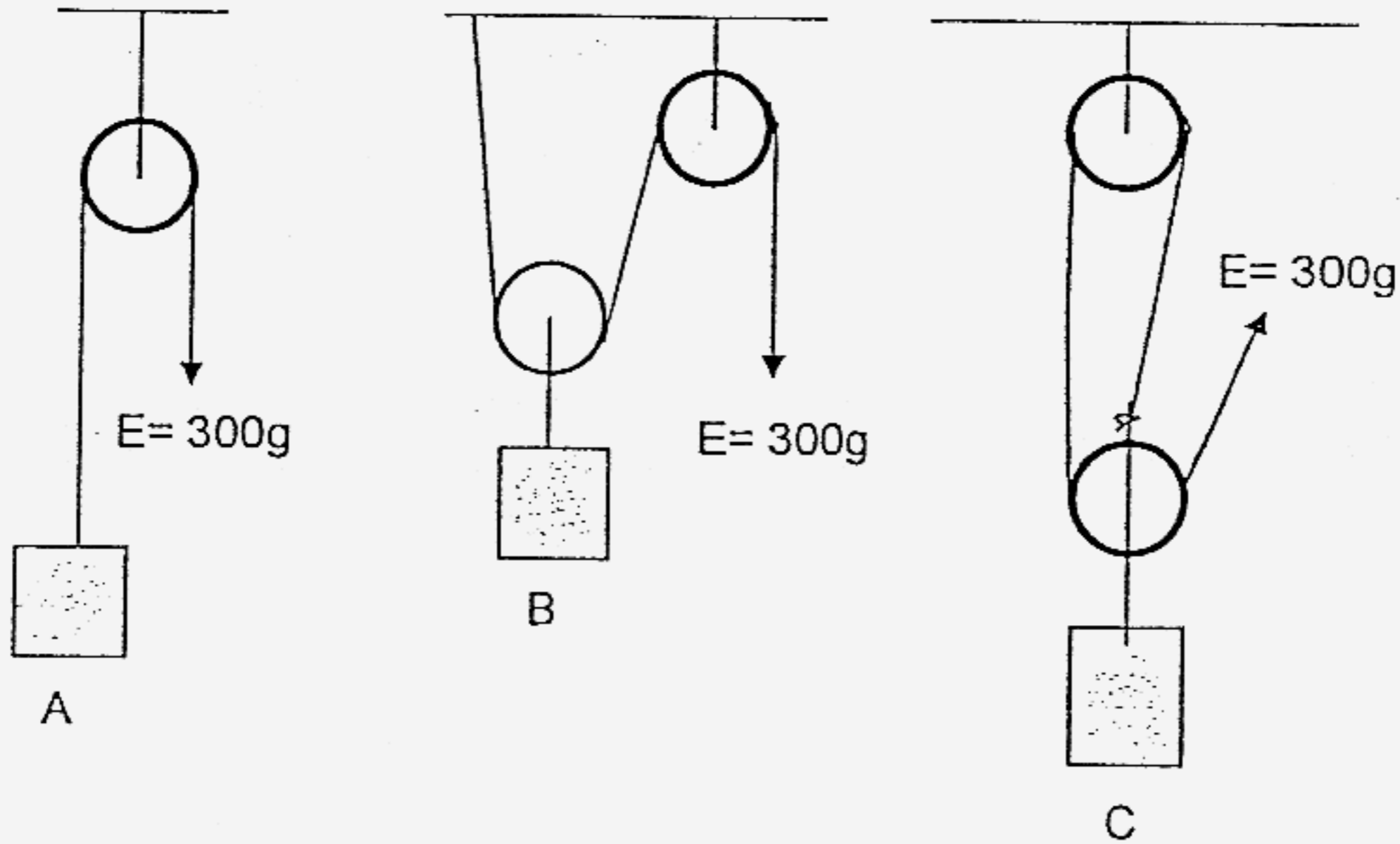

Which one of the following lists shows the load of pulley systems A, B and C respectively?

	Load		
	A	B	C
(1)	300g	300g	300g
(2)	600g	150g	100g
(3)	300g	600g	900g
(4)	310g	150g	100g

20. One dark night, Lilian walked from point X to point Z passing a lamp post at Y.

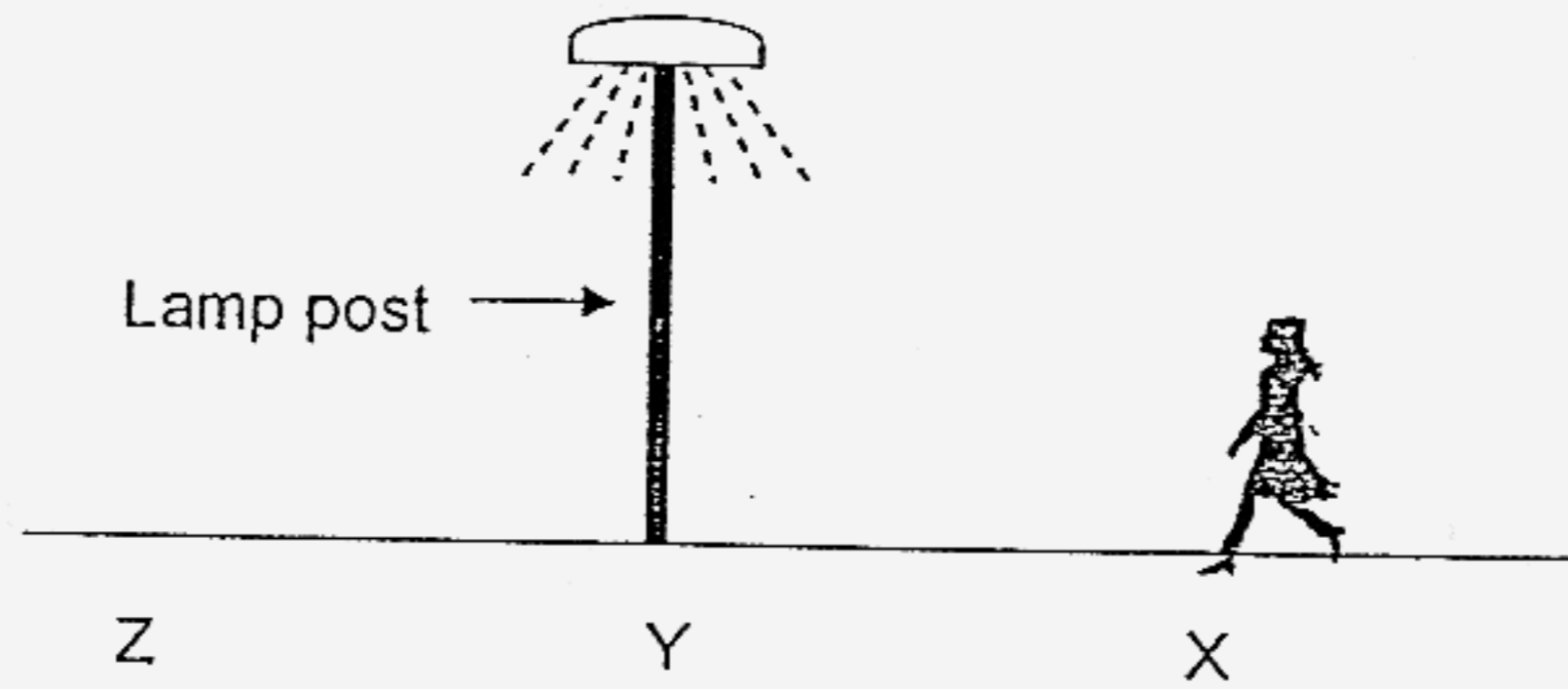

If the only light source nearby was the lamp post, which one of the graphs below shows how the length of her shadow changes from X to Z?

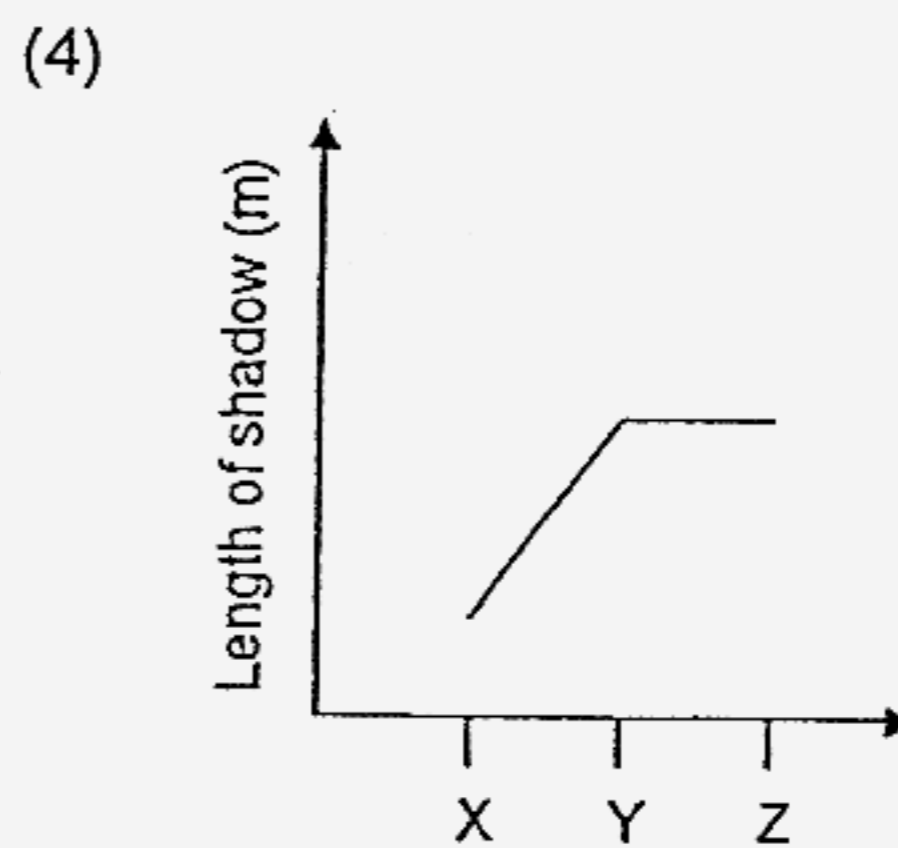
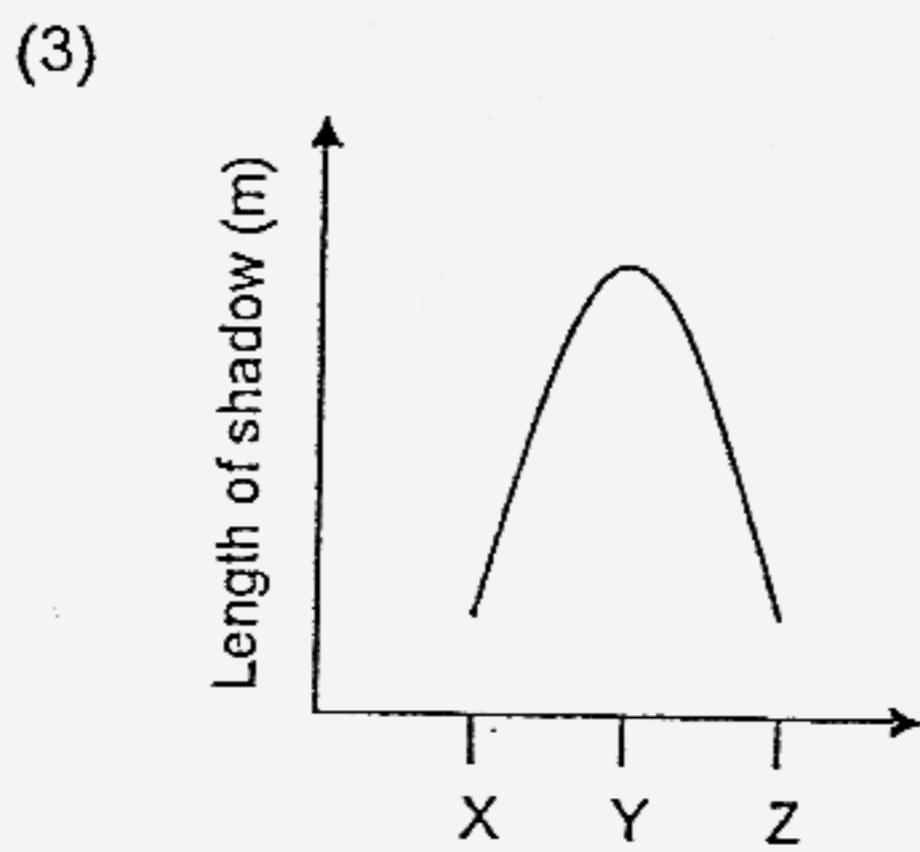
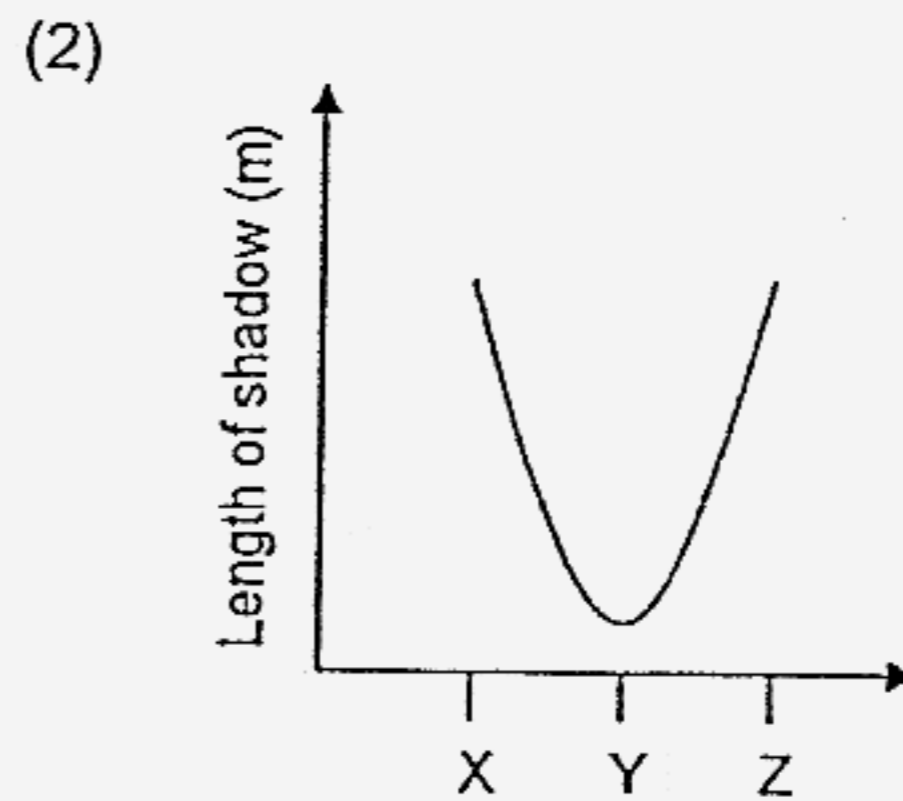
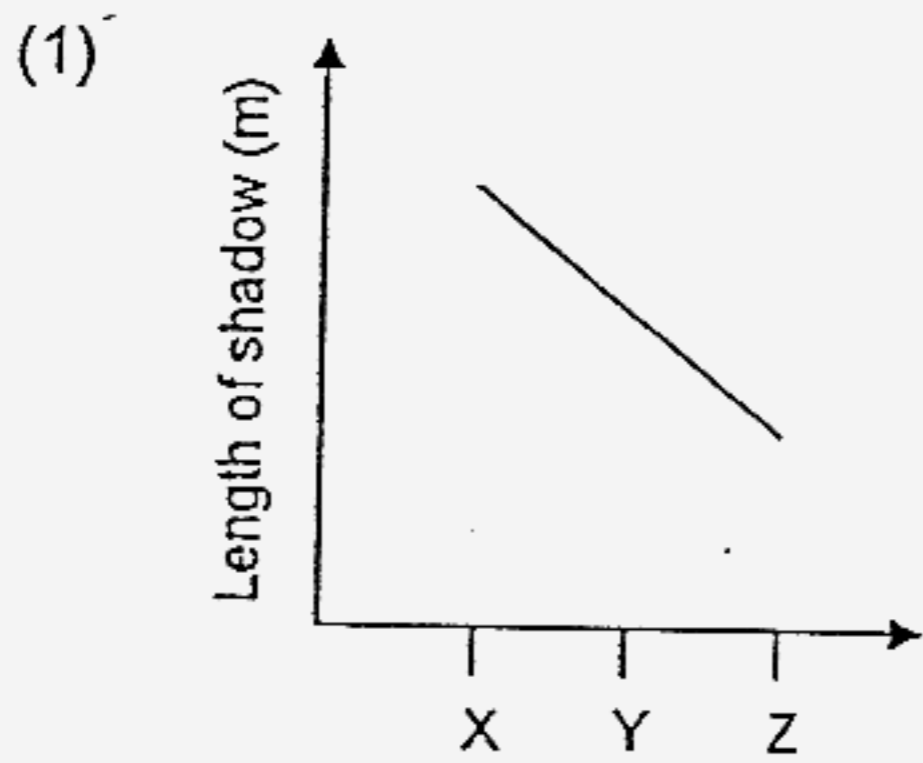

21. The hardness of a mineral is measured by how easy it is to scratch. Hardness is shown on a scale from 0 to 10, with 10 being the hardest.

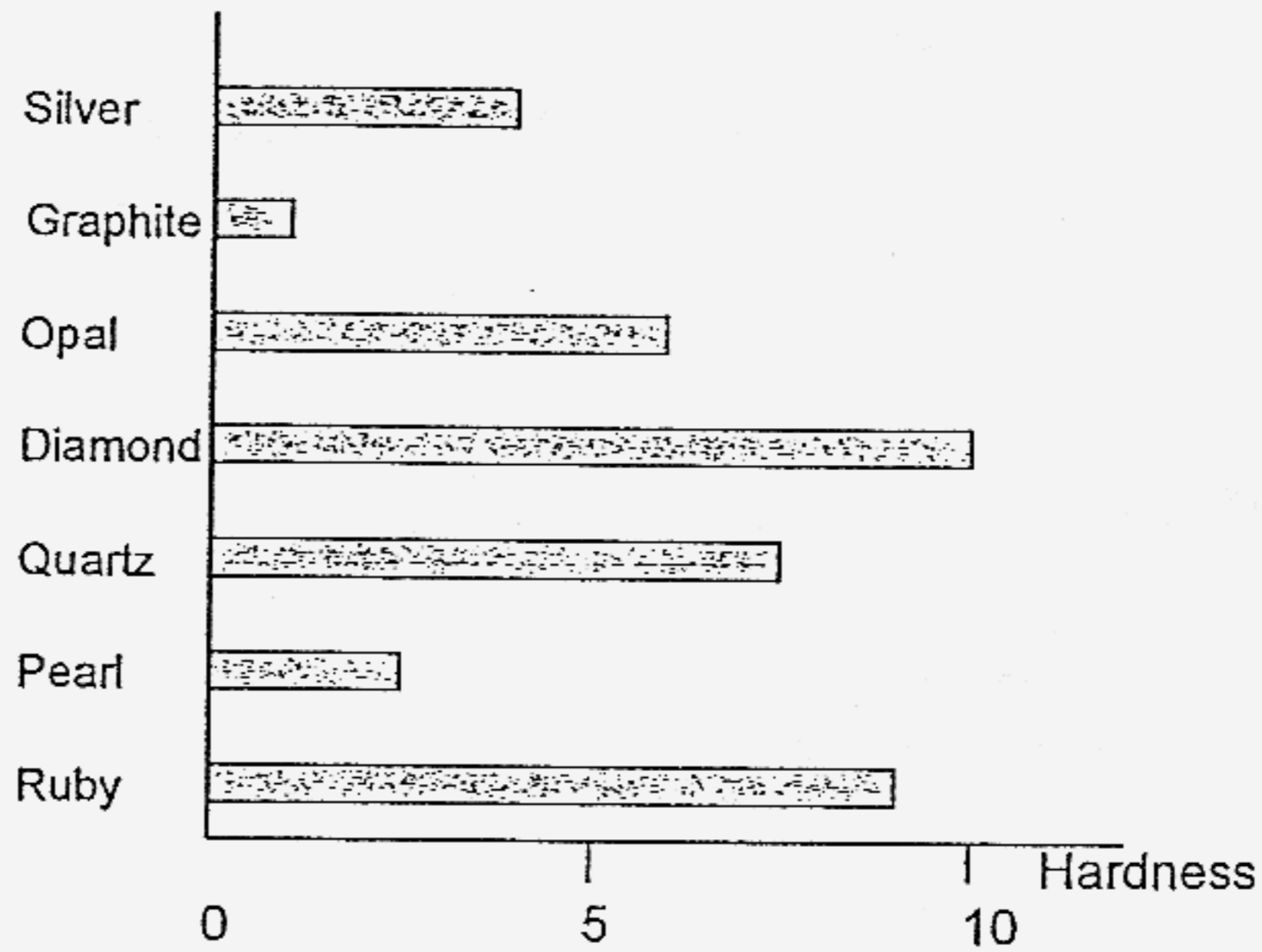

Which one of the arrangements shows three minerals in ascending order of hardness?

- (1) ruby, quartz, opal
 - (2) opal, quartz, ruby
 - (3) graphite, opal, silver
 - (4) diamond, ruby, quartz
22. Which one of the simple machines below uses the principle of the inclined plane as well as the principle of the wheel and axle?

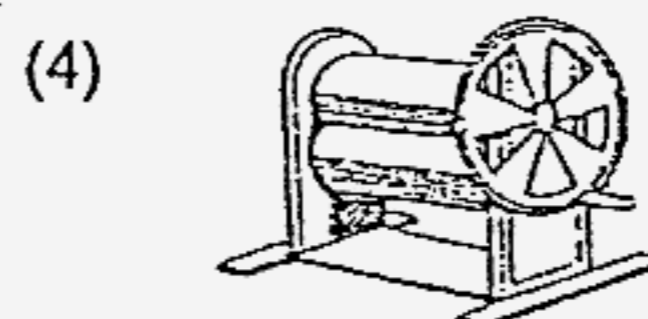
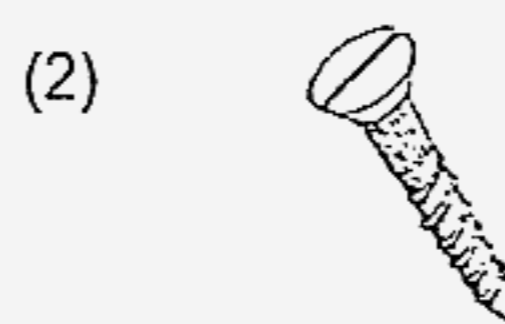
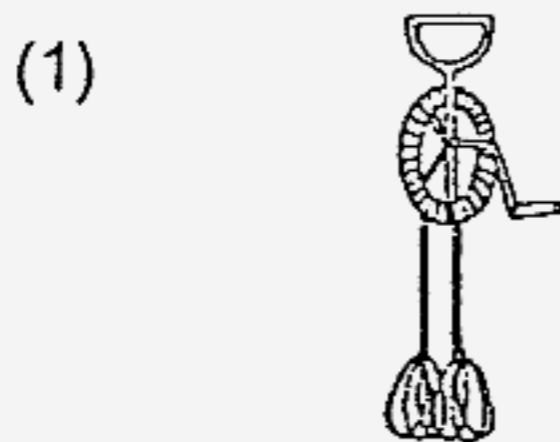

23. Study the experiment below.

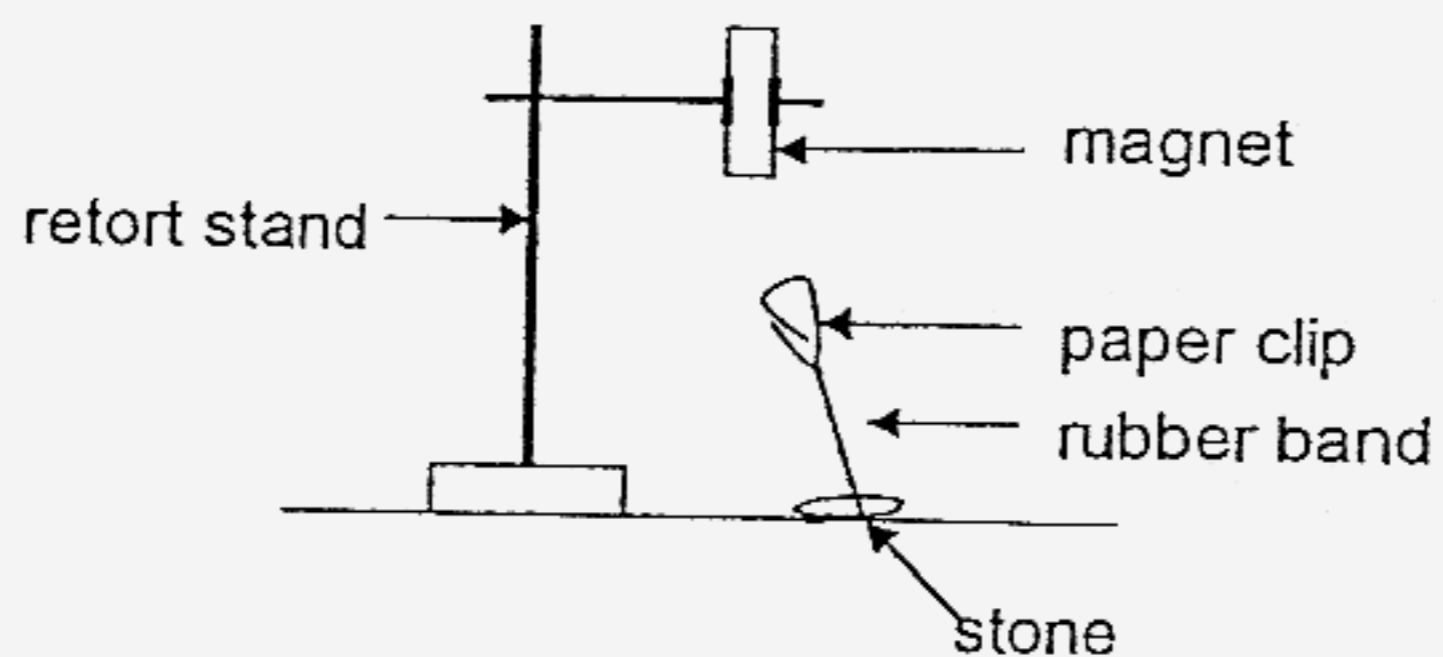

What are the forces acting on the paper clip?

- A Magnetic force
- B Frictional force
- C Gravitational force
- D Elastic spring force

- (1) A and C only
- (2) B and C only
- (3) B and D only
- (4) A, C and D only

24. Ting Ting carried out a test on four different types of tissue papers, W, X, Y and Z. The diagrams below show what she did.

Step 1: Cut tissue papers of the same size.

Step 2: Put them into 4 similar beakers with the same amount of water in each.

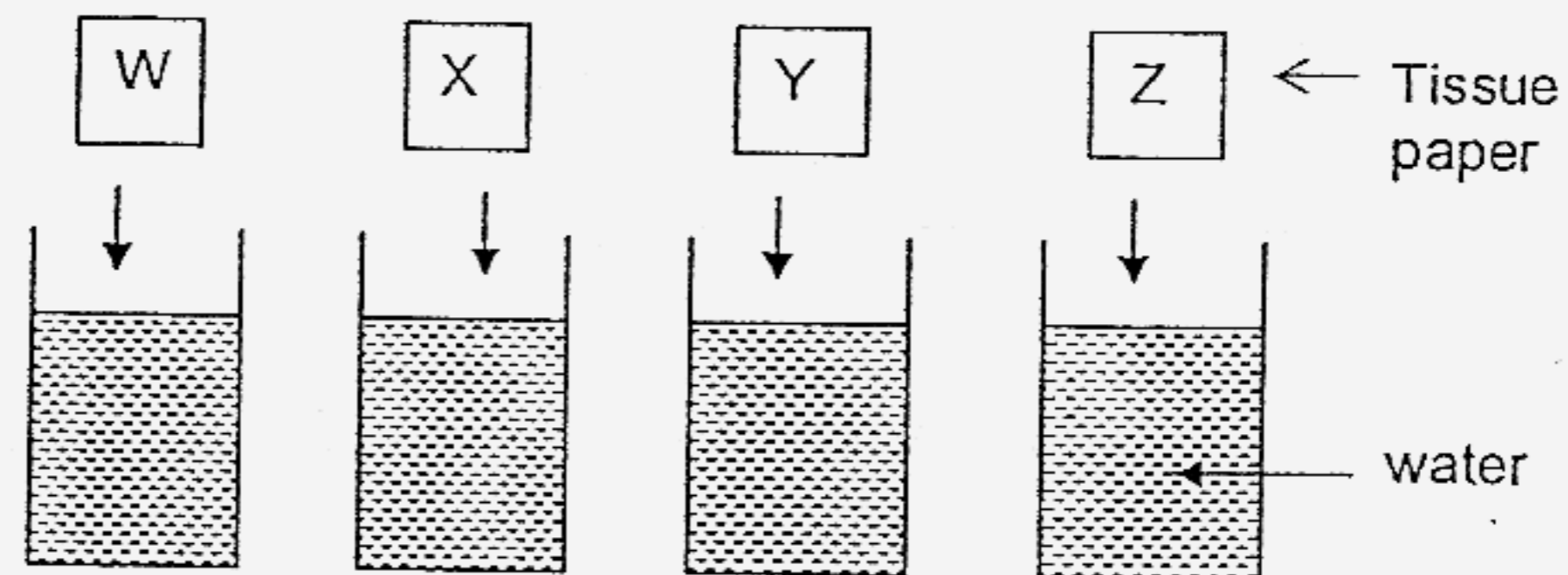

Step 3: Remove the tissue papers after 5 minutes.

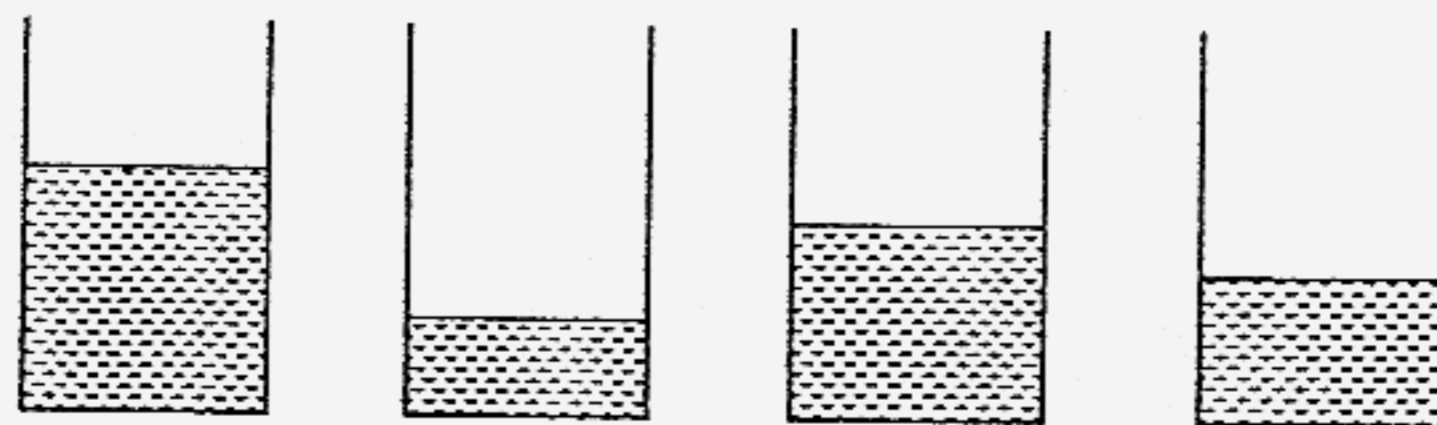

Step 4: Observe the water left in each beaker.

Based on the amount of water left in each beaker of Ting Ting's experiment, which type of tissue paper was the least absorbent?

- (1) Tissue Paper W
- (2) Tissue Paper X
- (3) Tissue Paper Y
- (4) Tissue Paper Z

25. A block of wood was pulled across 3 different surfaces, A, B and C. The force needed to pull the block on each surface was measured.

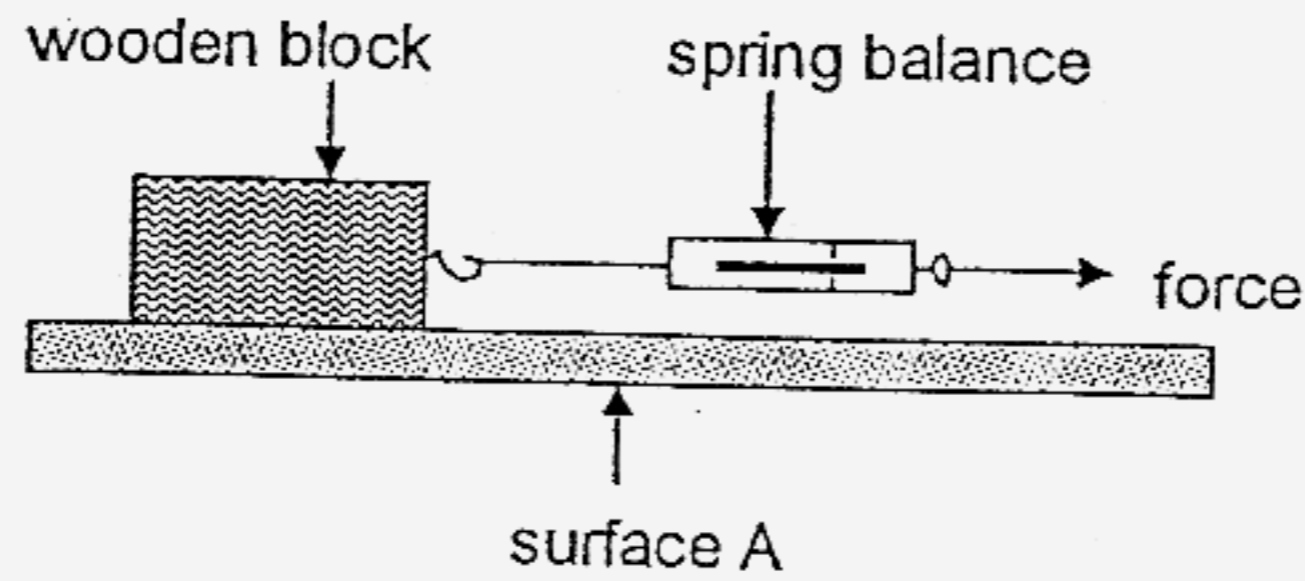

The results are shown in the table below.

Surface Tested	Force needed (Newtons)
A	21
B	16
C	18

Which one of the following surfaces best represent A, B and C respectively?

	Surface A	Surface B	Surface C
(1)	glass	concrete	sandpaper
(2)	sandpaper	concrete	glass
(3)	concrete	sandpaper	glass
(4)	sandpaper	glass	concrete

26. A big block of ice is left in a small room to melt. The table below shows the possible changes to the temperature of the ice, water and small room while the ice is melting. Which one of the following lists shows the correct changes?

	Temperature		
	Ice	Water	Room
(1)	No change	Increase	Decrease
(2)	No change	Increase	Increase
(3)	Increase	Decrease	Decrease
(4)	Increase	Increase	No change

27. The water in the four cylinders below has the same temperature.

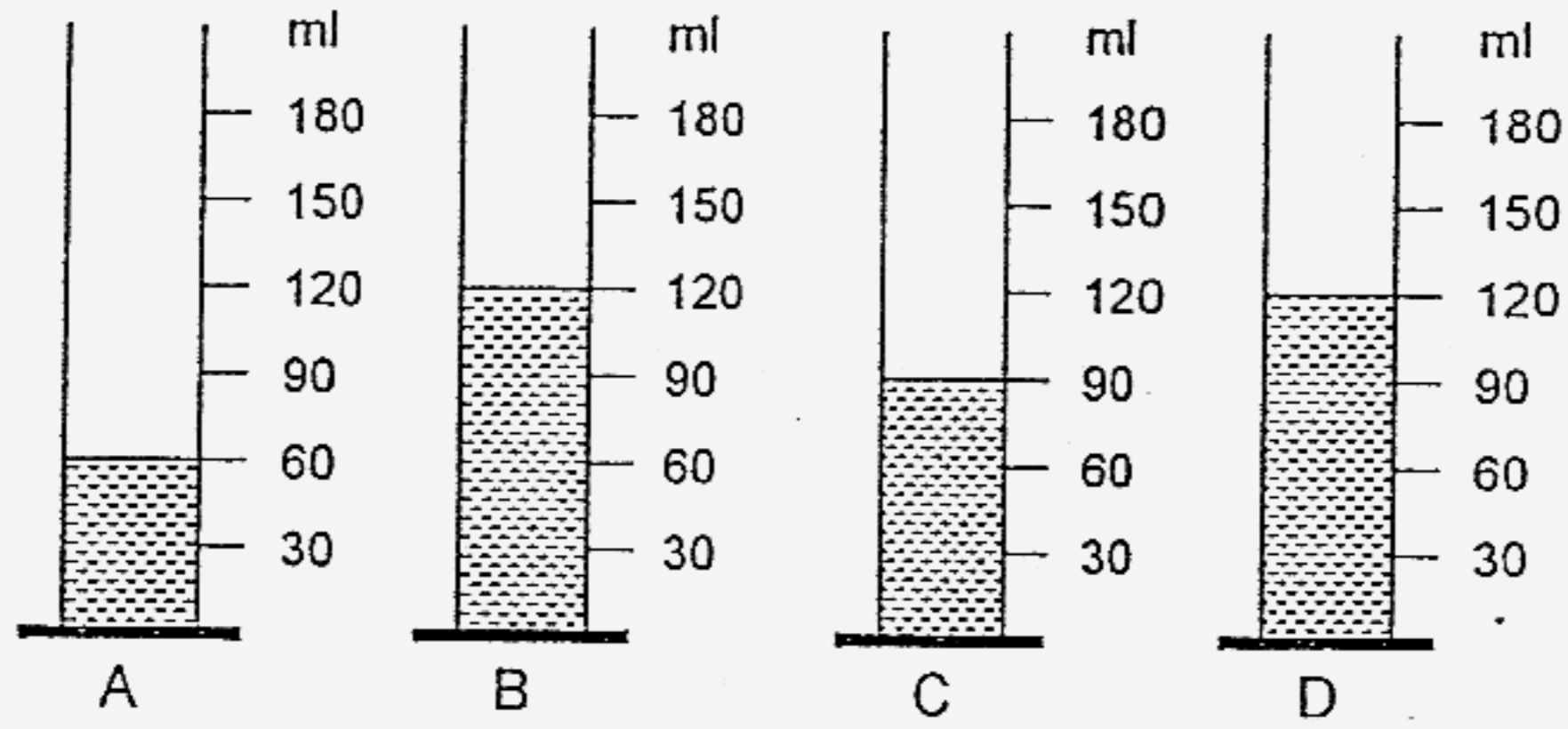

Lela added 50ml of boiling water to each cylinder. Which one of the following graphs shows the correct changes in the temperature of the water when the boiling water is added?

(1)

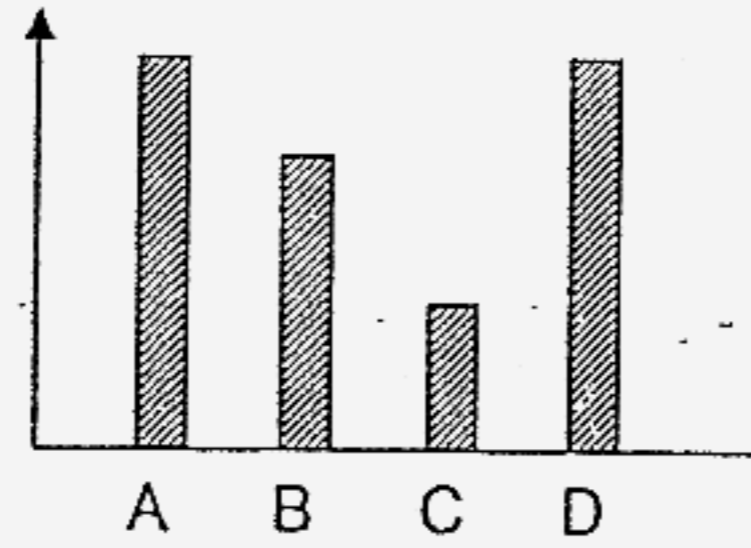

(2)

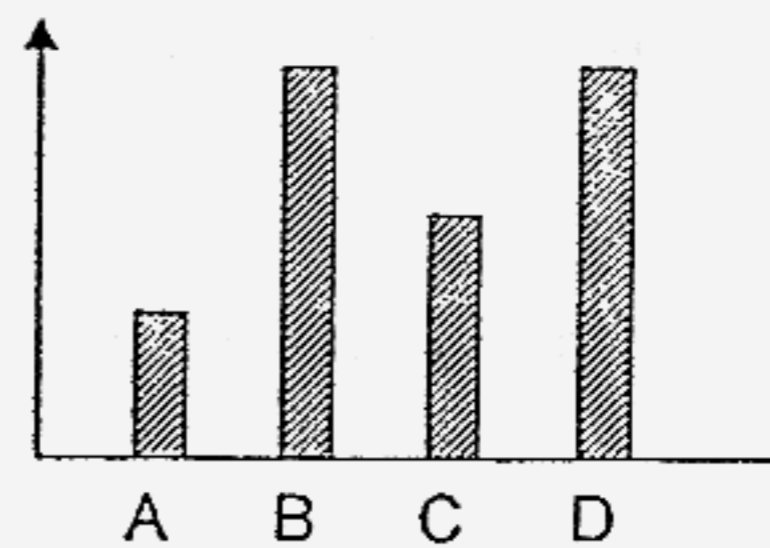

(3)

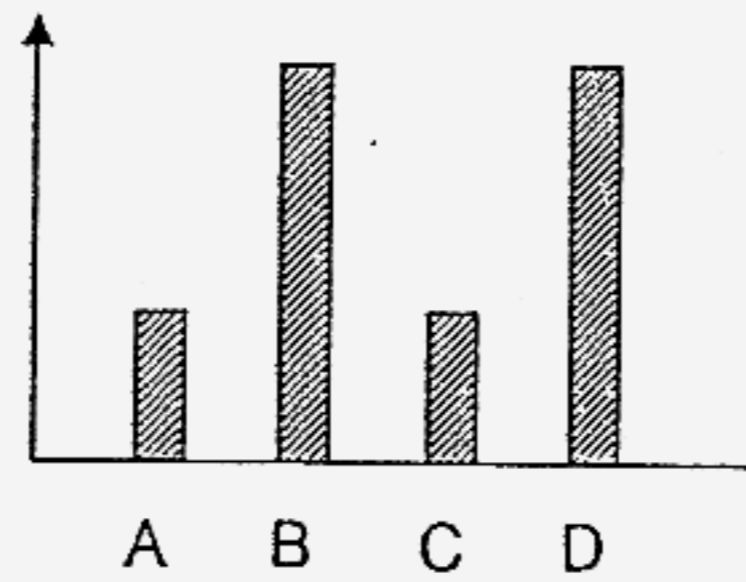

(4)

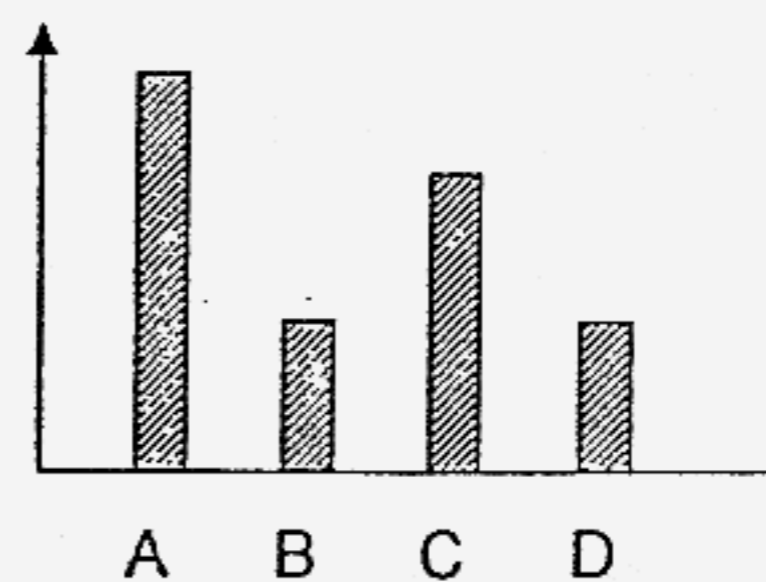

28. The diagram below shows a circuit with 3 bulbs.

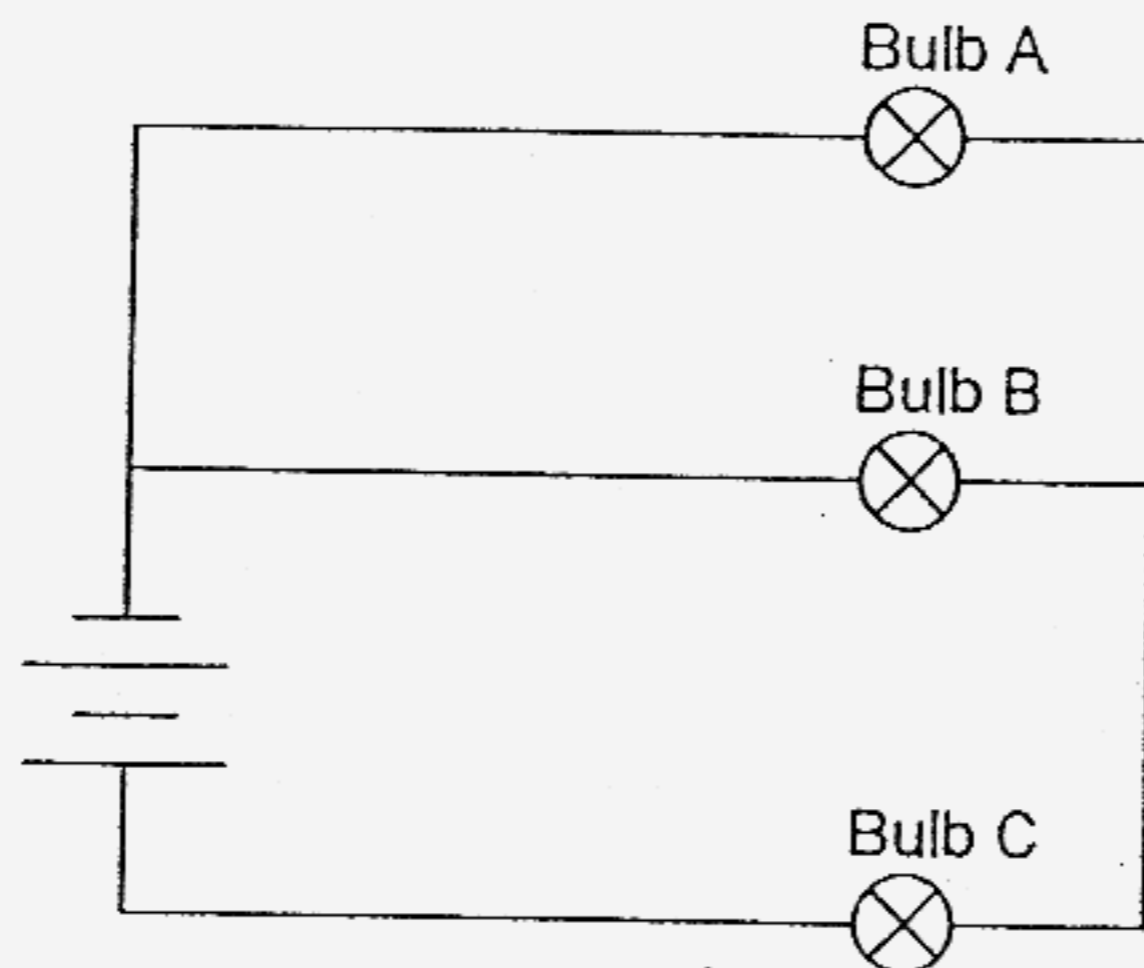

What would happen if bulb C fused?

- (1) Only bulb A will light up.
- (2) Bulbs A and B will light up.
- (3) Bulb A will light up more brightly.
- (4) None of the bulbs will light up.

29. Study the classification table below carefully.

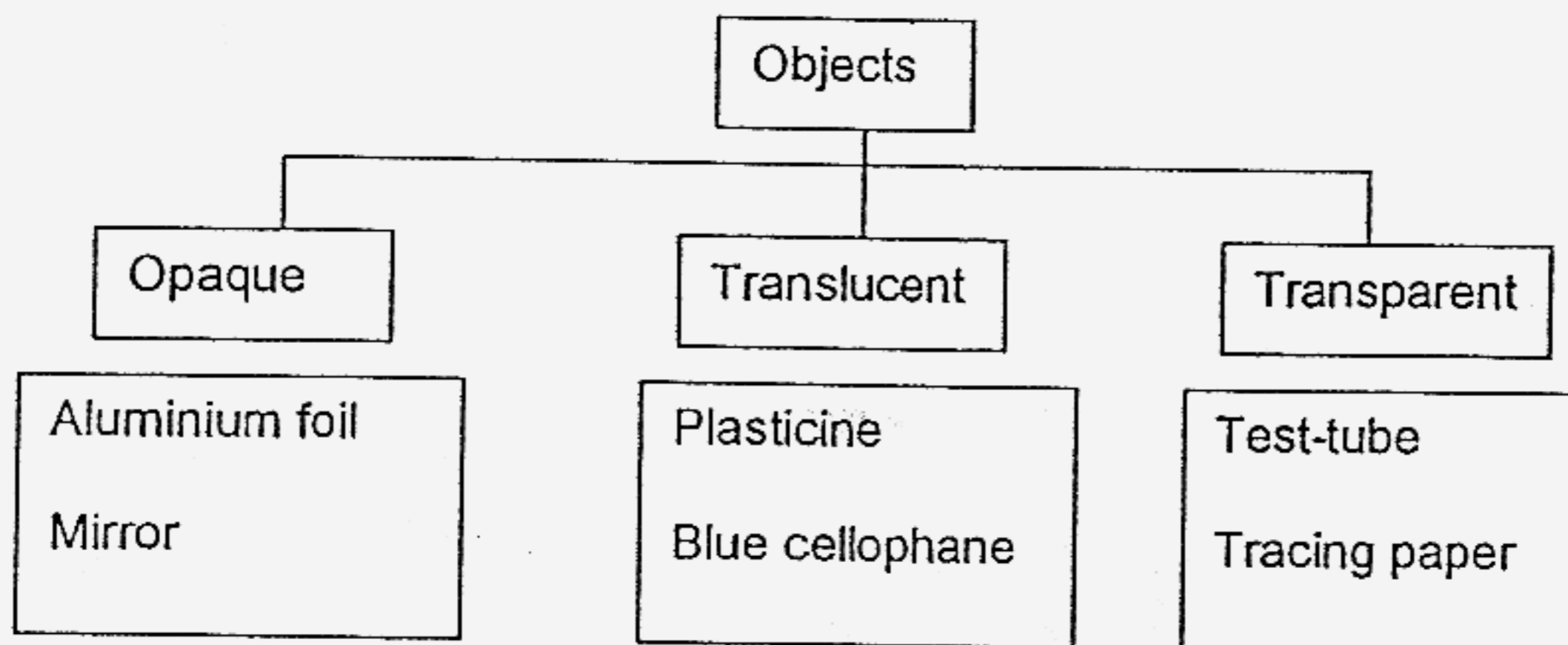

Which object(s) is/are placed in the wrong group?

- (1) Plasticine only
- (2) Mirror and tracing paper
- (3) Blue cellophane and mirror
- (4) Plasticine and tracing paper

30. A beaker is placed on a table as shown below. It contains two substances X and Y at room temperature as shown in figure 1.

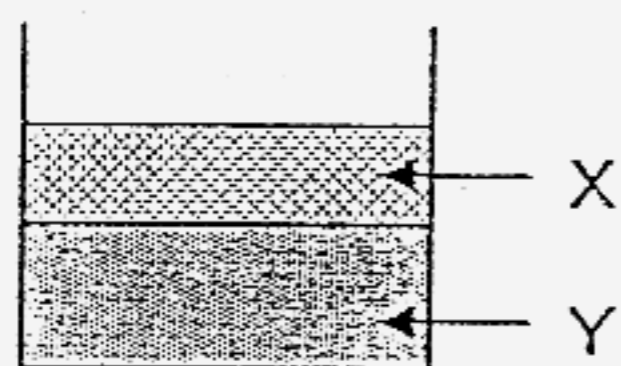

Figure 1

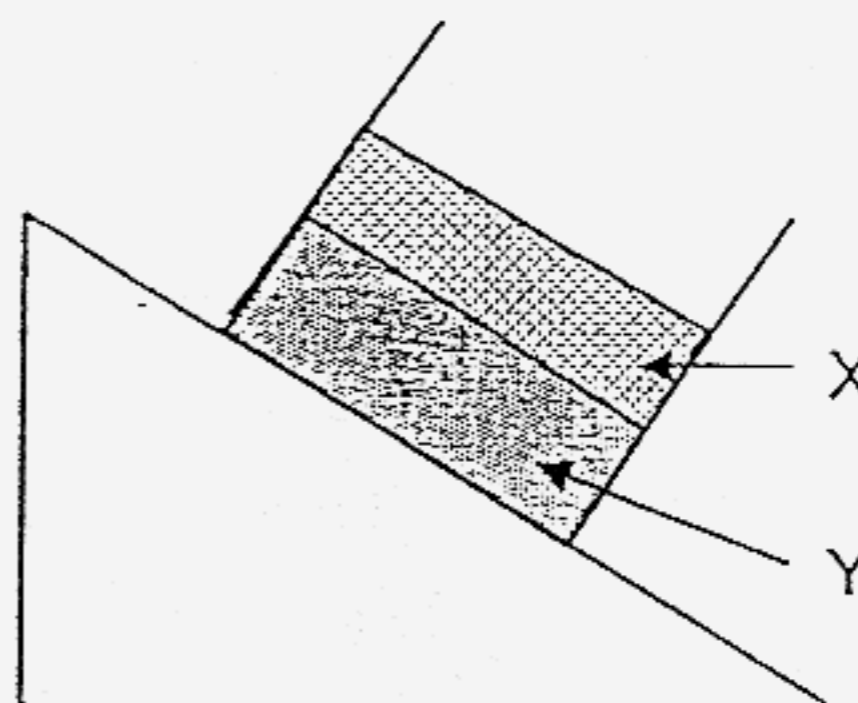

Figure 2

The same beaker with its contents are placed on a ramp as shown in figure 2.

Which one of the substances could X and Y be?

	Substance X	Substance Y
(1)	wax	water
(2)	oil	water
(3)	jelly	wax
(4)	butter	honey

~~~ END OF SECTION A ~~~

**Section B** (40 marks)

For questions 31 - 46, write your answers in this booklet.

31. The diagram below shows the life cycle of a housefly and a frog.

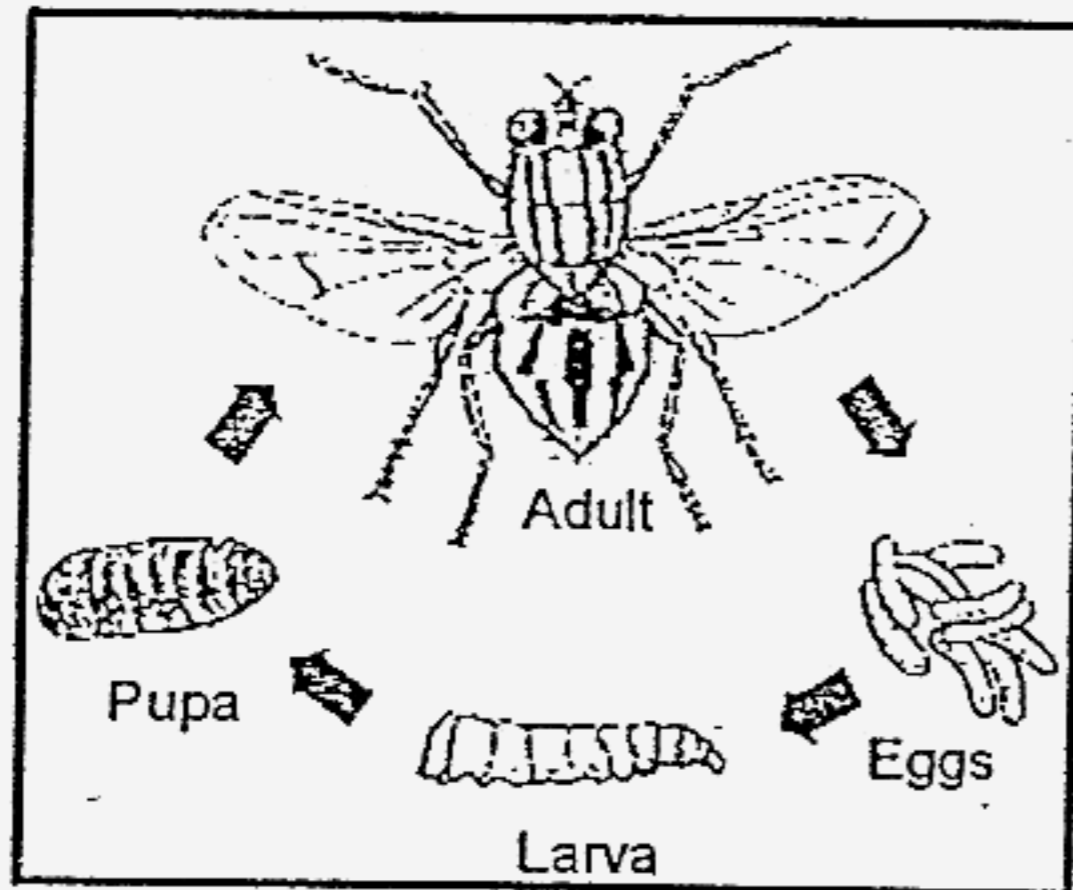

**Life cycle of a housefly**

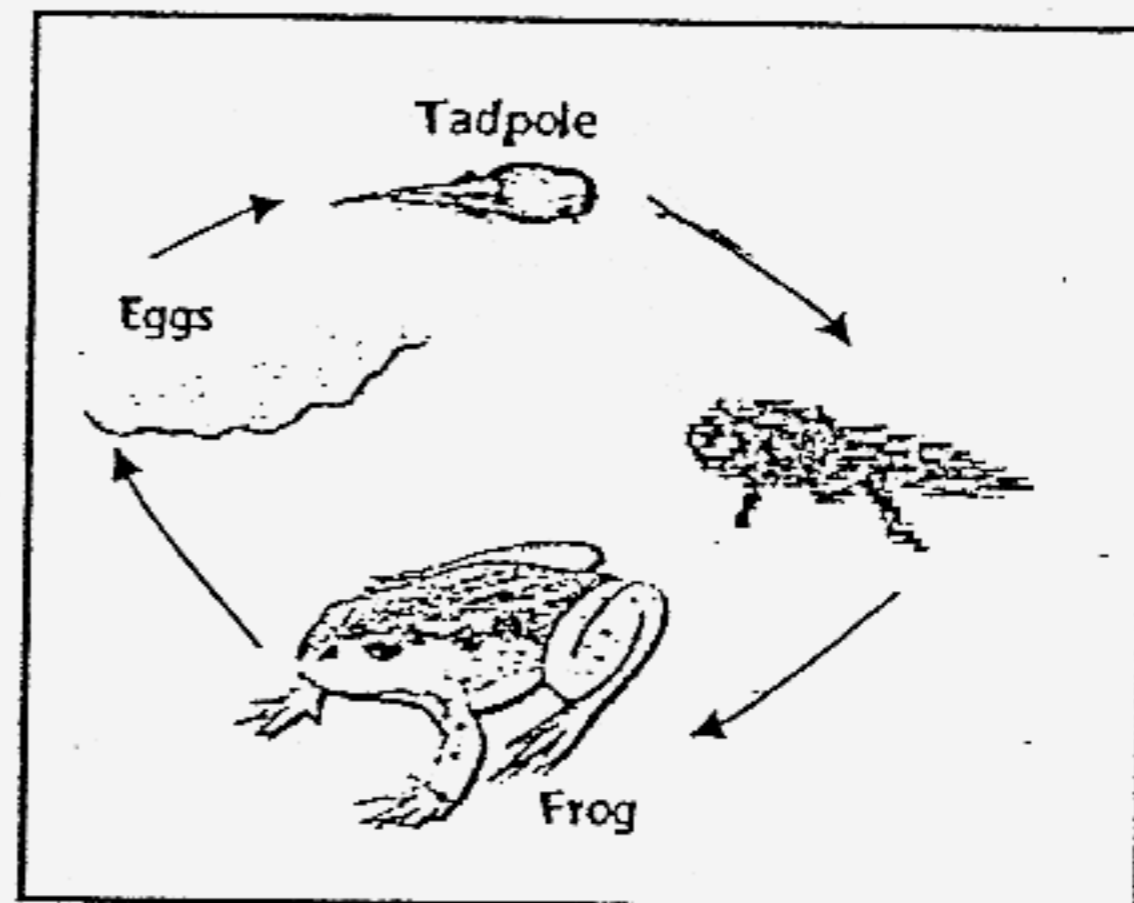

**Life cycle of a frog**

After studying the 2 life cycles, Nick came to the conclusion that a housefly and a frog undergo the same number of stages in their life cycles.

*frog*

(a) Has Nick made the right conclusion? Explain your answer. [1m]

---

(b) State a difference between the life cycle of a housefly and the life cycle of the frog. [1m]

---



32. Study the food web given below.

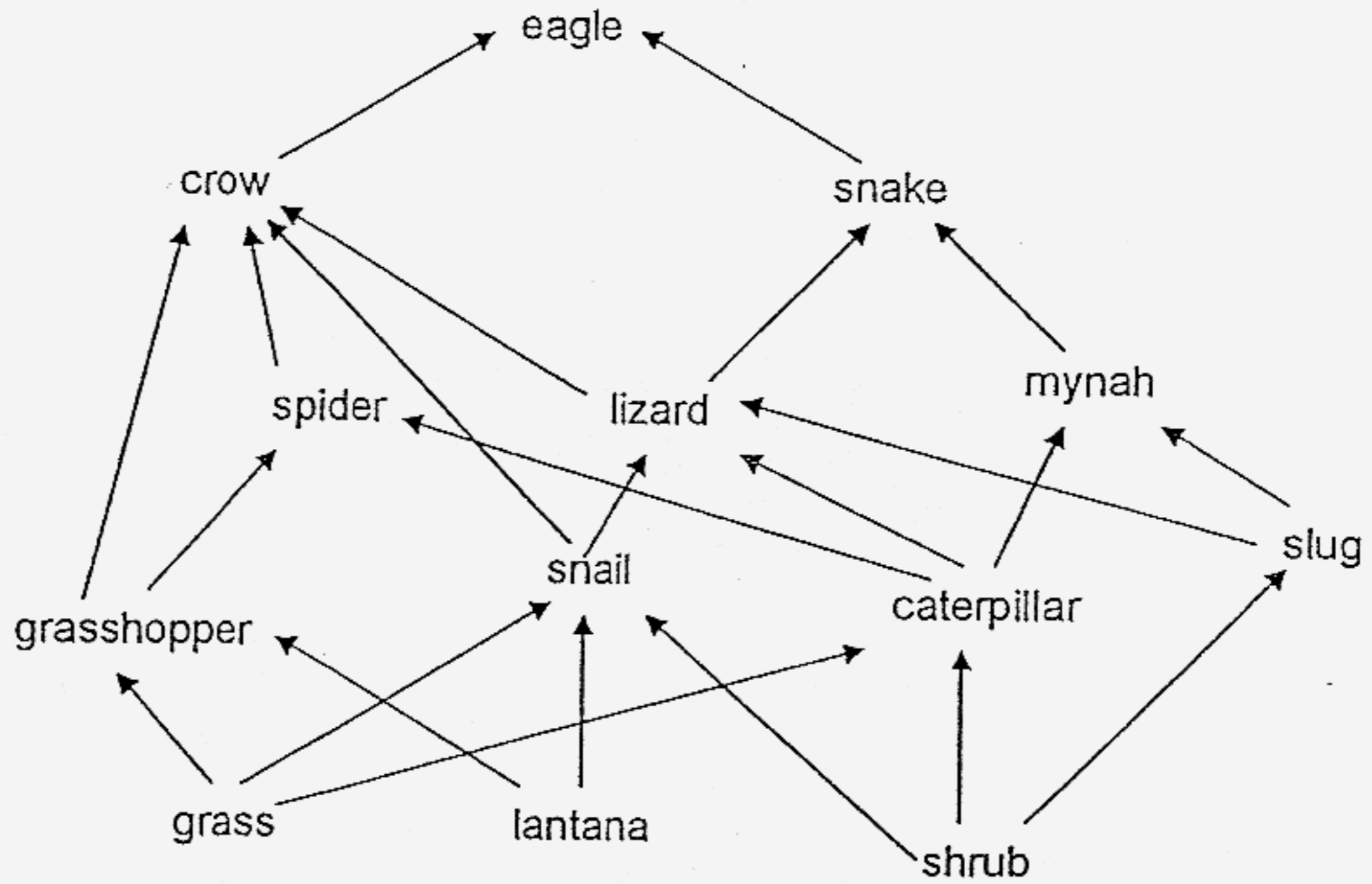

(a) Write down 2 food chains that involves at least 5 organisms? [1m]

(i) \_\_\_\_\_

(ii) \_\_\_\_\_

(b) In this community, are there likely to be more spiders or more caterpillars? Explain your answer. [1m]

\_\_\_\_\_

(c) After looking at the food web, Mary remarked, "The snail is both a predator and a prey." Do you agree? Explain your answer. [1m]

\_\_\_\_\_



33. Jason bought a do-it-yourself mushroom growing kit from the Primary Production Department. He was hoping to harvest his own crop of White Oyster Mushrooms. As he conducted his experiment of growing mushrooms, he recorded down his observations.

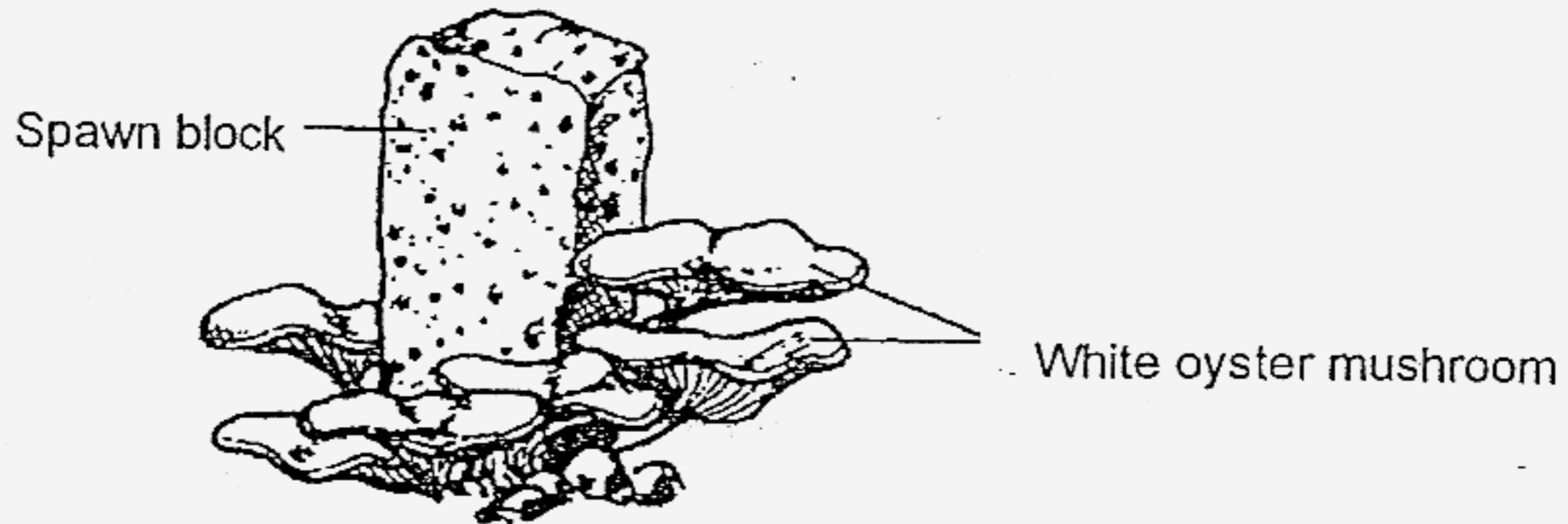

- A Little "knobs" appeared on the surface of the block in a few days.
- B After 1 week, I harvested my first crop of mushrooms.
- C The spores from which the mushrooms grew and the nutrients they required for growth came from the spawn block.
- D I sprayed the block with water two to three times a day and covered the block with a bag which has holes after each spraying.
- E On the 16<sup>th</sup> and 25<sup>th</sup> day, I harvested my second and third crop.

- (a) What would Jason observe if he were to conduct his experiment in bright sunlight? Why?

---

- (b) Which one of the observations A, B, C, D or E, recorded by Jason has been inferred by him to arrive at his conclusion in (a)? [1m]

---



34. Seeing fallen leaves on her vegetable plot, Susan decided to conduct an experiment with them. She smeared different surfaces of two identical leaves with oil and hung them in a windy place as shown below. She then weighed the leaves every day for 3 days.

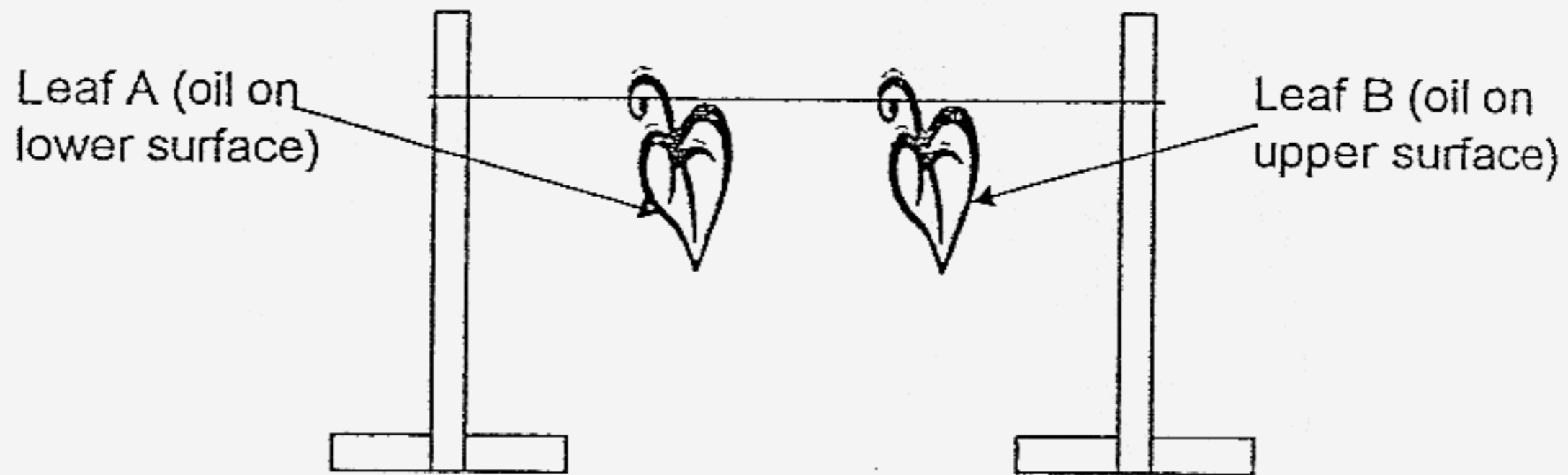

- (a) The change in weight of leaf A is shown in the graph below. Draw another graph to indicate the change in weight of leaf B. [1m]

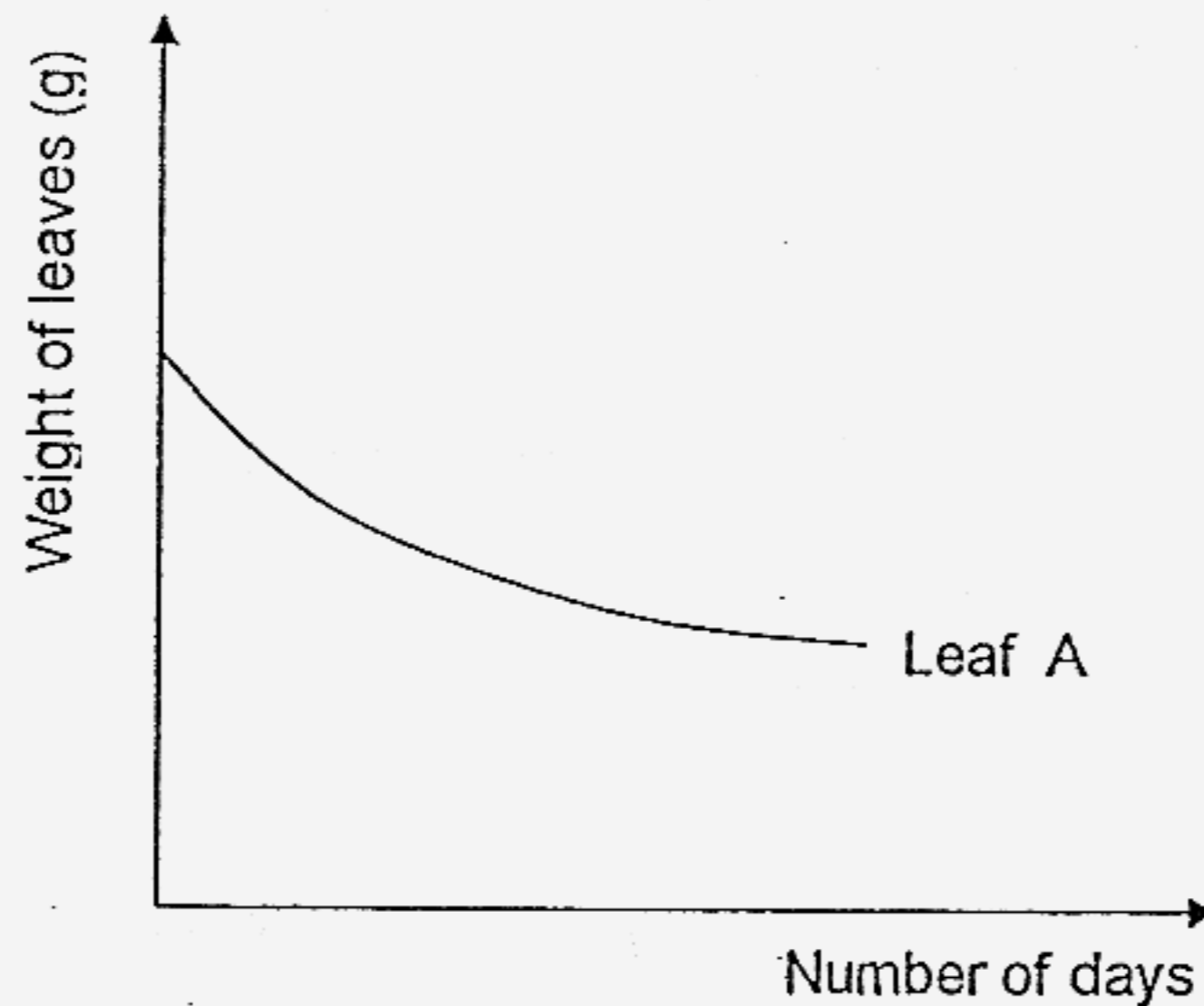

- (b) Susan went on to smear all the leaves of a plant with oil and she noticed that the plant wilted after 2 days. Suggest 2 reasons why this happened. [2m]

(i) \_\_\_\_\_

(ii) \_\_\_\_\_



35. Study the diagrams of 2 skeletons shown below.



Skeleton Q

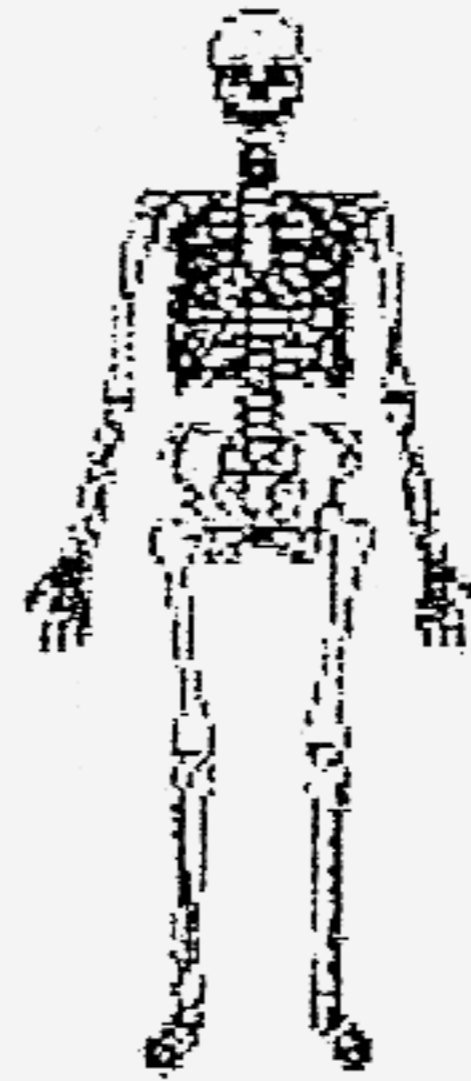

Human Skeleton

- (a) State one difference between skeleton Q and a human skeleton. (Do not compare posture) [1m]

---

- (b) How does this adaptation help animal Q to survive in the rainforest? [1m]

---

- (c) Name an animal which has the same skeletal structure as Q. [1m]

---

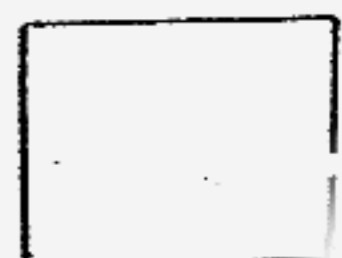



36. Study the flowchart below carefully.

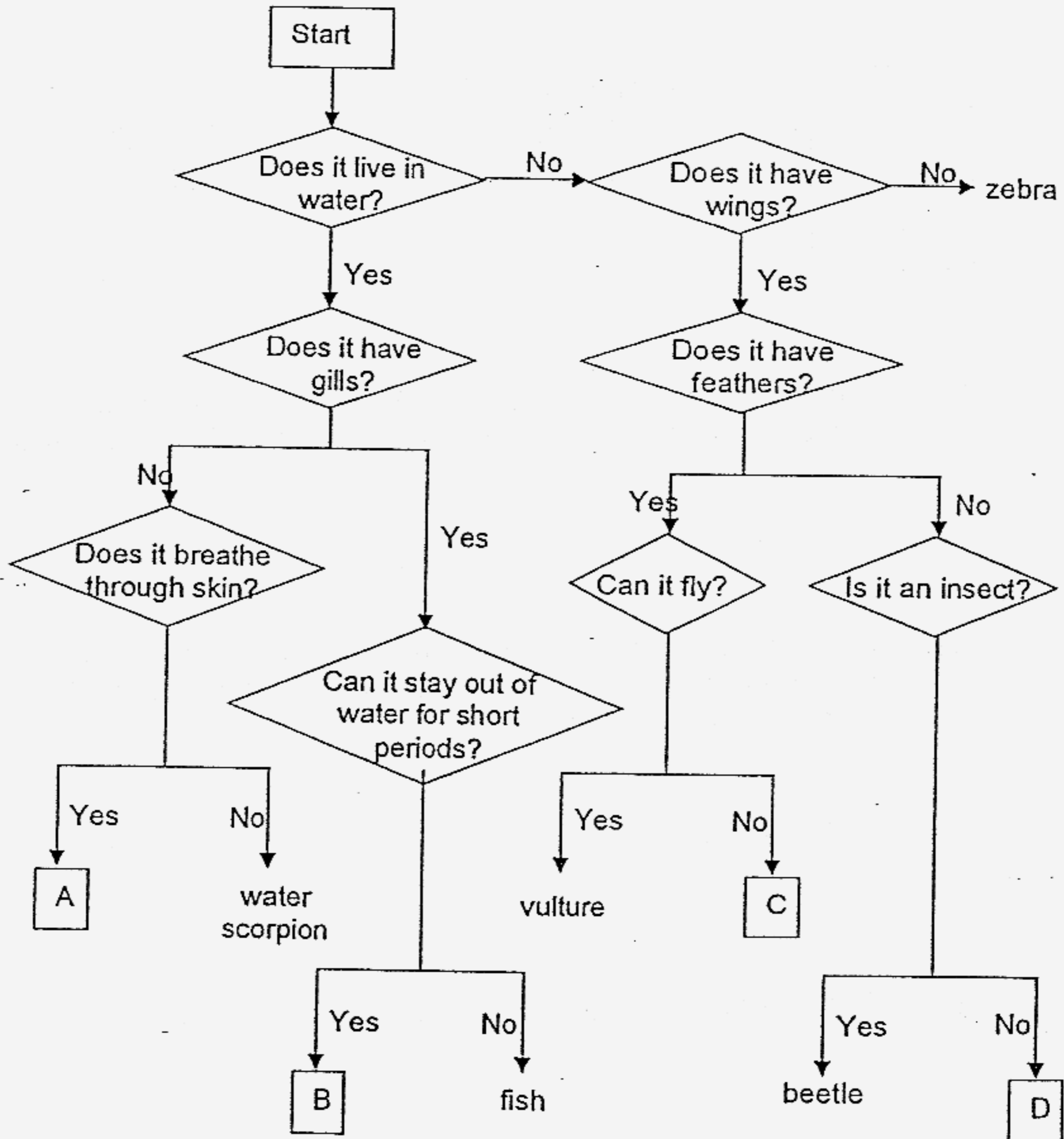

Identify the animals represented by the following letters of the alphabet:

[2m]

- (a) A: \_\_\_\_\_
- (b) B: \_\_\_\_\_
- (c) C: \_\_\_\_\_
- (d) D: \_\_\_\_\_

61

37. Rubbish in a town was collected and disposed of by incineration burning, burying or dumping. Study the table carefully.

| Year | Rubbish collected (tonnes) | Rubbish disposed (tonnes) |
|------|----------------------------|---------------------------|
| 2004 | 4800                       | 3500                      |
| 2006 | 5400                       | 3000                      |

- (a) More rubbish was collected in 2006 yet less of it was disposed of. Suggest a possible reason for the reduced rubbish disposed in that year. [1m]

\_\_\_\_\_

- (b) Rubbish can be disposed of by incineration burning. What is the advantage and disadvantage of using this method of rubbish disposal compared to burying? [1m]

(i) Advantage: \_\_\_\_\_  
\_\_\_\_\_

(ii) Disadvantage: \_\_\_\_\_  
\_\_\_\_\_

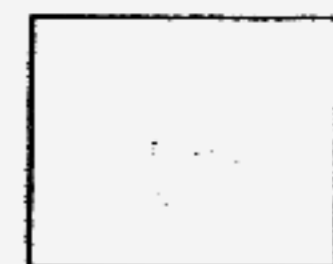

38. Amy conducted an experiment by filling 2 containers, R and S, with equal amounts of Liquid X. She placed some fallen flowers in a bag with many tiny holes and hung it in Container S. One week later, Liquid X in Container R remained clear but Liquid X in Container S had turned cloudy.

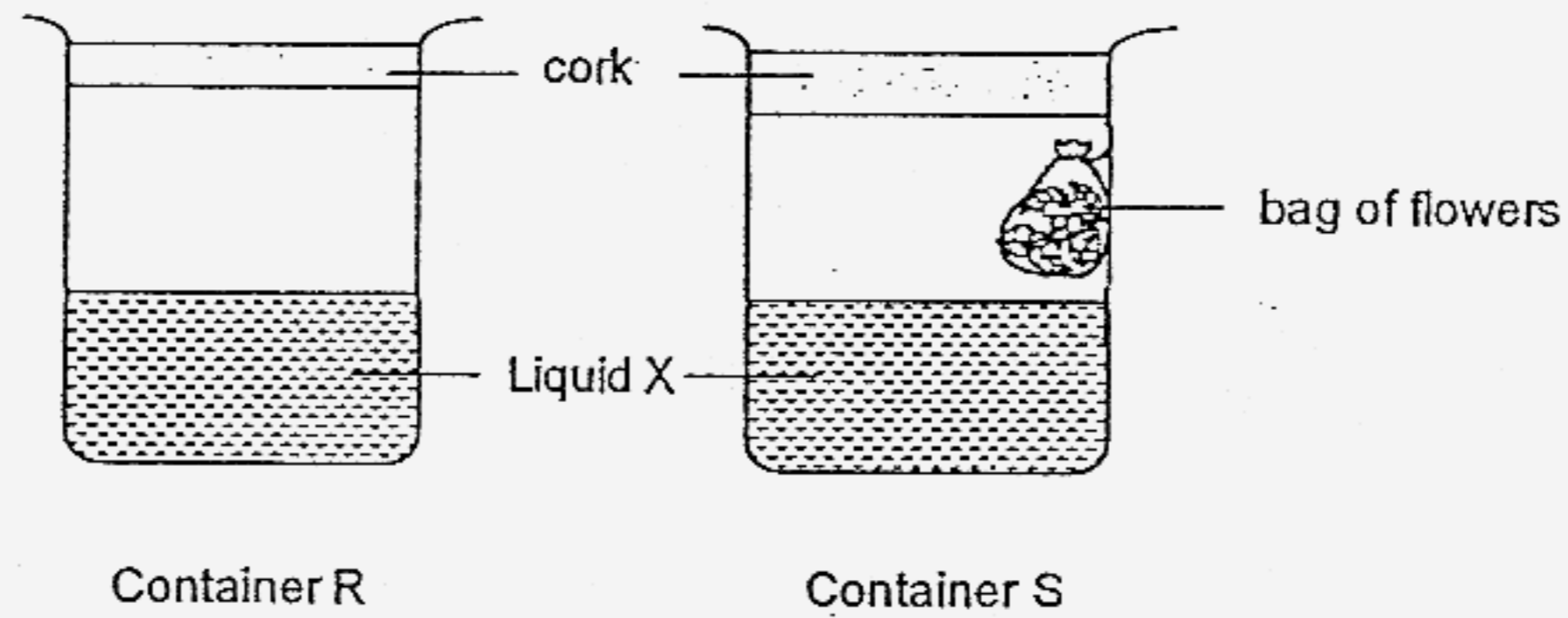

- (a) Name Liquid X. [1m]
- 
- (b) What process had taken place to cause Liquid X to turn cloudy? [1m]
- 
- (c) Why did Amy use a bag with many holes to hold the flowers? [1m]
- 

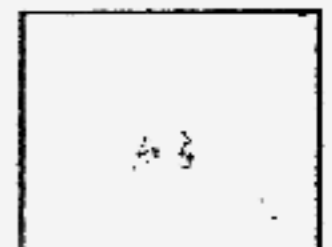

39. The diagram below shows a hydro-electric power station.

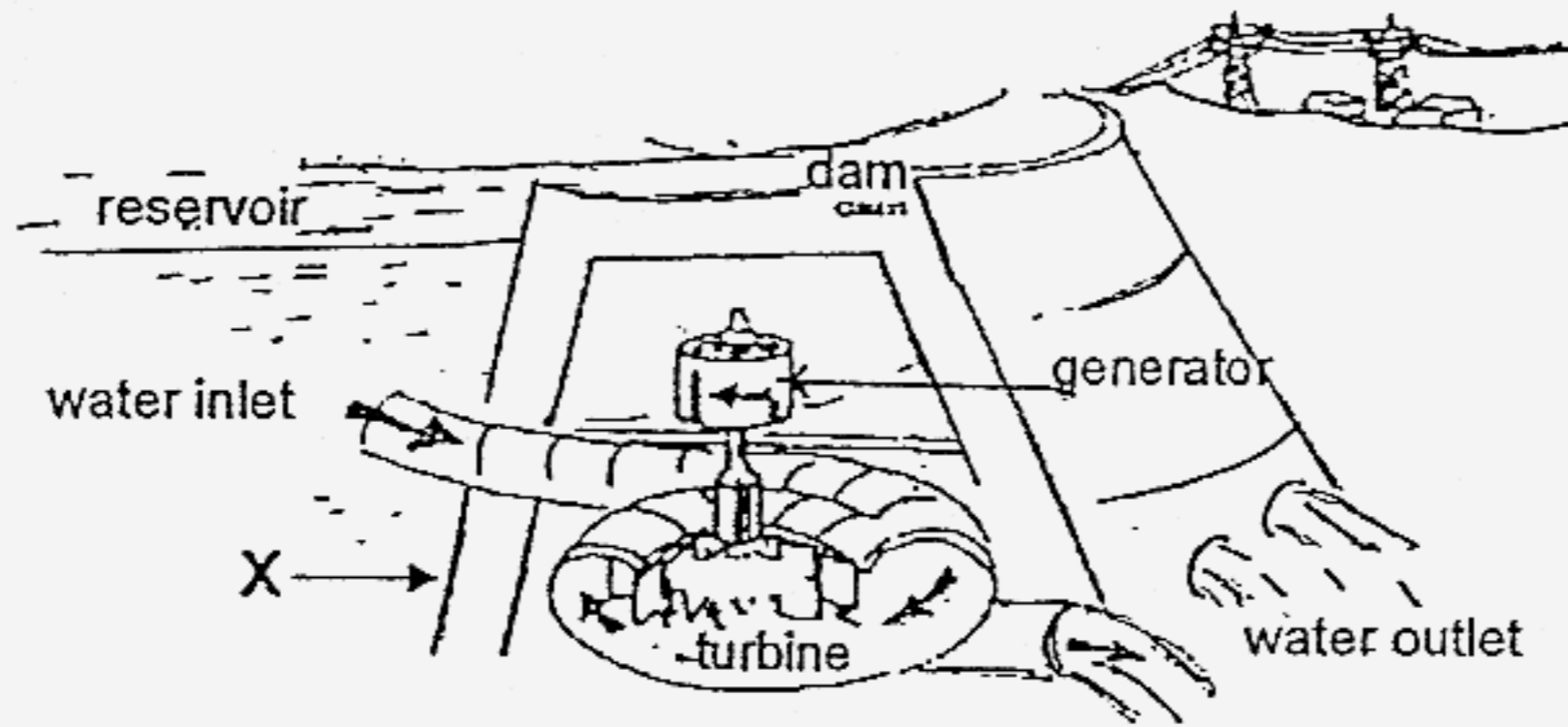

(a) Fill in the boxes with the correct type of energy at the following parts of the station. [2m]

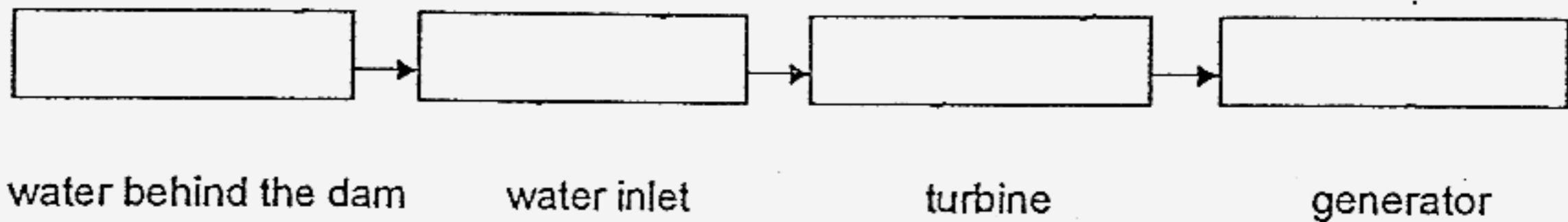

(b) How would it affect the generator if the water inlet is lowered to the part mark X? [1m]

40. Listed below are two processes.

Process A: Freezing of water  
Process B: Melting of wax

(a) What change of state has taken place in process B. [1m]

\_\_\_\_\_

(b) Other than a change of state, state another similarity between the two processes. [1m]

\_\_\_\_\_

(c) Energy X plays an important role in both processes. What is energy X? [1m]

\_\_\_\_\_



41. Steve tested 4 pieces of materials, A, B, C and D, in a cardboard holder as shown in the diagrams below.

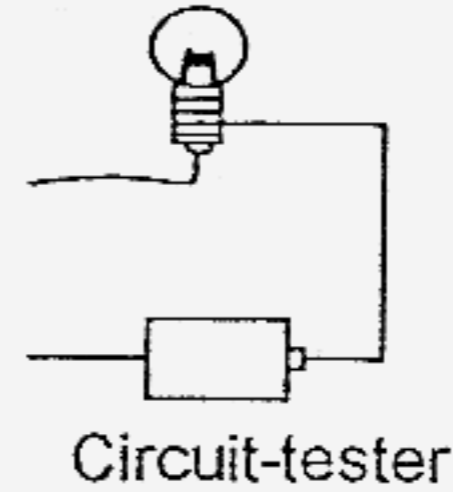
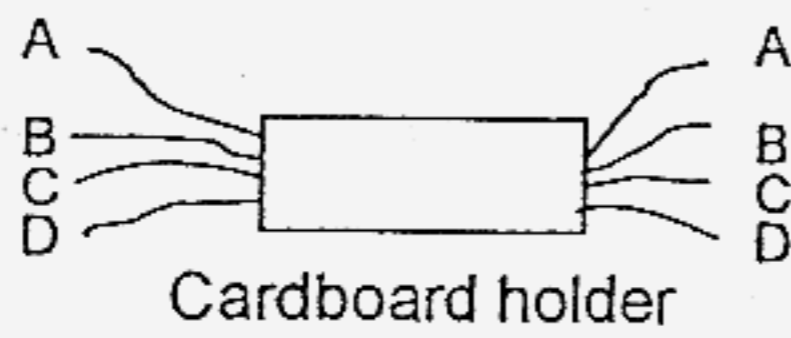

He connected the ends of two materials together and joined the corresponding ends to the circuit-tester. The diagrams below show the results he obtained.

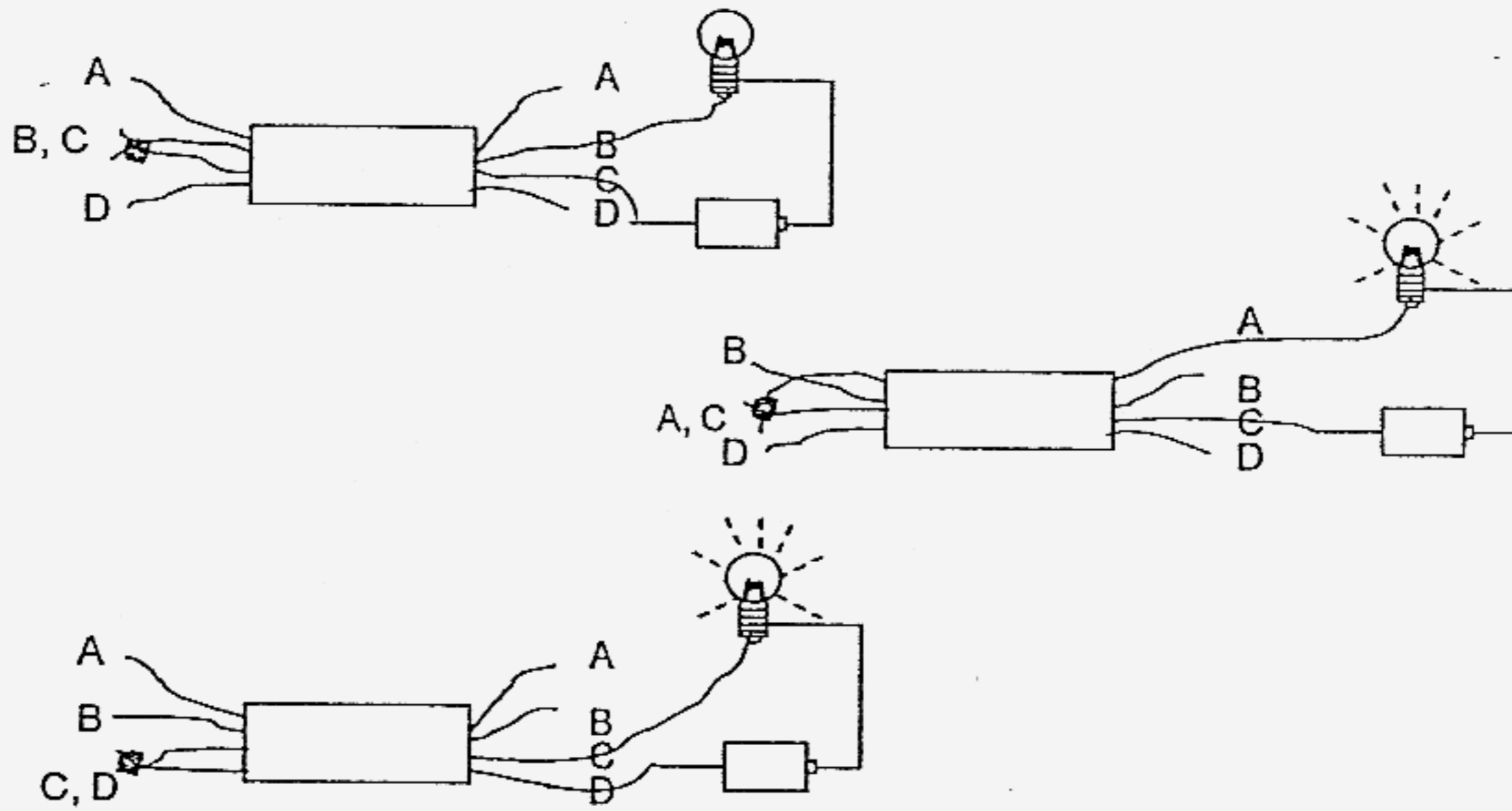

- (a) What will you observe when materials B and D are connected to the circuit-tester? [1 m]

---

- (b) From the results of Steve's test, what conclusion can you draw on material B? [1 m]

---



42. (a) Complete the statement below by filling in each blank with a suitable word. [1m]

The moon makes one \_\_\_\_\_ round the Earth in about 28 days and the changes in the shape of the moon are called \_\_\_\_\_ of the moon.

- (b) The diagram below shows the positions of the Moon at different times of the month.

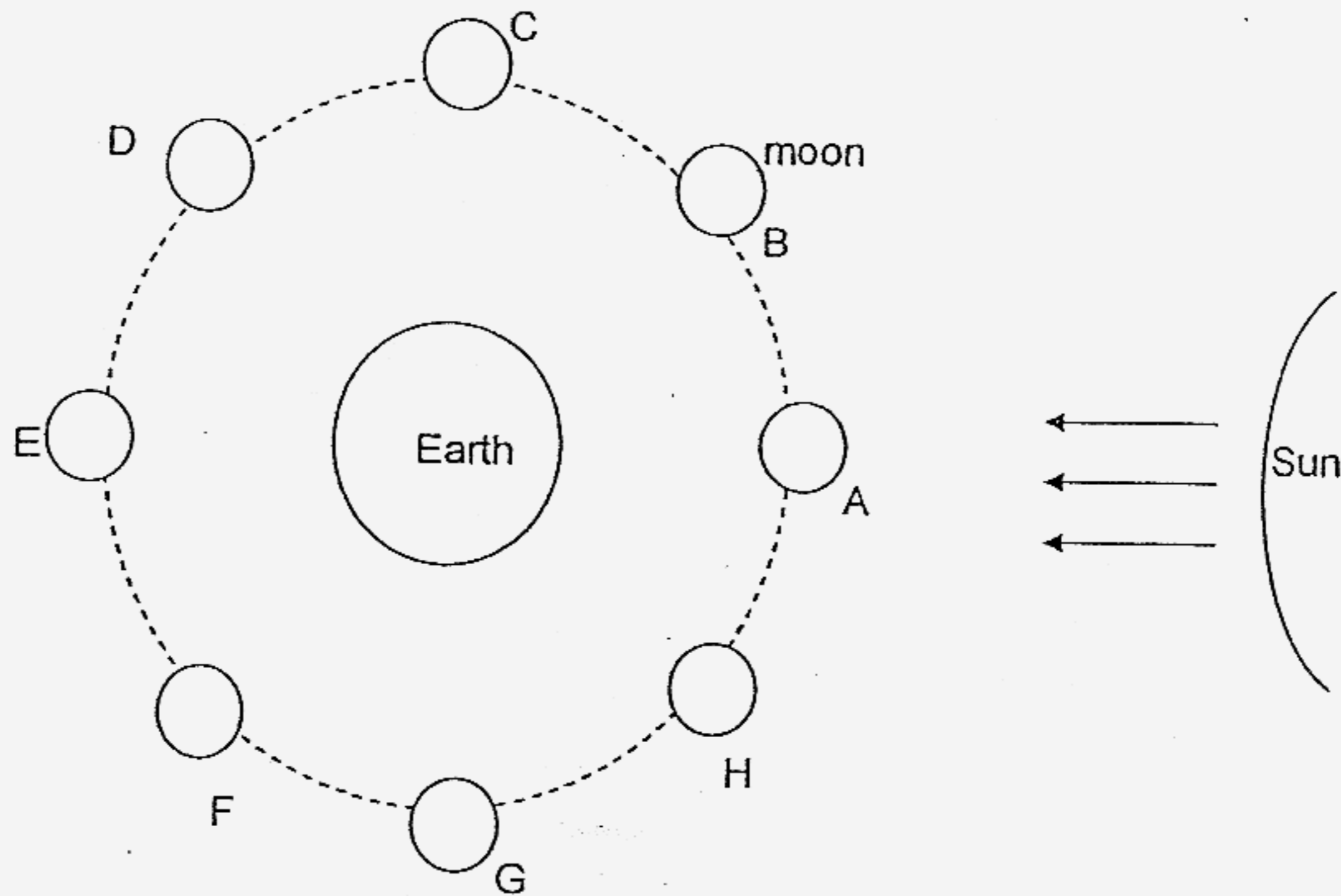

At which position(s) will the gibbous moon be observed? [1m]

---





43. A group of students carried out an experiment with 4 copper sheets as shown in the diagram below to investigate the factors that affect the heat absorption rate of materials.

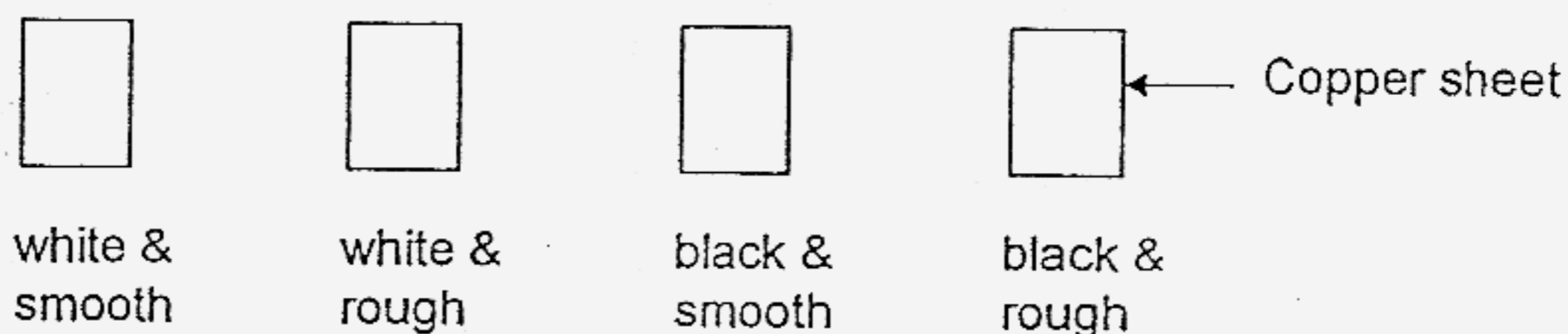

They put the 4 copper sheets in a sunny place for 10 minutes before measuring their temperature. They recorded the results in the table below.

| Copper sheet   | Temperature (° C) |
|----------------|-------------------|
| White & smooth | 58                |
| White & rough  | 62                |
| Black & smooth | 64                |
| Black & rough  | 70                |

- (a) Based on the results of their experiment, which factor, colour or texture, affects the rate of heat absorption more? [1m]

- (b) Explain your answer in (a). [1m]

- (c) ~~The~~ They repeated the experiment by putting the 4 copper sheets together as shown in the diagram.

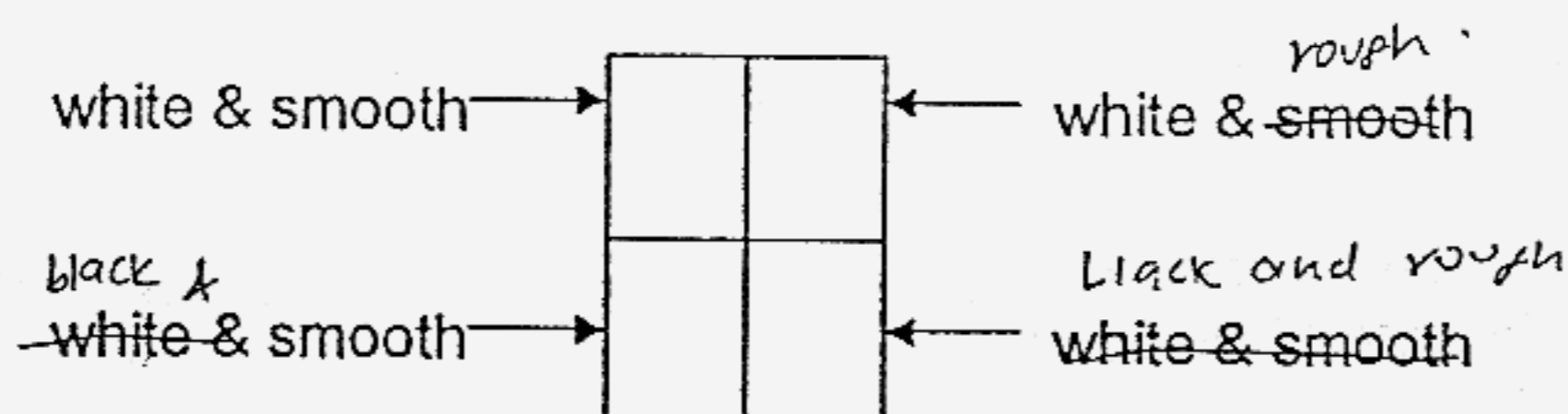

The results obtained were not the same as the first experiment. Suggest a reason for this. [1m]

44. The diagram below shows a glass container. It has a rubber stopper with a glass tube and a filter funnel.

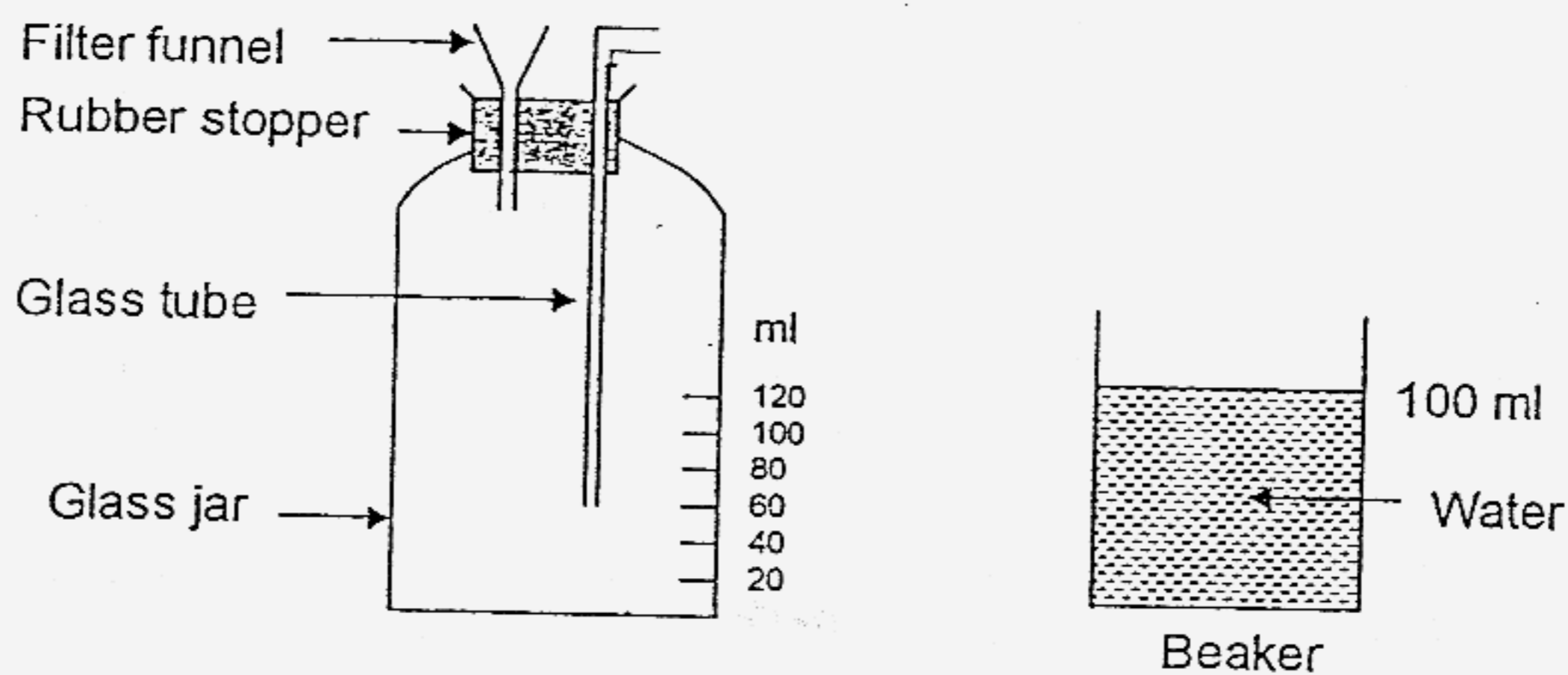

John found that he could not pour all the water in the beaker into the glass jar through the funnel with a narrow tube.

- (a) About how much water in the beaker could be poured into the glass jar?  
[1m]

- (b) Explain your answer in (a) above. (1m)

45. Study the information in the table below carefully.

| Set-up | Volume of water | Exposed surface area | Temperature | Wind speed |
|--------|-----------------|----------------------|-------------|------------|
| A      | 200 ml          | 100 cm <sup>2</sup>  | 35° C       | X km/h     |
| B      | 200ml           | 100 cm <sup>2</sup>  | 25° C       | Y km/h     |
| C      | 250ml           | 200 cm <sup>2</sup>  | 35° C       | X km/h     |
| D      | 250ml           | 200 cm <sup>2</sup>  | 25° C       | X km/h     |

- (a) Which two set-ups, A, B, C and D can be used to conduct a fair test on the rate of evaporation?  
[1m]

- (b) From your choice in (a) above, what can we find out about the rate of evaporation?  
[1m]

46. Three data-loggers were used to measure the amount of light at three different places in the school from 11am to 4pm. The results are shown in the graphs below.

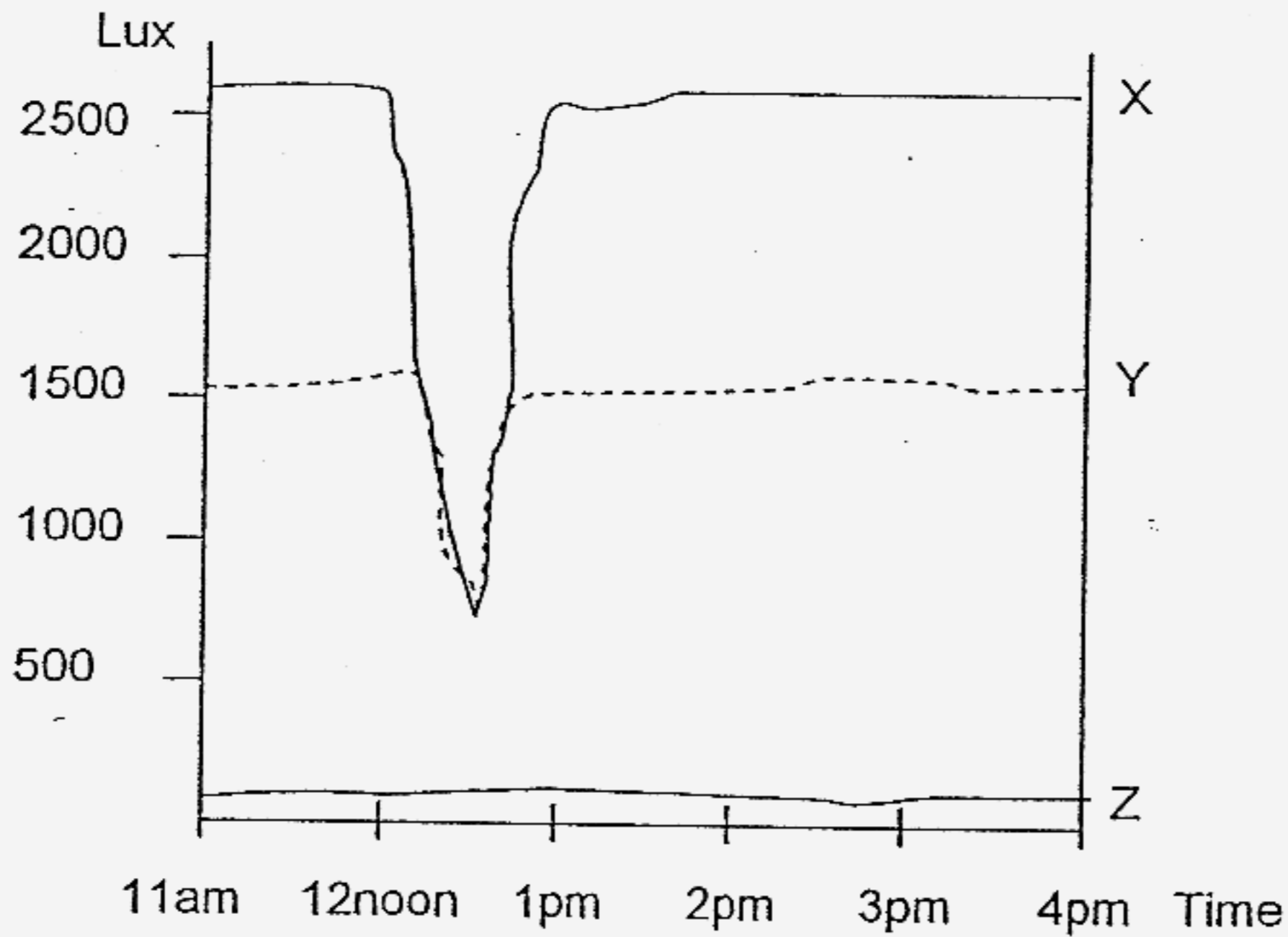

- (a) Based on the results shown, match the graphs X, Y or Z to the correct places listed below. [1m]

| Place | On the branch of a guava tree | In the tennis court |
|-------|-------------------------------|---------------------|
| Graph |                               |                     |

- (b) What could have caused the change in graph X from 12 noon to 1pm? [1m]

---

- (c) Suggest a possible reason to explain why graph Z was not affected from 12 noon to 1 pm. [1m]

---

~~ END OF PAPER ~~



**SECTION A : (60 MARKS)**

| Qn no. | Ans |
|--------|-----|
| 1      | 3   |
| 2      | 1   |
| 3      | 1   |
| 4      | 4   |
| 5      | 3   |
| 6      | 3   |
| 7      | 4   |
| 8      | 4   |
| 9      | 4   |
| 10     | 4   |

| Qn no. | Ans |
|--------|-----|
| 11     | 1   |
| 12     | 1   |
| 13     | 2   |
| 14     | 1   |
| 15     | 4   |
| 16     | 4   |
| 17     | 1   |
| 18     | 4   |
| 19     | 3   |
| 20     | 2   |

| Qn no. | Ans |
|--------|-----|
| 21     | 2   |
| 22     | 2   |
| 23     | 4   |
| 24     | 1   |
| 25     | 4   |
| 26     | 1   |
| 27     | 4   |
| 28     | 4   |
| 29     | 4   |
| 30     | 3   |

**SECTION B (40 MARKS)**

| Qn No. | Answer                                                                                                                            |
|--------|-----------------------------------------------------------------------------------------------------------------------------------|
| 31a    | No. The frog has only 3 stages in its life cycle, the frog has only eggs tadpoles and then frog                                   |
| 31b    | The life cycle of a housefly has 4 stages and has a pupa stage while the life cycle of a frog has 3 stages and has no pupa stage. |

|         |                                                                                                                                                                               |
|---------|-------------------------------------------------------------------------------------------------------------------------------------------------------------------------------|
| 32a (i) | Grass → grasshopper → spider → crow → eagle                                                                                                                                   |
| (ii)    | Lantana → Snail → Snake → Eagle                                                                                                                                               |
| 32b.    | There are likely to be more caterpillars. The prey must always lot more than the predator to balance the community.                                                           |
| 32c.    | No. The snail is an herbivore and eats only plants. It is also eaten up by the lizard population, so we do not consider as it is both a predator and prey, it is just a prey. |

|      |                                                                   |
|------|-------------------------------------------------------------------|
| 33a  | Harvest will be poor mushrooms grow best in dam and shady places. |
| 33b. | Observation C                                                     |

| Qn No.  | Answers                                                                                            |
|---------|----------------------------------------------------------------------------------------------------|
| 34a.    |                                                                                                    |
| 34b (i) | The stomata were blocked and the exchange of gases could not take place.                           |
| (ii)    | Watervapour do not escape from the leaves. Thus it cannot absorb water and minerals from the soil. |

|      |                                                                                               |
|------|-----------------------------------------------------------------------------------------------|
| 35a  | Skeleton Q has long arm bones and long fingers and leg bones while a human skeleton does not. |
| 35b  | The long fingers help it to hold and catch its prey easily.                                   |
| 35c. | A gorilla                                                                                     |

|     |         |
|-----|---------|
| 36a | Worms   |
| 36b | crab    |
| 36c | Ostrich |
| 36d | bat     |

|         |                                                             |
|---------|-------------------------------------------------------------|
| 37a     | Some of the rubbish collected was recycled.                 |
| 37b (i) | Reduces land pollution by not taking up so much land space. |
| (ii)    | Smoke and slot discharged cause air pollution               |

|     |                                                                                                                     |
|-----|---------------------------------------------------------------------------------------------------------------------|
| 38a | It is limewater                                                                                                     |
| 38b | Decomposition have taken place                                                                                      |
| 38c | She wanted to find out if during respiration the flowers produced carbon dioxide and turns the limewater to cloudy. |

|     |                                                                                                      |
|-----|------------------------------------------------------------------------------------------------------|
| 39a | Gravitational potential energy $\longrightarrow$ kinetic energy $\longrightarrow$ electrical energy. |
| 39b | The generator would spin faster and more electricity would be produced.                              |

|     |                                                  |
|-----|--------------------------------------------------|
| 40a | Solid state to liquid state                      |
| 40b | The temperature remains constant in both process |
| 40c | Heat energy                                      |



| Qn No | Answers                                                                                                                                                                            |
|-------|------------------------------------------------------------------------------------------------------------------------------------------------------------------------------------|
| 41a   | The bulb will not light up.                                                                                                                                                        |
| 41b   | Material B is an insulator of electricity                                                                                                                                          |
| 42a   | Revolution, phases                                                                                                                                                                 |
| 42b   | Position D and F                                                                                                                                                                   |
| 43a   | The colour                                                                                                                                                                         |
| 43b   | When the texture is the same but the colour is different the increase in temperature is greater                                                                                    |
| 43c   | When the copper sheet come into contact with another heat is transferred from one to the other hence the temperature recorded is not the same.                                     |
| 44a   | 60ml to 80ml                                                                                                                                                                       |
| 44b   | When the water reaches the 60ml mark it covers the lower end of the glass tube so air inside the jar cannot escape through the glass tube. As a result water cannot enter the jar. |
| 45a   | C and D                                                                                                                                                                            |
| 45b   | Whether the temperature affects the rate of evaporation.                                                                                                                           |
| 46a   | Y, X                                                                                                                                                                               |
| 46b   | It could have rained                                                                                                                                                               |
| 46c   | It was blacked in an indoor area of the school                                                                                                                                     |