

PRIMARY THREE SCIENCE

SEMESTRAL ASSESSMENT 2
2005

BOOKLET A

Date : 26TH October 2005

Duration : 1 h 45 min

Name : _____ ()

Class: Primary _____ ()

Marks Scored:

Booklet A:		60
Booklet B :		40
Total :		100

Parent's signature:

**DO NOT OPEN THIS BOOKLET UNTIL YOU ARE TOLD TO DO SO.
FOLLOW ALL INSTRUCTIONS CAREFULLY.**

Booklet A consists of 13 printed pages including this cover page.

Section A (30 x 2 marks = 60 marks)

For each question from 1 to 30, four options are given. One of them is the correct answer. Make your choice (1, 2, 3 or 4). **Shade the correct oval (1, 2, 3 or 4) on the Optical Answer Sheet provided.**

1. Man depends on animals in many ways. For examples, animals

- (A) give us oxygen
- (B) help to transport goods
- (C) are a source of food for Man

- (1) A only
- (2) B only
- (3) A and C only
- (4) B and C only

2. Look at the diagram below and answer the following question.

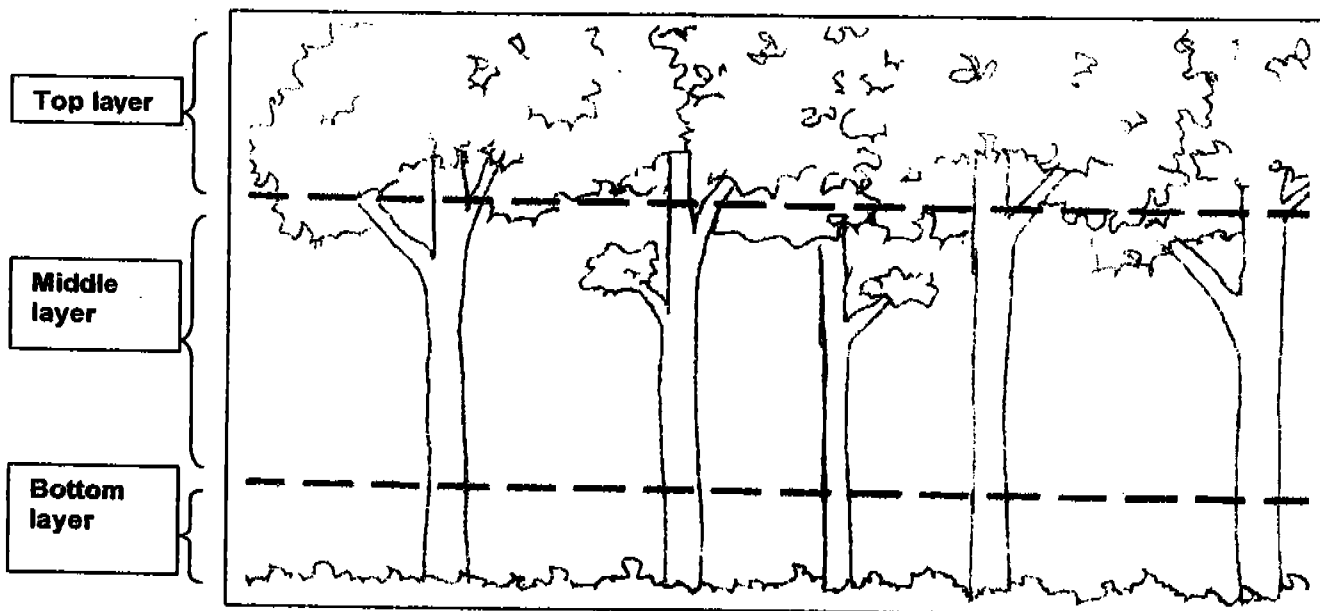

In the rainforest, there is more growth at the top layer because there is/are more _____.

- (1) air
- (2) rain
- (3) sunlight
- (4) nutrients

3. Study the venn diagram below and answer the question.

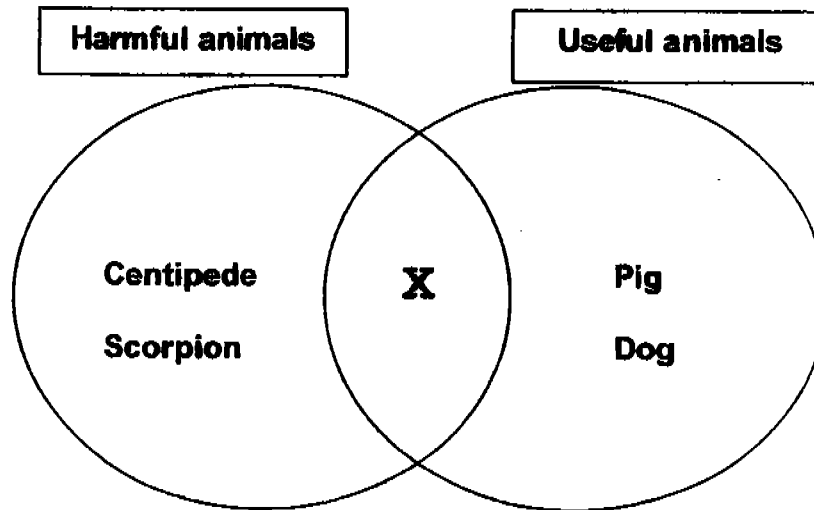

What animal can **X** be?

- (1) cow
 - (2) snake
 - (3) chicken
 - (4) cockroach
4. Jedi noticed different flowers growing on the two papaya plants in the garden. His mother explained that one of the papaya plants bore male flowers while the other one bore female flowers. On closer look, Jedi also noticed that only one of the papaya plants has fruit. Which one of the following statements is true?
- (1) Insects are only attracted to one of the plants.
 - (2) Only the plant that bears male flowers can bear fruits.
 - (3) Only the plant that bears female flowers can bear fruits.
 - (4) One of the plants is receiving more sunlight and nutrients as compared to the other.
5. In what way is the mosquito and toad alike?
- (1) They suck blood.
 - (2) They feed on insects.
 - (3) They spread diseases.
 - (4) They lay eggs in water.

6. Mary is going on a field trip to the Botanical Gardens. Her mother warned her not to touch any of the plants. Which of the following are possible reasons for her advice?

- (A) The plants may have thorns.
- (B) The plants may be poisonous.
- (C) The roots of the plants cannot take in water.

- (1) A only
- (2) A and B only
- (3) B and C only
- (4) A, B and C

7. Study the classification table below carefully.

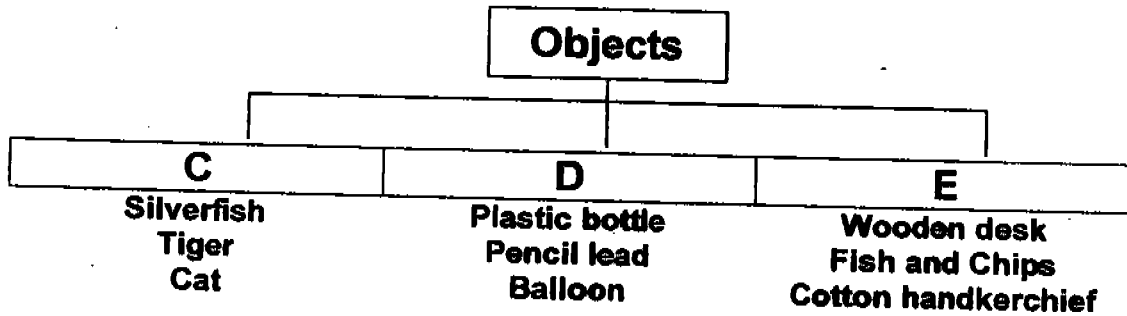

Which of the following headings best represent C, D and E respectively?

	C	D	E
1	Living Things	Non-living Things	Things Once Alive
2	Living Things	Things Once Alive	Non-living Things
3	Things Once Alive	Living Things	Non-Living Things
4	Non-Living Things	Things Once Alive	Living Things

8. Heidi needs to design a toy boat that can float. She wants to use material that is from the nature and once alive. What material should Heidi use for the body of the boat?

- (1) clay
- (2) wood
- (3) wool ball
- (4) styrofoam

9. Which one of the following animals reproduces in the same way as the camel?

- (1) hen
- (2) guppy
- (3) platypus
- (4) kingfisher

Study the flow-chart carefully and answer questions 10 and 11.

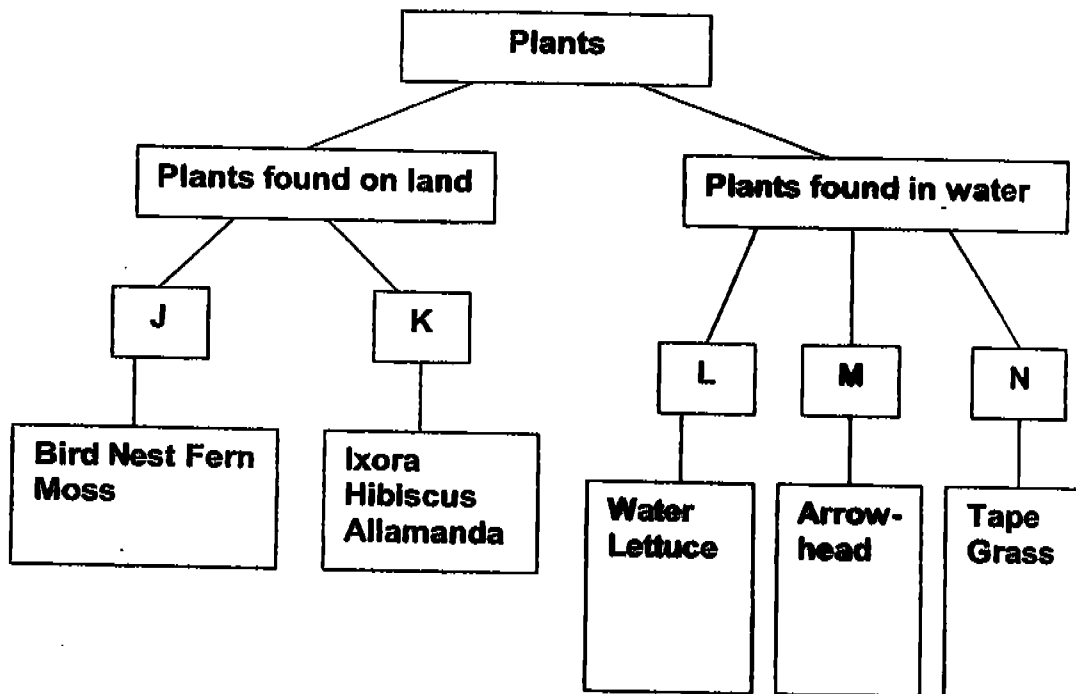

10. A suitable heading for K would be _____.

- (1) Land plants
- (2) Edible plants
- (3) Flowering plants
- (4) Poisonous plants

11. Which of the following represents plants that can be found under the heading L, M and N respectively?

- (1) Cattail, Lotus, Elodea
- (2) Water Hyacinth, Hydrilla, Cattail
- (3) Lotus, Duckweed, Hydrilla
- (4) Duckweed, Lotus, Elodea

12. Micro-organisms can be very useful to humans. Which of the following is/are example(s) of how micro-organisms benefit us?

- (A) Production of bread
- (B) Production of cheese
- (C) Production of cultured milk

- (1) B only
- (2) C only
- (3) A and B only
- (4) A, B and C

13. Study the table below:

X	Y
Horse	Cat
Caterpillar	Shark
Cow	Penguin
Rabbit	Snake

Which of the following are the correct headings for the above classification?

	X	Y
(1)	Mammals	Reptiles
(2)	Plant eaters	Meat eaters
(3)	Animals with 4 legs	Animals with no legs
(4)	Animals that live on land	Animals that live in water

14. Siti says that plants are important as they provide us with oxygen. Her teacher, Miss Tan, agrees and says that plants are more useful than that. Which of the following can be the possible answer?

- (A) plants provide us with food
- (B) plants beautify our surroundings
- (C) plants provide us with materials
- (D) plants provide us with medicine

- (1) A and B only
- (2) C and D only
- (3) A, B and C only
- (4) A, B, C and D

15. Study the table below. Which one of the following is correctly classified?

Useful Plants			
	Provide materials to make furniture	Provide leaves to wrap food	Provide edible stems
1	Coconut	Tomato	Bamboo
2	Teak	Banana	Rubber
3	Bamboo	Banana	Sugar Cane
4	Lotus	Bamboo	Sugar Cane

16. Study the cycle below carefully.

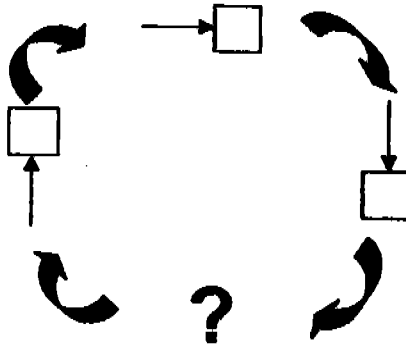

What should appear in place of the question mark?

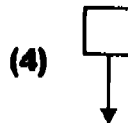
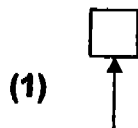

17. Valerie found an egg of a dragonfly. She knew that the life cycle of the dragonfly is similar to that of the cockroach.

Which one of the following stages can be found in the life cycle of the dragonfly?

- (1) pupa
- (2) larva
- (3) nymph
- (4) cocoon

18. Study the life cycle of the mosquito below.

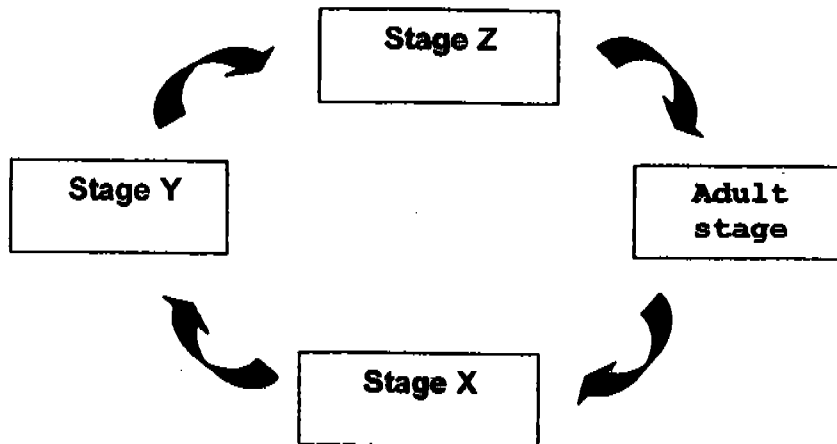

At which stage(s) is/are the movement of the animal very little?

- (1) Y only
 - (2) X and Y
 - (3) X and Z
 - (4) Y and Z
19. Ryan had a pet bullfrog. He learned that this type of bullfrog undergoes an 18-week life cycle as follows:

Stage	Duration for each stage (weeks)
Egg	3
Tadpole	5
Tadpole with legs	3
Froglet	3
Adult frog	4

Ryan studied the development of his pet every day. He first observed legs appearing on the tadpole 4 weeks ago.

How many more weeks from now would it take for his pet to first begin growing into an adult frog?

- (1) 2 weeks
- (2) 3 weeks
- (3) 4 weeks
- (4) 5 weeks

20. Anne, Betty, Charlie and Damon wanted to germinate papaya seeds. They conducted separate experiments by changing the conditions for growth as shown in the table below:

	Is air provided?	Is water provided?	Is warmth provided?
Anne	yes	no	yes
Betty	yes	yes	yes
Charlie	yes	yes	yes
Damon	no	yes	yes

After 3 weeks, each child then made the following recordings:

	Recorded outcomes
Anne	The shoots appeared before the roots appeared
Betty	The shoots appeared before the roots appeared
Charlie	The roots appeared before the shoots appeared
Damon	The roots appeared before the shoots appeared

Which child provided the seeds with the correct conditions needed for germination and recorded the outcome correctly?

- (1) Anne
 - (2) Betty
 - (3) Charlie
 - (4) Damon
21. Jamie loves eating pizzas. What are the 2 sense organs that are most useful in helping him enjoy his food?
- (1) ear and nose
 - (2) brain and tongue
 - (3) nose and tongue
 - (4) brain and nose
22. Below are descriptions of four important body systems. Which one of them best describes the circulatory system?
- (1) Helps the different parts of the body to move.
 - (2) Protects the delicate organs, supports the body and gives it shape.
 - (3) Breaks down the food into simpler substances and absorbs it into the body.
 - (4) Carries food, water, oxygen and carbon dioxide to and from the parts of the body.

23. Both Mr Tan and Sally participated in a Science quiz.

Mr Tan was asked to name the **largest sense organ** in human body.

Sally was asked to name the **sense organ that makes the most use of vibrations** when collecting information.

Which is the correct set of answers?

	Mr Tan's answer	Sally's answer
(1)	skin	ear
(2)	heart	throat
(3)	small intestine	skin
(4)	large intestine	ear

24. In the digestion process, food is broken down into simpler substances. In which part of the body is the **digested food absorbed** into the blood?

- (1) gullet
- (2) mouth
- (3) stomach
- (4) small intestine

25. In which part of the digestive system are **digestive juices** found in the body?

- (A) mouth
- (B) stomach
- (C) small intestine
- (D) large intestine

- (1) A and B only
- (2) C and D only
- (3) A, B and C only
- (4) A, B, C and D

26. Which one of the following statements is **false**?

- (1) Bones are filled with bone marrow.
- (2) A broken bone is known as a fracture.
- (3) The skeleton is made of dead tissue called bones.
- (4) The skeletons of insects can be found on the outside of the body.

27. Which of the below pairs is an example of muscles that are not directly attached to bones in the human body?

- (1) biceps and triceps
- (2) biceps and chest muscles
- (3) leg muscles and stomach muscles
- (4) heart muscles and intestine muscles

28. Constantine's teacher told him that plants help provide oxygen to the surroundings.

After studying the diagrams below, Constantine was puzzled as it appeared to him that plants take in as well as give out oxygen to the environment.

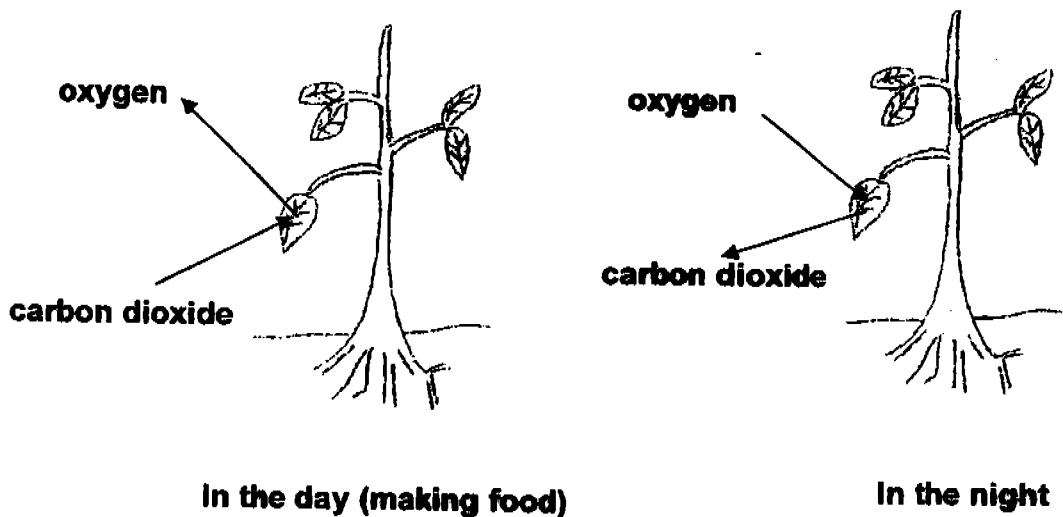

How then do plants actually help provide oxygen to the surroundings?

- (1) Plants give out more oxygen when they are not making food.
- (2) Plants give out a large amount of oxygen at night even when they are not making food.
- (3) During the day, the amount of oxygen given out when making food is more than the amount of oxygen taken in for the whole day.
- (4) During the day, the amount of oxygen given out when making food is less than the amount of oxygen taken in.

29. Study the setups below carefully.
 In Setup A, one end of a bar magnet attracted some paper clips.
 Setup B shows a cracked horseshoe magnet after it was dropped onto the floor.

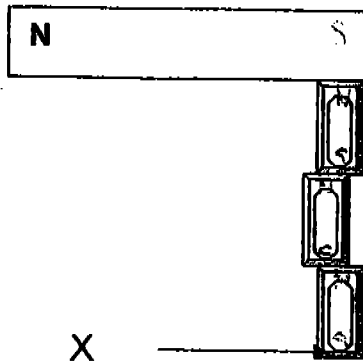

Setup A



Setup B

Which of the following represents correctly the poles at X and Y?

	X	Y
(1)	North	North
(2)	North	South
(3)	South	North
(4)	South	South

30. Emmin was given 2 bars named Bar 1 and Bar 2 as shown below:

Bar 1 X

Bar 2 T

When Emmin placed a magnet close to Bar 1 as shown below, she noticed that the magnet and Bar 1 were attracted to each other:

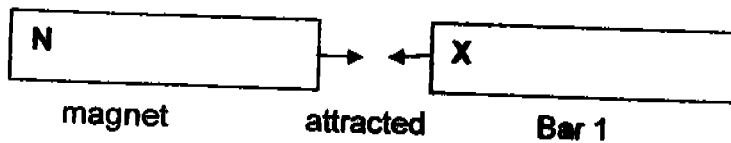

When Emmin placed the same magnet close to Bar 2 as shown below, she noticed that the magnet and Bar 2 repelled each other:

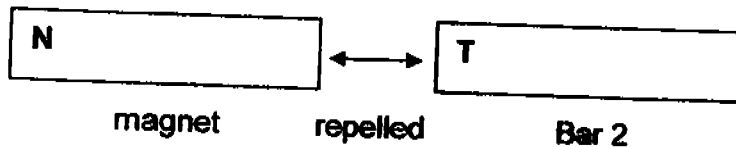

What would happen when she place Bar 1 and Bar 2 close together as shown below?

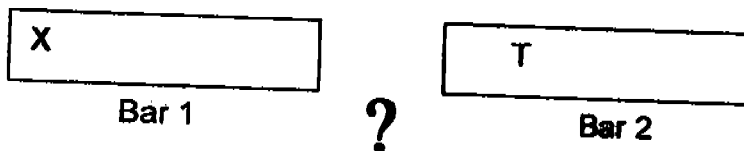

- (A) There may be a repulsion
 - (B) There may be an attraction
 - (C) There will not be an attraction or a repulsion
-
- (1) A only
 - (2) B only
 - (3) C only
 - (4) A and B only

NANYANG PRIMARY SCHOOL

PRIMARY THREE SCIENCE SEMESTRAL ASSESSMENT ² (1) 2005

BOOKLET

Date : 26TH October 2005

Duration : 1 h 45 min

Name : _____ ()

Class: Primary _____ ()

Marks Scored:

Booklet A:		60
Booklet B :		40
Total :		100

Parent's signature: _____

**DO NOT OPEN THIS BOOKLET UNTIL YOU ARE TOLD TO DO SO.
FOLLOW ALL INSTRUCTIONS CAREFULLY.**

Booklet B consists of 12 printed pages including this cover page.

Section B (40 marks)

Write your answers to questions 31 to 46 in the spaces provided.
Marks will be deducted for misspelt key words.

31. Liana used a piece of dry sponge for cleaning dishes. After a few minutes in the water, she noticed that the sponge became heavier. Liana concluded that the sponge was a living thing as it needed water to grow.

Was Liana correct to say that the sponge was a living thing? Why? (2m)

32. a) Give an appropriate heading for i) and ii) below. (1m)
b) Place "crocodile" and "penguin" under the appropriate headings. (1m)

i)	ii)	Bodies covered with hair
Salmon	Peacock	Fox

33. Our science teacher, Mrs Choo, taught us that leaves make food for plants. Andy only noticed spikes and not broad leaves on the cactus plant. He concluded that the cactus plant cannot make food for itself.

(a) Is Andy correct in saying that the cactus plant cannot make food for itself? (1m)

(b) Explain your answer in (a). (1m)

34. State two important properties of the material used to make this product. (2 m)

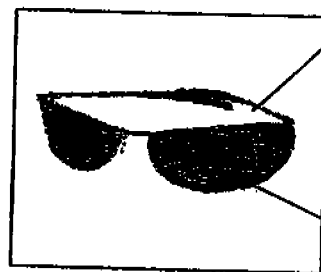

(a)

(b)

35. Dylan was given two different species of fish. He put the different species separately into Jar A and B. Both jars are filled with pond water and both had some hydrilla plants. Dylan then sealed both jars and left them near an open window.

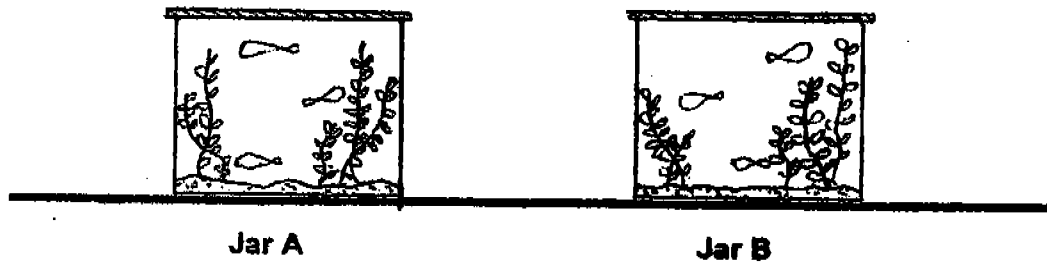

After a week, Dylan observed that in Jar A, the hydrilla were still alive but all the fish had died. In Jar B, both the fish and hydrilla were still alive.

- (a) What could be the reason that all the fish died in Jar A? (1 m)

- (b) Explain 2 ways in which the fish in Jar B had helped the hydrilla to stay alive. (2 m)

- (c) Thinking that it would be too hot to place the fish near the window, Dylan decided to use a piece of black cloth to wrap around Jar B so that the fish would not be exposed to direct sunlight. After a few days, Dylan found that both the fish and plants had died. Explain. (1m)

36. Using the words below, fill in the blanks (a), (b), (c) and (d) with the correct answer. (4 m)

- fern
- rose
- fungus
- hamster

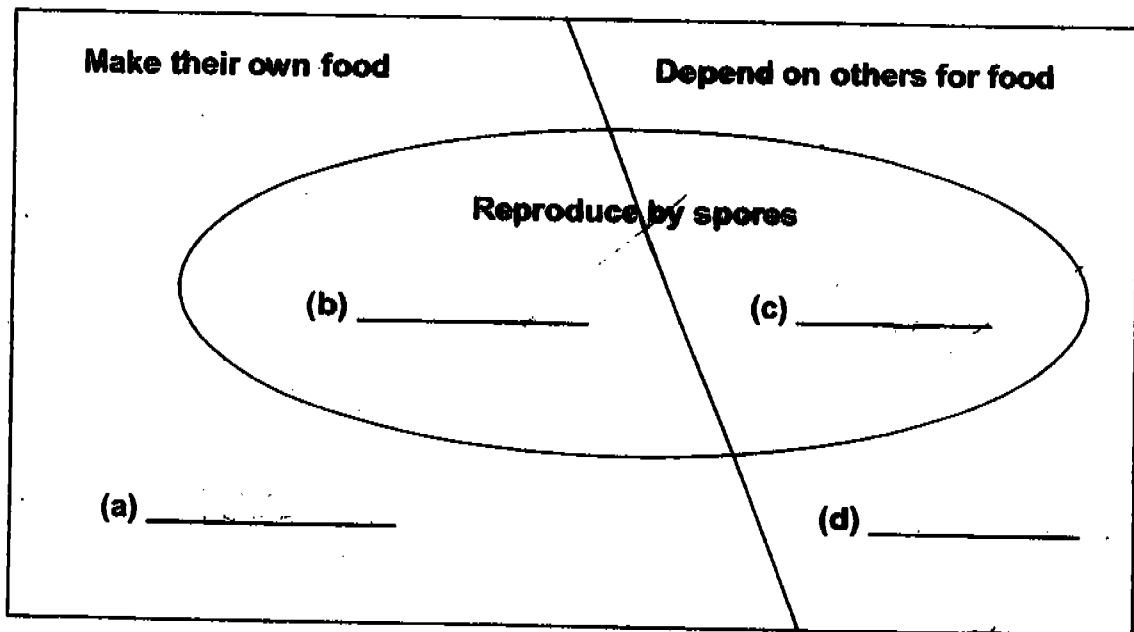

37. Study the flowchart as shown below carefully. Provide suitable headings for (a) and (b) below: (2 m)

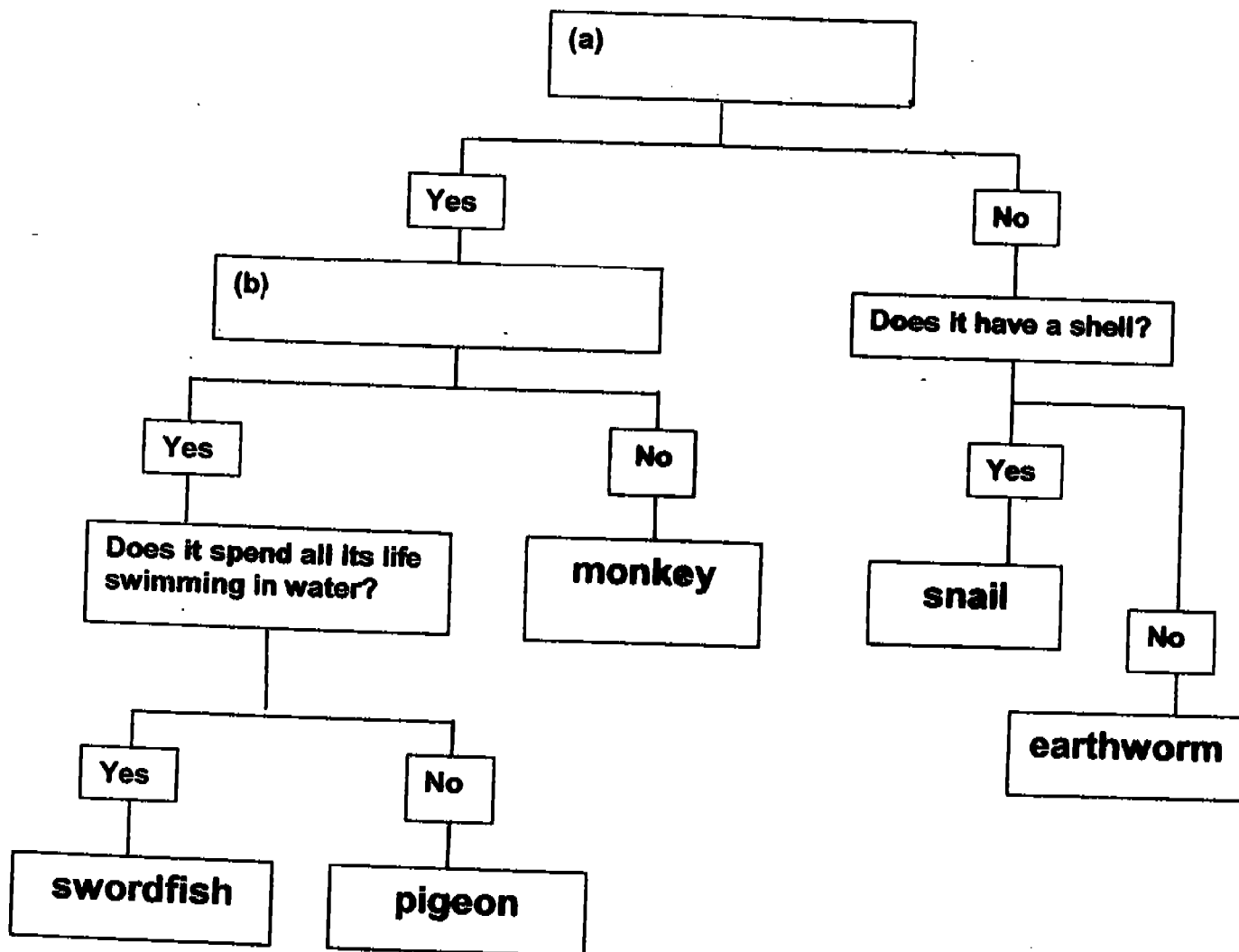

38. Faye cut an onion in the middle as shown in the diagram below. Her brother said that she had just killed the plant and that it would not be able to grow into a new plant.

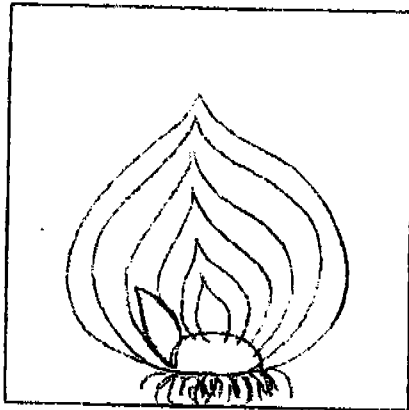

Cut onion

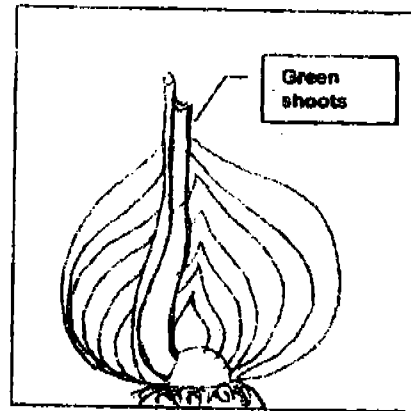

1 week later

A week later, Faye noticed that green shoots were growing out of the onion. How was it possible? (2 m)

39. Write a suitable word in each of the blanks below (2 m)

A cycle is a pattern that a) _____ itself over and over again. The young go through the same life cycle as the b) _____. In this way, living things of the same kind continue to be found on Earth.

40. Study the diagram below carefully.

The letters X, Y and Z represent headings.

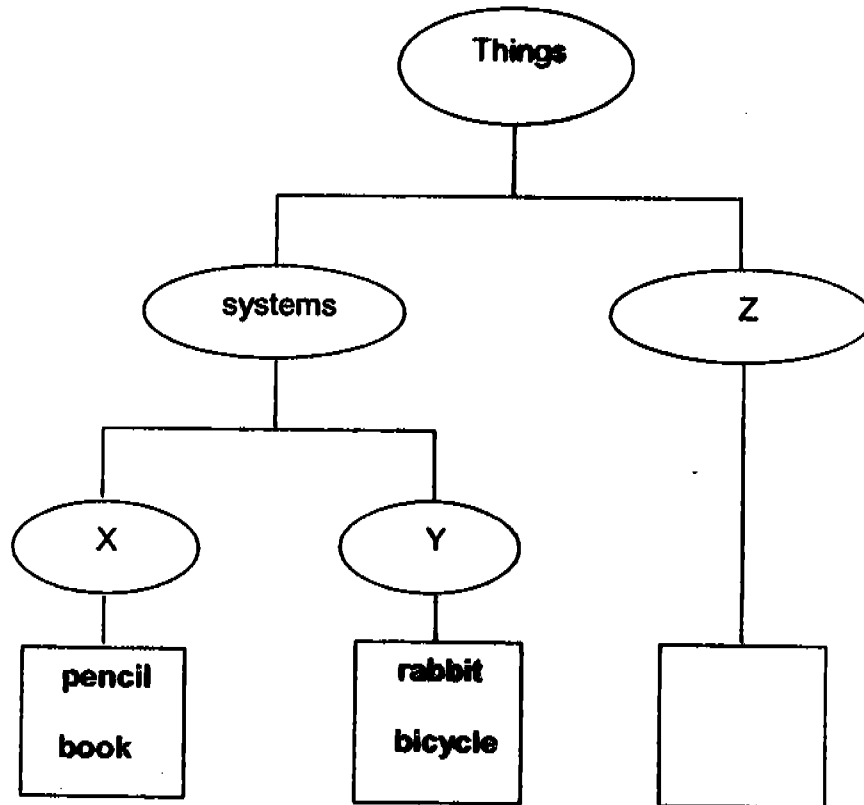

- a) Use a suitable word to represent the heading X. _____ (1m)
- b) Use a suitable word to represent the heading Y. _____ (1m)
- c) Under which letter X, Y or Z should "ant" be placed? _____ (1/2 m)
- d) Under which letter X, Y or Z should "metal ruler" be placed? _____ (1/2 m)

41. A blind man was using a walking stick to cross a busy road. What two senses did he most likely use to help him cross the road?

- a) _____ (1 m)
- b) _____ (1 m)

42. a) What is the name of the muscular tube that squeezes swallowed food into the stomach?

_____ (1 m)

b) In which part of the digestive system is water absorbed from undigested food?

_____ (1 m)

43. Lizam has just learnt that plants make their own food using a green substance.

a) How does the green substance in plants help them make food?

_____ (1 m)

b) What is the process of making food using the green substance known as?

_____ (1 m)

44. Read the statements about the human body in the table below.

Put a tick (✓) in the correct column.

(2 m)

		True	False
(a)	The lower arm bone is the longest bone in the body.		
(b)	Ball and socket joints can be found in the shoulders.		
(c)	The ribcage protects only one important organ.		
(d)	The ankle contains only hinge joints and therefore the ankle can move in circles.		

45. Yueting wanted to find out how the number of turns of wire used will affect the strength of the magnetism produced. She prepared the two set-ups as shown below.

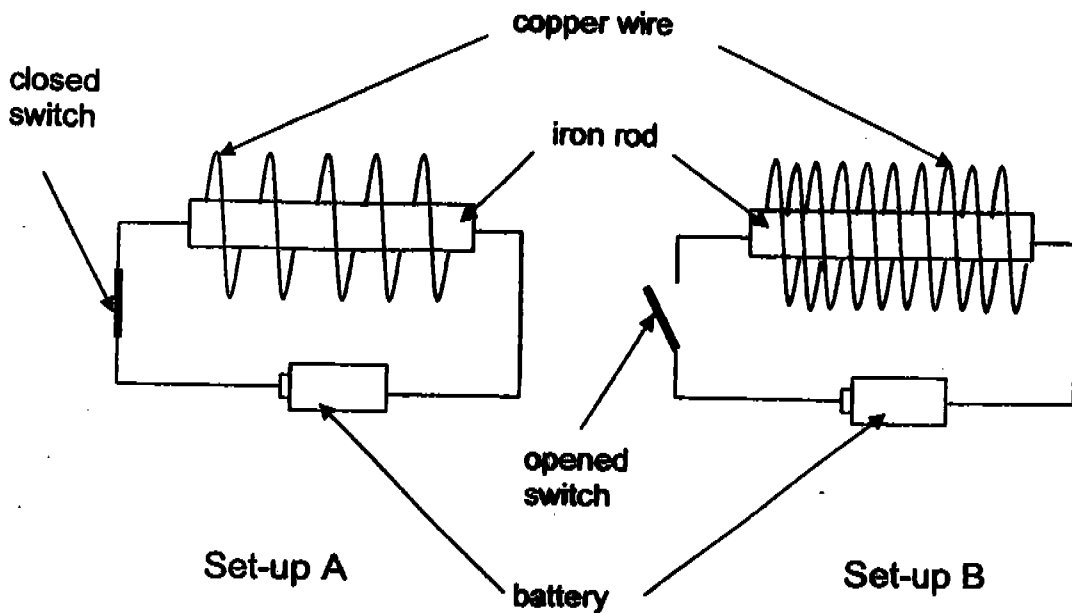

After the five minutes, only the iron rod in Set-up A became warm to the touch.

- a) What had the iron rod in Set-up A become?

_____ (1 m)

- b) What should she do to ensure that the experiment is fair?

_____ (1 m)

- c) After the corrective measure taken in b) had been made to ensure that the experiment was fair, in which set-up would the iron rod attract more paper clips?

_____ (1 m)

- d) Based on the experiment, what would be the proper conclusion to Yueting's experiment?

46. Cindy wanted to find out how the growths of plants were affected by the different amounts of light they received. She used three similar balsam plants and placed them into pots of the same size and labelled them.

Each plant was given the same amount of water for 20 days. Lamps of the same type were used to shine light onto the plants for twelve hours daily. All three plants were placed in the living room and situated far from one another as show in the diagram below:

	Number of lamps directly shining at any one time	The part of the leaves covered with clear masking tape
Plant A	3 lamps	Topside of half of all its leaves
Plant B	2 lamps	Underside of half of all its leaves
Plant C	1 lamp	Underside of half of all its leaves

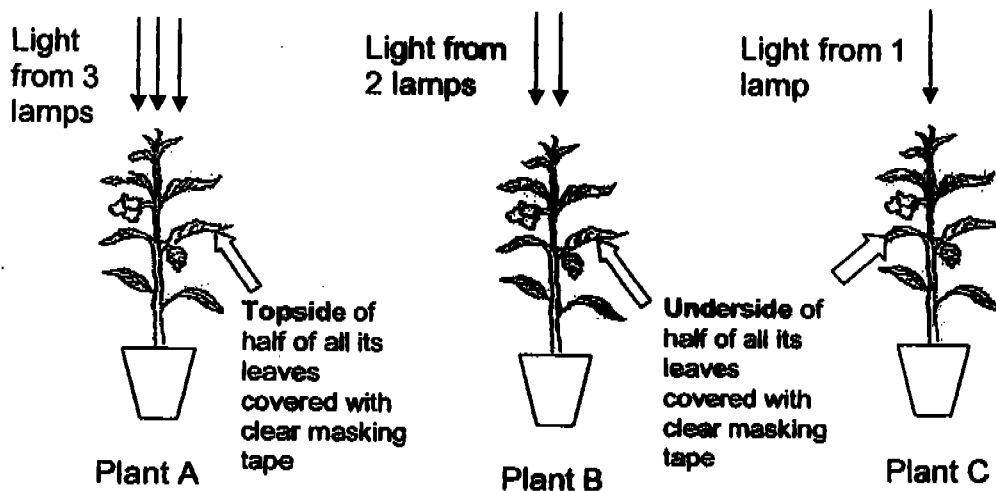

- a) At the end of the 20 days, which two plants should Cindy use for comparing so as to arrive at a fair conclusion?

(2 m)

Cindy then cut the stems of all three plants and found that each stem contained 2 sets of tubes that are of slightly different sizes and of different colourings. The cross-sectional view (view from the top) of the stems are shown below.

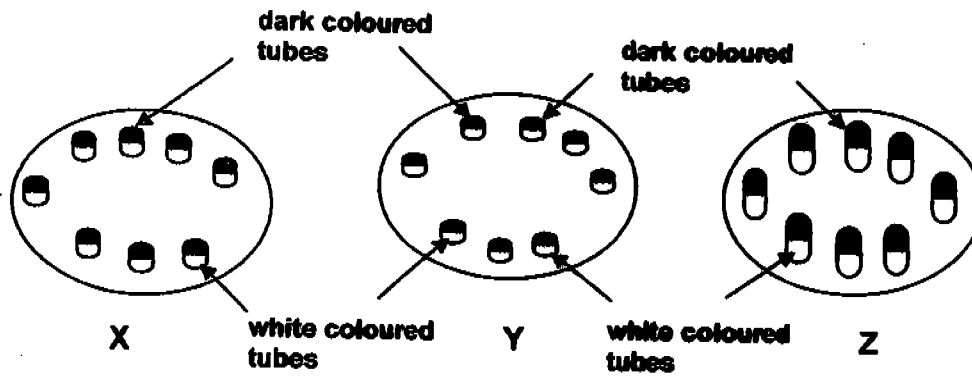

The dark colourings in the tubes represent the amount of food found in each plant.

b) Which diagram X, Y or Z is most likely to be the stem from Plant A?

_____ (1 mark)

-----END OF PAPER-----

Setters: Mrs Mok Pui San and Mr Alfie Wong

SAT

**NANYANG PRIMARY SCHOOL
PRIMARY THREE SCIENCE
SEMESTRAL ASSESSMENT 2
2005**

- 1) 4 27) 4
2) 3 28) 3
3) 2 29) 3
4) 3 30) 4
5) 4 31) No. The sponge absorbed water, caused it
6) 2 to increase in size.
7) 1 32) a) i) Bodies covered with scales
8) 2 ii) Bodies covered with feathers.
9) 2 b) Crocodile penguin
10) 3 33) a) She is not correct
11) 4 b) The steam contains chlorophyll to
12) 4 make food.
13) 2 34) a) stiff b) transparent
14) 4 35) a) It is a carnivorous
15) 3 b) The fish droppings help to keep
16) 3 hydrilla plant alive and the carbon
17) 2 dioxide that the fish was giving out.
18) 3 c) The hydrilla plant died because it
19) 2 needed sunlight and needed the hydrilla
20) 3 plant for oxygen.
21) 3 36) b) fern c) fungus
22) 4 a) rose d) hanster
23) 1 37) a) Does it have a backbone
24) 4 b) Does it lay eggs.
25) 3 38) It has a bud and there are stored food.
26) 3

- 39) a) repels
b) adults
- 40) a) simple
b) complex
c) Y
d) Z
- 41) a) Sense of touch
b) Sense of hearing
- 42) a) The gullet
b) The large intestine
- 43) a) It absorbs sunlight.
b) It is known as photosynthesis.
- 44) a) False
b) True
c) False
d) True
- 45) a) It will be magnetized.
b) Close the switch
c) Set-up B will
d) The more number of turns, the stronger it is.
- 46) a) Plant B and plant C
b) Tube Z is most likely to be the stem from Plant A .