

ANGLO – CHINESE SCHOOL (JUNIOR)

SEMESTRAL ASSESSMENT 2– 2004

SCIENCE

SIAV

PRIMARY THREE

BOOKLET A

Name : _____ ()

Class : PRIMARY 3 ()

Date : 4th November 2004

20 Questions

40 marks



Total time for Booklets A and B : 1 hour and 20 minutes

DO NOT OPEN THIS BOOKLET UNTIL YOU ARE TOLD TO DO SO.
FOLLOW ALL INSTRUCTIONS CAREFULLY.
ANSWER ALL QUESTIONS.

Section A (40 marks)

For each question from 1 to 20, four options are given. One of them is the correct answer. Choose the correct option (1, 2, 3 or 4) and shade the correct oval on the Optical Answer Sheet (OAS).

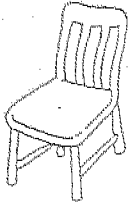
1 Study the 2 groups of things below.

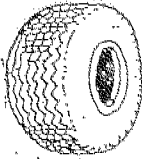
Group A	Group B
	
<p>Butterfly</p>	<p>Wooden chair</p>
	
<p>Girl</p>	<p>Rubber tyre</p>

Which of the following headings for Group A and Group B is correct?

	Group A	Group B
(1)	Animals	Plants
(2)	Living things	Non-living things
(3)	Plants	Animals
(4)	Non-living things	Living things

2 When John tried to catch some fishes in his aquarium with his hand, they swam away. Which characteristics of living things were the fishes showing?

- A Reproduce
- B Move by themselves
- C Need air, water and food
- D Respond to changes around them

- (1) A and B only
- (2) A and C only
- (3) C and D only
- (4) B and D only

3 Ahmad is looking for a T-shirt to wear to his soccer practice. It must be light, cool and able to absorb his perspiration. The T-shirt material that is most suitable is _____.

- (1) wool
- (2) nylon
- (3) cotton
- (4) leather

4 Bird's Nest Fern and Moss are examples of _____.

- (1) fungi
- (2) woody plants
- (3) micro-organisms
- (4) non-flowering plants

- 5 The diagram shows an electromagnet that is used in a rubbish dump.
The electromagnet can be used to separate pieces of _____ from the rest of the rubbish.

- (1) steel and iron
- (2) gold and silver
- (3) copper and lead
- (4) aluminium and tin

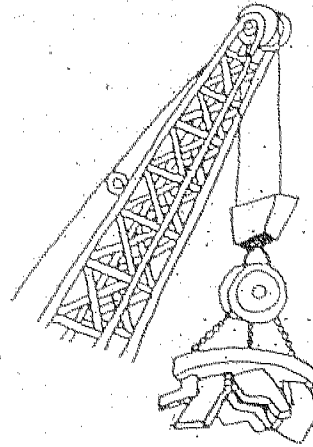

- 6 Lily has inherited some of her mother's features.

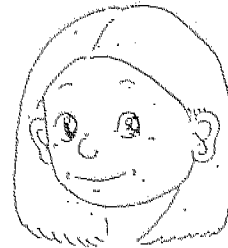
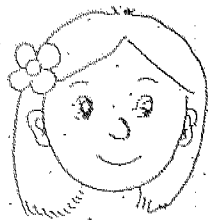

It is not true that Lily has inherited her mother's _____

- (1) eyes
- (2) nose
- (3) length of hair
- (4) ability to roll her tongue

- 7 Ali placed his potted plant in a black box with a small opening on its side. He placed it in the garden. After a week, he observed that the stem had grown towards the small opening.

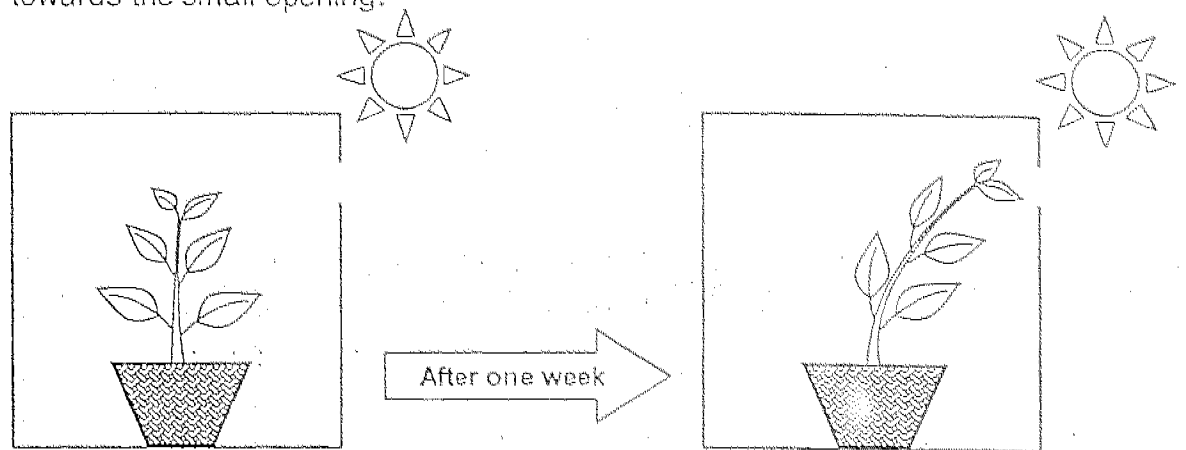

This shows that plants _____.

- (1) respond to water by growing towards it
- (2) need mineral salts and water to survive
- (3) respond to sunlight by growing towards it
- (4) need air, water and warmth to make food

- 8 The flow chart shows how messages are sent to the brain so that a person can decide not to drink sour milk.

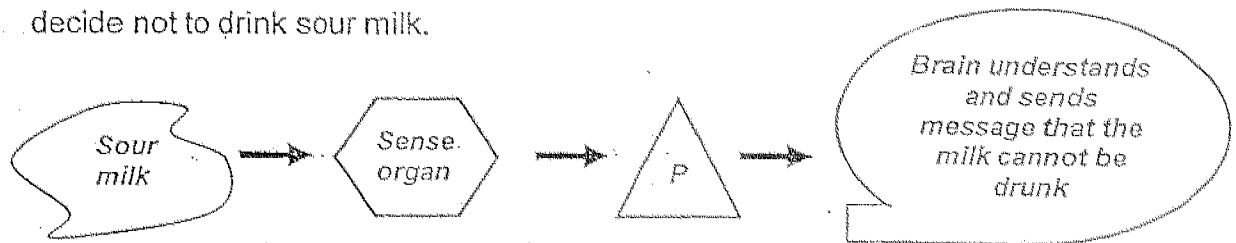

The letter *P* in the flow chart represents _____.

- (1) blood
- (2) nerves
- (3) tongue
- (4) muscles

9 Which of the following shows the life cycle of a butterfly correctly?

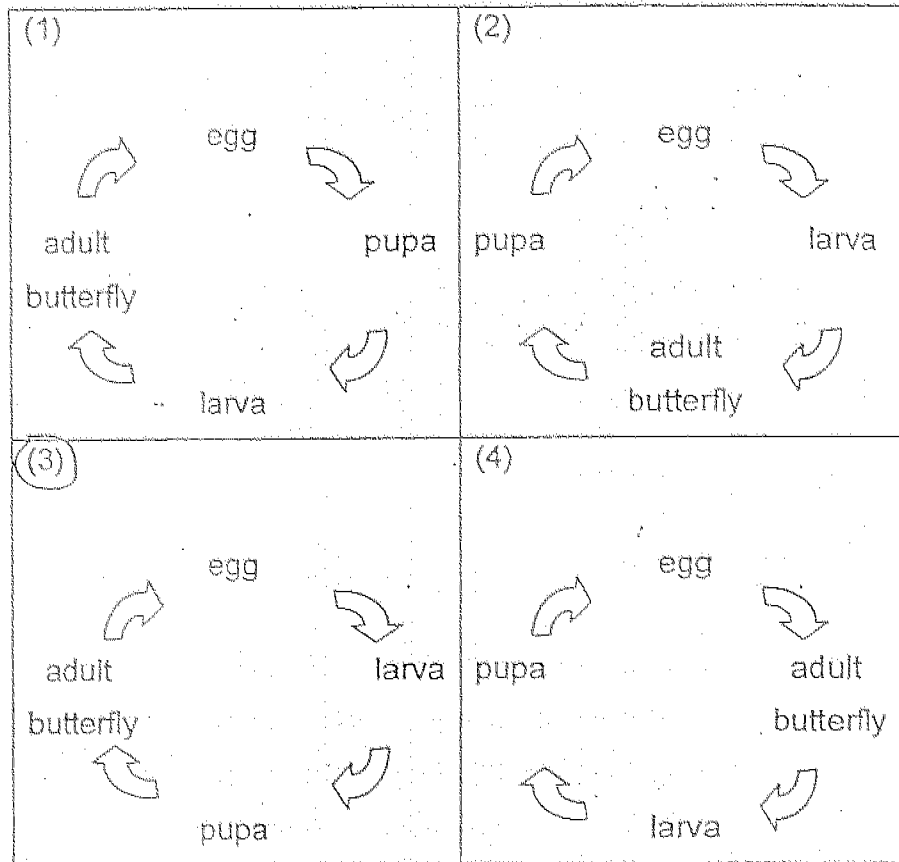

10 In which parts of the digestive system is digestive juices not added to the food?

- A Gullet
- B Mouth
- C Stomach
- D Large intestine

- (1) A and C only
- (2) A and D only
- (3) B and C only
- (4) B and D only

11 Some animals are classified into two groups as shown below.

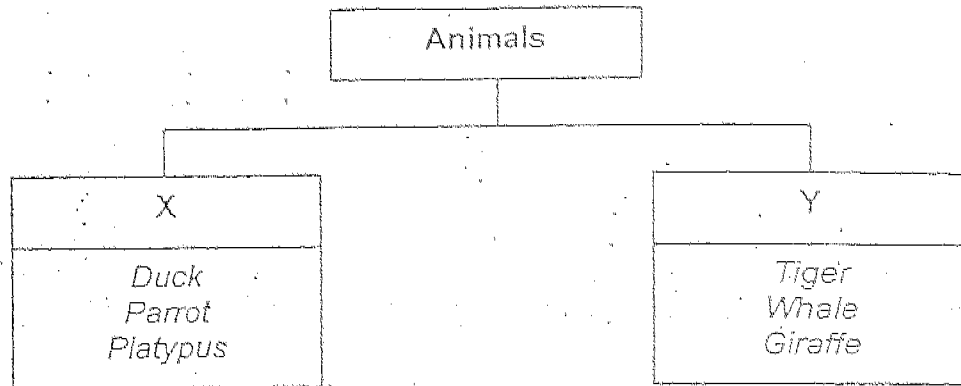

Which of the following is correct?

	X	Y
(1)	Birds	Mammals
(2)	Plant-eaters	Animal-eaters
(3)	Animals that lay eggs	Animals that give birth to live young
(4)	Animals that live in the water	Animals that live on land

12 The diagram shows a fish.

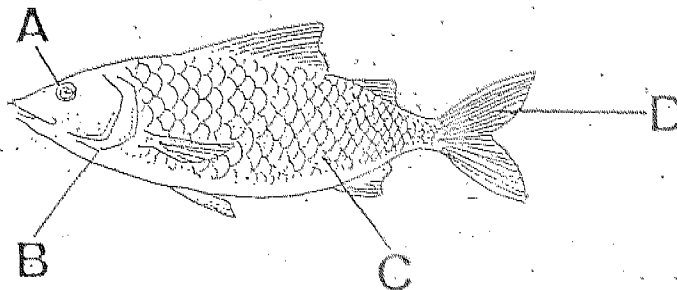

Which part of the fish helps it to move forward?

- (1) A
- (2) B
- (3) C
- (4) D

13 Raju accidentally touched his mother's cactus plant at home. Which sense organ helps him feel the pain?

- (1) Skin
- (2) Ears
- (3) Eyes
- (4) Tongue

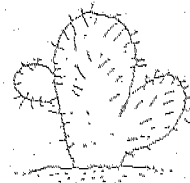

14 Lisa used 2 identical magnets to conduct an experiment. She hung them a short distance above some steel thumbtacks. The result of the experiment is shown in the diagram.

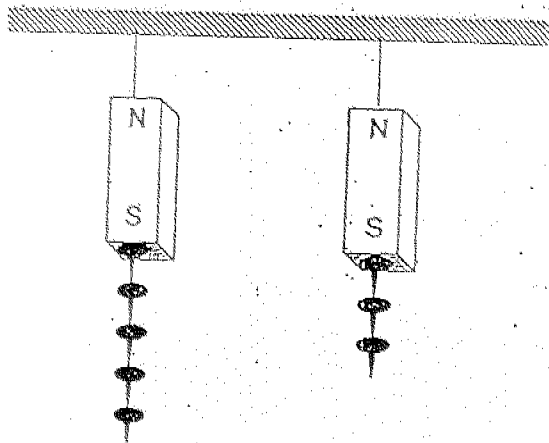

She was trying to find out which _____

- (1) of the bars is a magnet
- (2) of them is a stronger magnet
- (3) parts of the magnets are the strongest
- (4) of them is made from magnetic material

15 David found that by stroking an iron nail with a magnet more times, the nail becomes a stronger magnet. Which of the following actions will cause the same effect on the iron nail if it is made into an electromagnet?

- A Increase the number of batteries
- B Hammering the iron nail several times
- C Increase the number of coils around the iron nail

- (1) A and B only
- (2) A and C only
- (3) B and C only
- (4) A, B and C

16 What is the function of the plant part X shown in the diagram.

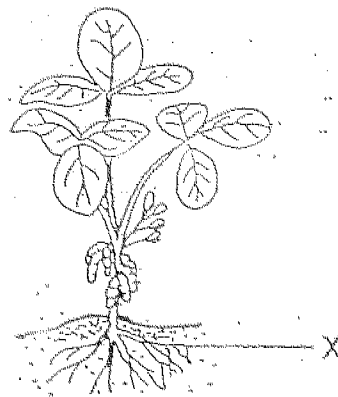

- A Protect the seeds inside it
- B Hold the plant firmly to the ground
- C Absorb water and dissolved mineral salts

- (1) A only
- (2) A and B only
- (3) B and C only
- (4) A, B and C

- 17 Karen held a bar magnet above a paper clip tied to a weight by a string. The magnet pulled the paper clip up. When she placed a sheet of paper between the magnet and the clip, the clip remained where it was. When she placed an iron sheet at the same place, the clip dropped to the ground.

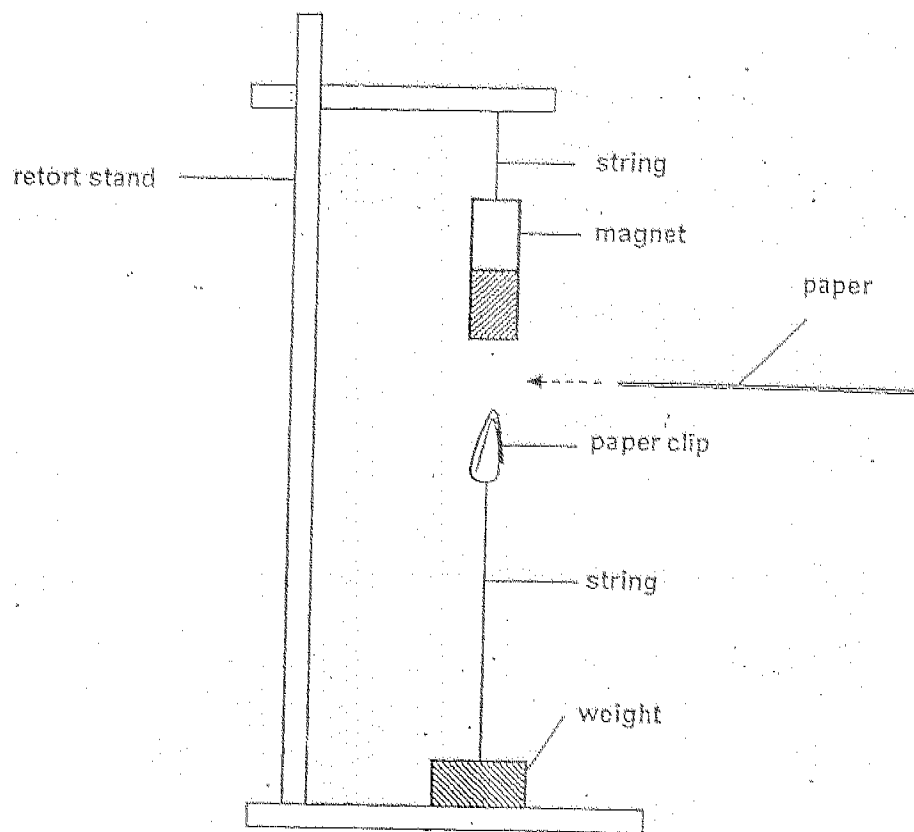

Which of the following statements is correct?

- (1) The paper clip was magnetised.
- (2) The sheet of paper was magnetised.
- (3) Magnetic force can pass through the sheet of paper but not the iron sheet.
- (4) Magnetic force can pass through the iron sheet but not the sheet of paper.

18 Which of the following objects make use of magnets?

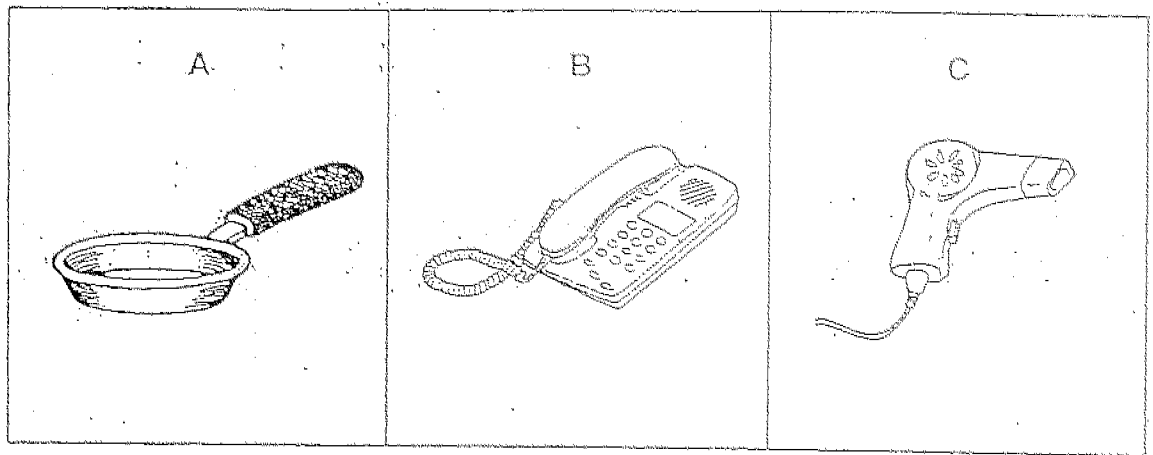

- (1) A and B only
- (2) A and C only
- (3) B and C only
- (4) A, B and C

19 The diagram below shows the muscles and bone of the arm.

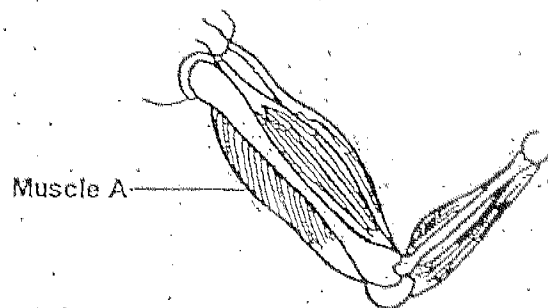

When the arm is straightened, what happens to Muscle A?

- (1) It swings.
- (2) It relaxes.
- (3) It contracts.
- (4) It lengthens.

- 20 Nazri placed some thumbtacks near a horse shoe magnet. The number of thumbtacks attracted to the different parts of the magnet is shown in the table below.

Position	Number of thumbtacks
R	11
S	7
T	1
U	3

Which of the following is the likely position of R?

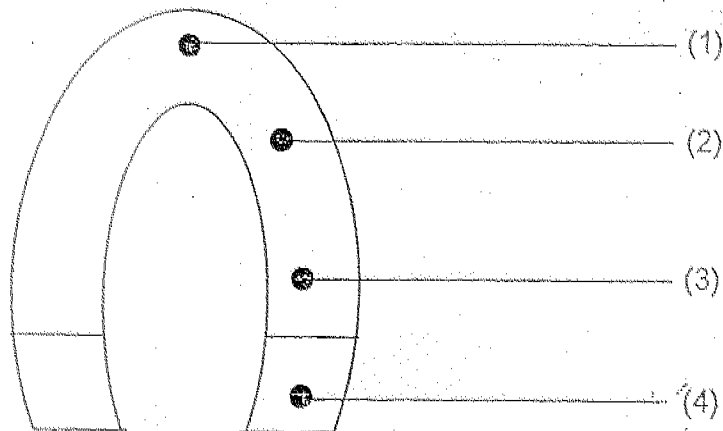

Section B (50 marks)

Write your answers to questions 21 to 38 in this booklet.
Fill in the blanks with the correct answers.

- 21 The graph below shows the height of a young plant which was recorded every 2 days over a period of 8 days.

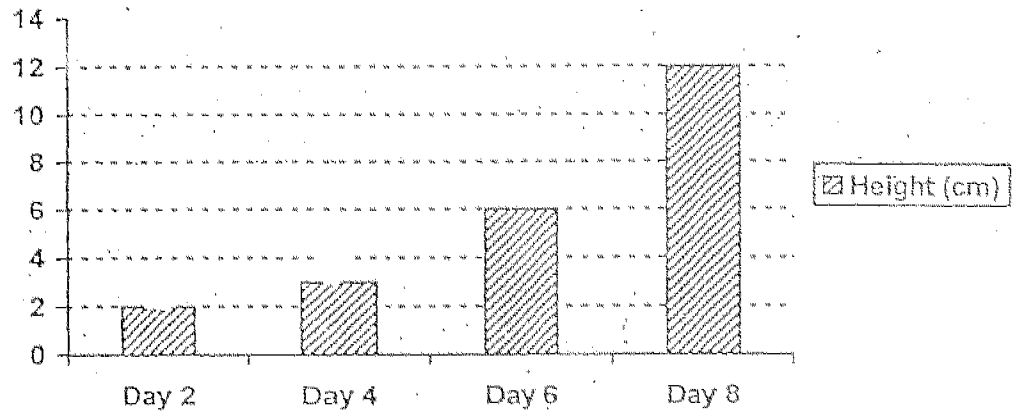

- (a) What was the difference in the height of the plant from Day 4 to Day 8? [1]

- (b) The graph tells us that a living thing can _____ [1]

22. Fill in each blank with a suitable word. [3]

All living things produce their own kind. Ducks lay _____ which will hatch into ducklings and durian trees produce durians which have _____ that will grow into young durian trees. The young will have a _____ life cycle as the parent. This repeating pattern ensures that there will be living things of the same kind around.

--

23 The diagram shows a classification table for living things.

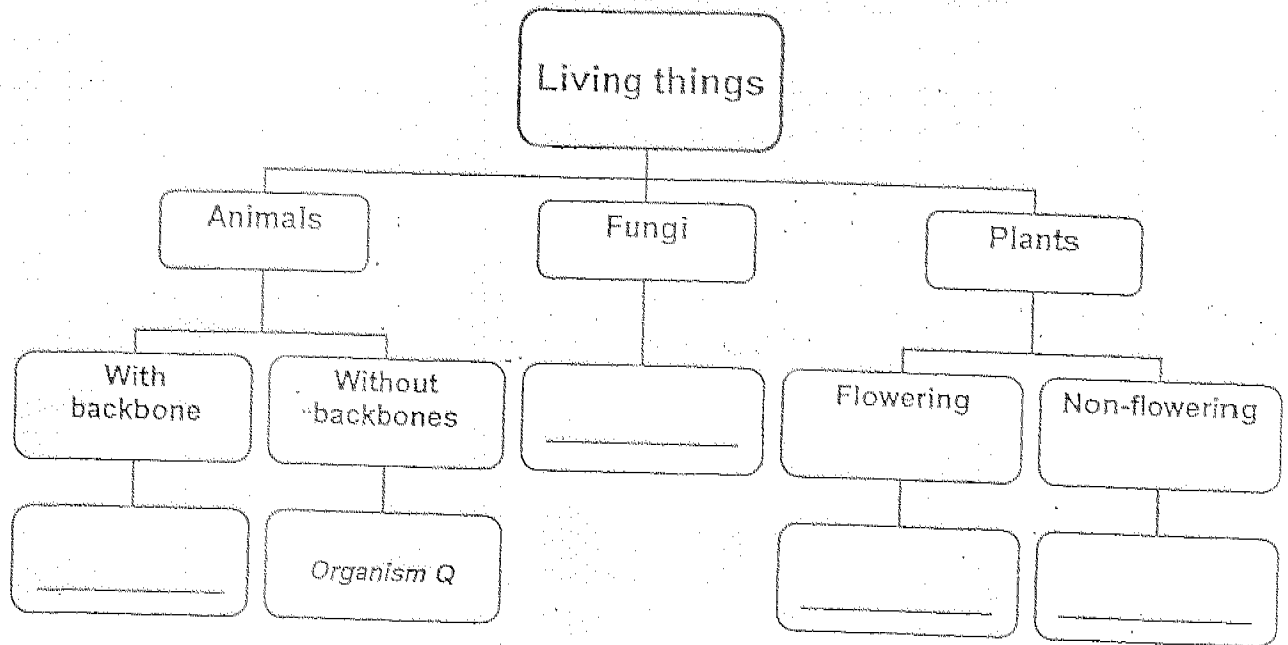

(a) Write "*mushroom*" and "*orchid*" in the correct boxes in the classification table.

[2]

(b) Give an example of Organism Q.

[1]

- 24 Fred conducted several tests on materials P, Q and R to find out the properties of each material. He recorded the results in the table below.

Property	Material P	Material Q	Material R
Allows light to pass through	No	No	Yes
Breaks when dropped	No	No	No
Waterproof	Yes	No	Yes
Hard	Yes	Yes	Yes

- (a) Which is the best material for making window panes? [1]

- (b) Why is this material suitable? [1]

- (c) Circle the object which is most likely to be made of Material P. [1]

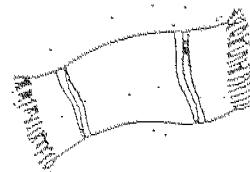
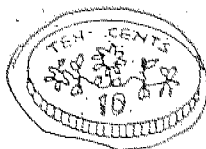

- (d) Wood is an example of Material _____ [1]

25 The diagram shows the stages in the growth of a string bean plant.

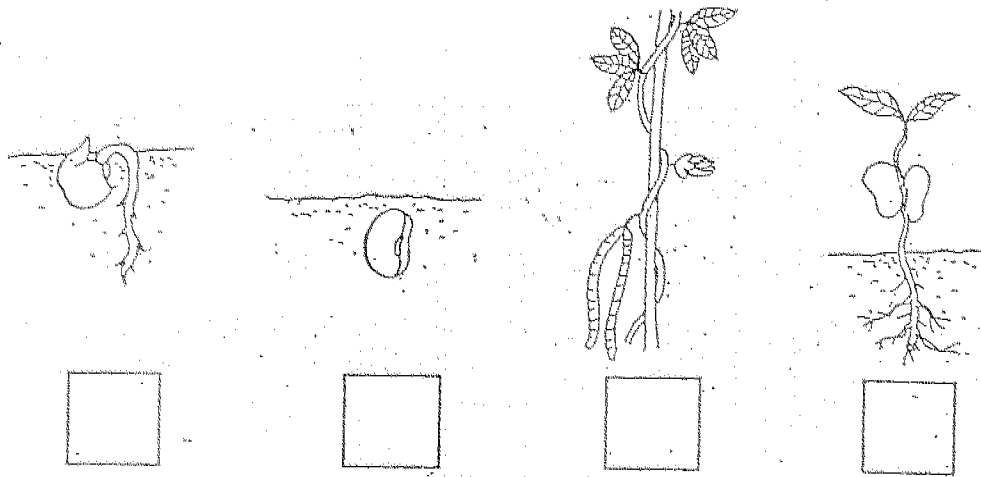

(a) Number the boxes to show the correct order of its growth. [1]

(b) What can flowers develop into? [1]

(c) What does a seed need before it can germinate into a seedling? [1]

26 Draw lines to match the functions to the different systems in the human body. [3]

Takes in oxygen and removes carbon dioxide from the body.

Breaks down food and absorbs them into the body.

Carries food, water and oxygen to all parts of the body.

Circulatory System

Respiratory System

Digestive System

27. The table gives information on three animals, X, Y and Z. A tick (✓) shows that the animal has that characteristic.

	Animal X	Animal Y	Animal Z
Lays eggs in water	✓		✓
Lays eggs on land		✓	
Young resembles adult		✓	✓

- (a) Identify the following animals by writing X, Y or Z in the spaces provided. [2]

Goldfish _____

Mosquito _____

- (b) What are the characteristics of Animal Y? [1]

- (c) Circle the animal that could be Animal Y. [1]

Mealworm Beetle	Hen	Rabbit
Cockroach	Dolphin	

28 The diagram shows the life cycles of two animals. Compare them and write down one similarity and two differences in the boxes below.

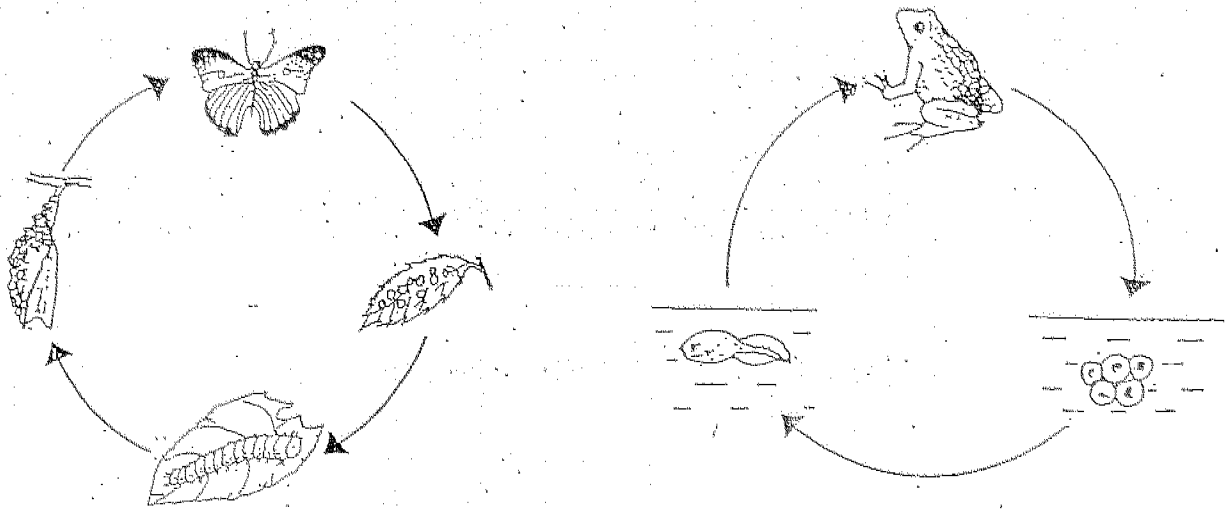

Write one similarity

[1]

Differences with regard to:

Place the eggs are laid

[1]

Number of stages

[1]

29. The diagram shows two similar potted plants. All of the leaves of Plant A are covered with thick pieces of cardboard. Both plants are given the same amount of water and placed in the garden.

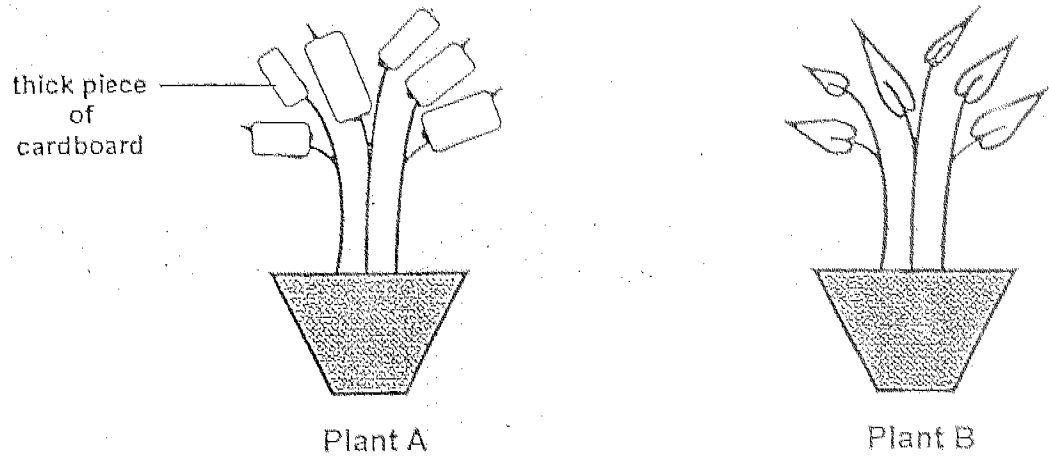

- (a) After two weeks, Plant B was healthy and had many leaves. Will Plant A be the same? Describe what will happen to Plant A after two weeks. [2]

- (b) What does this show? [1]

- (c) When a plant breathes, it takes in _____ and gives out _____ [1]

30 The diagram shows a balsam plant.

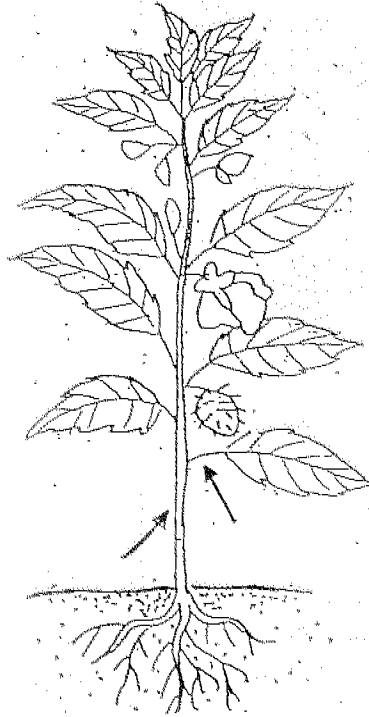

(a) In the diagram, label the part that supports the branches and the leaves. [1]

(b) What is the function of the balsam fruit? [1]

--

- 31 (a) Complete the table by writing down the sense organs which would be most useful in identifying the following situations/objects? [2]

Situation/Object	Sense Organ
A telephone ringing	
A sour fruit	
Cold water	
Pink flowers	

- (b) Explain why the sense of hearing is most useful to a bat flying in a cave. [1]

- 32 Classify the following metals in the table below. [2]

<i>Aluminium</i>	<i>Iron</i>	<i>Tin</i>	<i>Copper</i>	<i>Steel</i>
------------------	-------------	------------	---------------	--------------

Magnetic Materials	Non-magnetic Materials

33 The diagram shows one of our body systems.

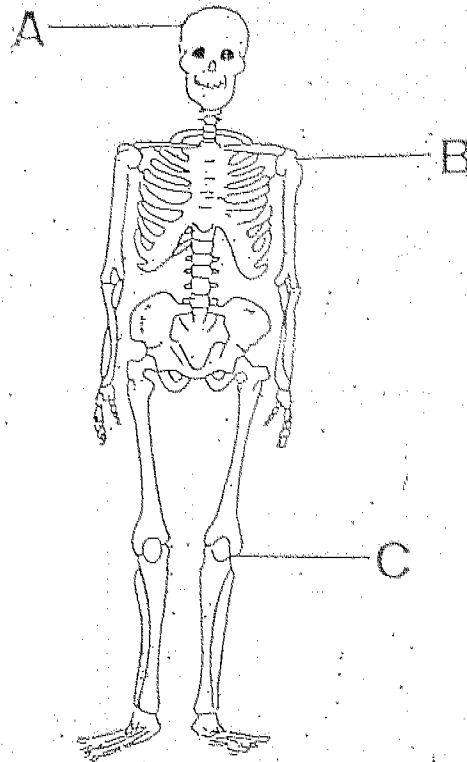

(a) What is the function of the part labelled A?

[1]

(b) State one difference in the functions of the joints labelled B and C.

[1]

34. The diagram shows a shape formed by four bar magnets placed together. The North pole of the first magnet is indicated by the letter 'N'.

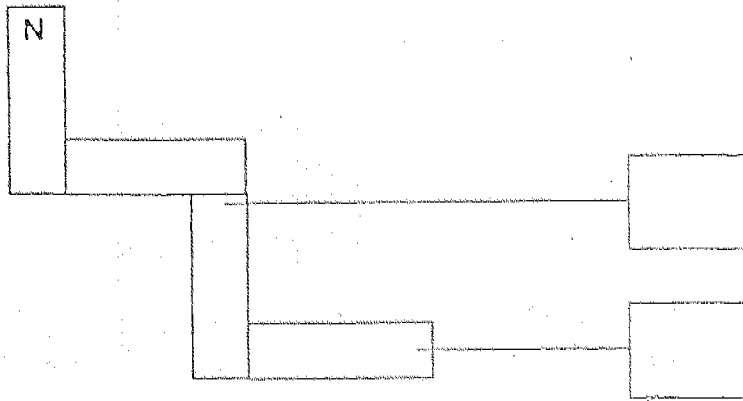

- (a) In the diagram, identify the poles of the third and fourth magnets by writing 'N' for North pole or 'S' for South pole in the correct boxes.

[1]

Later, two of the magnets were removed and replaced by iron bars of the same size.

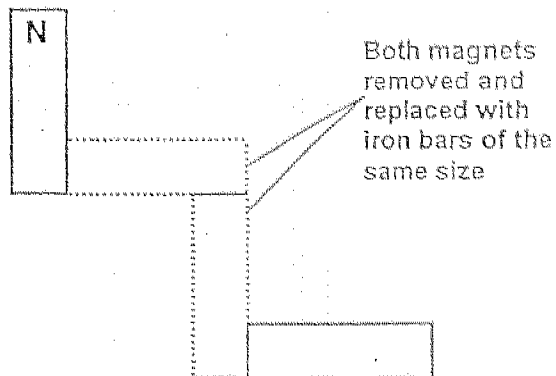

- (b) What would happen to the shape formed by the iron bars and the remaining magnets now?

[1]

35. Salleh was given a bar magnet and told to remove the iron nails from the tin container without pouring out or touching the oil.

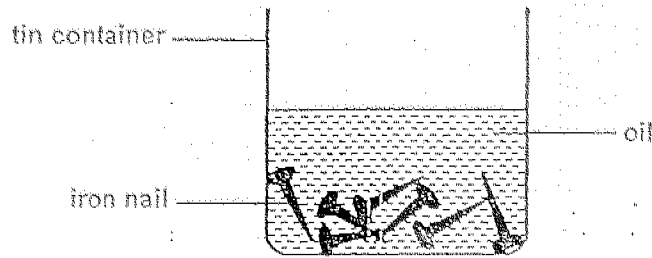

- (a) Would Salleh be able to do it? Explain the answer. [2]

- (b) What would happen if a plastic container was used instead of the tin container? [1]

36. Tim stroked an iron nail with a magnet in one direction a few times and found that it could attract a few paper clips.

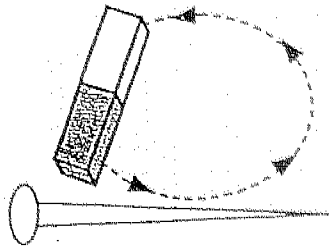

- (a) Without using any other objects or materials, what could Tim do if he wanted the iron nail to attract more paper clips? [1]

- (b) Describe one method he could use to demagnetize the iron nail. [1]

--

37. The diagram shows two ring magnets, A and B, 'floating' above Magnet C which is resting on a wooden base.

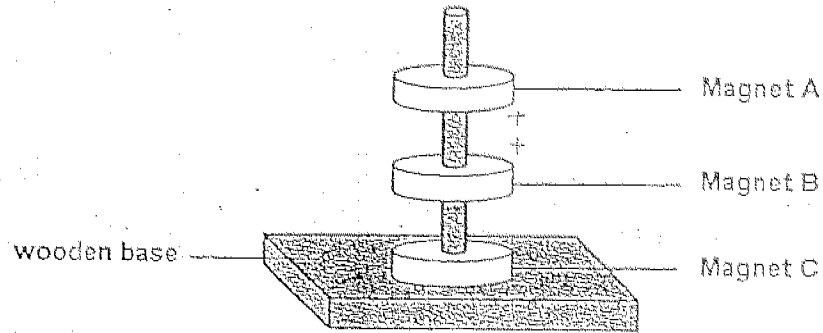

- (a) Why does Magnet A appear to 'float' above Magnet B? [1]

- (b) What should be done to the magnets so that all of them are attracted to one another and resting on the wooden base? [1]

--

38

Devi coiled a wire round a wooden ^{pencil} ruler and connected the ends of the wire to a battery.

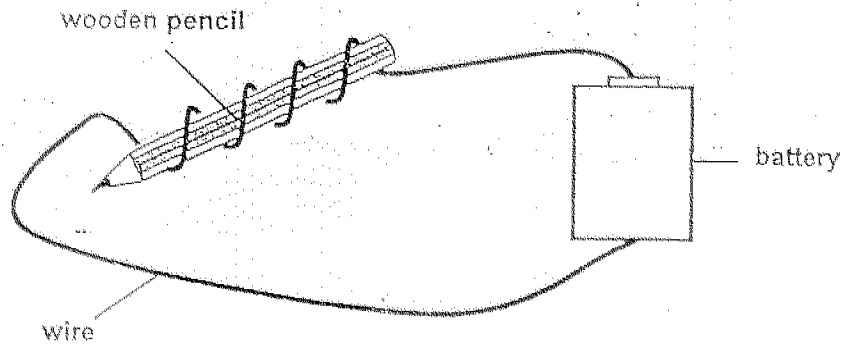

- (a) Will the wooden pencil become a temporary magnet? Why? [2]

- (b) Name an object that can be used instead of the pencil so that it can become an electromagnet. [1]

End of Paper

ANGLO CHINESE SCHOOL (JUNIOR)
SEMESTRAL ASSESSMENT 2 - 2004
PRIMARY THREE SCIENCE

SAL

- | | |
|---------|-------|
| 01. 2 | 11. 3 |
| 02. 4 | 12. 4 |
| 03. 3 | 13. 1 |
| 04. 4 | 14. 2 |
| 05. 1 | 15. 2 |
| 06. 3 | 16. 3 |
| 07. 3 | 17. 3 |
| 08. (2) | 18. 3 |
| 09. 3 | 19. 3 |
| 10. (2) | 20. 4 |

21) a) 9 c.m. b) grow by itself.

22) eggs
seeds
similar

23) mushroom
orchid

b) Molluscs

24) a) Material R

b) Material R is suitable to make window panes because it allows light to pass through.

c) Circle ten cents coin.

d) Q

25) a) 2 1 4 3 b) Flowers would develop into fruits.

c) Air, water and warmth.

26)

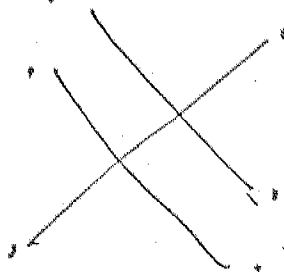

27) a) Z

X

b) It lays eggs on land and its young resembles the adult.

c) Circle hen

28) They both lay eggs

- 29) a) No. Plant A would die after two weeks because it cannot make food for itself without oxygen.
- b) The plant needs sunlight to make food.
- c) oxygen

carbon dioxide

30) a)

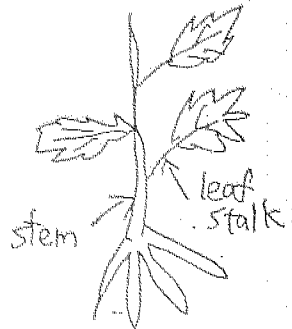

- b) It helps the plant to reproduce.

- 31) a) Ears
Tongue
Skin
Eyes

b) It will not be easy to see in a dark cave, so its sense of hearing would be useful to know where it is going.

- 32) Iron Aluminium
Steel Tin
 Copper

33) a) It helps to protect your brain.

b) Allow our arms and legs to move back and forth in one direction.

34) a) N

S

b) The shape will remain the same.

35) a) Yes. If Salleh puts the magnet close to the oil, the magnetic irons would be attracted to the magnet and out of the tin container.

b) The same thing that happened in (a).

36) a) Stroke the iron nail a few more times.

b) Heat it with fire.

37) a) The same poles are facing each other.

b)