



2009 Graphic Communication

Standard Grade – General

Finalised Marking Instructions

© Scottish Qualifications Authority 2009

The information in this publication may be reproduced to support SQA qualifications only on a non-commercial basis. If it is to be used for any other purposes written permission must be obtained from the Question Paper Operations Team, Dalkeith.

Where the publication includes materials from sources other than SQA (secondary copyright), this material should only be reproduced for the purposes of examination or assessment. If it needs to be reproduced for any other purpose it is the centre's responsibility to obtain the necessary copyright clearance. SQA's Question Paper Operations Team at Dalkeith may be able to direct you to the secondary sources.

These Marking Instructions have been prepared by Examination Teams for use by SQA Appointed Markers when marking External Course Assessments. This publication must not be reproduced for commercial or trade purposes.

**2009 Graphic Communication SG General
Marking Instructions**

1	(a)	(i)	Plan A	Floor						KI 1
		(ii)	B	Sinktop	C	Socket				
			D	Switch	E	Lamp				
			F	Wash Basin	G	Shower Tray				KI 6
	(b)	(i)	Plan B	Location, Block						
		(ii)	Scale	1:1250						
		(iii)	Symbol X	North						KI 3
	(c)	(i)	Plan C	Site						KI 1

TOTAL KI 11

2	Sign Type	Warning	Border Colour	Black						
			Background Colour	Yellow						
	Sign Type	Safe Condition	Background Colour	Green						
	Sign Type	Prohibition	Border Colour	Red						
			Background Colour	White						
	Sign Type	Mandatory	Background Colour	Blue						KI 7

TOTAL KI 7

3	(a)	Command:	Array							
		Command:	Fillet, Trim Round							
		Command:	Rotate							
		Command:	Hatch							
		Command:	Ellipse							
		Command:	Circle							KI 6
	(b)	Device:	Plotter (any type)							
		Device:	Inkjet Printer, Laser Printer							KI 2
	(c)	Explanation:	To make an extra copy of data or files, stored on a separate device.							
		Reason:	In case the data or files get lost, deleted or corrupted.							KI 2

TOTAL KI 10

- 4 (a)** View A: Oblique
View B: Isometric
View C: Planometric KI 3
- (b)** Answer 1: 1 pt perspective
Answer 2: 2 pt perspective, 3 pt perspective KI 2
- (c)** 45 degrees KI 1
- (d)** Pictorial KI 1

TOTAL KI 7

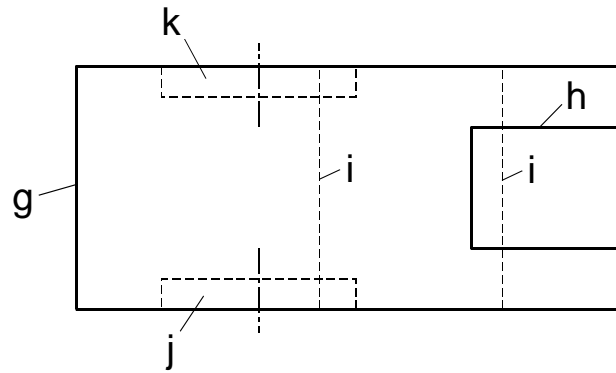

PLAN

Question 5

Plan

- (g) Width (as end elevation)
- (h) Width 20 + pos + length
- (i) Broken lines
- (j) Length + depth 5
- (k) Length + depth 5

DA 5

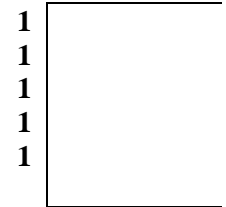

End Elevation

- (a) Width 40
- (b) Broken lines (3 at 1 mark each)
- (c) Width 30 + position
- (d) Width 20 + position
- (e) Depth 5 (height correct)
- (f) Depth 5 (height correct)

DA 8

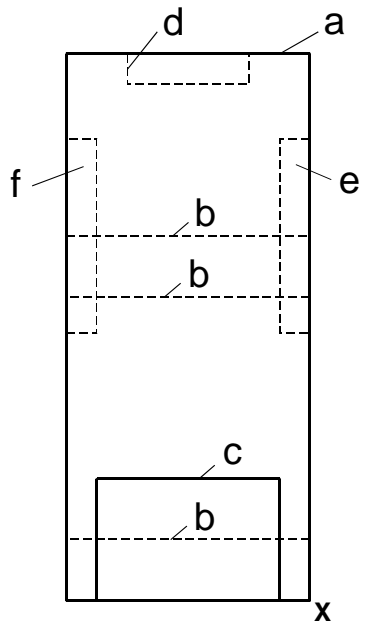
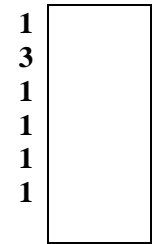

Question 6

- (a) Length of crate 1
- (b) Height of crate 1
- (c) Width of crate 1
- (d) Material thick. (5 out of 8) 1
- (e) Height to shelf 1
- (f) Position (length 1 width 1) 2
- (g) Length 1
- (h) Height to shelf 1
- (i) Lines shown (3 lines) 1
- (j) Lines shown (2 lines) 1

DA 11

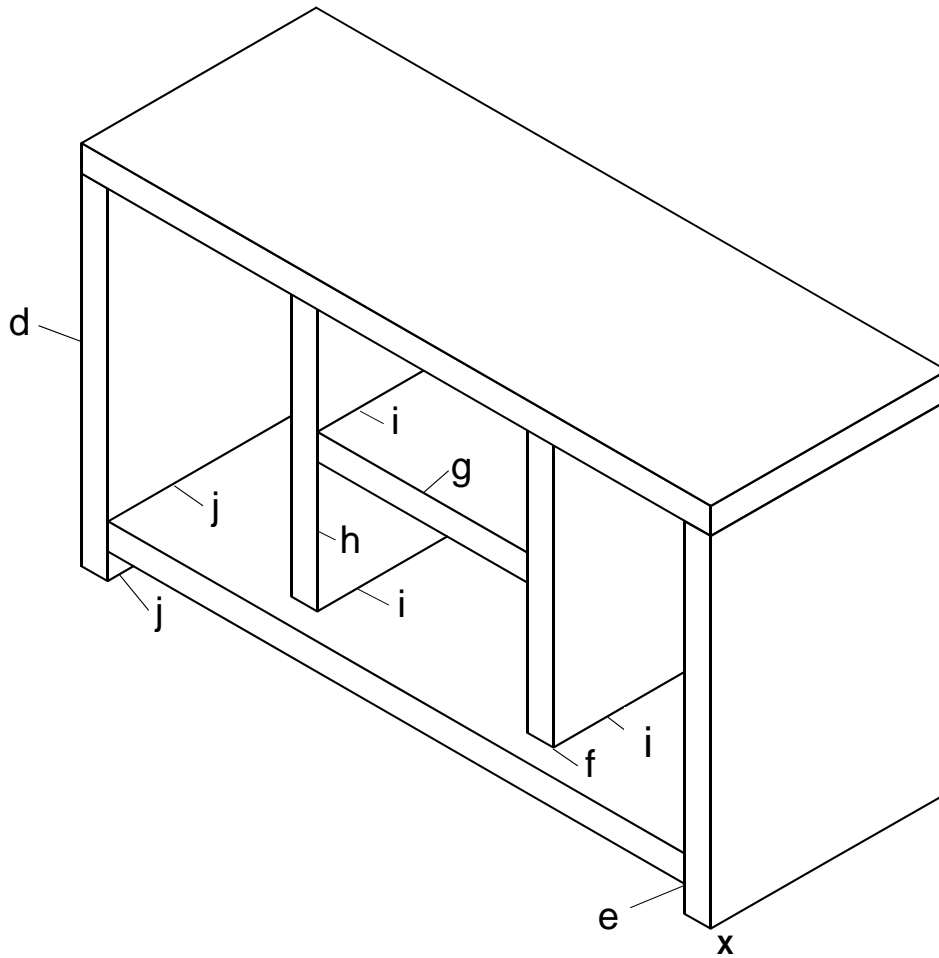
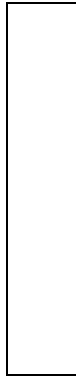

ISOMETRIC VIEW

Question 7

End Elevation

- (f) Base Width 1
- (g) Apex Position correct 1
- (h) Sloping Lines 1
- (i) Cut Surface (correct height) 1

DA 4

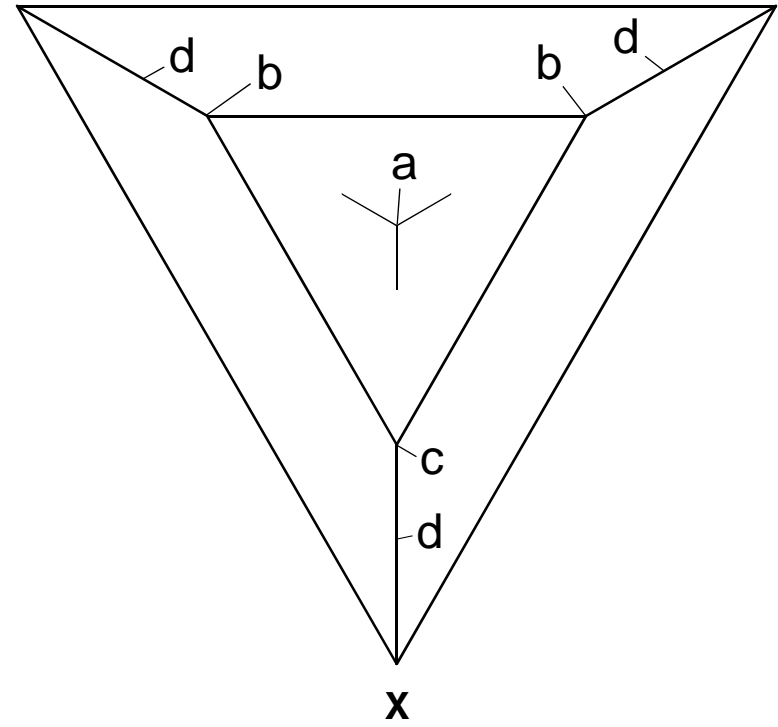
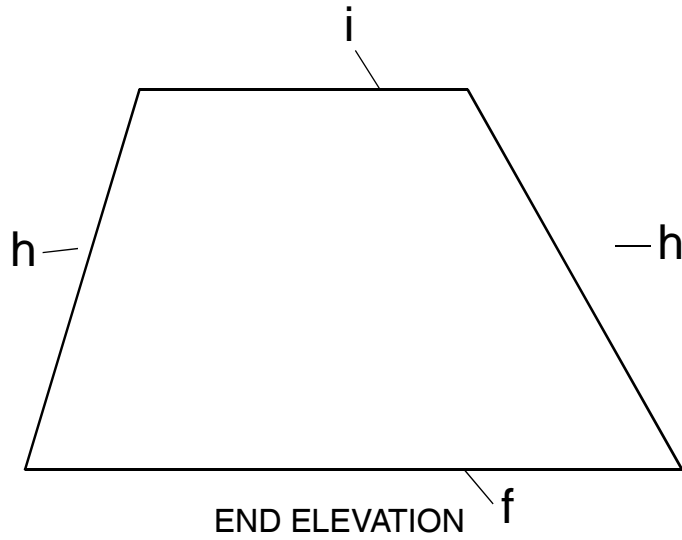
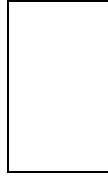

PLAN

Plan

- (a) Apex Position 2
- (b) Points established 1
- (c) Point 1
- (d) Sloping outlines 1
- (e) Triangles outlined 1

DA 6

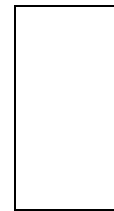

Question 8

- | | | |
|-----|----------------------------------|-----------|
| (a) | Wall detail 1 x b x h | 1 |
| (b) | Floor 1 x b | 1 |
| (c) | Wall thickness (all) | 1 |
| (d) | Chair position (from either end) | 1 |
| (e) | Chair 1 x b x h (2 from 3 for 1) | 2 |
| (f) | Back thickness | 1 |
| (g) | Bookcase position (either end) | 1 |
| (h) | Bookcase crate (2 from 3) | 1 |
| (i) | Shelves (2) | 1 |
| (j) | Shelf lines shown (2) | 1 |
| (k) | Plinth shown (3 lines) | 1 |
| (l) | Window position | 1 |
| (m) | Window size (length + height) | 1 |
| (n) | Window depth (3 lines) | 1 |
| (o) | Cushion lines at correct height | 1 |
| | Total DA | 16 |

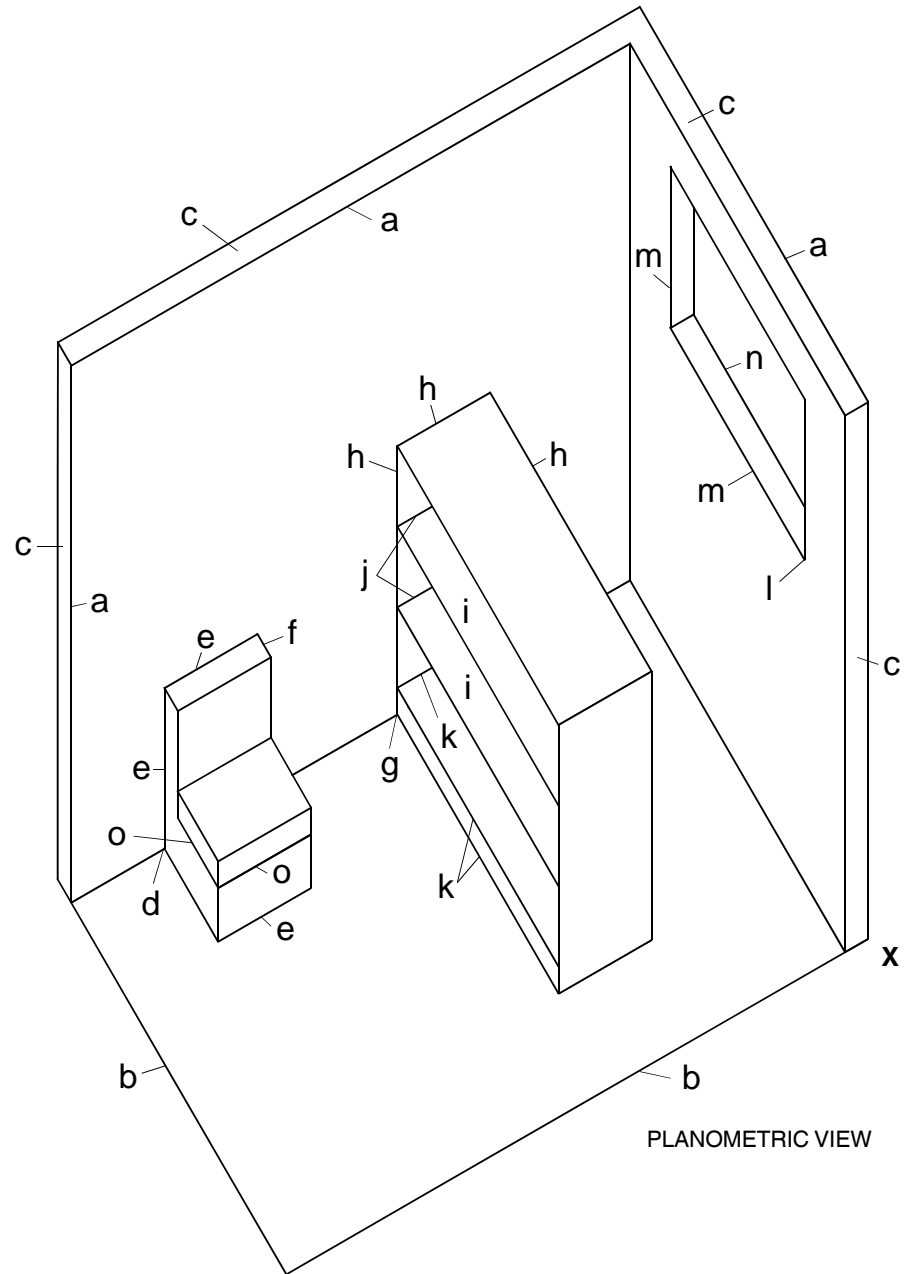

Question 9

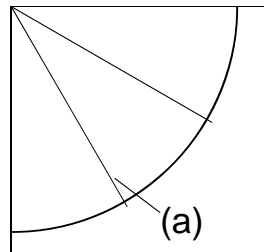

- (a) Div plan and project to Elev 1
- (b) Project Div to End Elev 1
- (c) Establish curve points 2
(8 points for 1; 12 for 2)
- (d) Good freehand curve 1
- (e) Vertical edges (both) 1
- (f) Horizontal line 1
- (g) Vertical lines; correct position 1
- (h) Horizontal lines; all 3 1
- (i) Horizontal line 1

Total DA 10

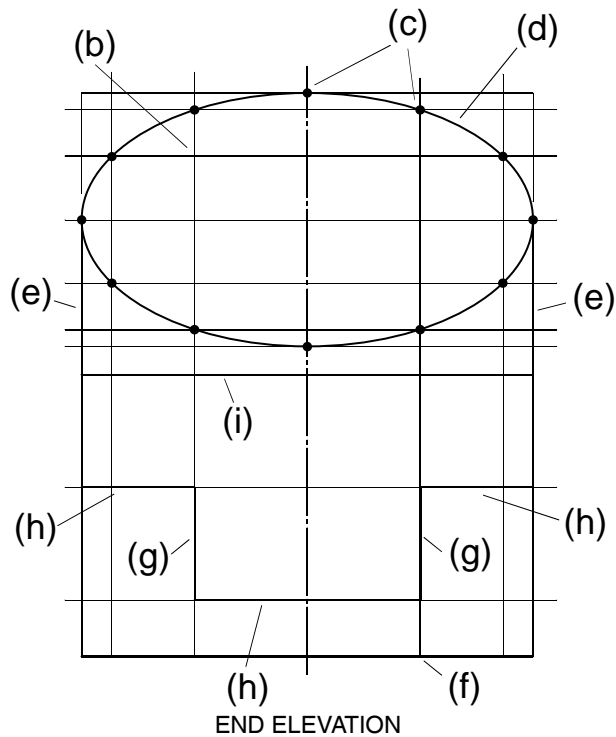

[END OF MARKING INSTRUCTIONS]