

--	--	--	--	--	--	--



CATHOLIC HIGH SCHOOL
PRIMARY SIX
PRELIMINARY EXAMINATION, 2006

SCIENCE
EM 1 / EM 2

Name: _____ ()

Class : Primary 6 _____

Date : 25 Aug 2006

BOOKLET A

30 Questions
60 Marks

Total Time for Booklets A & B : 1 hour 45 minutes

Instructions to Candidates

Do not open this booklet until you are told to do so.
Follow all instructions carefully.
Answer all questions.

PART 1 (60 marks)

For each question from 1 to 30, four options are given. One of them is the correct answer. Make your choice (1, 2, 3 or 4). Shade the correct oval (1, 2, 3 or 4) on the Optical Answer Sheet.

1. Samy observed an animal in a garden over a few weeks. He knew it was a mammal because it _____.

- A laid eggs
- B had four legs
- C had hair on its body
- D suckled its young

- (1) C only
- (2) A and C only
- (3) C and D only
- (4) B, C and D only

2.

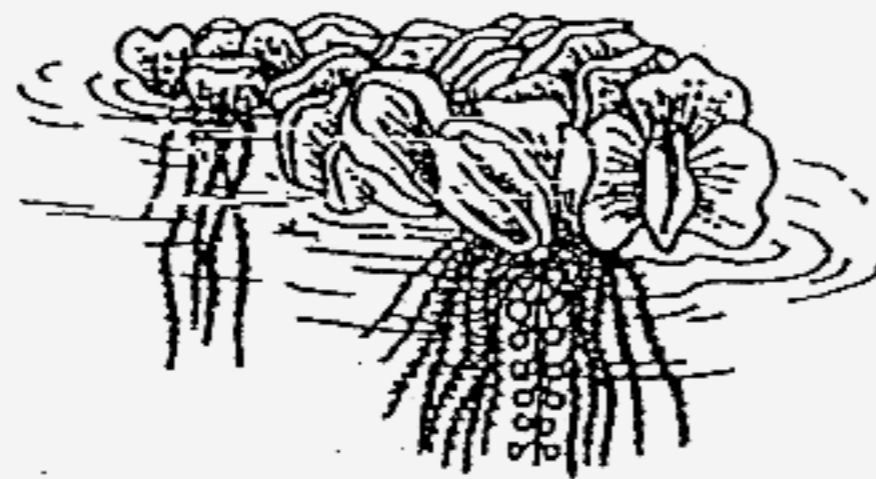

The diagram above shows the Water Moss Fern. Which of the following are structural adaptations that help it to float?

- A Spongy leaves
- B Waterproof coat of tiny hairs on leaf surface
- C Feathery branch similar to little roots

- (1) A only
- (2) B only
- (3) B and C only
- (4) A, B and C only

3. The diagram below shows a model of the human arm.

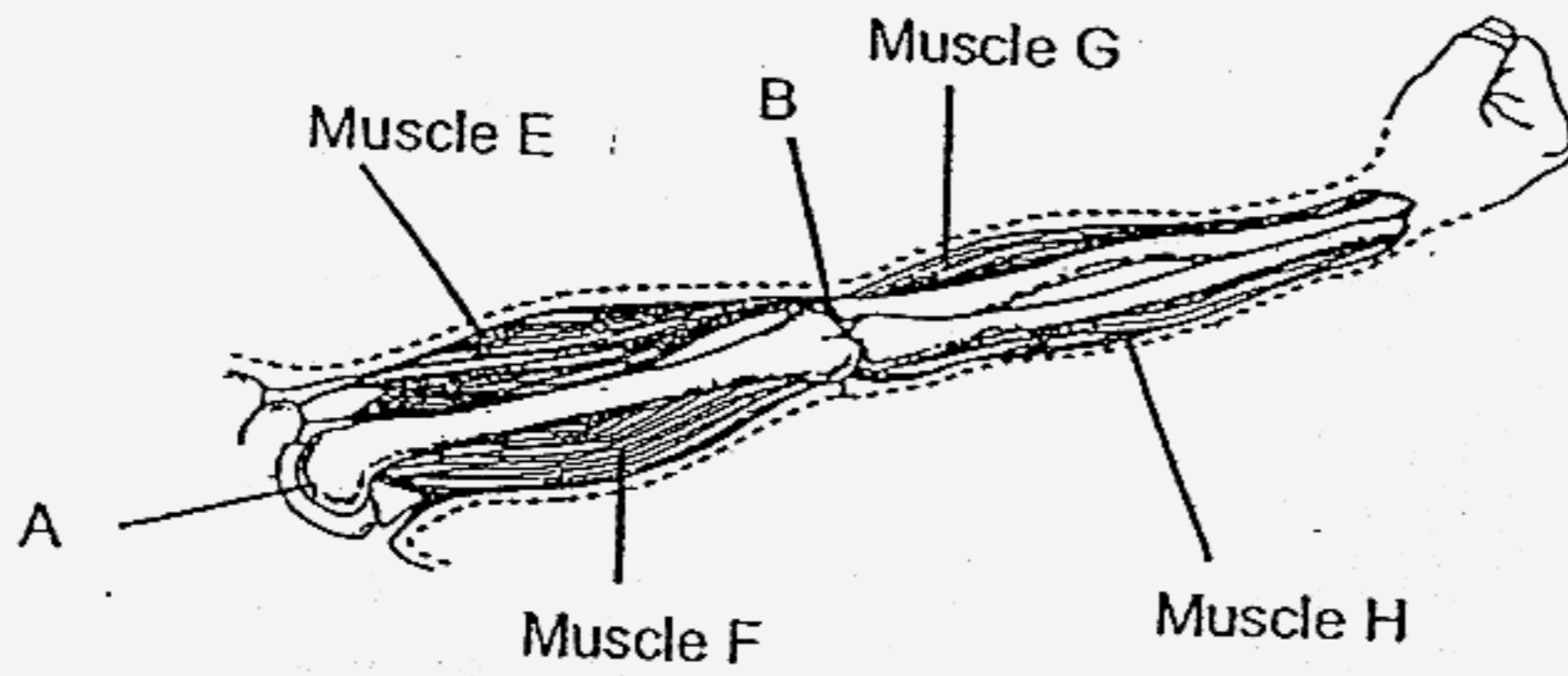

Ahmad wants to bend his arm at the elbow. Which one of the following describes correctly the parts that would enable him to do this action?

	Joint that enables movement	Muscle	
		Contract	Relax
(1)	B	E	F
(2)	B	F	E
(3)	A	G	H
(4)	A	F	G

4. The table below gives some information about 4 organisms A, B, C and D.

	A	B	C	D
Can make its own food	X	X	√	√
Can move freely from place to place	X	√	X	X
Has many cells	√	X	X	√

Which letter A, B, C or D best represents 'mould'?

- (1) A
- (2) B
- (3) C
- (4) D

5. The diagrams below show some human body systems.

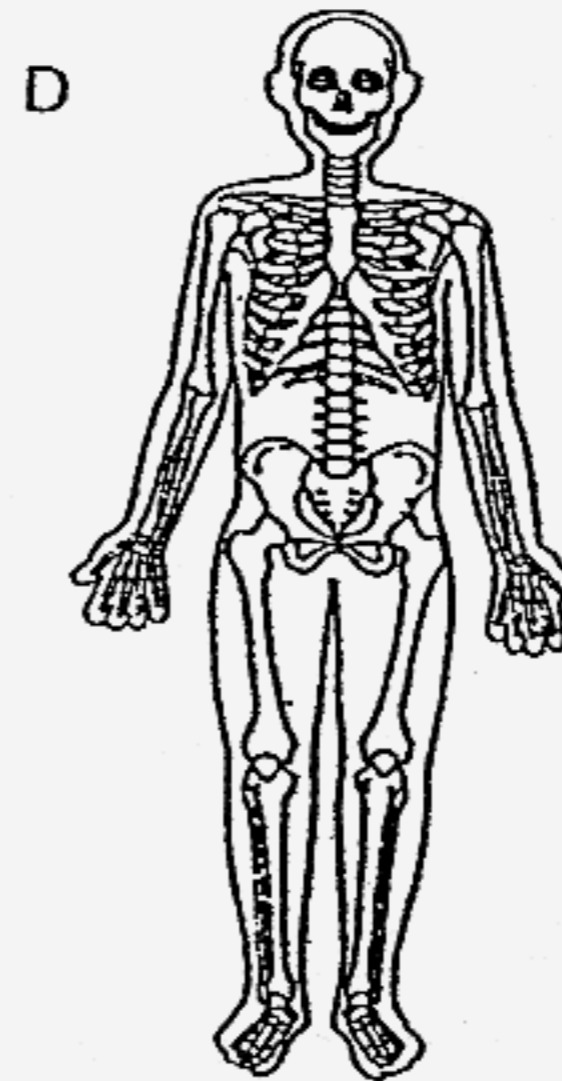
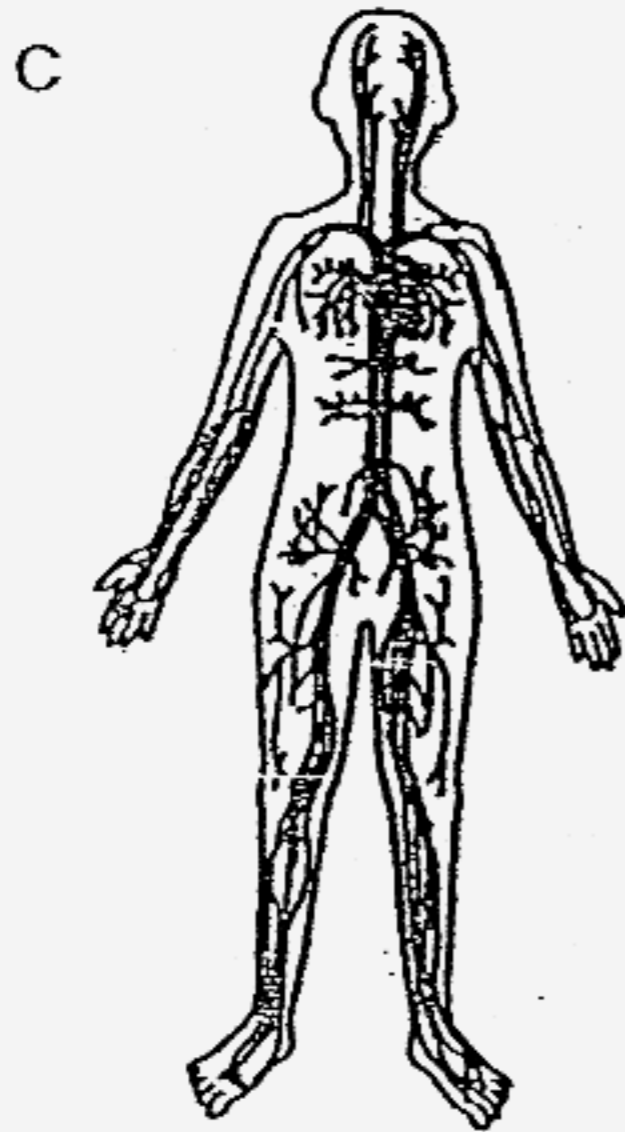
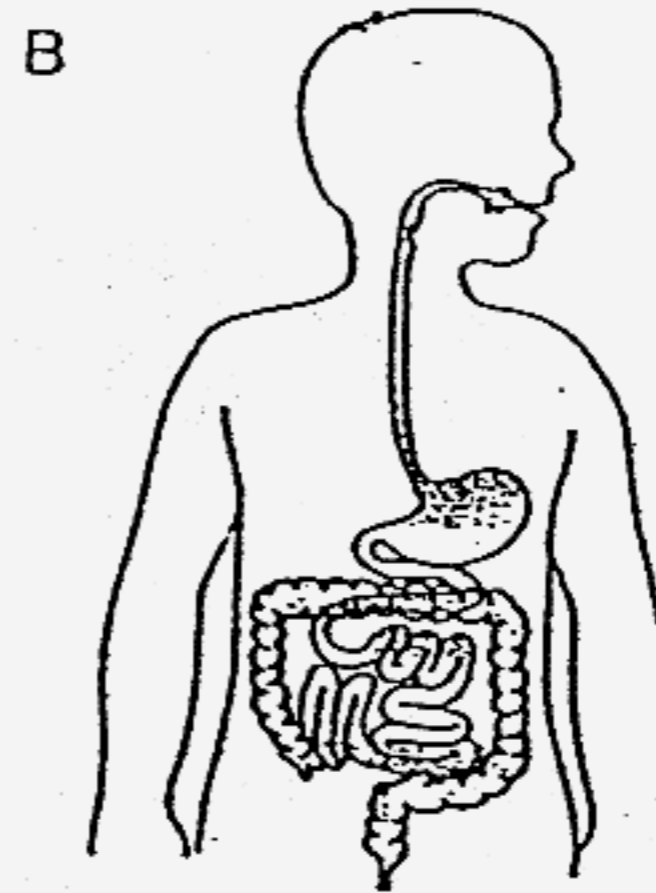
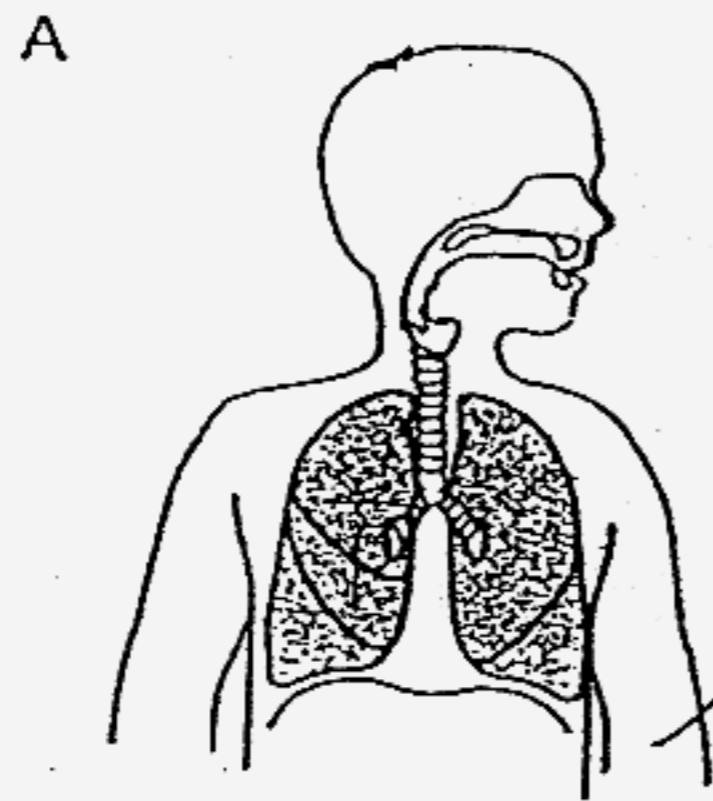

Our body cells get oxygen for respiration from System(s) _____.

- (1) A only
- (2) A and C only
- (3) B and C only
- (4) C and D only

6. Which one of the following graphs shows the correct relationship between the surface area of leaves on plants growing in the desert and its surrounding temperature?

(1)

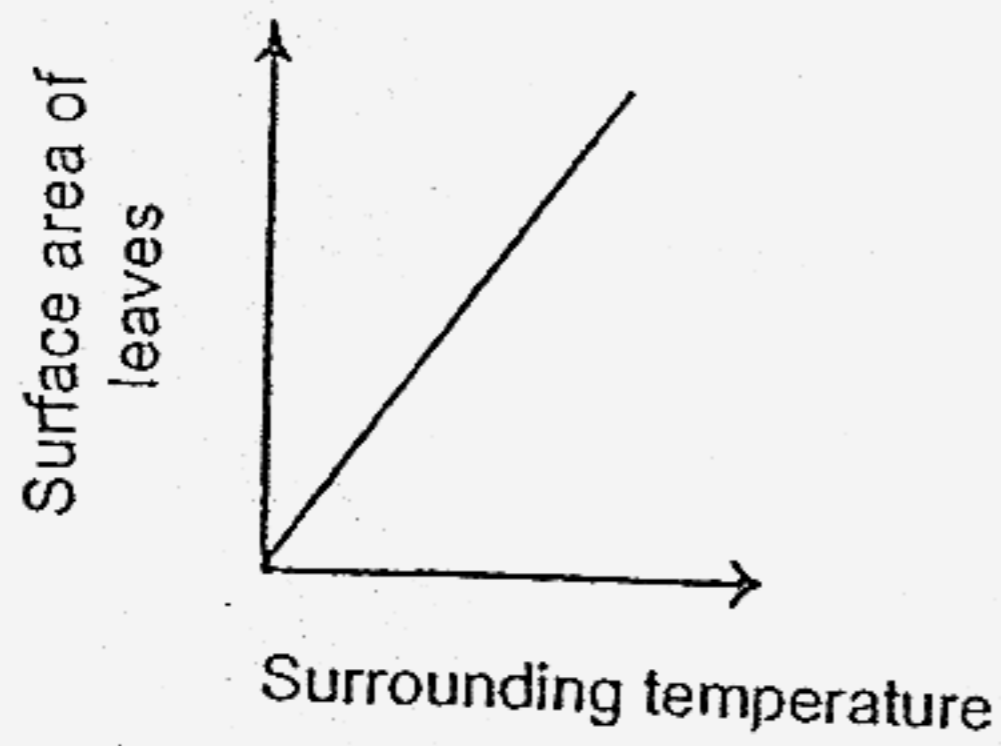

(2)

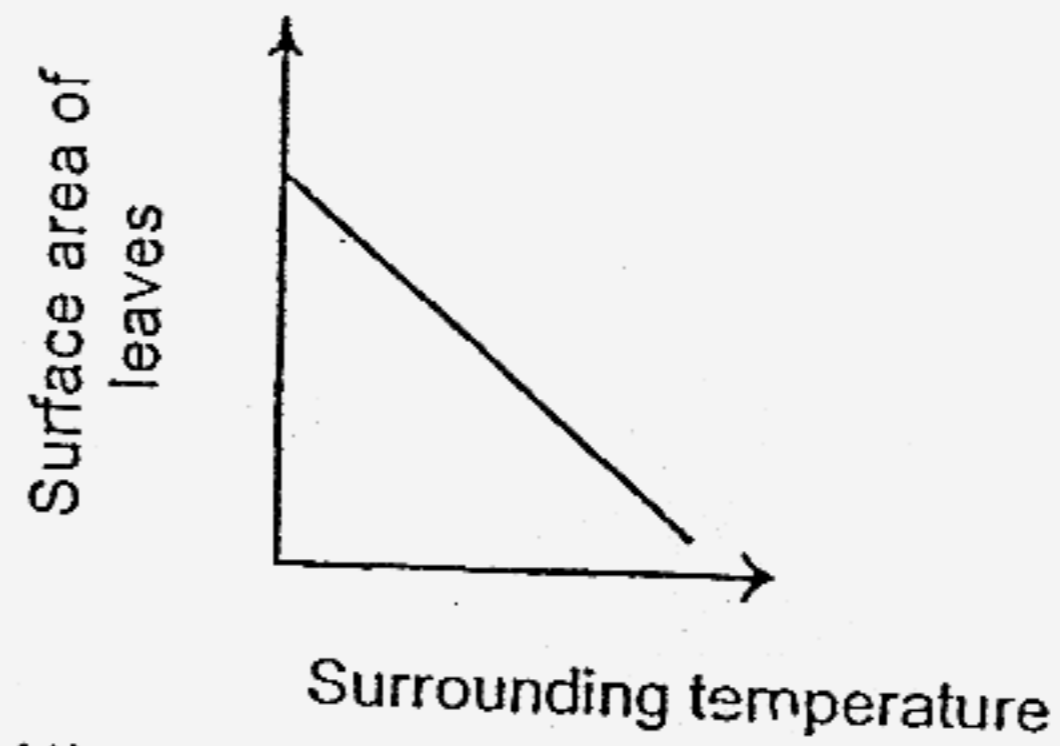

(3)

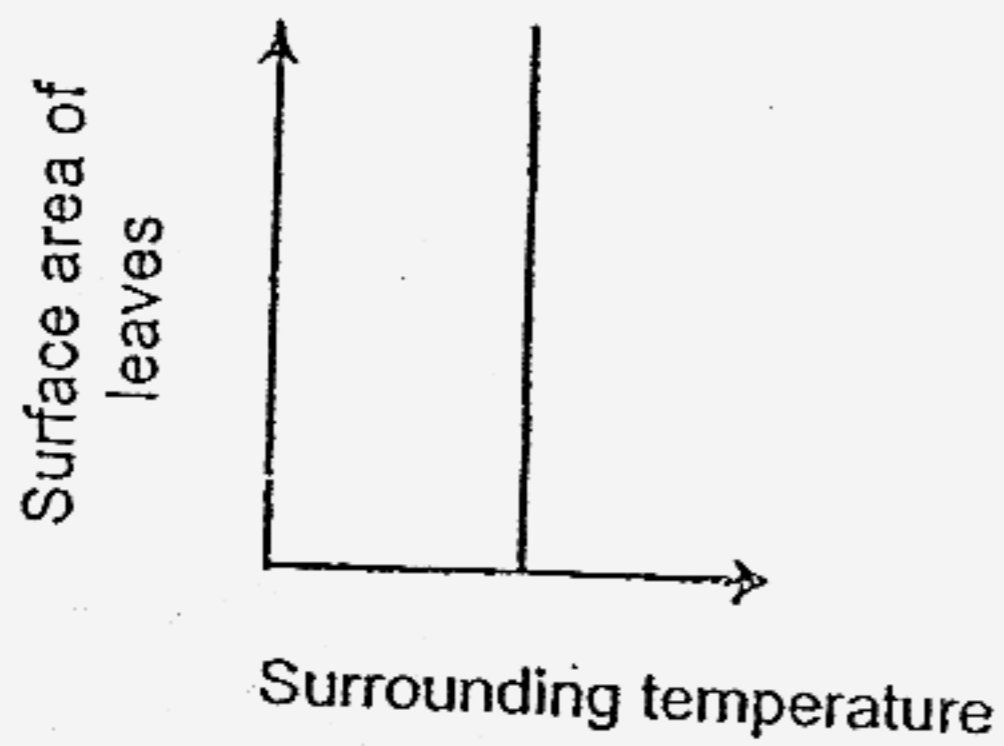

(4)

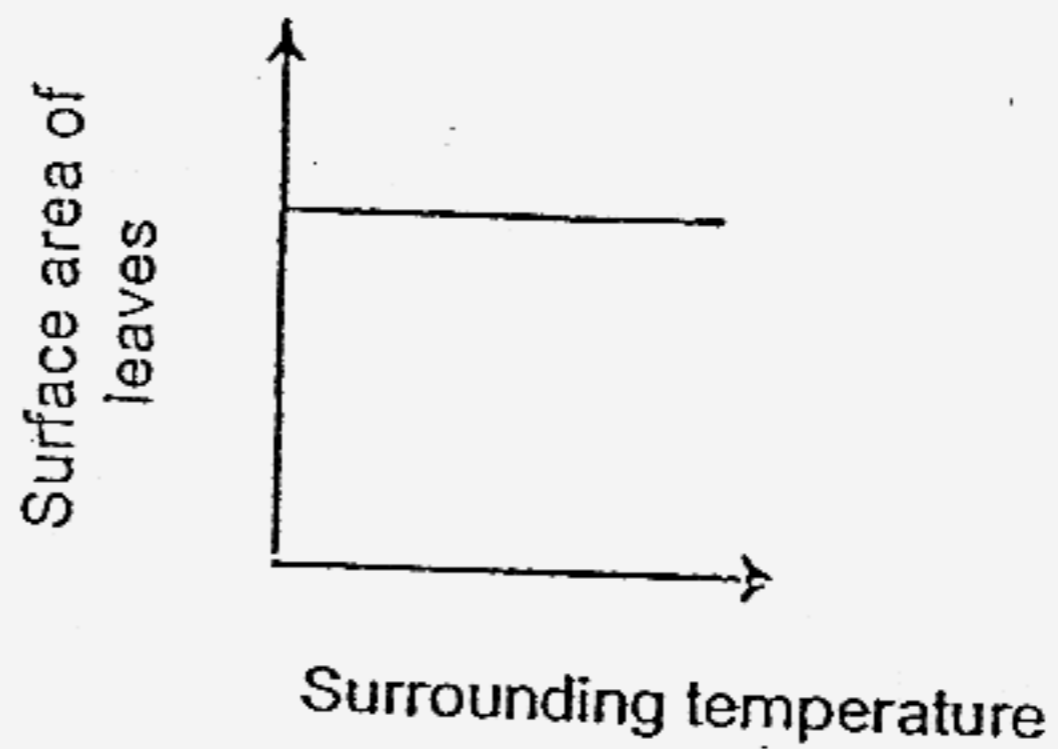

7. Alice placed 3 similar balsam plants in 3 similar beakers of water containing red dye. She trimmed off all the leaves from Plant A and some leaves from Plant B as shown in the diagram below.

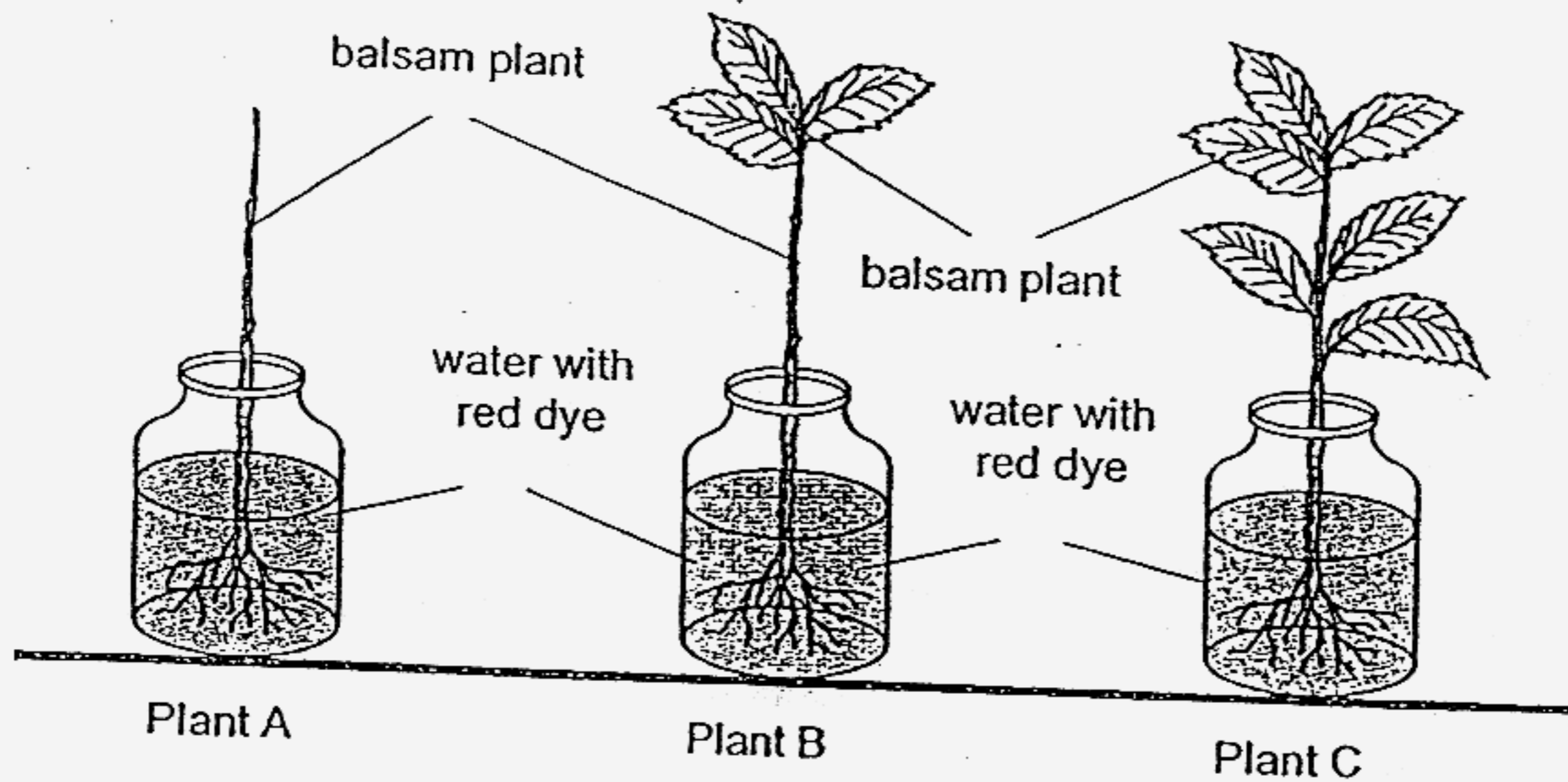

After a day, she cut the stems of the plants at 2 places, as shown below, and observed the red dye on the cut surface.

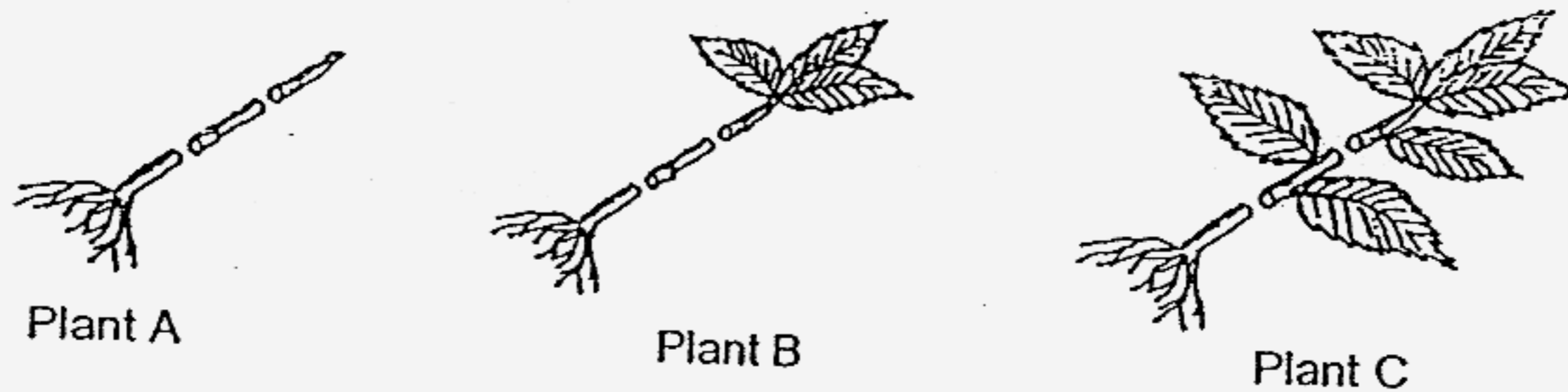

What was Alice trying to find out?
She was trying to find out if the _____

- (1) roots of the plant absorb water
- (2) leaves of the plant absorb water
- (3) stems help to transport water from the roots to the leaves
- (4) number of leaves affects the rate water travels up the stem

8. The flowchart below shows how yoghurt is made. Study it carefully.

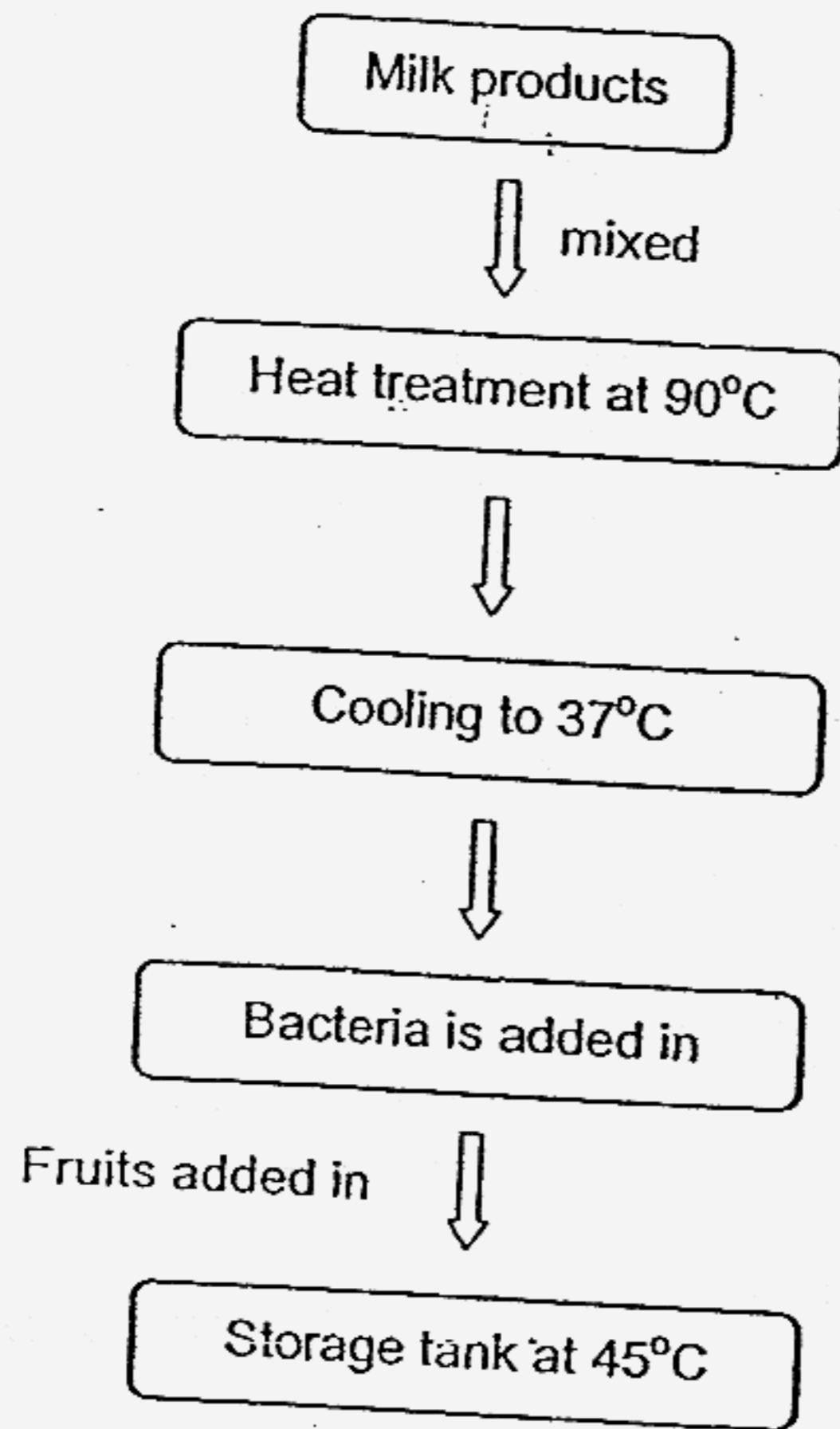

At which step of the yoghurt preparation is the bacteria killed?

- (1) Cooling at 37°C
- (2) Addition of fruits
- (3) Addition of bacteria
- (4) Heat treatment at 90°C

9. A well-watered rose plant is placed in a glass container as seen below. The amount of carbon dioxide and oxygen found in the container at the start of the experiment is shown below.

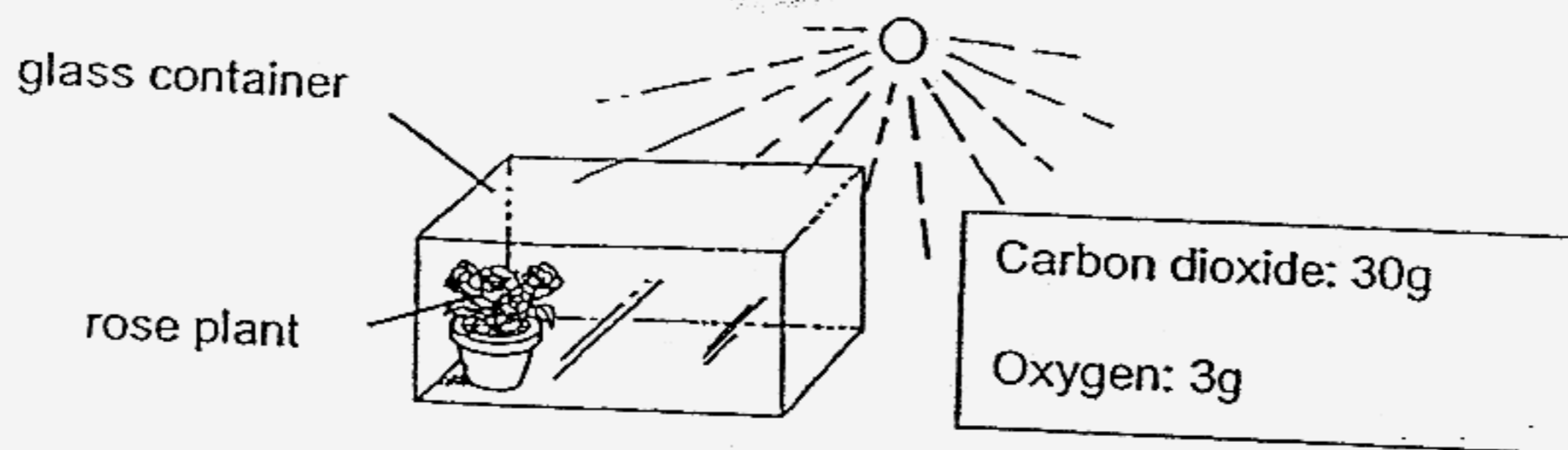

Which one of the following correctly shows the most likely amount of gases in the glass container after exposing it to sunlight for a few hours?

	Amount of carbon dioxide	Amount of oxygen
(1)	25g	6g
(2)	25g	3g
(3)	35g	6g
(4)	35g	1.5g

10. The graph below shows the number of days taken at various stages of the life cycles of insects A and B.

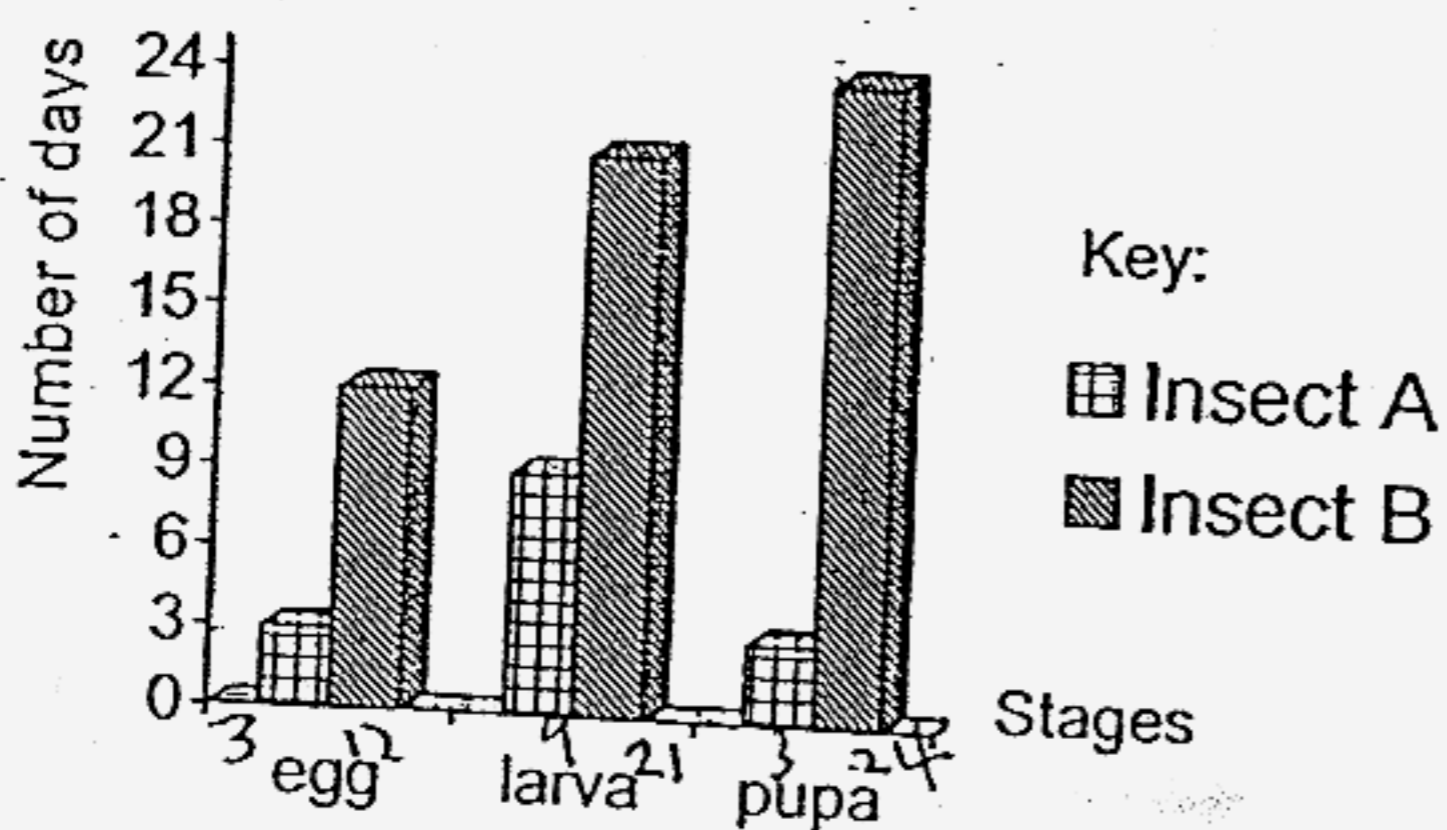

At which stage respectively, would Insects A and B be at on the 18th day after the eggs were laid?

	Insect A	Insect B
(1)	Pupa	Pupa
(2)	Pupa	Larva
(3)	Adult	Pupa
(4)	Adult	Larva

11. The graph below shows the length of a cell that was measured over a period of time.

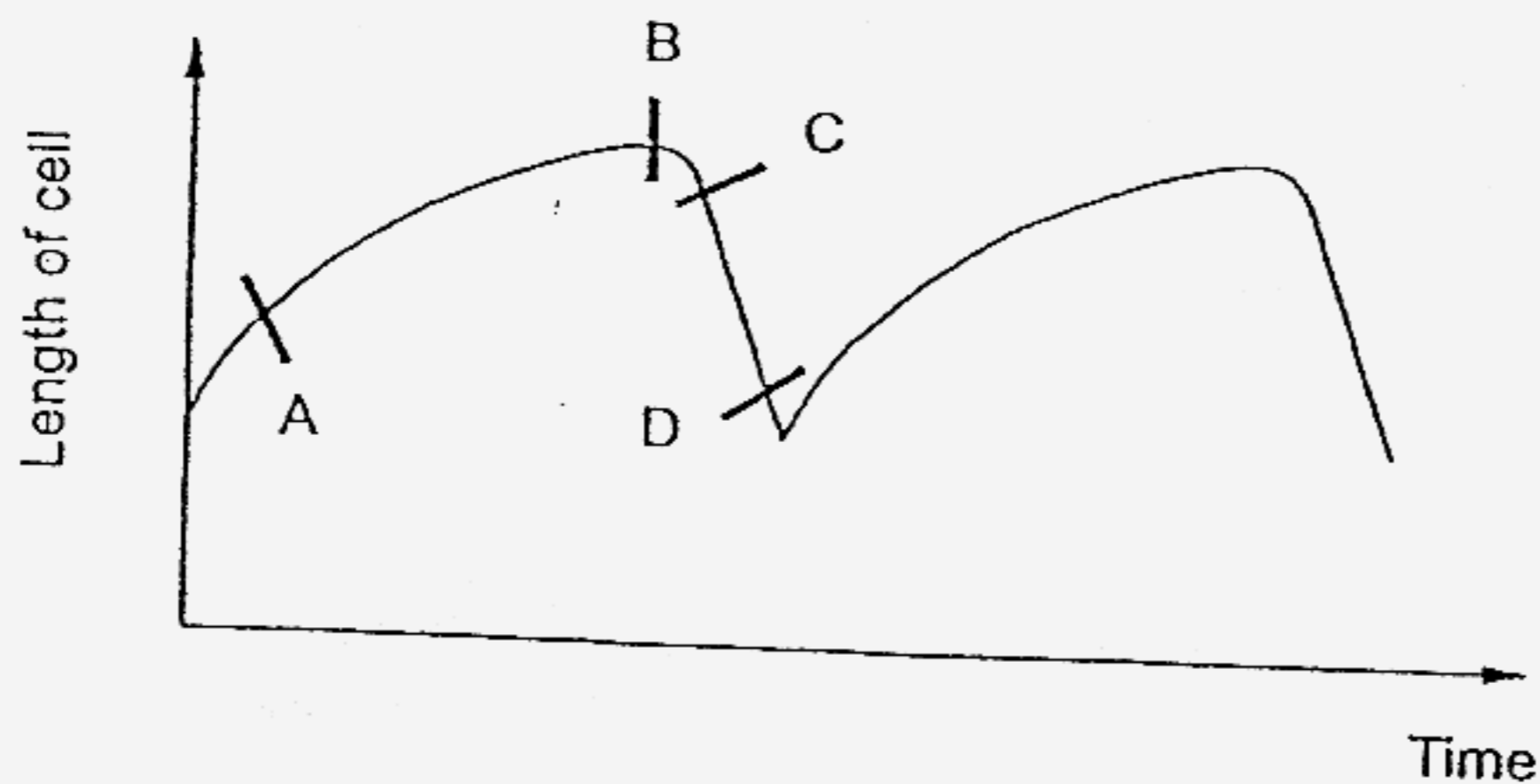

What is the process that probably took place at the part labelled CD?

- (1) Death
 - (2) Respiration
 - (3) Cell division
 - (4) Photosynthesis
12. Some pupils wanted to conduct an experiment to find out the effect of the types of soil on the growth of the plant. The table below gives details of the pots of plants set up by these pupils.

Variable	Pot A	Pot B	Pot C	Pot D
Type of plant	Green bean	Green bean	Maize	Green bean
Type of soil	Sandy	Garden	Garden	Sandy
Amount of soil	1 kg	1 kg	1 kg	1 kg
Amount of water /day	60 ml	40 ml	60 ml	40 ml
Amount of fertilizer/day	5g	10g	5g	10g

Which of the pots of plants should they use to conduct a fair test?

- (1) Pots A and C only
- (2) Pots B and D only
- (3) Pots B and C only
- (4) Pots A and D only

13. The classification table below shows how some plants reproduce.

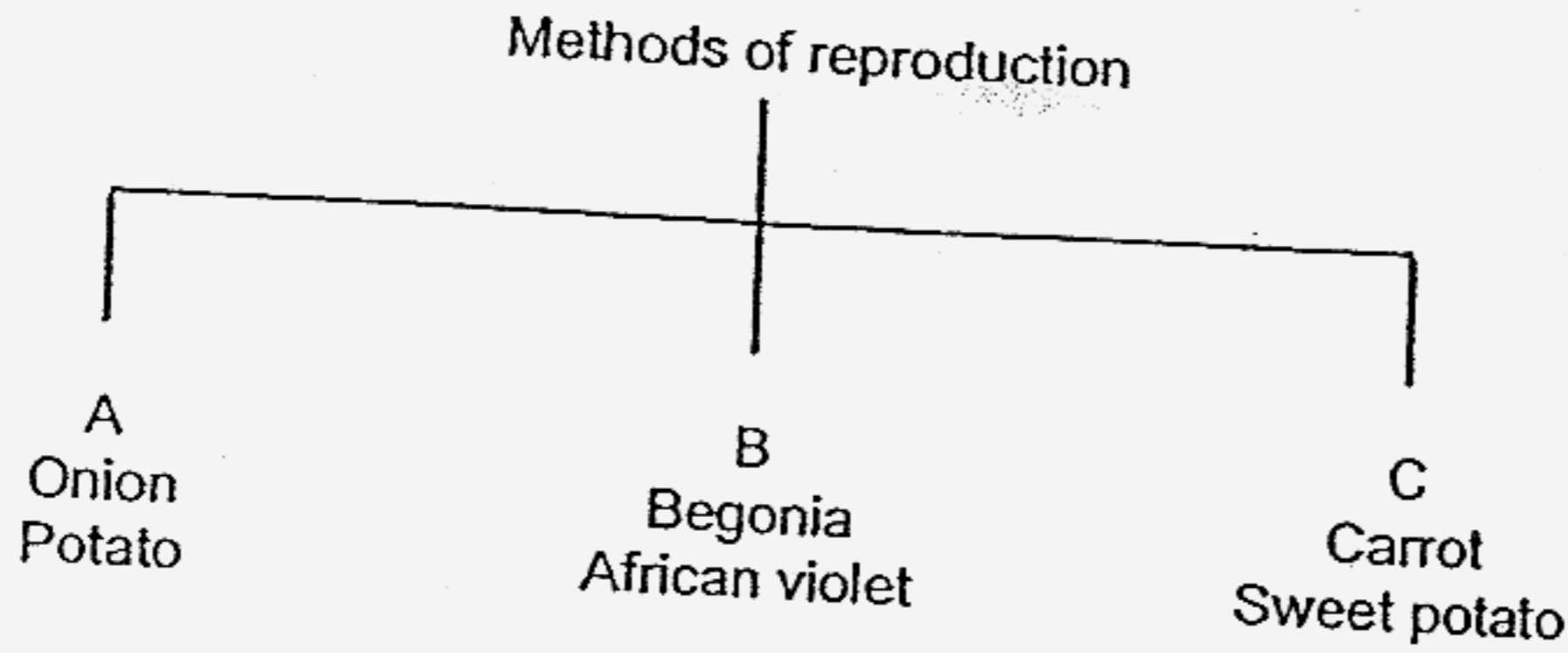

Which one of the following shows correctly the plant part that the plants are grown from?

	A	B	C
(1)	Root	Seed	Leaf
(2)	Seed	Suckers	Root
(3)	Root	Leaf	Underground stem
(4)	Underground stem	Leaf	Root

14. In a certain country, farmers spray their grain crops with insecticides to kill insects. The diagram below shows the level of insecticide found in the birds that are found in the food chains.

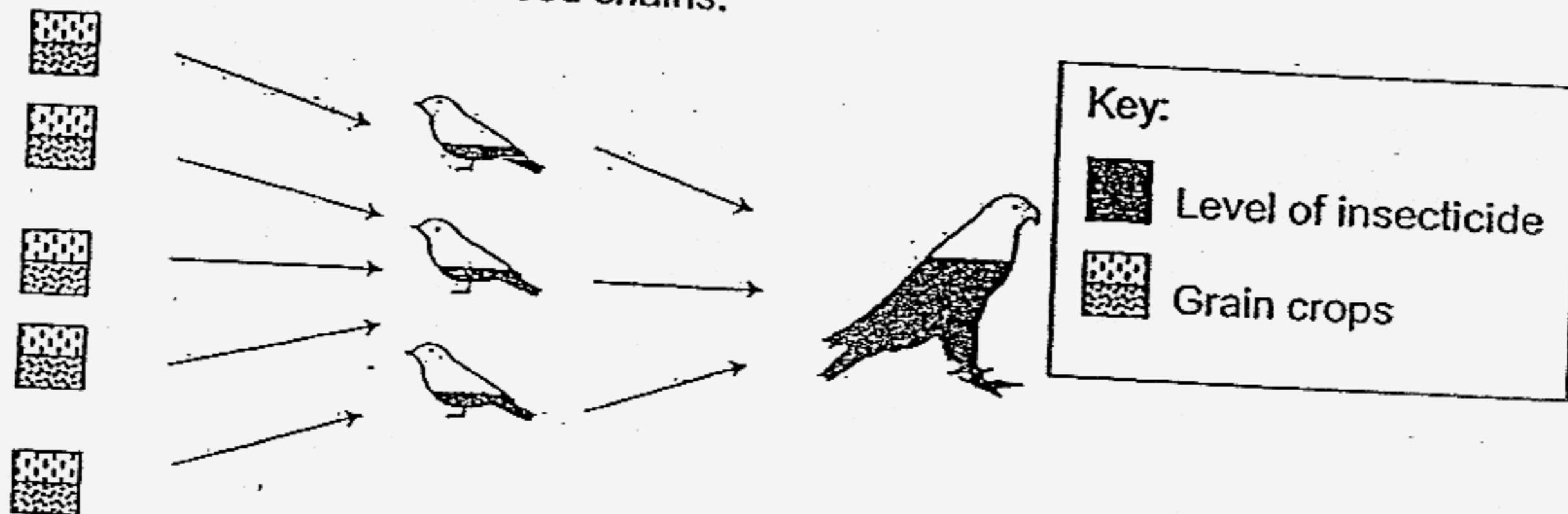

What conclusion can you infer from the information given above?
As the insecticide passes along the animals in the food chain, its level

- (1) decreases because there are fewer carnivores than herbivores
- (2) increases because each animal eats a bigger portion of the food chain
- (3) decreases because the animals are bigger further along the food chain
- (4) increases because each animal eats food that has a higher level of insecticide

15. Ahmad has a rare blood disease. His mother and sister do not have this disease. However, his father and brother are carriers of this disease. Which one of the family trees shown below correctly represents the above information?

(1)

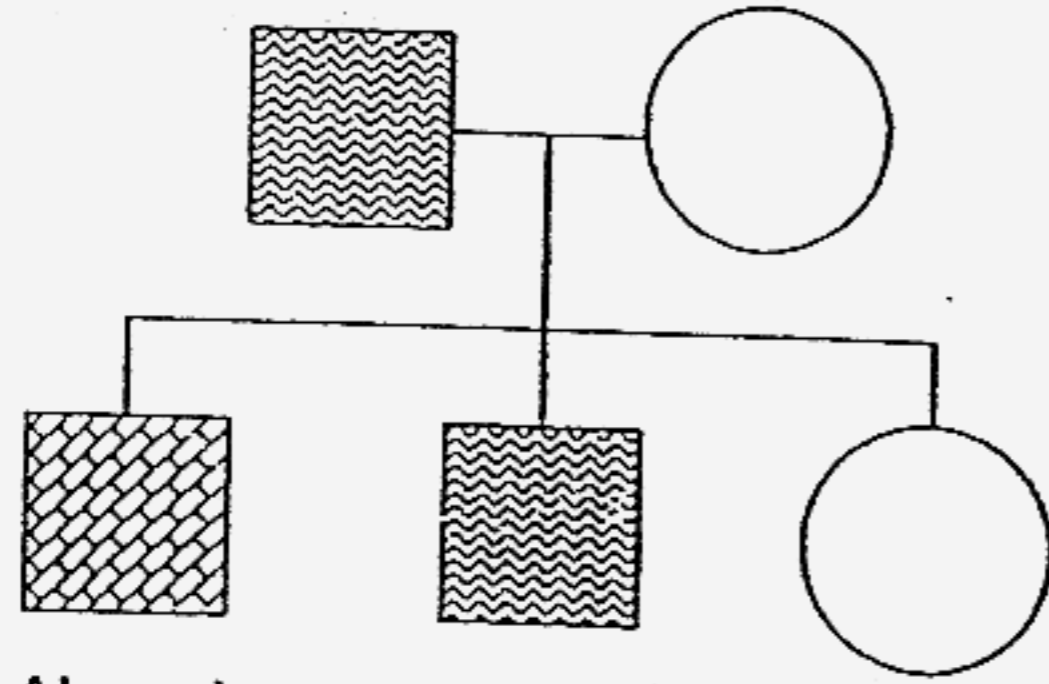

Ahmad

(2)

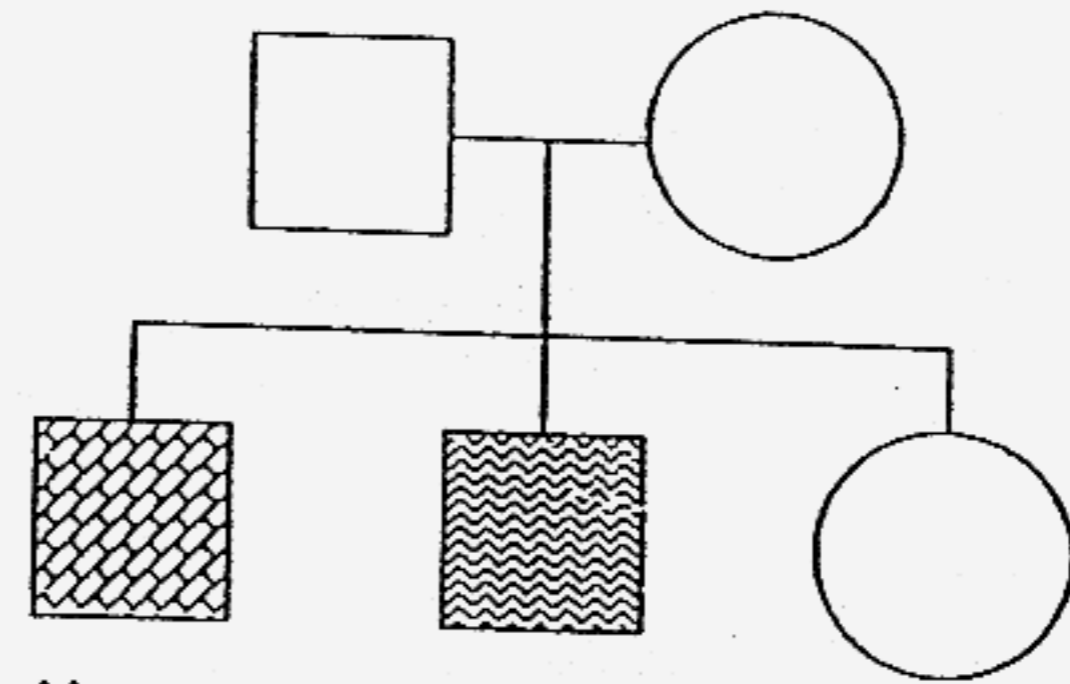

Ahmad

(3)

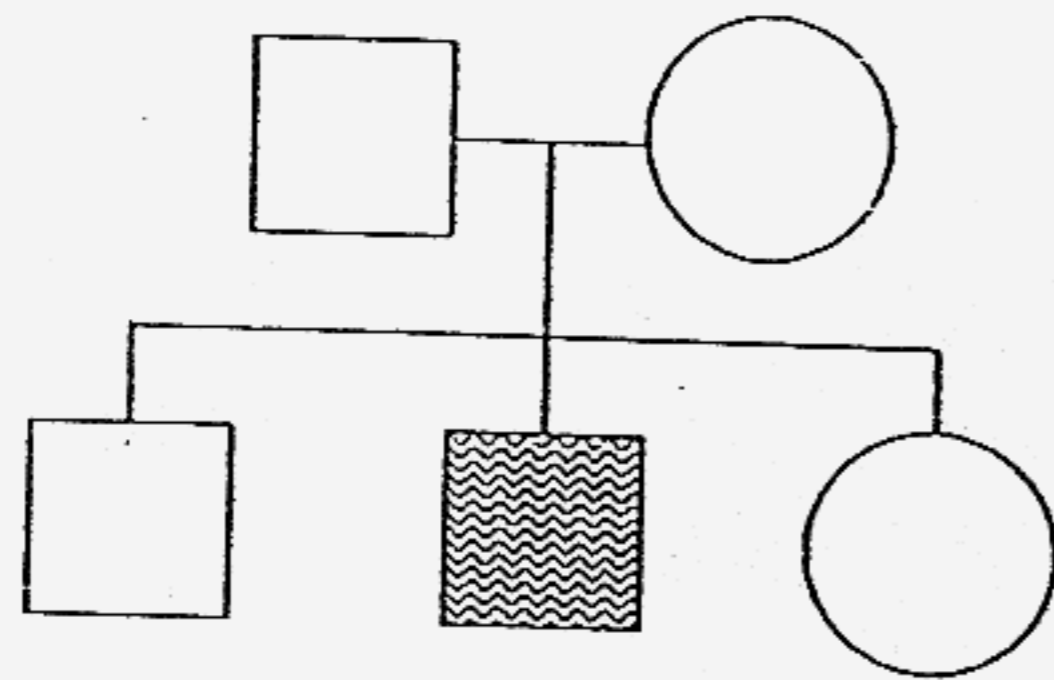

Ahmad

(4)

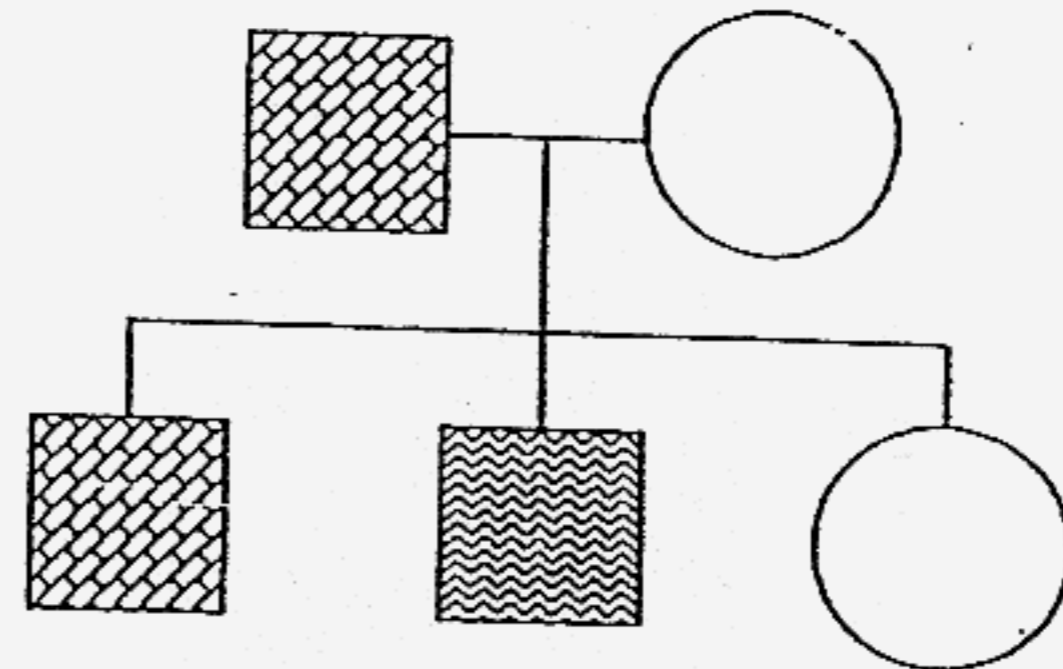

Ahmad

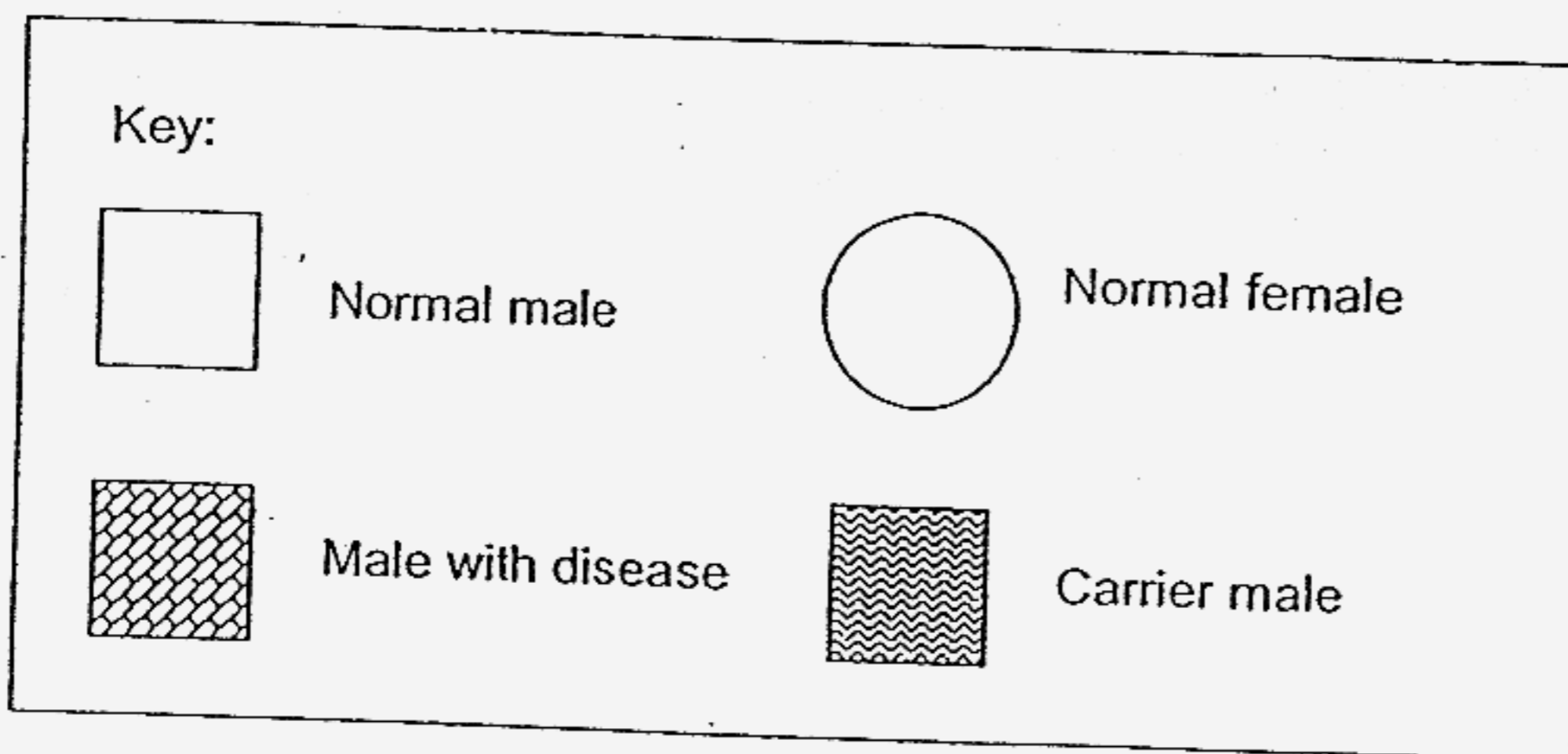

16. Ben filled up a 150 cm^3 measuring cylinder with water. He filled up another 150 cm^3 measuring cylinder with pebbles. Next, he transferred both the water and the pebbles into a 350 cm^3 measuring cylinder.

The volume occupied by the water and pebbles in the cylinder is likely to be _____.

- (1) 150 cm^3
- (2) 300 cm^3
- (3) more than 300 cm^3
- (4) between 150 cm^3 and 300 cm^3

17. Alloys are a mixture of 2 metals. The strength of an alloy is measured by the force required to mould them. The graph below shows the strength and weight of four metal alloys A, B, C and D.

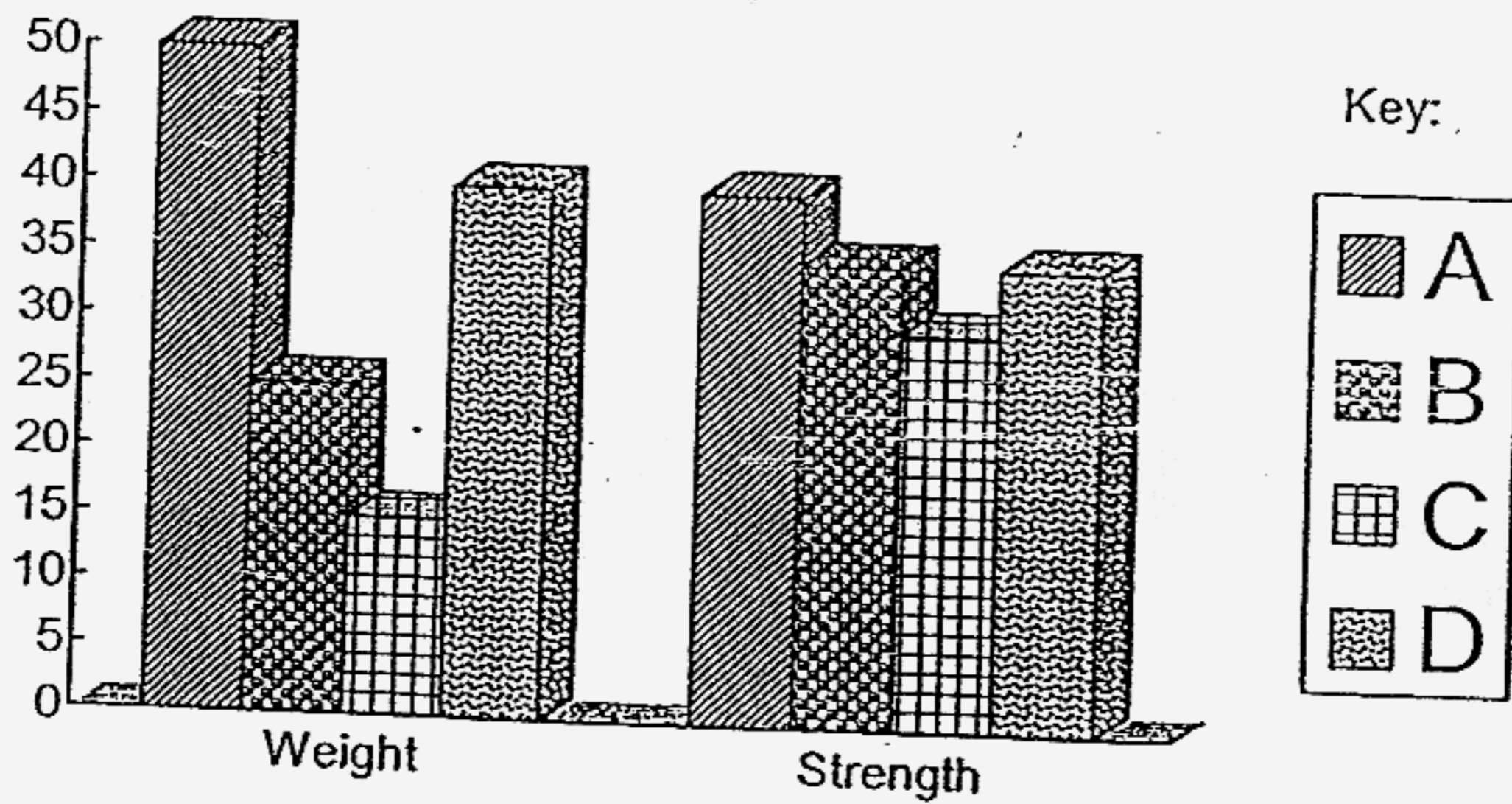

If a sculptor wants to sculpt a metal structure from an alloy that is lightweight and easily moulded, which metal alloy should he use?

- (1) A
- (2) B
- (3) C
- (4) D

18. Marcus set up an experiment to test the properties of a magnet.

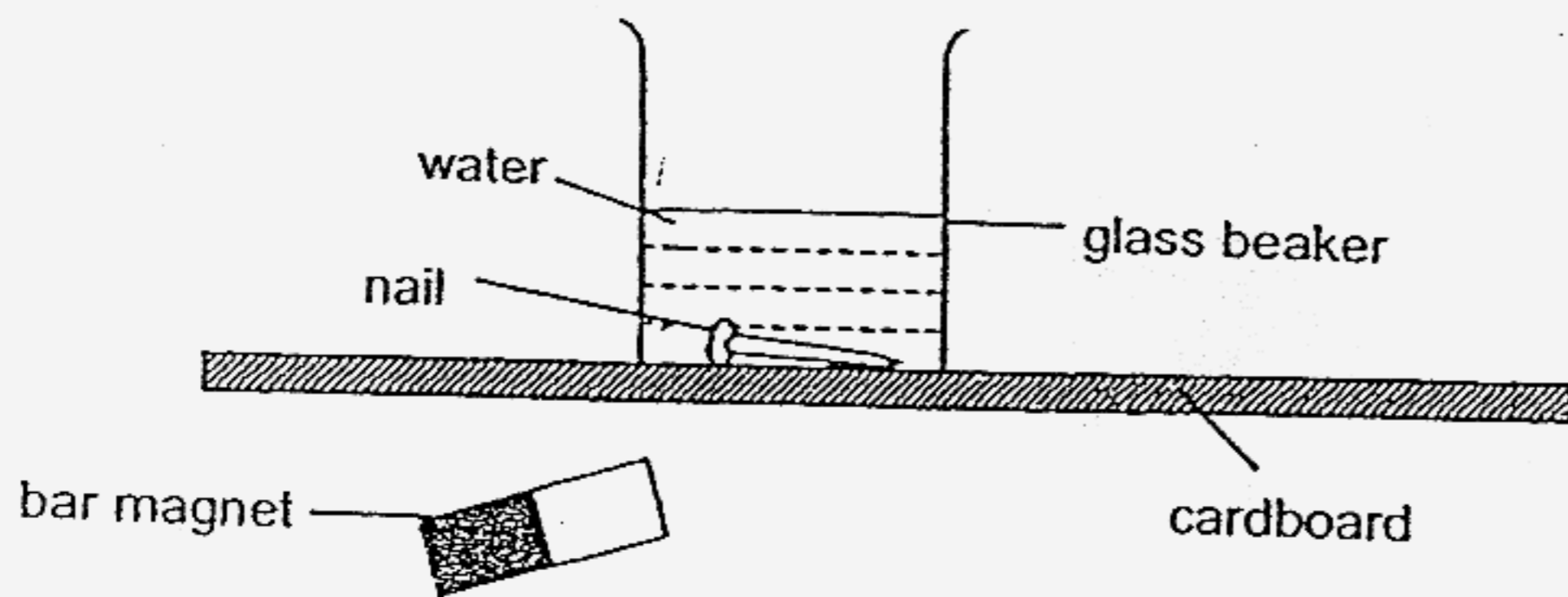

What will happen to the nail when the bar magnet is moved under the iron nail below the base of the glass?

- (1) It will not move at all.
 - (2) It will be attracted to the magnet.
 - (3) It will float to the surface of the water.
 - (4) It will be repelled and move to one side of the glass.
19. Susan wanted to find out whether light can pass through some materials. She carried out the experiment shown below in a dark room.

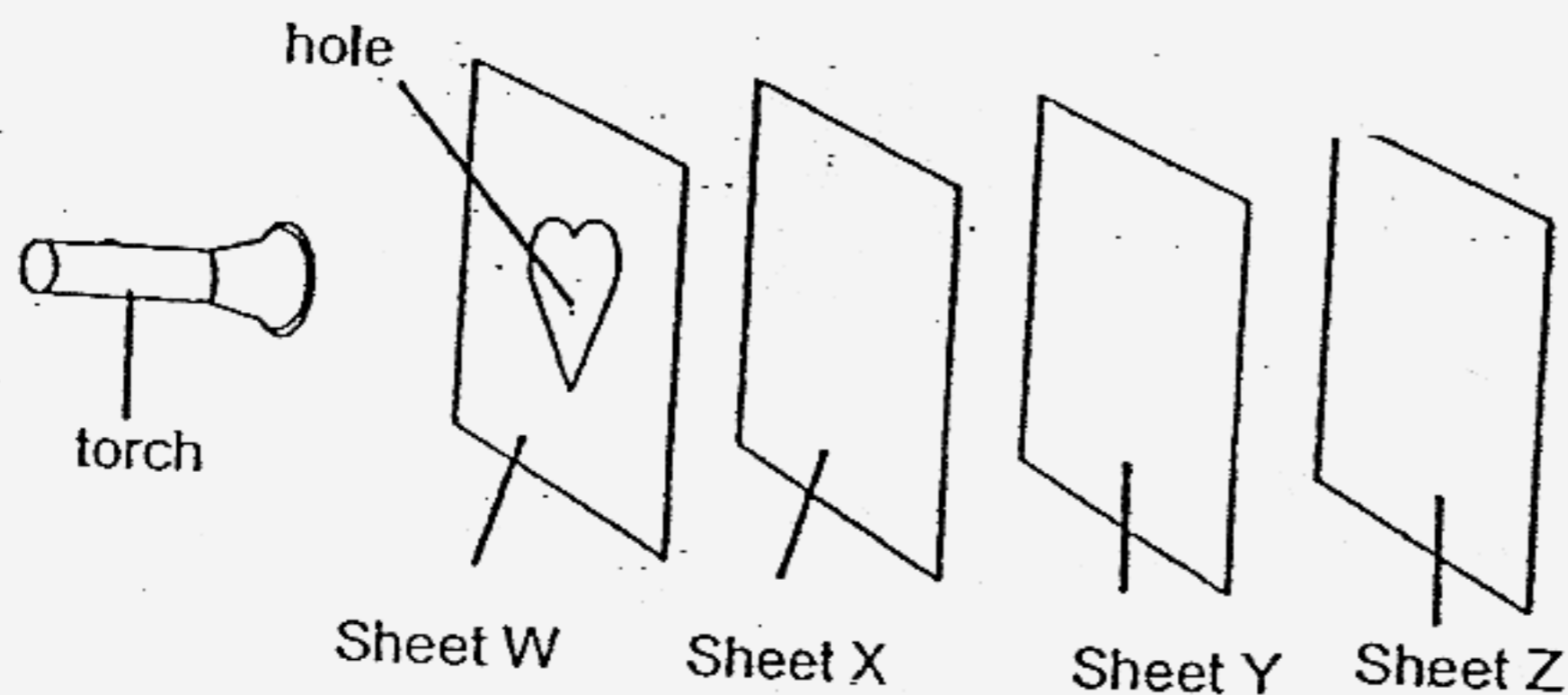

Sheets W, X, Y and Z are arranged in a straight line. When the torch is switched on, a bright heart-shaped patch of light is seen on Sheet X only.

Which one of the following correctly describes the properties of the materials that sheets W, X, Y and Z are made of?

	Allows light to pass through	Does not allow light to pass through	Not possible to tell
(1)	W and X	Y	Z
(2)	Y and Z	X	W
(3)	None	W and X	Y and Z
(4)	W and X	None	Y and Z

20. A glass cover was used to cover a mug which contained some very hot water.

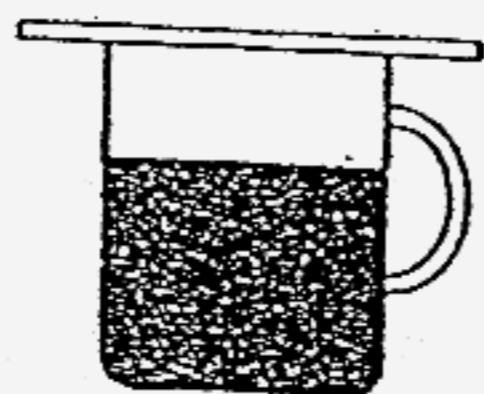

Beginning of experiment

After half an hour, Sam observed some changes. Which one of the following diagrams shows the correct changes observed by Sam?

(1)

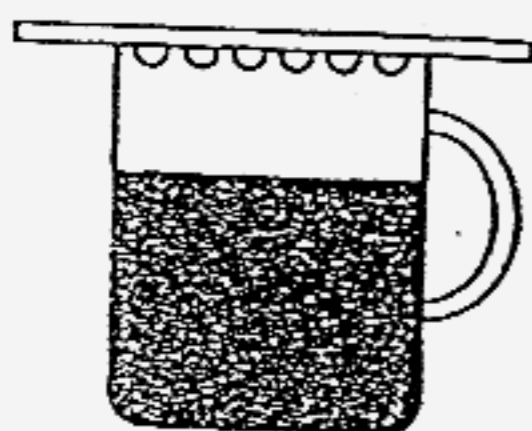

(2)

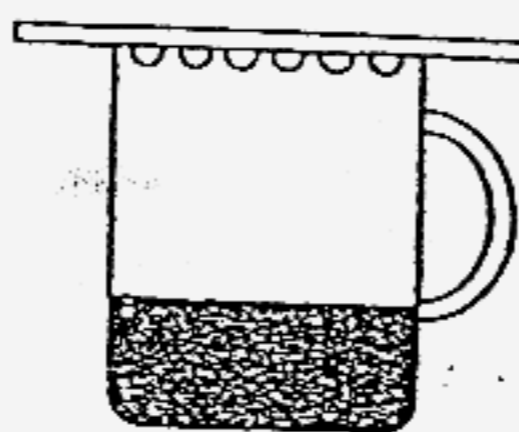

(3)

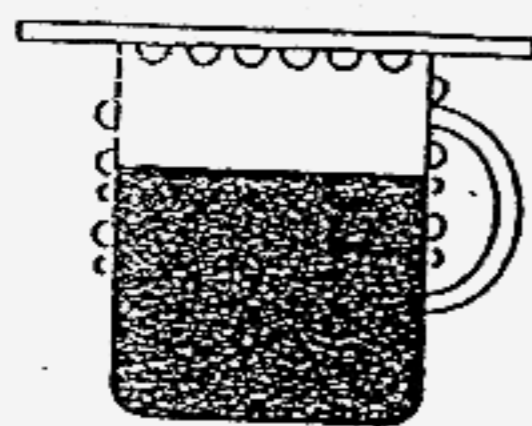

(4)

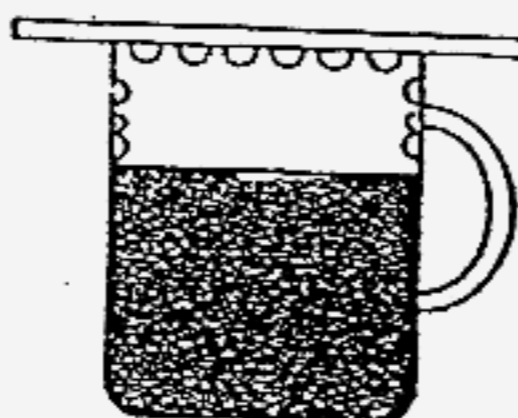

21. Kumar and Rahim were playing on a see-saw in the playground. They sat at the same distance from the centre of the see-saw.



Which one of the following ways can be taken by Kumar and Rahim in order to balance the see-saw?

- A Kumar should move as far back as he can.
- B Kumar should move towards the centre of the see-saw.
- C Rahim should move backwards.
- D Rahim should move towards the centre of the see-saw.

- (1) A and C only
- (2) A and D only
- (3) B and C only
- (4) B and D only

2. John observes the drop of red ink in the flask at regular intervals when it is placed in a basin of hot water as shown in the experiment below. He observes that the drop of red ink in the tube falls first and then rises.

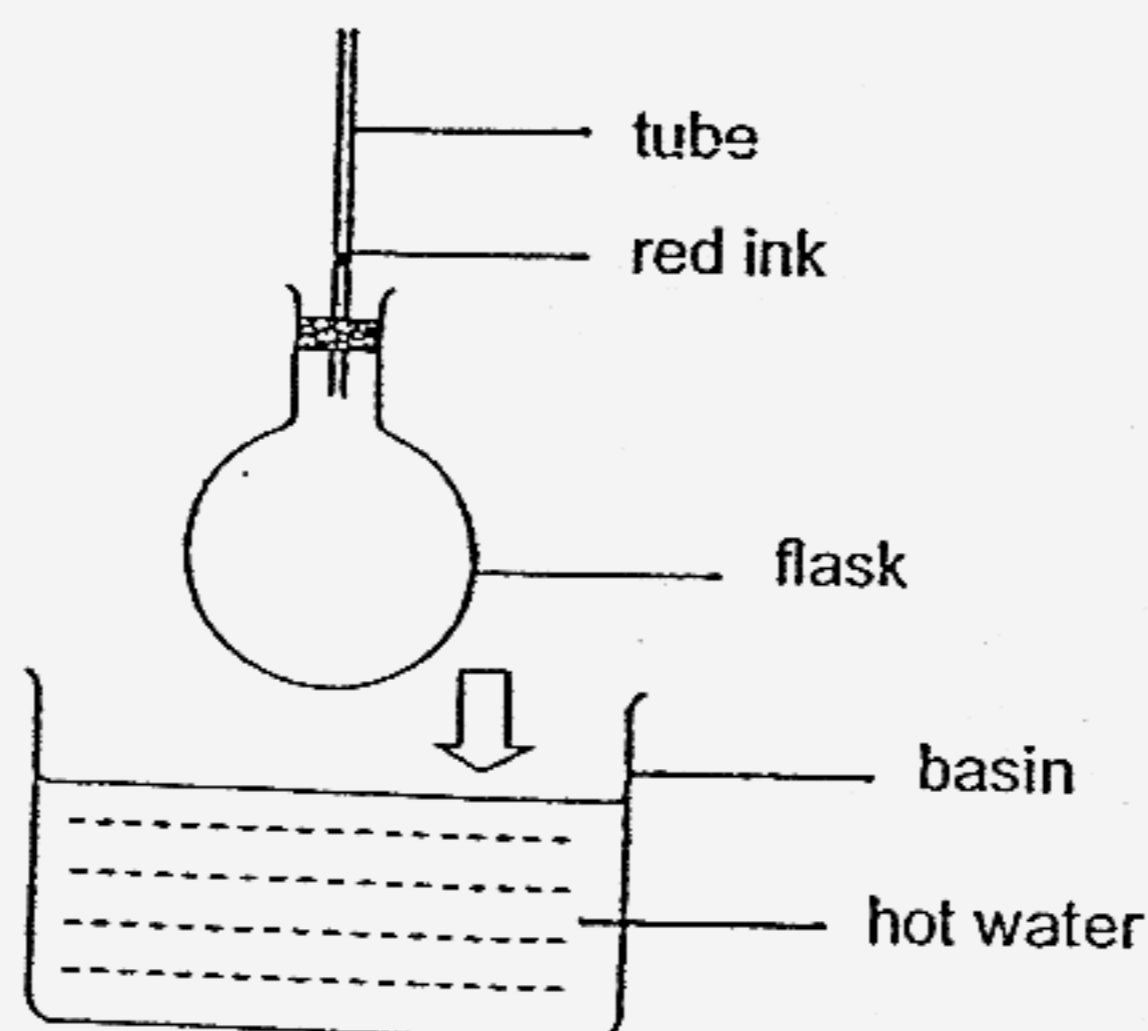

John made the following conclusions based on his observations.

- A The flask expands more than the air.
- B The flask expands first followed by the air.
- C The air is compressed first and then expands.
- D Gravity causes the red ink to fall first as the flask is lowered into the basin.

Which of John's conclusion(s) is/are correct?

- (1) A only
- (2) B only
- (3) A and C only
- (4) B and D only

23. Benny placed a big block of ice in a small enclosed room. He noticed that the block of ice started melting after some time as shown in the diagram below.

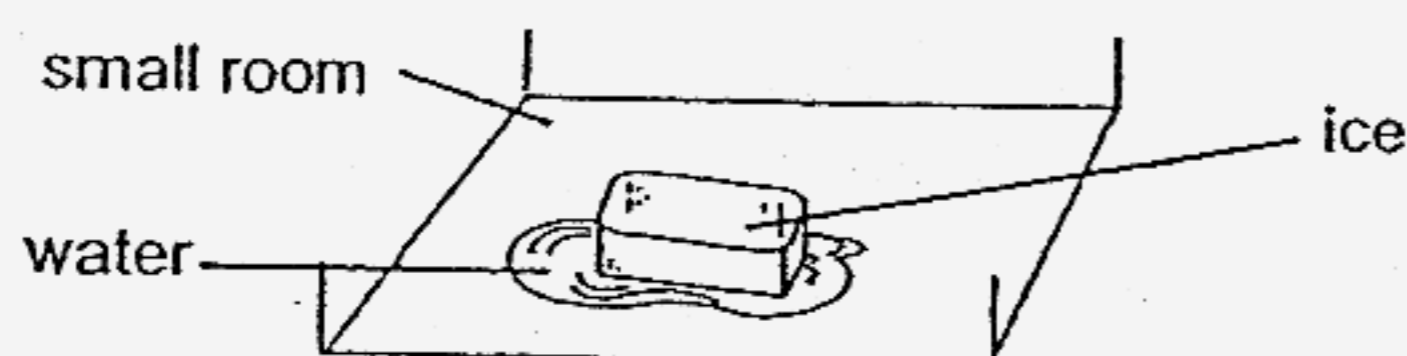

Which one of the following describes what happened to the temperature of the ice, water and small room when the ice was melting?

	Temperature of		
	Ice	Water	Small room
(1)	No change	Decrease	Increase
(2)	No change	Increase	Decrease
(3)	Decrease	Increase	Decrease
(4)	Increase	Decrease	Increase

24. The diagram shows a boy holding a fishball using a pair of chopsticks.



Which force allows him to do this?

- (1) Gravity
 (2) Pulling force
 (3) Magnetic force
 (4) Frictional force
25. Which of the events listed below occur as a result of the Earth's spinning about its own axis?
- A The change of season from spring to winter.
 B The shadow of a building varying at different times of the day.
 C The movement of the Sun across the sky from sunrise to sunset.
- (1) A and B only
 (2) A and C only
 (3) B and C only
 (4) A, B and C
26. PSI (Pollutant Standards Index) values give an indication of the air quality. The indication of the air quality with the associated range of PSI values are shown in the table below.

PSI Value	Air Quality
1-50	Good
51-100	Moderate
101-200	Unhealthy
210-300	Very unhealthy
Above 300	Hazardous

The table below shows the PSI in Singapore over a few days.

Day 1	Day 2	Day 3	Day 4	Day 5
45	80	120	135	140

Which one of the following reasons can most likely explain the sudden increase in PSI in the town from Day 1 to Day 5?

- (1) Cutting down of trees in the town.
 (2) An increase of vehicles on the road.
 (3) A forest fire in a neighbouring country.
 (4) An increase in the number of cigarette smokers.

27. The diagram below shows the movement of a basketball as it falls through the basket, hits the ground and bounces.

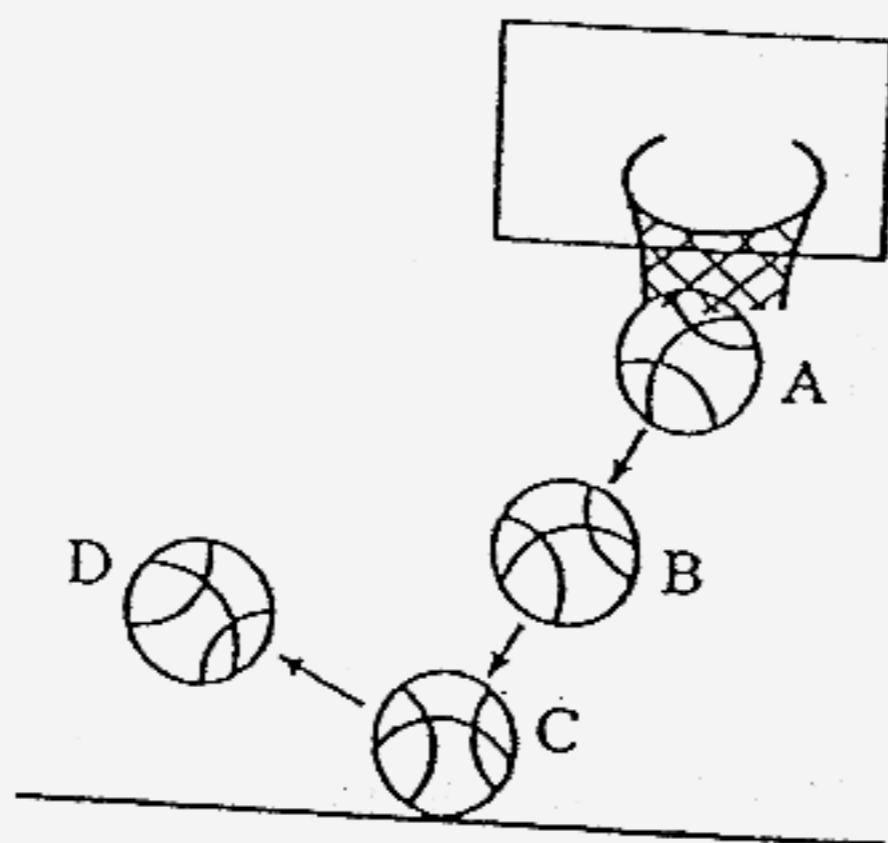

Which one shows the conversion of energy that takes place from A to C?

- (1) Kinetic energy \longrightarrow gravitational potential energy
- (2) Gravitational potential energy \longrightarrow kinetic energy \longrightarrow gravitational potential energy \longrightarrow heat and sound energy
- (3) Gravitational potential energy \longrightarrow kinetic energy \longrightarrow heat and sound energy
- (4) Gravitational potential energy \longrightarrow kinetic energy \longrightarrow heat and sound energy \longrightarrow kinetic energy \longrightarrow gravitational potential energy

28. The table below gives some properties of 4 substances, A, B, C and D.

Substance	Colour	Can it dissolve in water?	Is it a magnetic material?
A	Black	Yes	No
B	Red	No	Yes
C	Black	No	No
D	White	Yes	No

Ali mixes some fine grains of the substances together. He wants to separate them. Which two substances would he have the most difficulty in separating?

- (1) A and C
- (2) A and D
- (3) B and C
- (4) B and D

29. Alex set up the experiment as shown below.

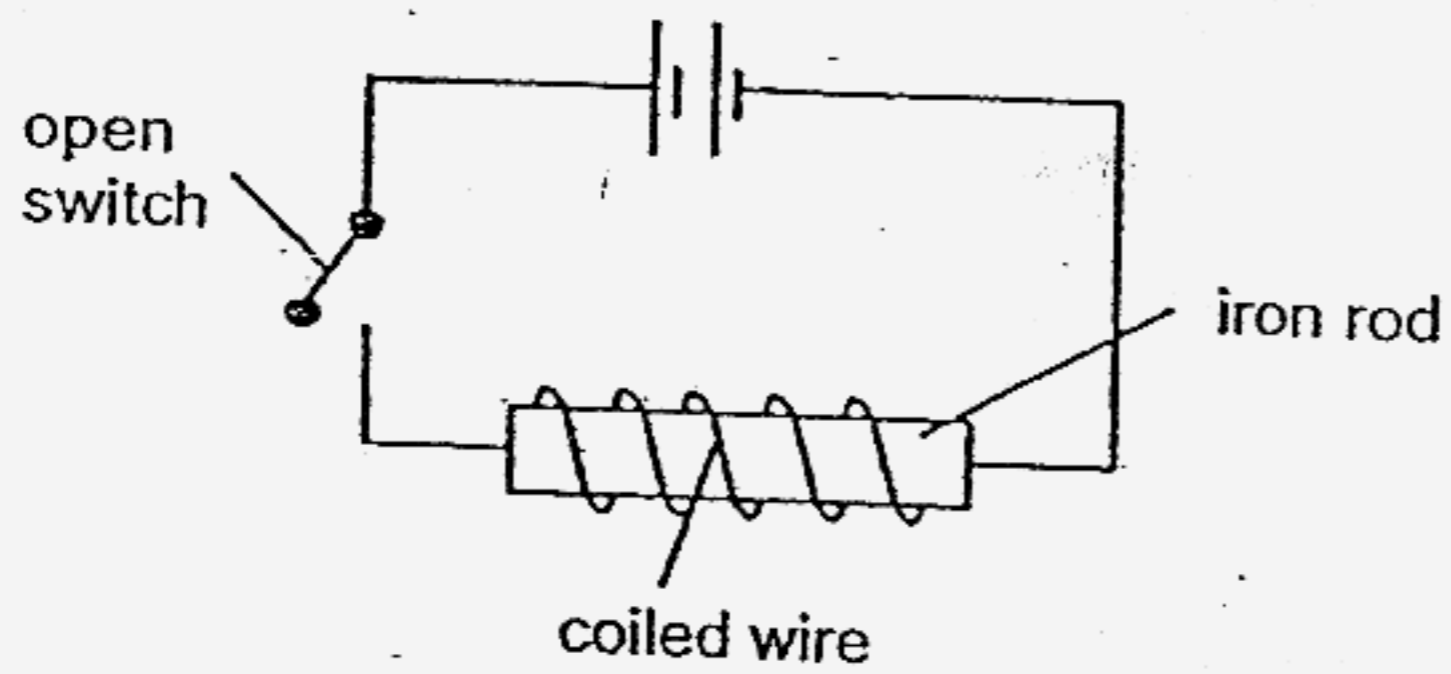

He closed the switch and observed what happened.
Which one of the following diagrams correctly shows what Alex would observe when the steel rod was brought near the iron rod?

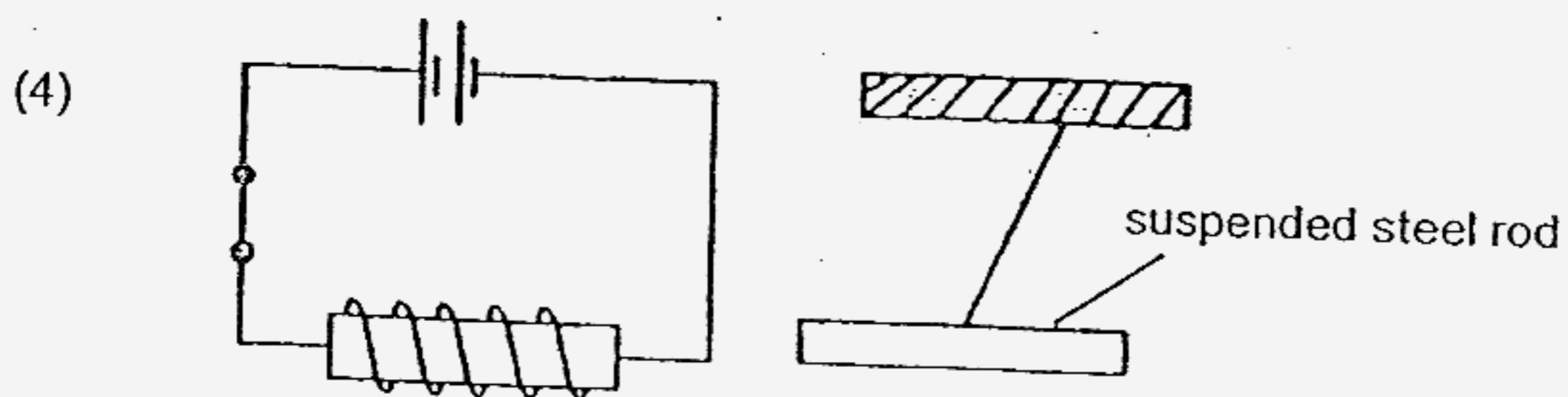
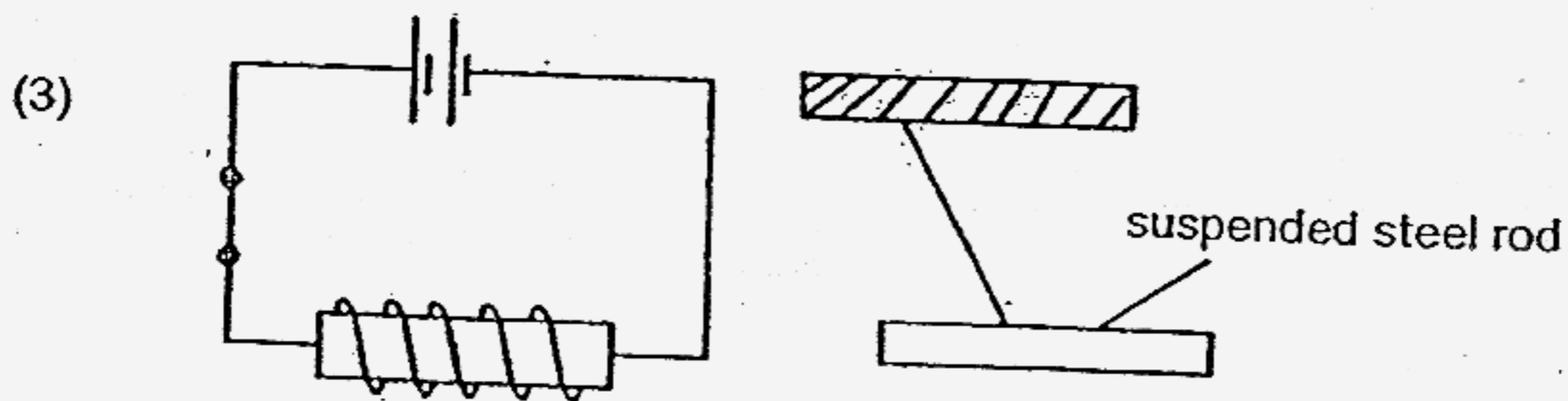
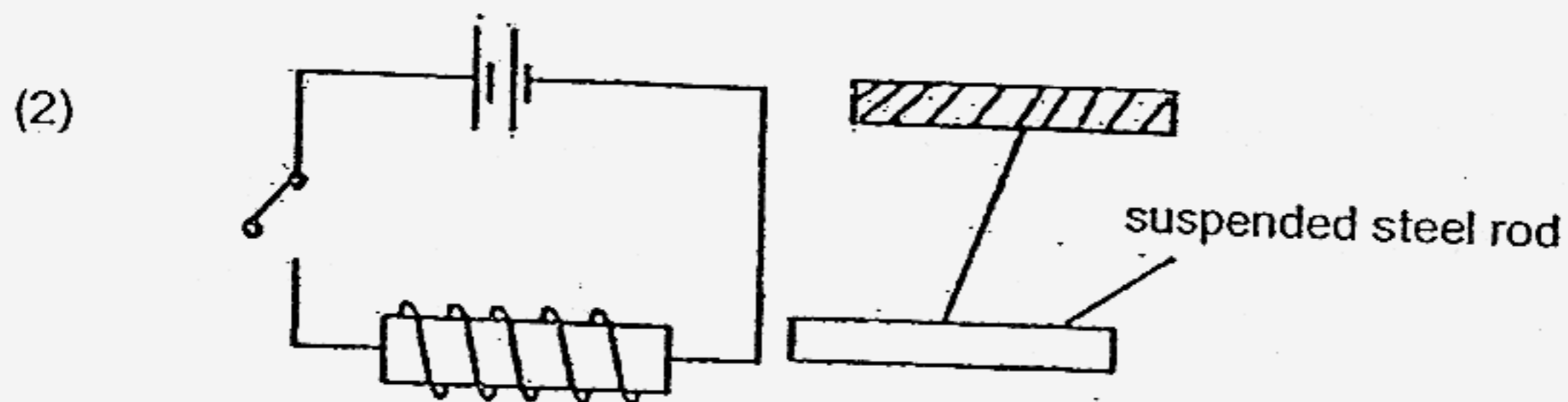
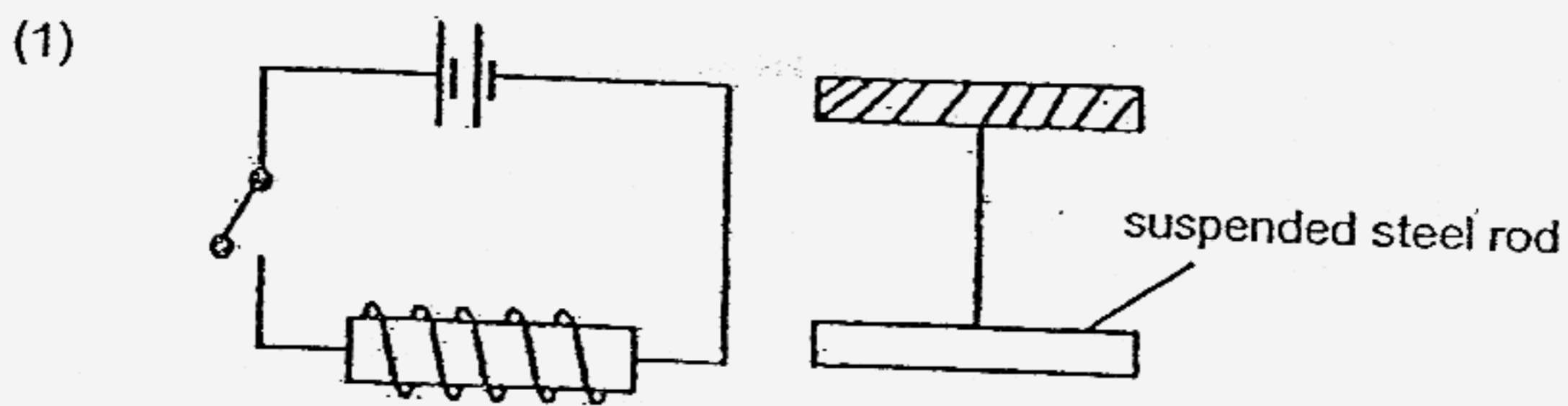

30. A pinwheel was placed on a hollow tin as shown below. When a lighted candle was placed below the hollow tin, the pinwheel began to spin.

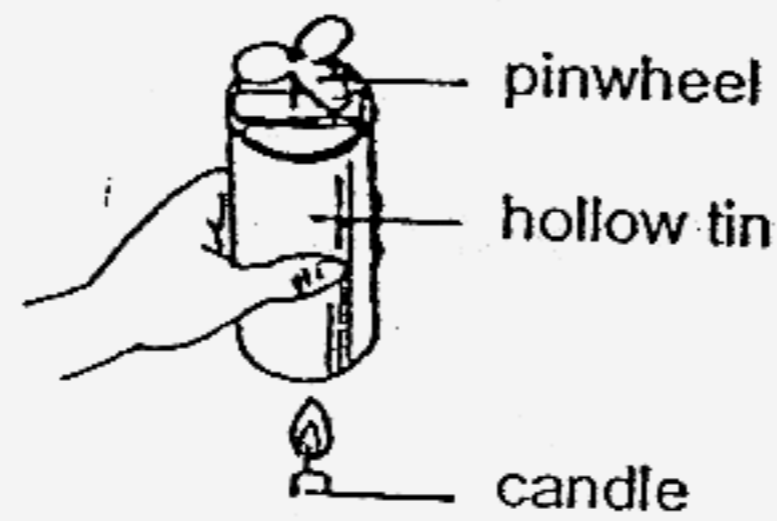

children made the following statements based on what they had observed.

- Bob : The source of energy for the pinwheel to spin is the candle.
Kevin : Light energy from the candle flame causes the pinwheel to spin.
Jane : Hot air rises and kinetic energy of the moving air causes the pinwheel to spin.

Who has made the correct statement?

- (1) Bob and Jane
- (2) Bob and Kevin
- (3) Kevin and Jane
- (4) Bob, Kevin and Jane

PART II (40 marks)

For questions 31 to 46, write your answers in this booklet. The maximum amount of marks available is shown in [] at the end of each question or part-question.

31. Look at the skulls of 2 dinosaurs below carefully.

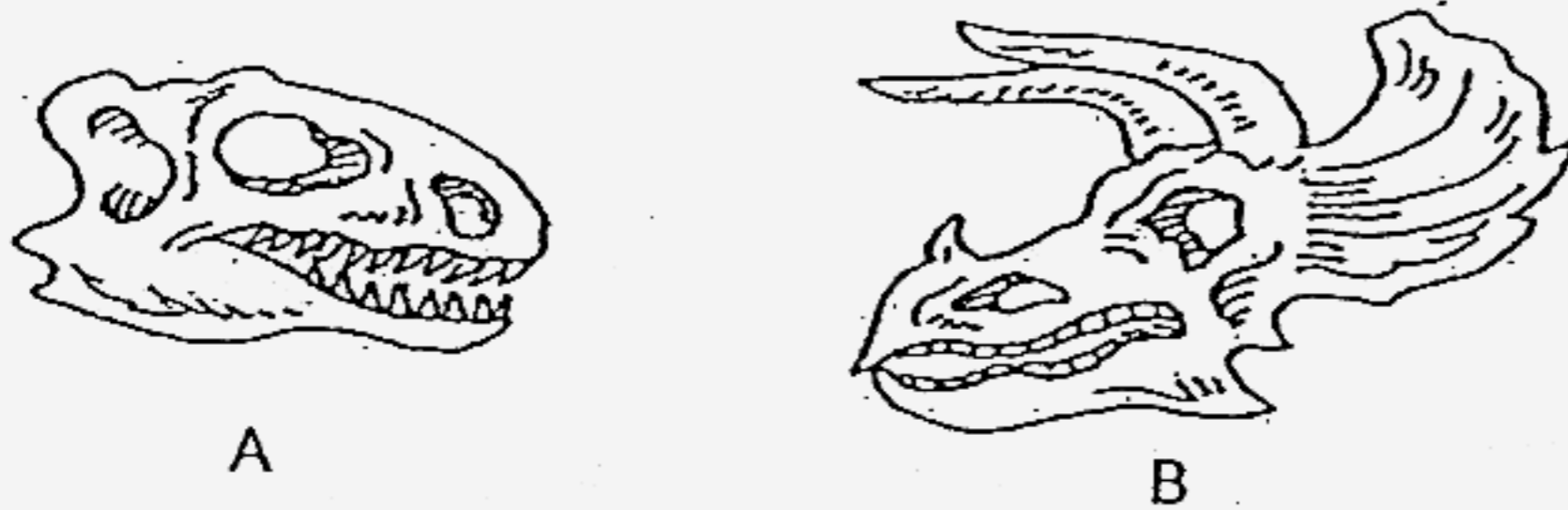

a) Which dinosaur, A or B, was most likely a plant eater? [1]

b) Suggest a reason for your answer. [1]

32. The diagram below shows an aphid feeding from the shoot of a plant. It has fine piercing mouth parts which penetrate and reach a particular tissue for its food.

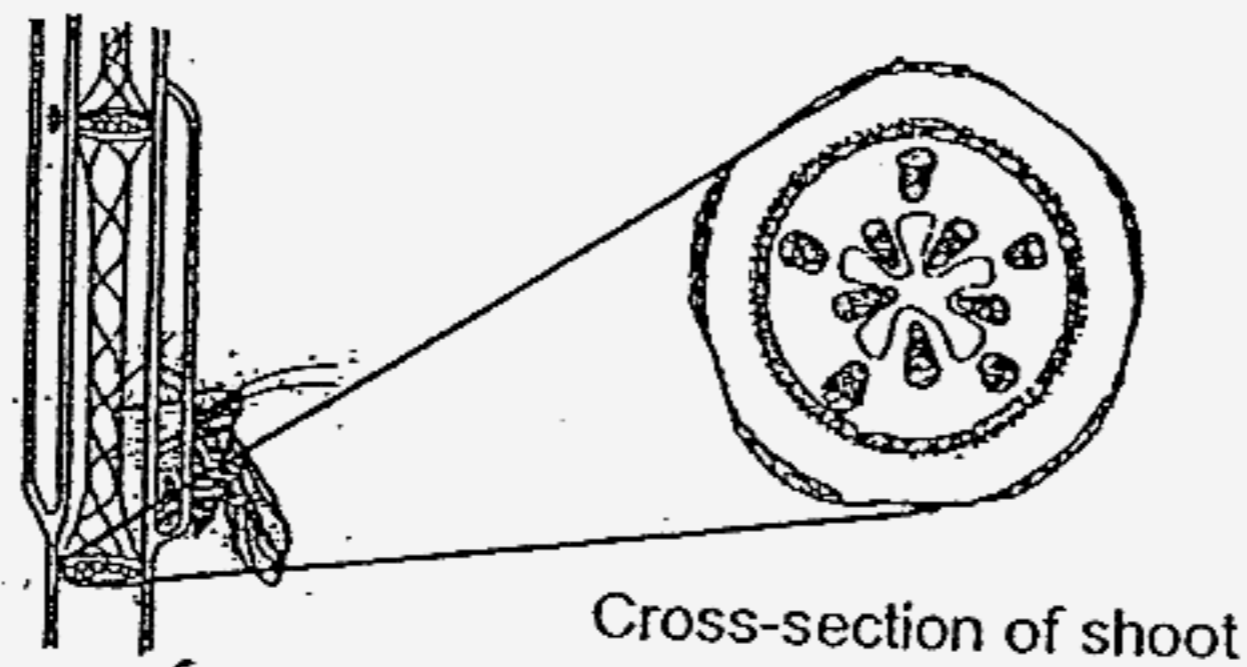

a) Which part of the plant is an aphid most likely to penetrate for food? [1]

b) Name a food substance which could be sucked by the aphid. [1]

c) How can a farmer get rid of aphids without the use of insecticides? [1]

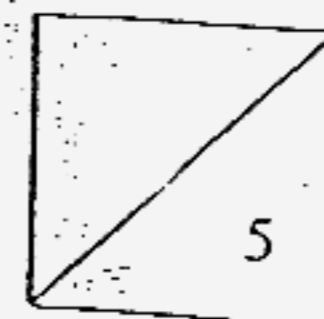

- 33 a) Complete the following concept map about how energy changes in green plants by filling in the 2 boxes. [2]

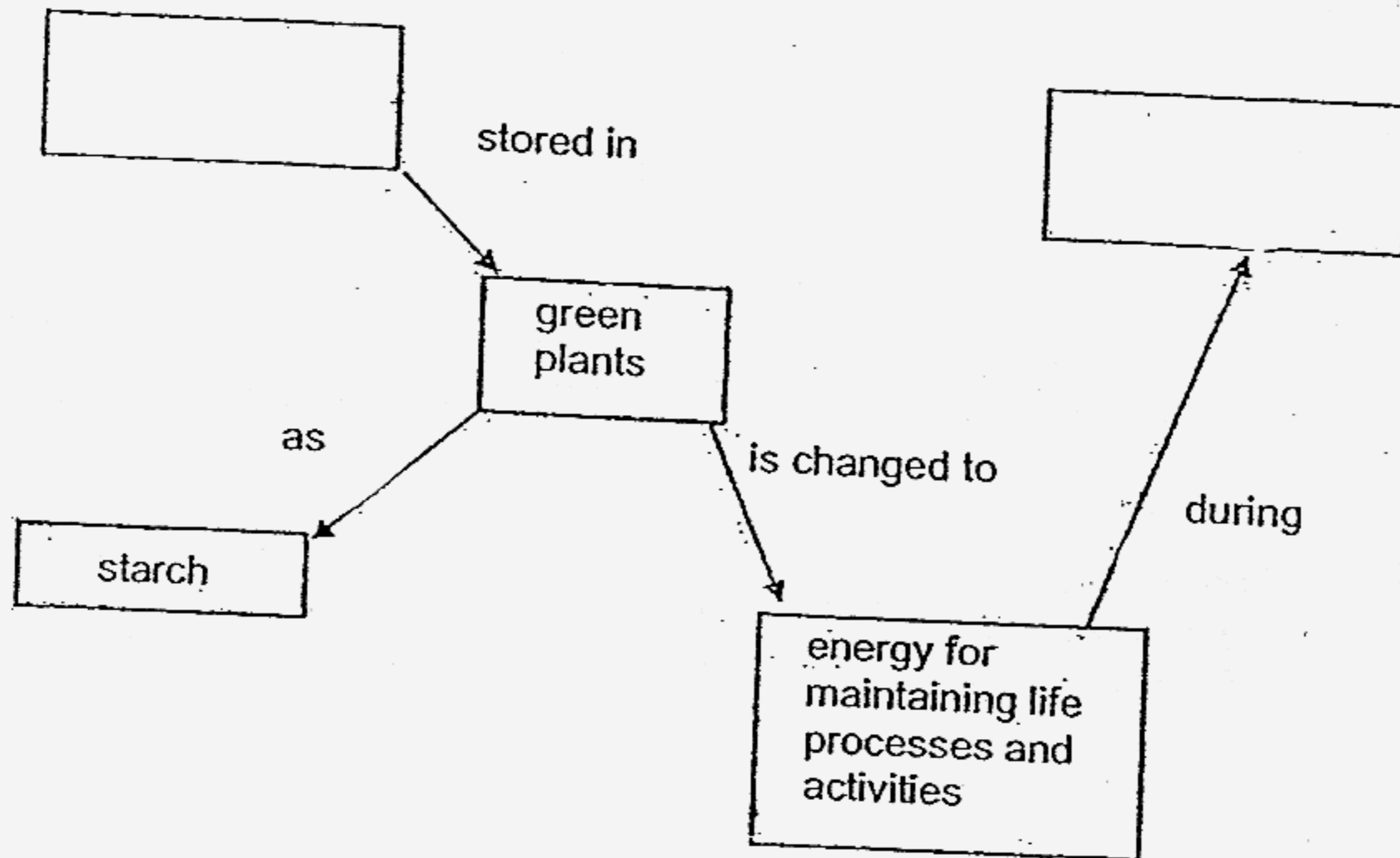

- b) State one difference between photosynthesis and respiration. [1]

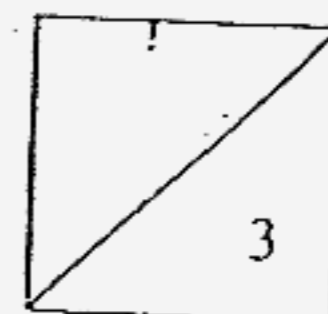

34. A golf course was built next to a forest. Pesticides were used in the golf course to kill off the pests that fed on the grass to ensure that the grass grew well.

The graphs below shows the population of organisms present in the soil of the forest during the first 4 months after the golf course was built.

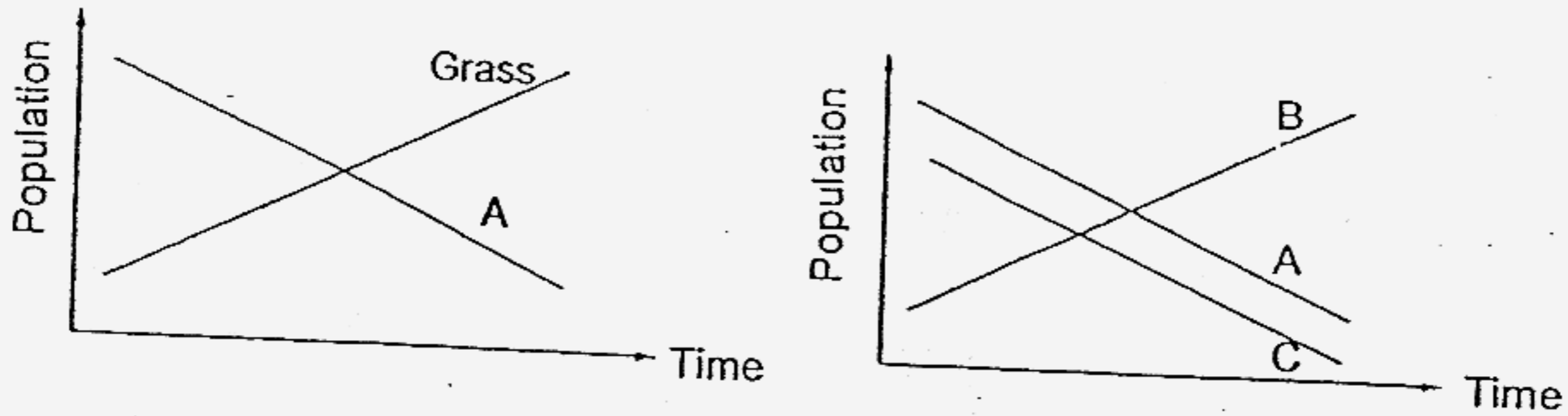

- a) Based on the information given above, suggest a reason for the change in the number of population A. [1]

- b) Construct a simple food chain consisting of at least 2 other organisms to show how the change in the population of grass would affect the ecosystem in the forest. [1]

35. Study the diagram below that shows the relationship among 3 types of organisms carefully and answer the questions that follow.

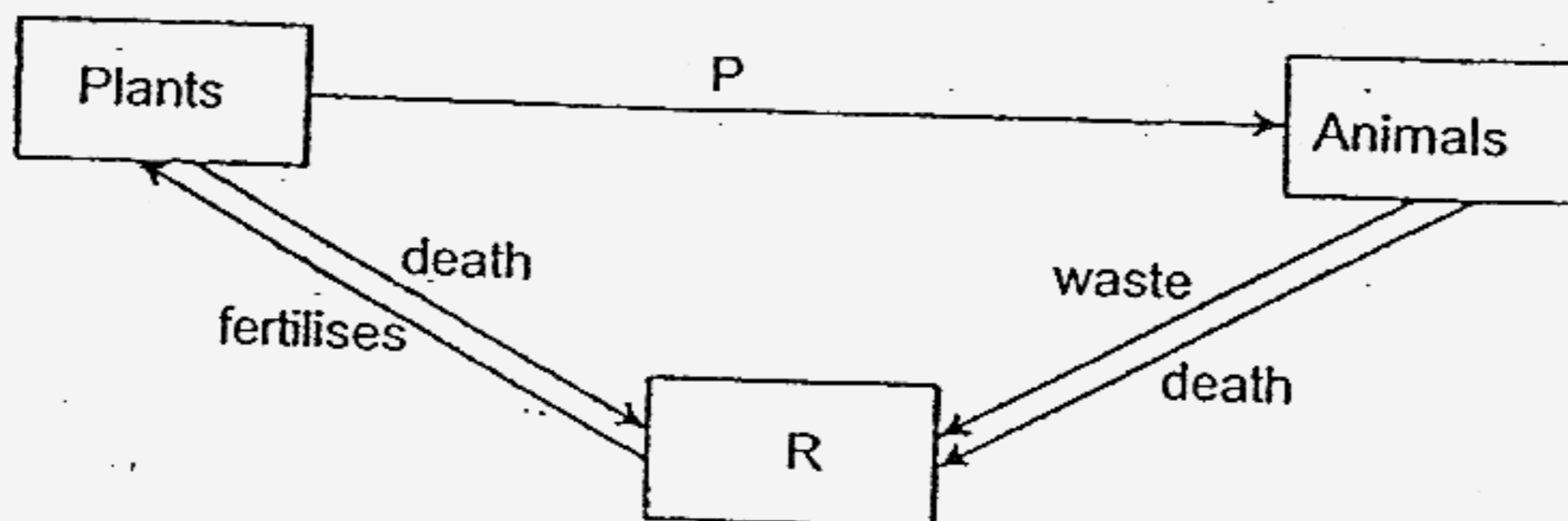

- a) What does the arrow P stand for? [1]

- b) In what way is R important to the ecosystem? [1]

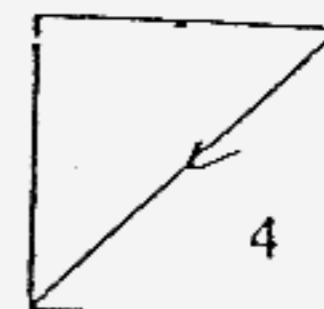

36. The figure below shows how blood flows in a human body.

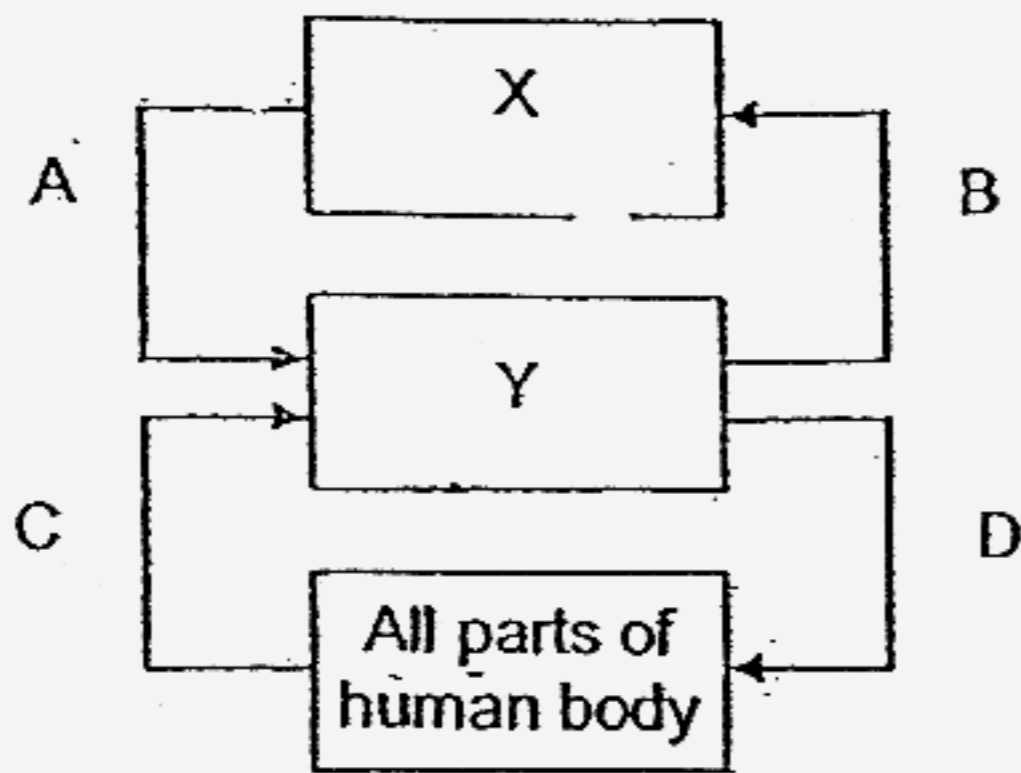

Arrows A, B, C and D represent the movement of blood. Boxes X and Y represent 2 organs.

- a) Organ X: _____ [1]
 Organ Y: _____
- b) Which arrow(s) represent it(s) the movement of blood rich in carbon dioxide? [1]
 Arrow (s) _____

37. Tim wanted to find out how temperature would affect the rate at which a cube of sugar dissolved in water. He placed a cube of sugar into a beaker of water at 25°C and recorded the time taken for the cube of sugar to dissolve completely. He then repeated the experiment with water at different temperatures. His results are shown in the table below.

Temperature of water(°C)	25	35	45	55
Time taken for sugar to dissolve completely(min)	8	6	4	1

- a) Identify the pattern Tim could see between the temperature of the water and the rate at which the cube of sugar to dissolve completely. [1]

- b) Name 2 variables Tim must keep constant in order to make this experiment fair. [1]

- c) Predict the time taken for a cube of sugar to dissolve completely in water at 30°C. [1]

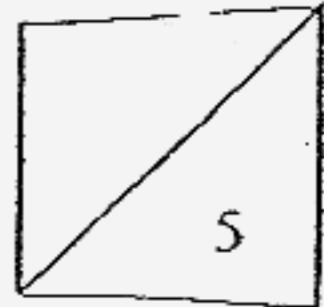

38. David and his friends carried out the experiment below with a wind-dispersed seed. They wanted to find out how the horizontal distance the seed travels will be affected if it is dropped from different heights in front of a small fan.

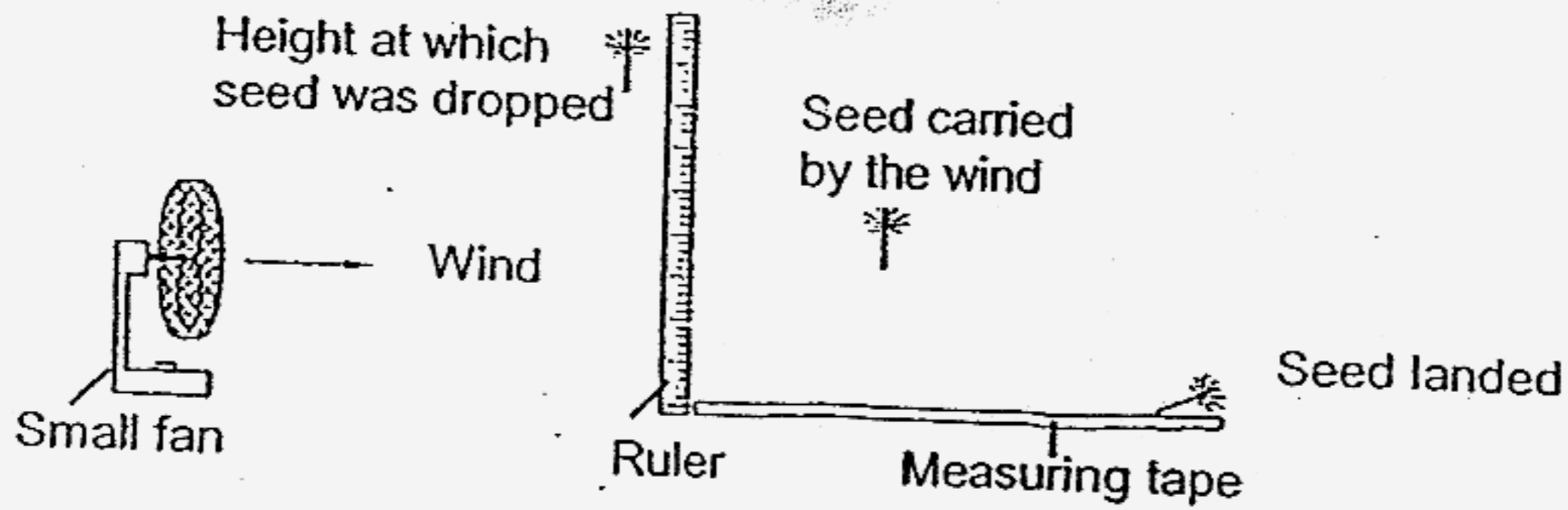

They recorded their results in the table below.

Height above ground (cm)	Horizontal distance travelled by seed (cm)		
	1 st reading	2 nd reading	3 rd reading
5	7	12	11
10	24	19	17
15	27	29	34
20	41	43	36
25	49	54	47

Based on the above results, plot a line graph of the height above the ground at which the seed was released against the average horizontal distance travelled by the seed in the graph below. [3]

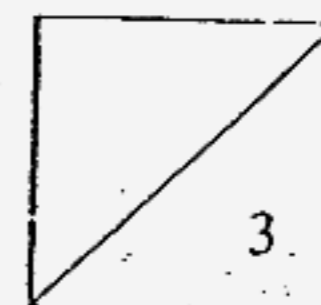
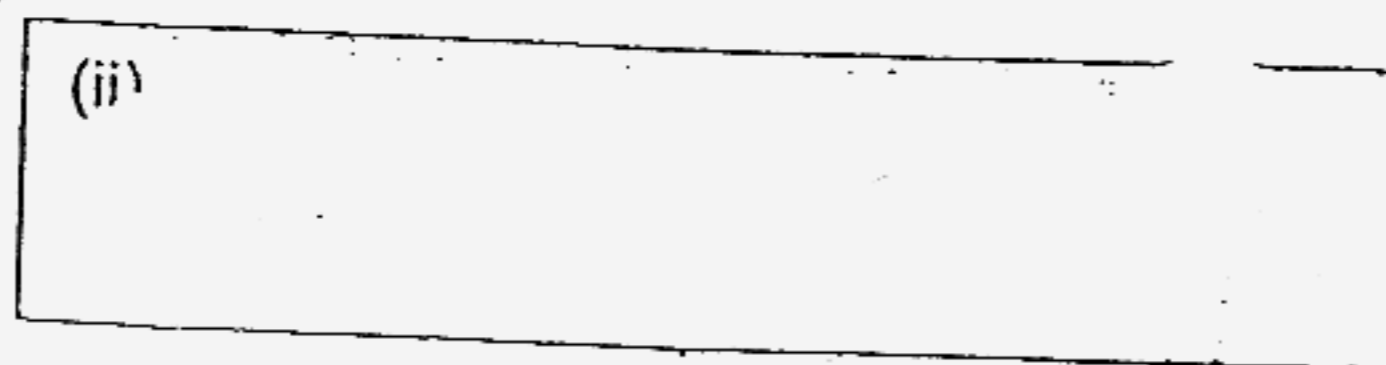
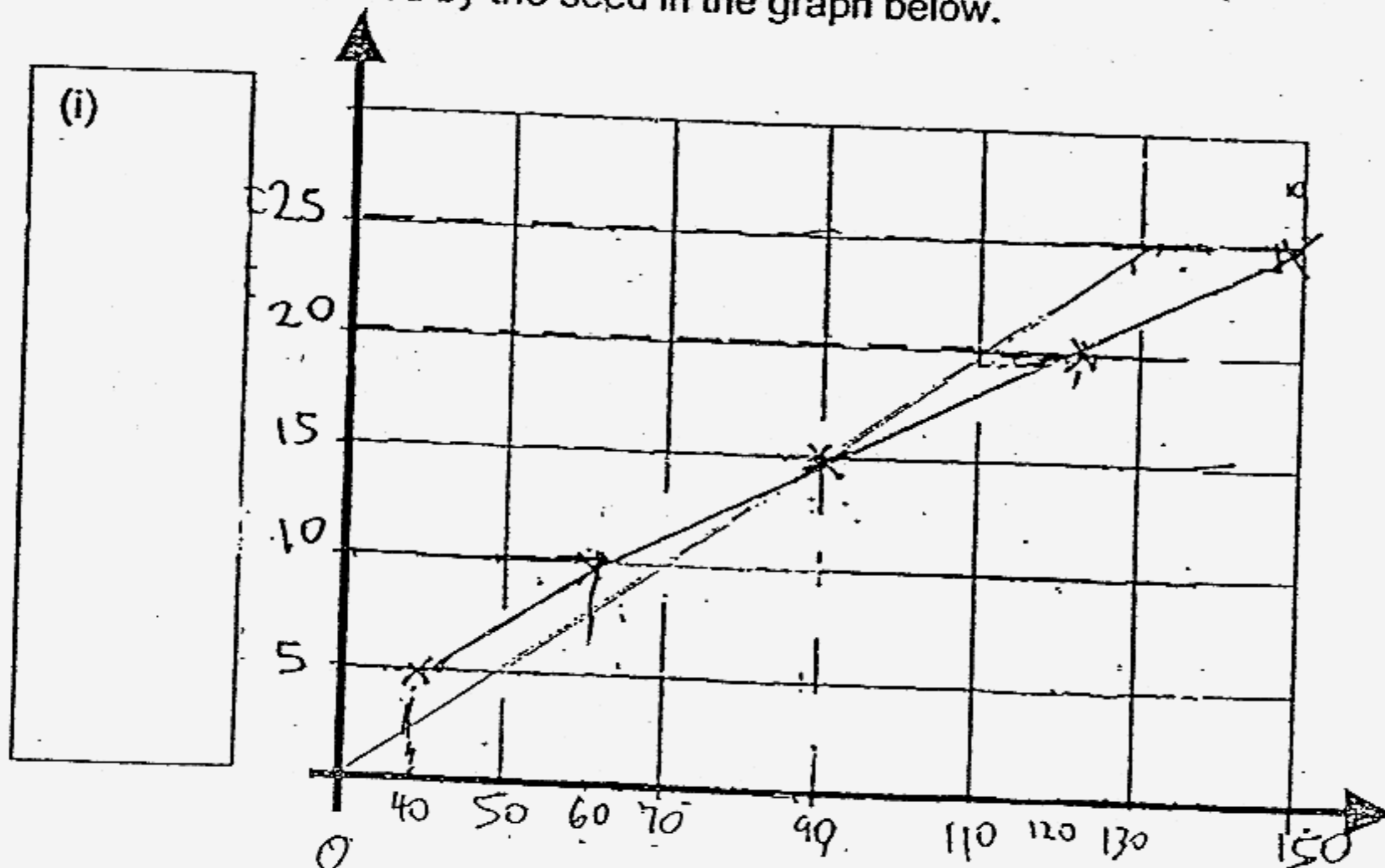

39. Study the diagram below. When Tom placed object P near the magnet, the rubber ball was pushed off the table.

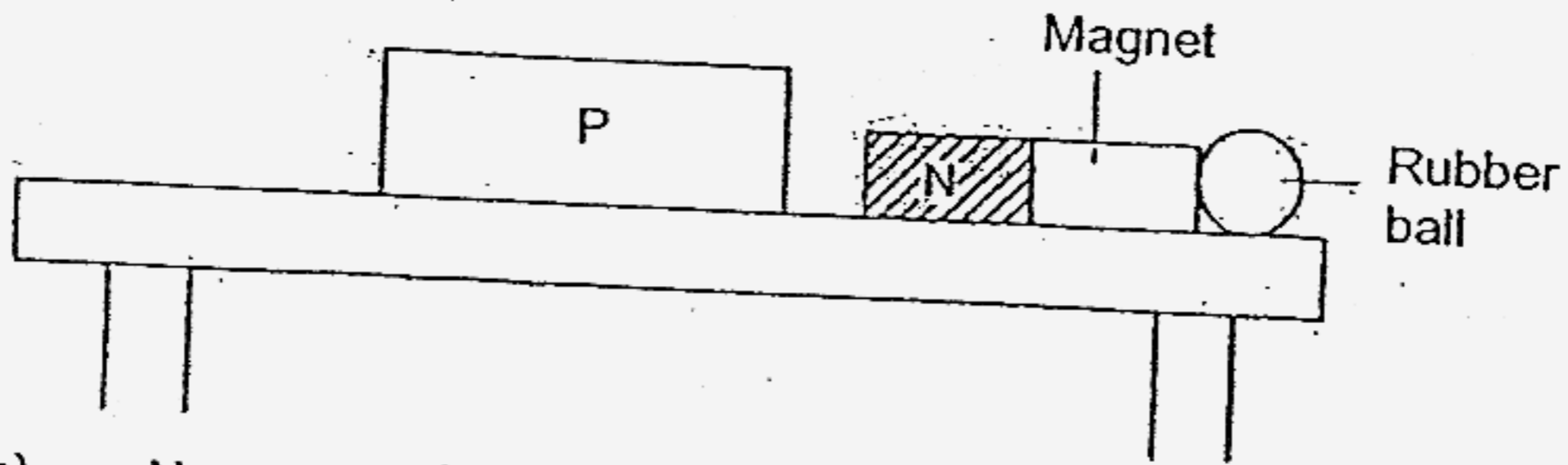

- a) Name 2 forces that caused the rubber ball to fall from the table to the ground. [1]
-
- b) State a material that is used to make object P. [1]
-
40. The diagram below shows the position of the Moon between the Earth and the Sun on 16 June 2006. The Earth, Moon and Sun form a straight line when viewed from the North Pole of the Earth.

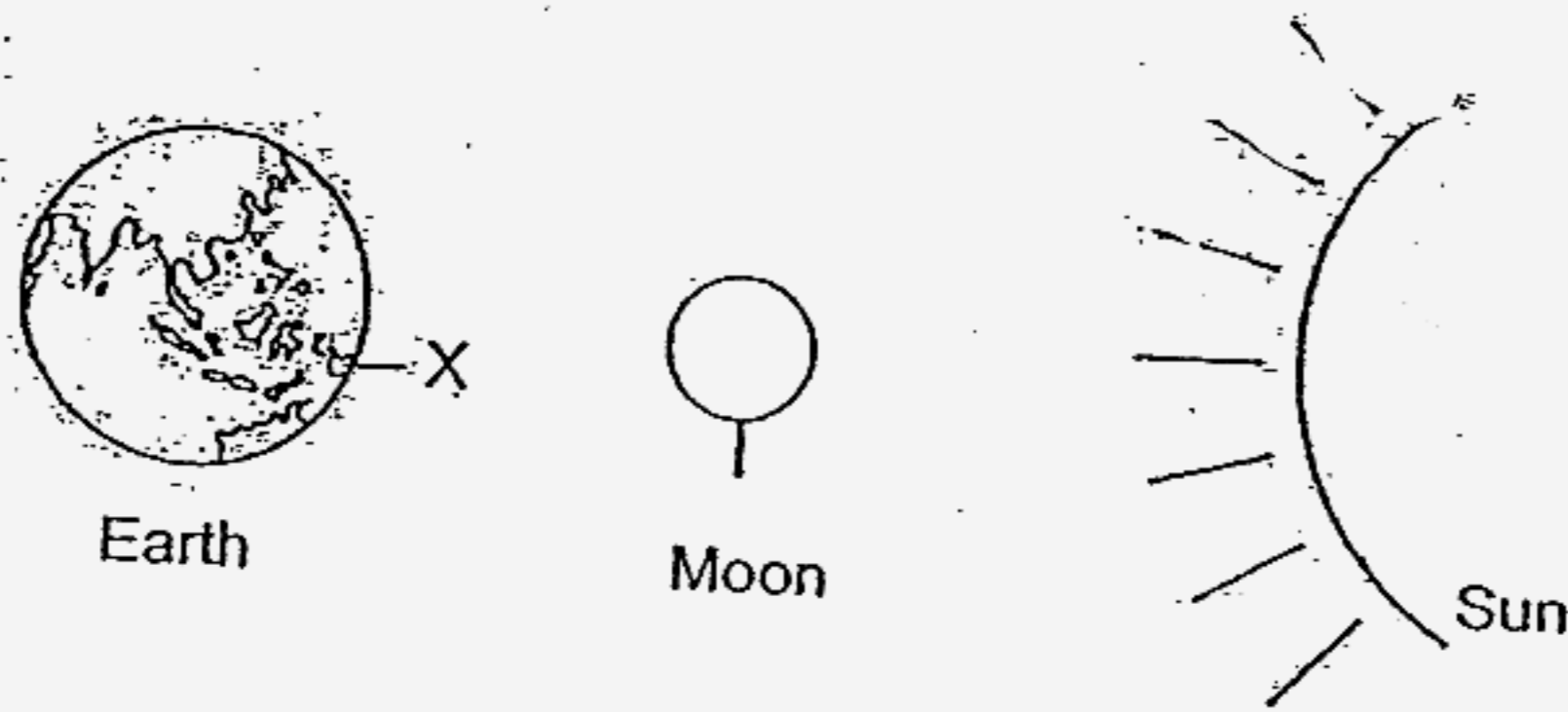

Alvin lives in Country X as shown in the diagram above.

- a) Name the phase of the moon seen by Alvin when he looked up at the sky on the night of 16 June 2006. [1]
-
- b) At which date would Alvin see the earliest full Moon? [1]
-

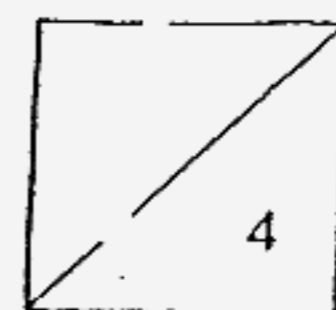

41. Jenny accidentally poured some iron filings and sand into a beaker of salt solution. State the methods she can use to separate the three substances in the following sequence. [3]

Steps	Description	What is separated?
Step 1		Iron filings
Step 2		Sand
Step 3		Salt

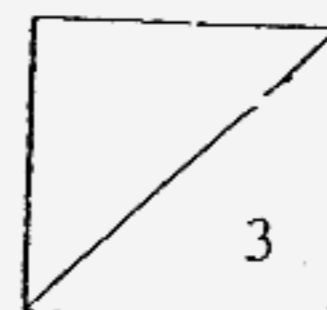

42. Jasper set up an experiment as shown below.

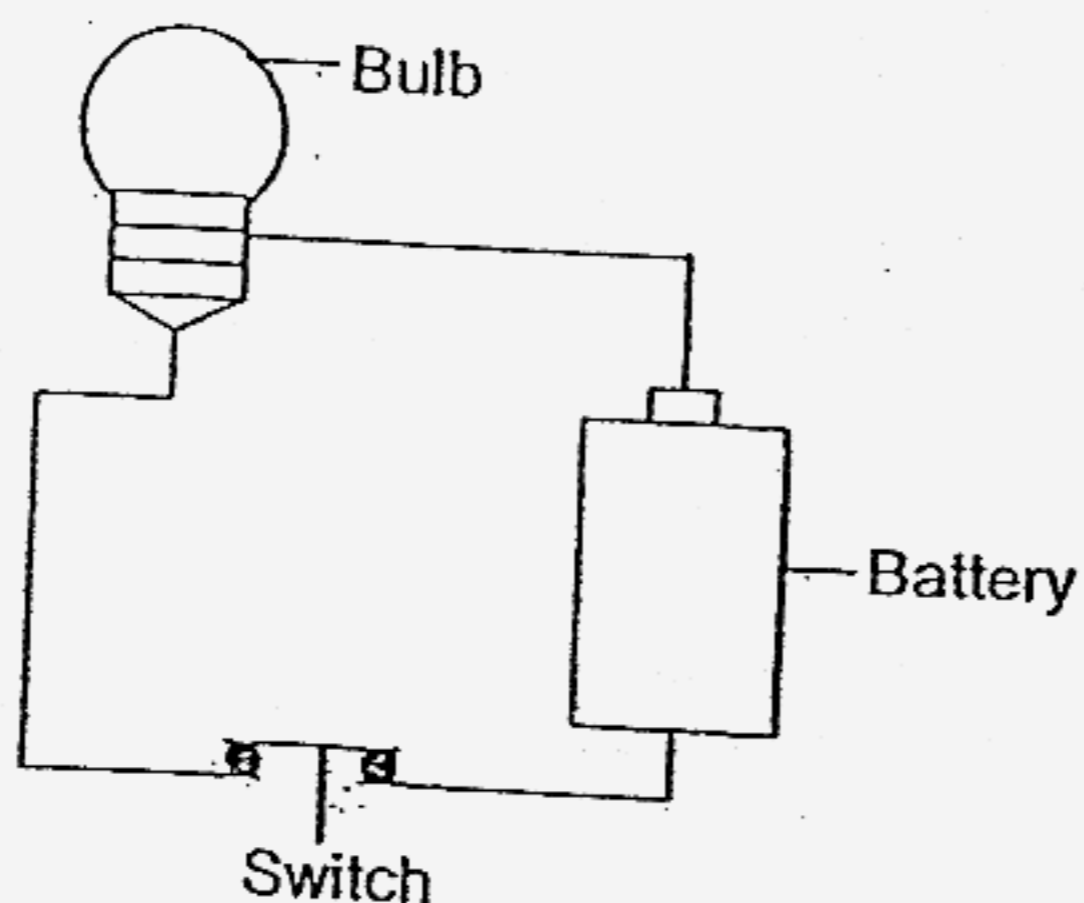

He repeated the experiment with different number of batteries. The results of this experiment are represented by the graph shown below.

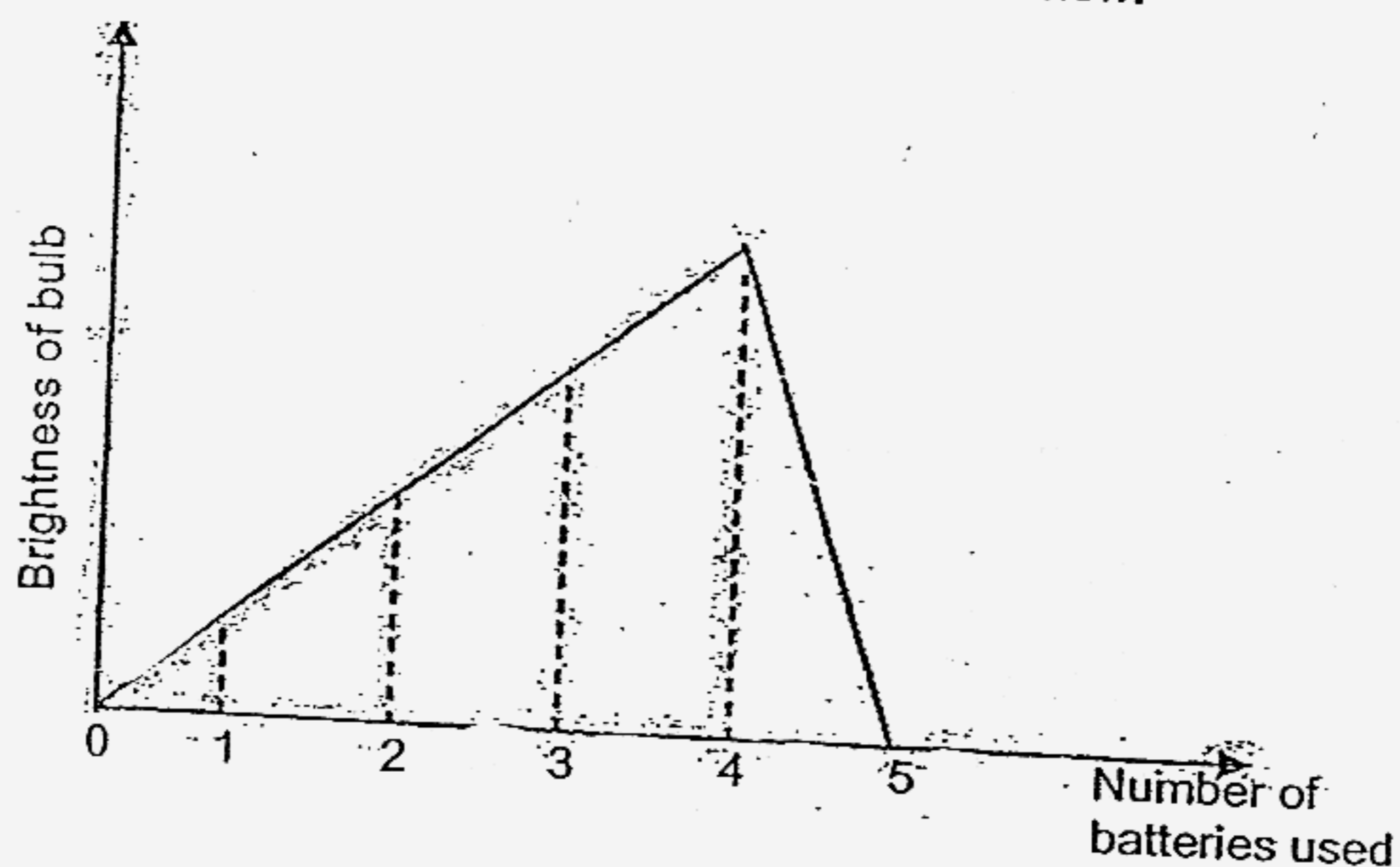

- a) What was Jasper trying to find out from the above experiment? [1]
- _____
- _____
- b) What happened to the brightness of the bulb when 3 batteries instead of 1 battery were used? [1]
- _____
- c) What happened to the bulb when the 5th battery was added to the closed circuit above? [1]
- _____

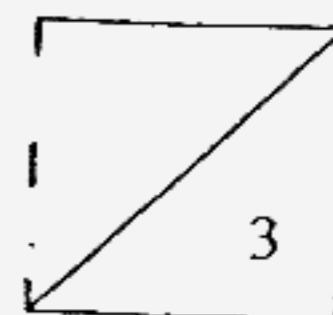

43. The diagram below shows a sharp bend along a 2-way road.

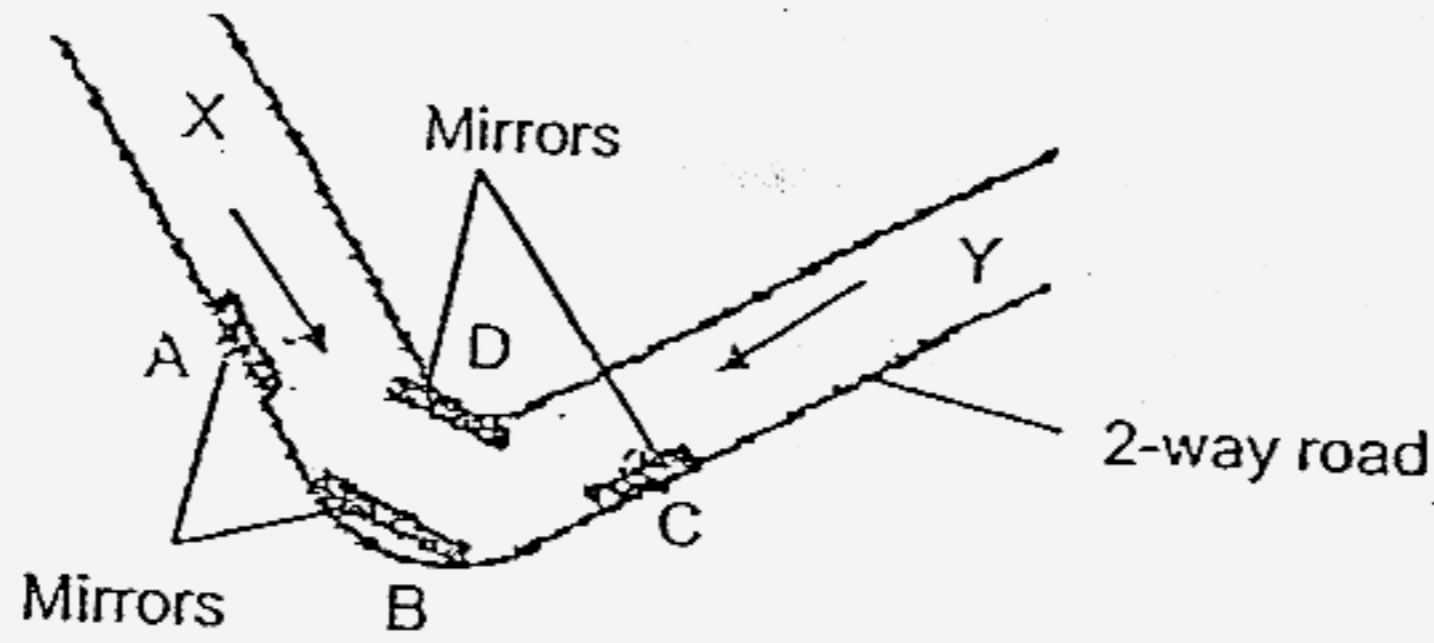

- a) Which mirror, A, B, C or D, will enable motorists coming from X and Y to see each other before they meet? [1]
-
- b) Explain how the mirror enables motorists to see each other before they meet.
-
- c) State the property of light which allows this setup to work. [1]
-

44. Sally stepped on an empty drink can and crushed it.



- a) State one effect the force had done to the empty can. [1]
-
- b) Comment on the weight of the can before and after it was crushed and state the reason. [1]
-

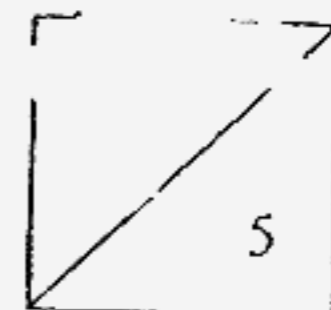

45. Study the 2 gear systems below.

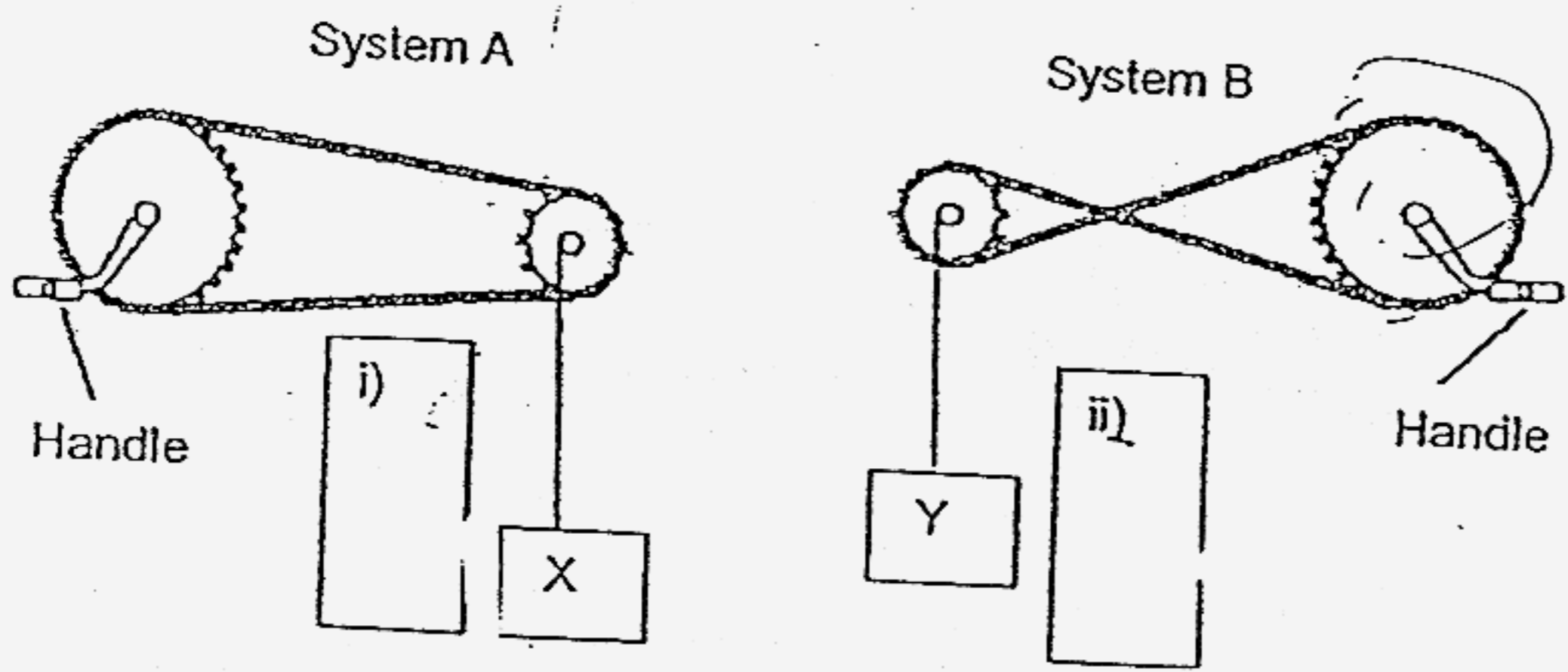

- a) If the handles of both systems are turned clockwise, the loads X and Y will also move. Using an \rightarrow , draw the direction of their movements in the boxes (i) and (ii) provided. [1]
- b) State and explain how these gear systems make work easier. [2]

Advantage : _____

Reason : _____

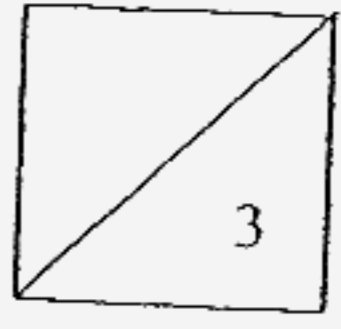

46. Thomas built a catapult using rubber bands, ice-cream sticks and a spoon, as shown in the diagram below.

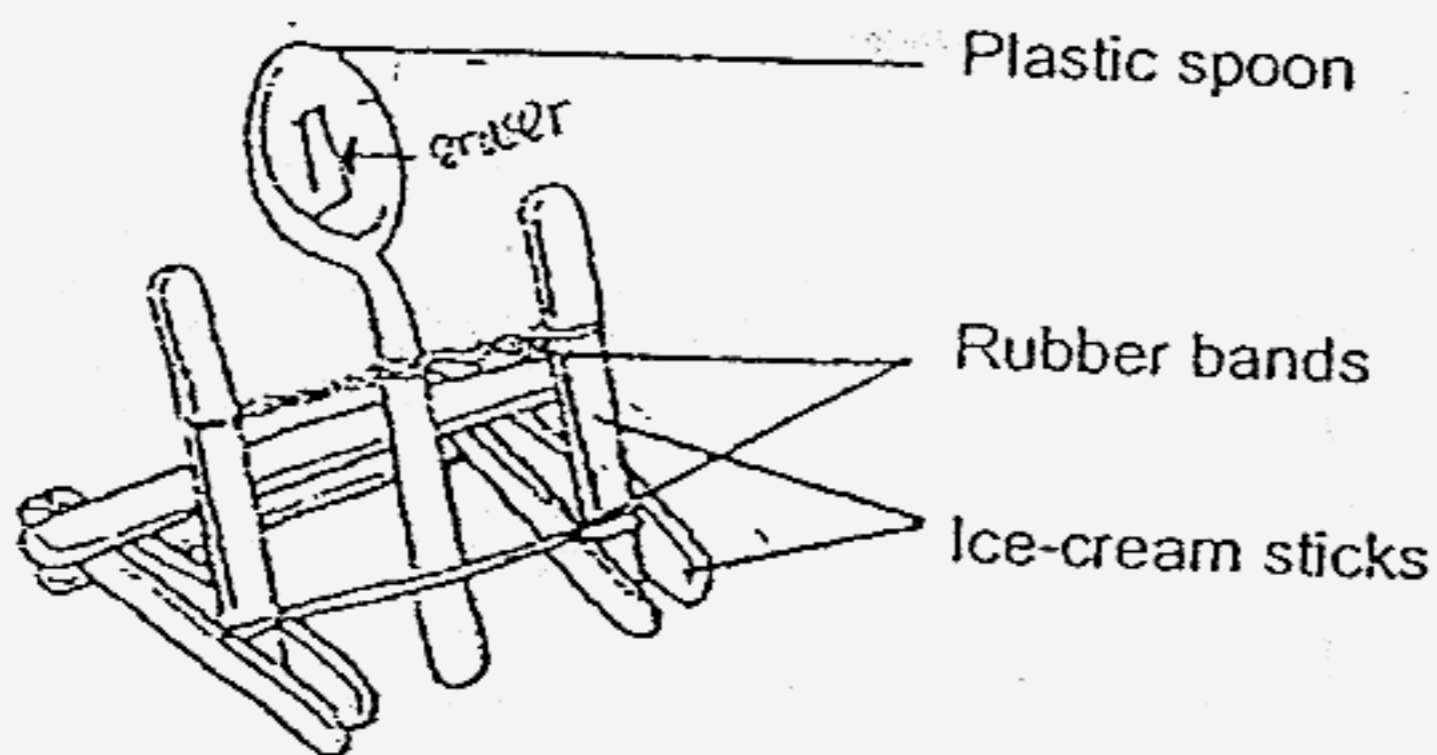

Using the catapult, he shot a piece of eraser to a distance by placing the eraser on the spoon, pushing the spoon in the direction indicated by the arrow as shown in the diagram and finally letting go of the spoon.

- a) Suggest 1 way Thomas can change the catapult such that he can shoot the same eraser further without changing the spoon. [1]

- b) Fill in the boxes the energy conversion that had taken place as Thomas released the spoon to shoot the eraser. [1]

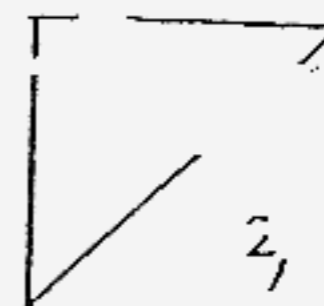
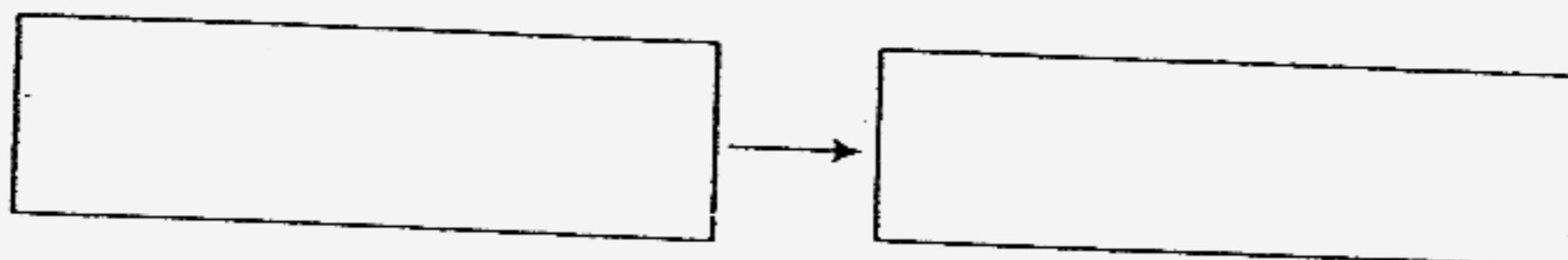

SECTION A : (60 MARKS)

Qn no.	Ans
1	3
2	4
3	1
4	1
5	2
6	2
7	4
8	4
9	1
10	4

Qn no.	Ans
11	3
12	2
13	4
14	4
15	1
16	4
17	3
18	2
19	4
20	4

Qn no.	Ans
21	3
22	2
23	2
24	4
25	3
26	3
27	3
28	2
29	4
30	1

SECTION B (40 MARKS)

Qn No.	Answers
31a	B
31b	It has blunt teeth which is adapted for grinding plants.

32a	Phloem tubes
32b	Sugar
32c	Introduce ladybirds into the farms

33a	Sugar \longrightarrow in green plants energy for maintaining life processing and activates \longrightarrow respiration.
33b	Photosynthesis take place in the presence of sunlight but respiration take place anytime.

34a	Pesticide seeped into soil and killed the organisms.
34b	Grass \longrightarrow A \longrightarrow C

35a	It stands for 'eaten by'.
35b	It breaks down dead matter into simpler substances or nutrients for plant growth.

36a	Organ X : Lungs Lungs Y : Heart
36b	C , B

37a	The higher the temperature of water, the lesser time the sugar will take to dissolve completely.
37b	1) The same amount of water 2) The same amount of the cube of sugar.
37c	7 minutes

38a (i)	Horizon distance traveled by seed (cm)
(ii)	Height above ground (cm)

39a	Magnetic forced of repulsion
39b	Iron

40a	New moon
40b	30 June 2006

41a	Step 1 : use a magnet. Bring it next to the beaker and leave it there. The iron fillings will get attracted to it. Slowly pull up the fillings until it reacted the top of the bearer and out of it.
	Step 2 : Pour the mixture into a filter paper
	Step 3 : put the beaker above a burning candle and wait for the water to evaporate. The salt will be left in the beaker until all the water is evaporate.

42a	He was trying to find out the number of batteries used affects the brightness of the bulb.
42b	The brightness of the bulb increases.
42c	The bulb fuses. Too much electricity was supplied to the bulb.

43a	B
43b	The reflection of the motorist in mirror A and C would be reflected on D which will be then reflected to B.
43c	Light travels in straight line.

44a	It changes the shape of the can.
44b	The weight of the can before and after it was crushed still remain the same. Only the shape and size changes.

45a (i)	↑
(ii)	↓
45b	The load travels a longer distance, so the effort required is lesser.
46a	Add more rubber bands
46b	Elastic potential → kinetic energy.