



UNIVERSITY OF CAMBRIDGE INTERNATIONAL EXAMINATIONS
General Certificate of Education Ordinary Level

CANDIDATE
NAME

CENTRE
NUMBER

--	--	--	--

CANDIDATE
NUMBER

--	--	--	--



WOODWORK

6030/01

Paper 1 Theory, Drawing and Design

October/November 2009

2 hours 45 minutes

Candidates answer Section I Part A on the Question Paper.

- Additional Materials:
- A2 Drawing Paper (1 sheet)
 - Answer Paper
 - Coloured crayons
 - Metric scale rule, scale 1:5
 - Standard drawing equipment

READ THESE INSTRUCTIONS FIRST

Write your Centre number, candidate number and name on all the work you hand in.
Write in dark blue or black pen.
You may use a soft pencil for any diagrams, graphs or rough working.
Do not use staples, paper clips, highlighters, glue or correction fluid.
DO NOT WRITE IN ANY BARCODES.

Section I Part A

Answer **all** parts of Section I Part A.
Write your answers in the spaces provided on the Question Paper.

Section I Part B

Answer any **two** questions.
Write your answers on the separate Answer Paper provided.

Section II

Answer **all** parts of this section.
Use the A2 sheet of Drawing Paper prepared prior to the examination for your answers.
All dimensions are in millimetres.
At the end of the examination, fasten all your work securely together.
The number of marks is given in brackets [] at the end of each question or part question.

For Examiner's Use	
Section IA	
Section IB	9
	10
	11
	12
Section II	
TOTAL	

This document consists of **10** printed pages and **2** blank pages.



Section I Part A

Answer **all** questions from this Part in the spaces provided on the question paper.

You are advised to spend no longer than 35 minutes on this Part.

1 Fig. 1 shows a piece of wood which has been marked out to width and length.

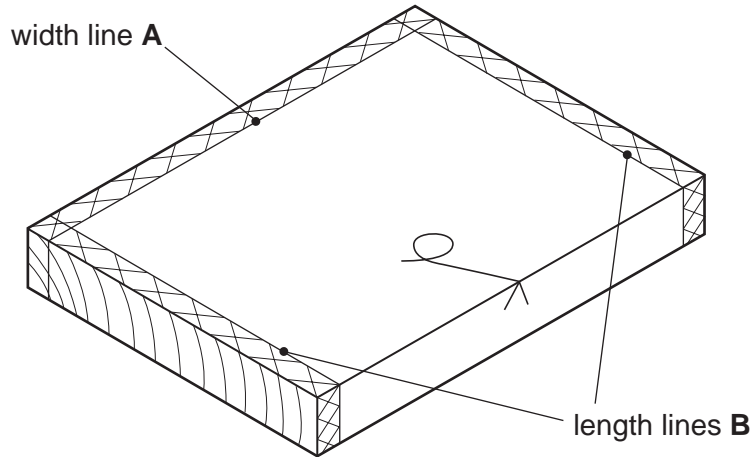

Fig. 1

(a) Name the marking out tools you would use to mark:

(i) width line A

(ii) length lines B [2]

(b) Name the tools you could use to cut down to:

(i) line A

(ii) line B [2]

2 Give **two** personal safety rules which must always be obeyed when handling sharp edged tools, such as chisels.

Rule 1

.....

Rule 2

..... [2]

3 Fig. 2 shows a board which has been converted from a log.

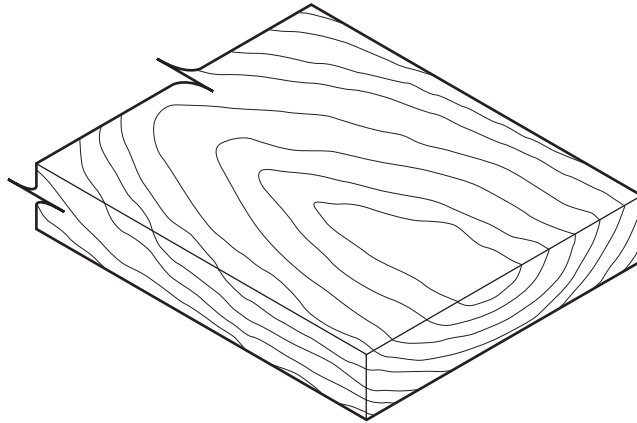

Fig. 2

On Fig. 2 show how the following defects would appear on the board.

A cup shake

A thunder shake

An end split or check

[3]

4 Fig. 3 shows three joints used in construction.

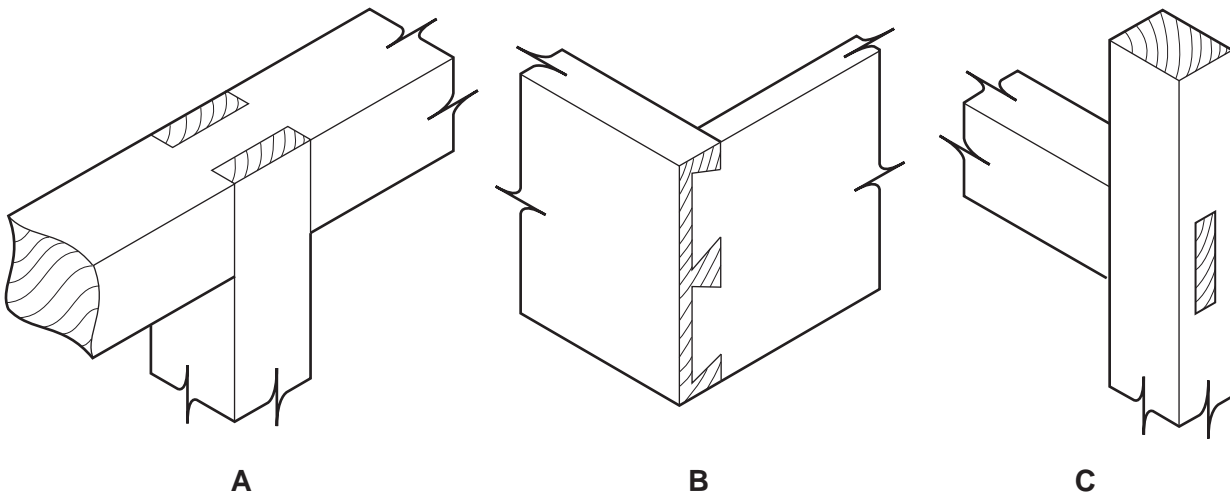

Fig. 3

Name each joint.

Joint A

Joint B

Joint C [3]

5 Fig. 4 shows a board with a thin layer of hardwood to be used for a table top.

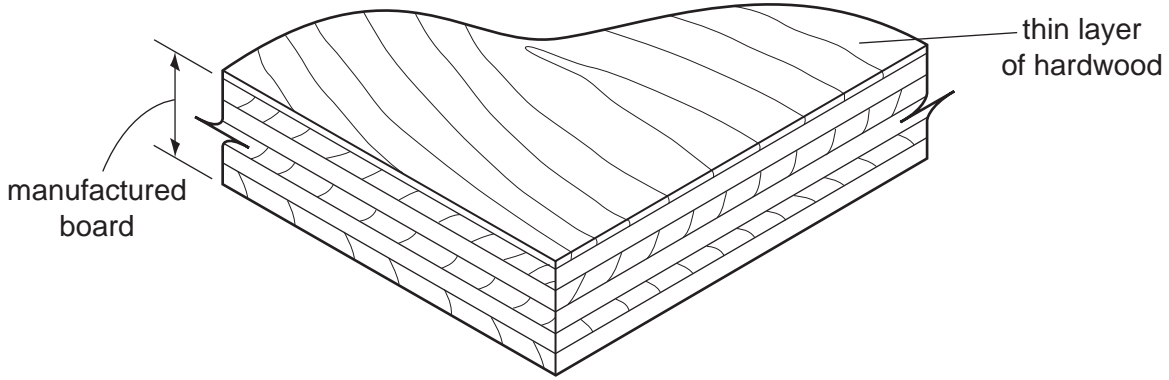

Fig. 4

(a) Name the thin layer of decorative hardwood used on the top surface.

.....

(b) Name the manufactured board shown.

.....

(c) Name an adhesive which would be suitable to glue the thin layer of hardwood to the manufactured board.

..... [3]

6 Fig. 5 shows two saws used to cut wood.

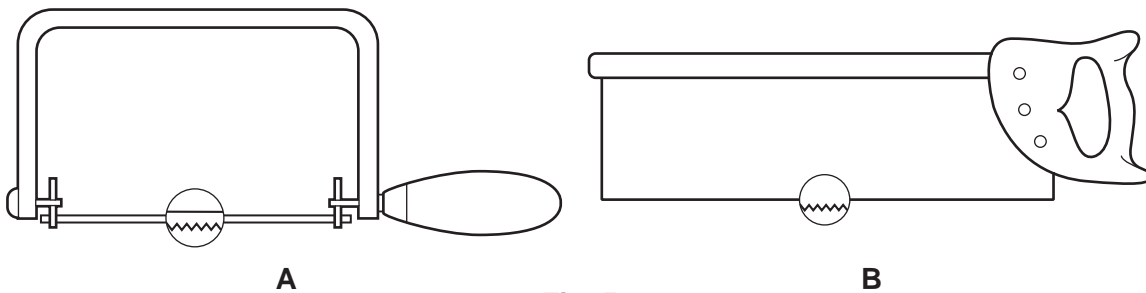

Fig. 5

(a) Name each saw.

Saw A

Saw B [2]

(b) Name the specific use of each saw.

Use of Saw A

Use of Saw B [2]

7 Timber has to go through several stages from the tree to the board, ready for use in the workshop.

Name the process of:

(a) cutting down the tree;

(b) cutting the log into boards;

(c) drying the timber, ready for use. [3]

8 Name the fixings shown in Fig. 6.

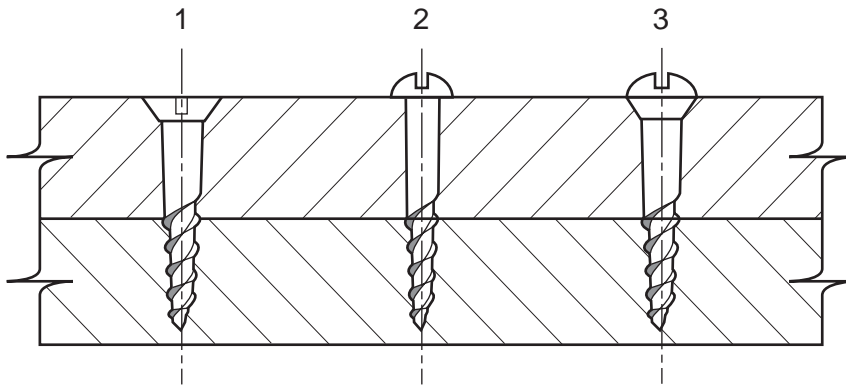

Fig. 6

Fixing 1

Fixing 2

Fixing 3 [3]

Section I Part B

Answer any **two** questions from this Part on the separate answer paper provided.

You are advised to spend no longer than 35 minutes on this Part.

- 9 Fig. 7 shows a joint used in construction.

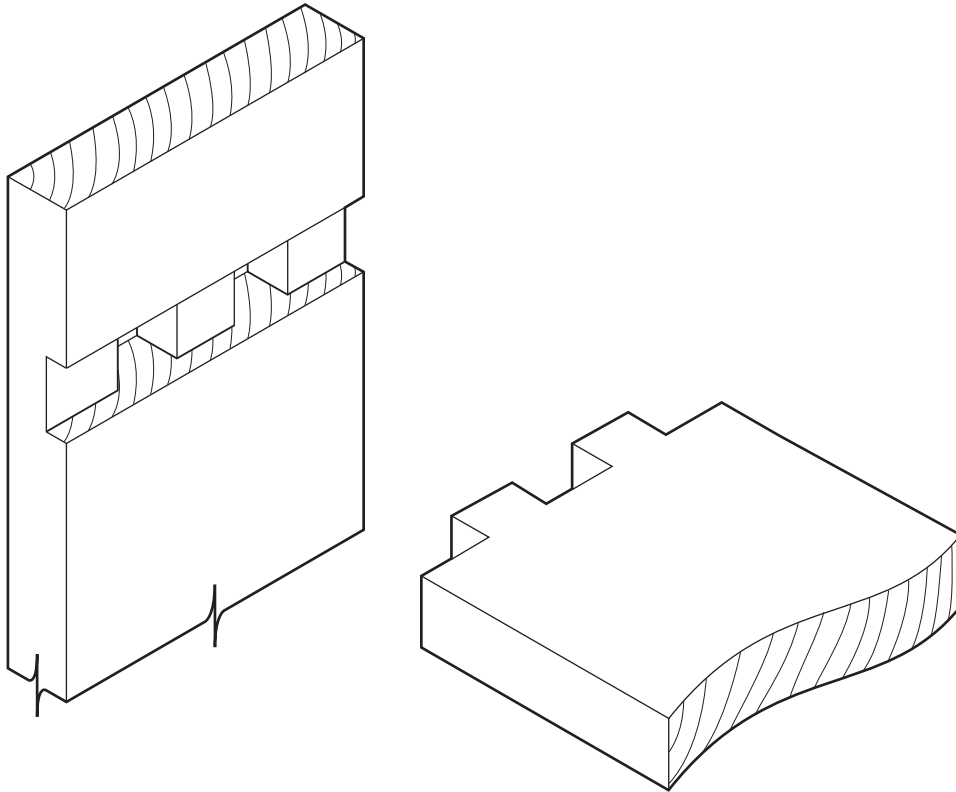

Fig. 7

- (a) Name the joint. [2]
- (b) Use notes and sketches to describe how you would:
- (i) mark out both parts of the joint; [4]
- (ii) cut both parts of the joint. [6]

Make sure you name all tools used.

10 Fig. 8 shows a book shelf which is to be fixed to a wall.

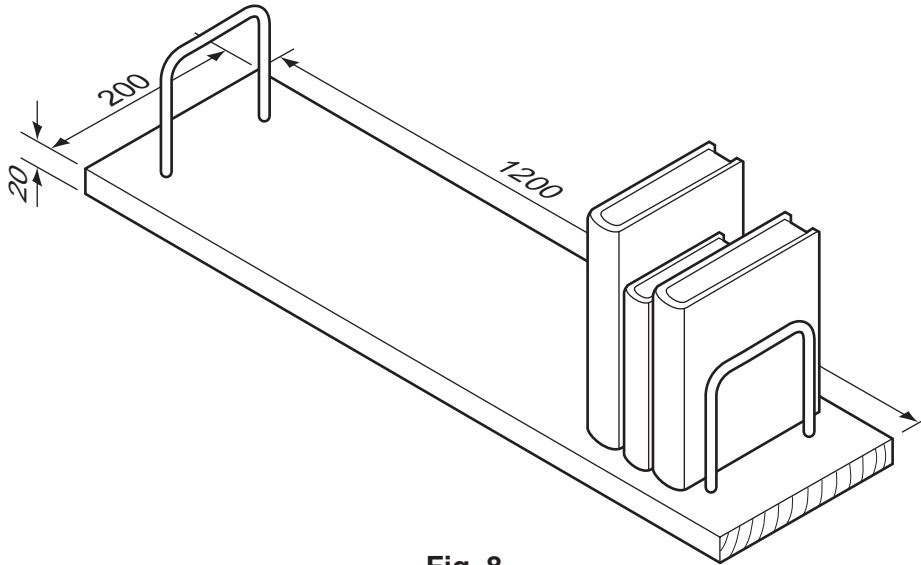

Fig. 8

The shelf is made from solid wood. Use notes and sketches to describe how you could make modifications to the shelf.

(a) Show **two** methods of keeping the shelf flat along the grain. [8]

(b) Show **one** method of keeping the shelf flat across the grain. [4]

Include materials and sizes.

11 Fig. 9 shows a candle holder to be used as a table decoration.

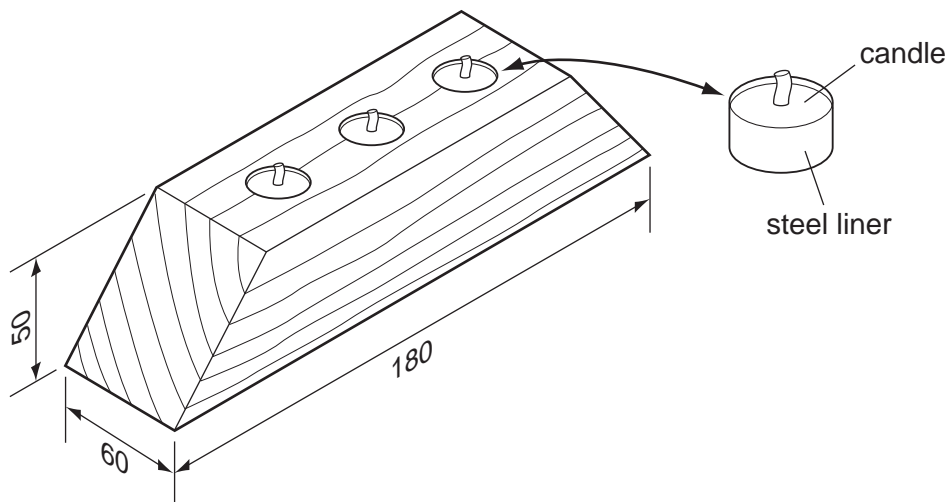

Fig. 9

Use notes and sketches to describe how you would:

(a) mark out one of the angles on the piece of hardwood; [4]

(b) cut one of the angles; [4]

(c) clean up one of the side surfaces and one of the angles ready to apply a finish. [4]

Name all the tools used and methods of holding.

12 Fig. 10 shows a door which is to be glued together.

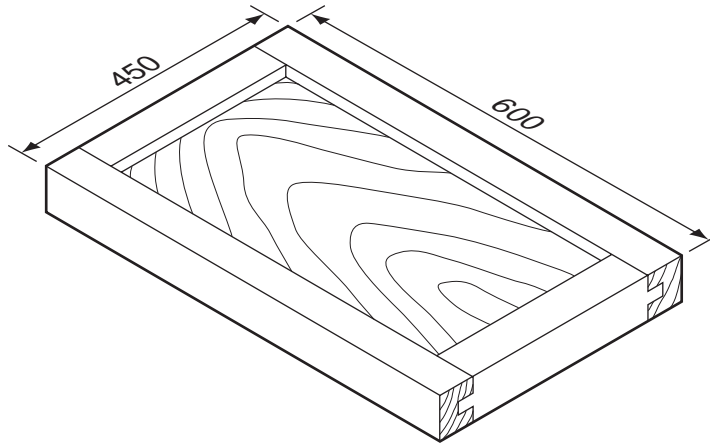

Fig. 10

Use notes and sketches to describe how you would prepare the door for gluing, after all the joints have been cut. Include details of how you would:

- (a) prepare the door to ensure it will fit together before gluing; [4]
- (b) apply adhesive to the joints; [2]
- (c) pull the joints together while the glued joints set; [3]
- (d) test the frame for flatness and squareness. [3]

BLANK PAGE

Section II starts on page 10, overleaf

Section II Drawing and Design

Answer **all** questions from this Part on the previously prepared drawing paper.

Use **one** side of the drawing paper only.

You will be required to draw part of this section to a scale of 1:5.

You are advised to spend 1 hour 35 minutes on this Section.

The pictorial sketch Fig. 11 on page 11 shows details of a kitchen food preparation table. Any sizes not shown are left to your discretion. The table is to have a drawer in each end, the front of one is indicated. The drawers are to be of traditional construction.

Drawer details: Front $300 \times 120 \times 20$, Sides $350 \times 100 \times 15$, Back 90 wide, 15 thick.

Part C

To the right of the vertical line on your paper, sketch freehand and approximately full size:

- (i) an exploded view of the joint you would use to join the underframe to the leg at **A**; [8]
- (ii) a design for a handle or pull for the drawer front; [5]
- (iii) any shaping to parts of the framework. [3]

Part D

(a) Draw in first or third angle projection, using a scale of 1:5 (hidden detail is not required):

- (i) a front view in the direction of arrow **Y**; [10]
- (ii) a sectional end view on the line **XX**; [10]
- (iii) a plan. [3]

(b) Add to your drawing **six** main dimensions. [3]

(c) In the Title Box include the following details in suitable lettering:

- (i) a title;
- (ii) your name;
- (iii) your examination number;
- (iv) the projection you have used. [3]

Marks for layout. [2]

Marks for quality. [3]

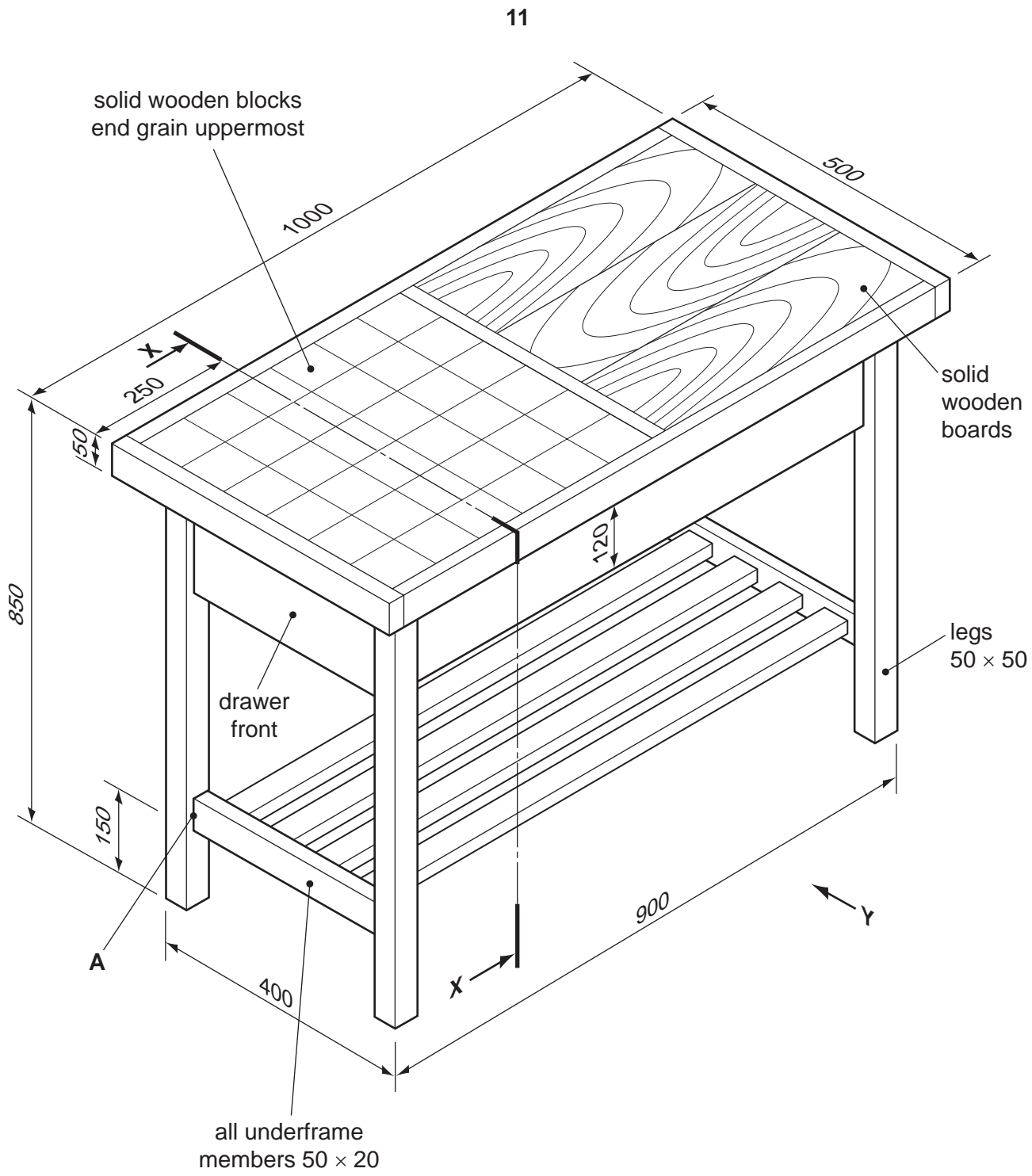

Fig. 11

Permission to reproduce items where third-party owned material protected by copyright is included has been sought and cleared where possible. Every reasonable effort has been made by the publisher (UCLES) to trace copyright holders, but if any items requiring clearance have unwittingly been included the publisher will be pleased to make amends at the earliest possible opportunity.

University of Cambridge International Examinations is part of the Cambridge Assessment Group. Cambridge Assessment is the brand name of University of Cambridge Local Examinations Syndicate (UCLES), which is itself a department of the University of Cambridge.