



UNIVERSITY OF CAMBRIDGE INTERNATIONAL EXAMINATIONS
General Certificate of Education Ordinary Level

WOODWORK

6030/01

6030/02

October/November 2007

CONFIDENTIAL INSTRUCTIONS

Great care should be taken to ensure that any confidential information given does not reach the candidates either directly or indirectly.

READ THESE INSTRUCTIONS FIRST

Information to be given to the candidates

On receipt of these instructions, candidates are to be informed that for Paper 1, Section II (Drawing and Design) they are to be conversant with framed construction and will be given the opportunity to display their ability as designers in wood.

The practical test requires knowledge of carcass construction.

The papers are in metric dimensions.

This document consists of **3** printed pages and **1** blank page.



Section II (DRAWING AND DESIGN)

Each candidate will require **one piece of good quality A2** drawing paper. This should be ruled out as below before the examination.

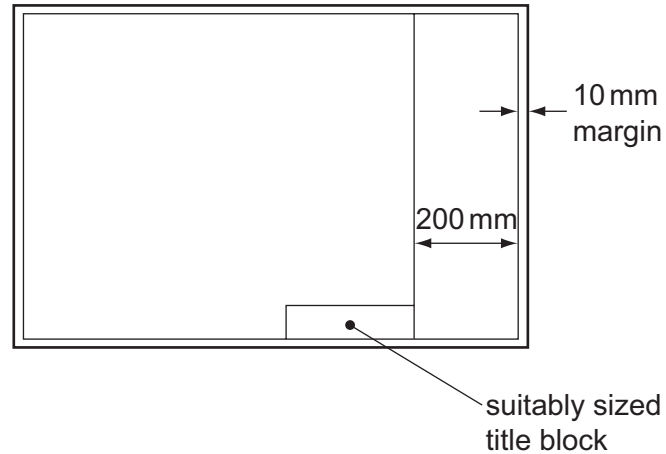

In addition to the normal drawing office equipment, each candidate will require a metric scale rule reading a scale of 1:5.

Supervisors are reminded that the use of colour is to be encouraged where appropriate in this paper, and of the need to check the quality of all drawing equipment before the examination.

Paper 2 Practical Test 6030/02

All materials for the practical test are to be supplied locally. They will not be supplied by the Syndicate. Supervisors should endeavour to obtain the materials specified. When this is not possible, the Supervisor is requested to enclose, with the test pieces, a list of the sizes supplied.

In addition to the usual bench kit, the following tools will be required:

(a) Between **two** candidates:

Pencil compass.

Adjustable bevel set to slope of 1:6 or dovetail template set to 1:6.

6 mm and 12 mm bevel-edged chisels.

A finely set smoothing plane.

A coping saw.

(b) Between **four** candidates:

12 mm or 15 mm scribing gouge (inside ground).

Each candidate is to be supplied with the materials listed below. The wood, which should be a mild-working and a straight-grained hardwood such as the candidates are accustomed to using, must be planed and the ends shot to the dimensions shown. This work is to be carried out by the candidates prior to the examination.

One piece 130 long planed to 90 wide and 23 thick.

One piece 450 long planed to 70 wide and 12 thick.

BLANK PAGE

Permission to reproduce items where third-party owned material protected by copyright is included has been sought and cleared where possible. Every reasonable effort has been made by the publisher (UCLES) to trace copyright holders, but if any items requiring clearance have unwittingly been included, the publisher will be pleased to make amends at the earliest possible opportunity.

University of Cambridge International Examinations is part of the Cambridge Assessment Group. Cambridge Assessment is the brand name of University of Cambridge Local Examinations Syndicate (UCLES), which is itself a department of the University of Cambridge.