

Centre Number	Candidate Number	Name
---------------	------------------	------

UNIVERSITY OF CAMBRIDGE INTERNATIONAL EXAMINATIONS  
General Certificate of Education Ordinary Level

**WOODWORK**

**6030/01**

Paper 1 Theory, Drawing and Design

October/November 2005

**2 hours 45 minutes**

Additional Materials: A2 Drawing Paper (1 sheet)  
Answer Paper  
Coloured crayons  
Metric scale rule, scale 1:5  
Standard drawing equipment

**READ THESE INSTRUCTIONS FIRST**

Write your Centre number, candidate number and name in the spaces at the top of this page and on all the work you hand in.

Write in dark blue or black pen in the spaces provided on the Question Paper.

You may use a soft pencil for any diagrams, graphs or rough working.

Do not use staples, paper clips, highlighters, glue or correction fluid.

**Section I Part A**

Answer **all** parts of Question 1.

Write your answers in the spaces provided on the Question Paper.

**Section I Part B**

Answer any **two** questions.

Write your answers on the separate Answer Paper provided.

**Section II**

Answer **all** parts of this section.

Use the A2 sheet of Drawing Paper prepared prior to the examination for your answers.

At the end of the examination, fasten all your work securely together.

The number of marks is given in brackets [ ] at the end of each question or part question.

All dimensions are in millimetres.

For Examiner's Use	
<b>Section IA</b>	
<b>Section IB</b>	2
	3
	4
	5
<b>Section II</b>	
<b>TOTAL</b>	

If you have been given a label, look at the details. If any details are incorrect or missing, please fill in your correct details in the space given at the top of this page.

Stick your personal label here, if provided.

This document consists of **10** printed pages and **2** blank pages.



**Section I Part A**

Answer **all** questions from this Part in the spaces provided on the Question Paper.

You are advised to spend no longer than 35 minutes on this Part.

- 1 (a) Fig. 1 shows two marks used to identify datum surfaces when preparing wood to size.

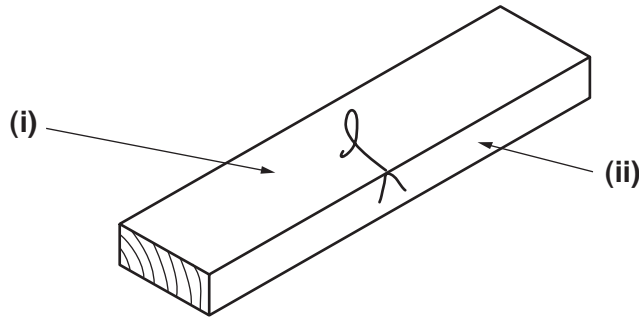

**Fig. 1**

Name the marks.

(i) .....

(ii) .....

[2]

- (b) Name the tools used to prepare these two surfaces.

(i) .....

.....

(ii) .....

.....

[2]

(c) Fig. 2 shows two sets of joints.

3

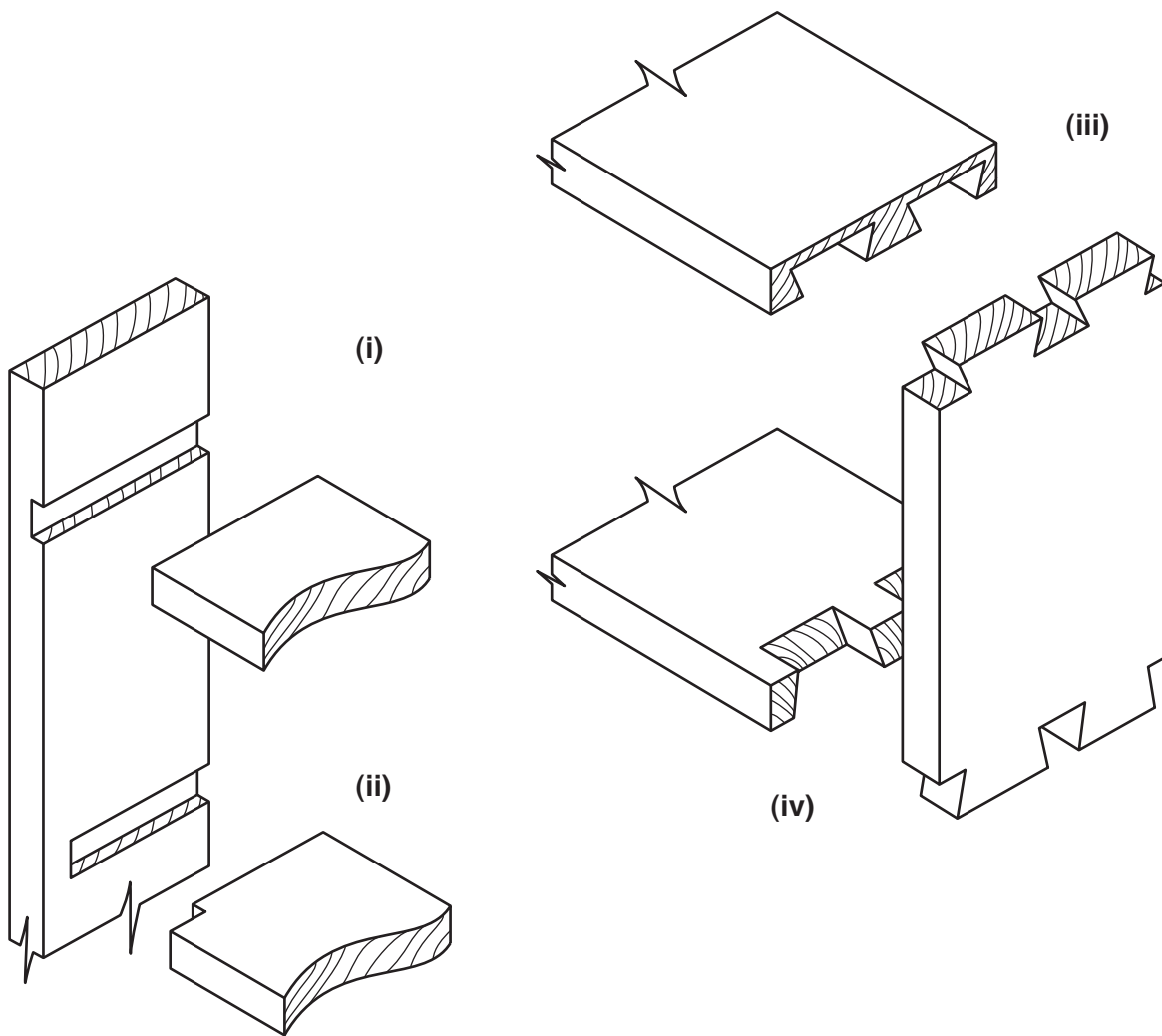

Fig. 2

Name each joint.

(i) .....

(ii) .....

(iii) .....

(iv) .....

[4]

(d) Fig. 3 shows the cross section of a tree trunk and a cut board.

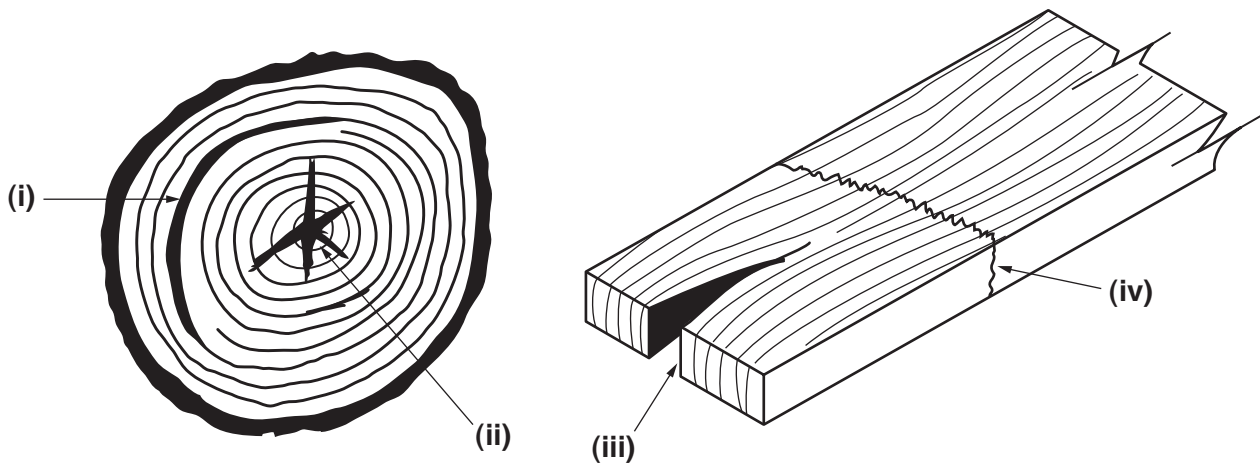

**Fig. 3**

Name each of the defects shown.

- (i) .....
- (ii) .....
- (iii) .....
- (iv) .....

[4]

(e) List two basic personal safety rules which should always be applied when using any tools which have sharp cutting edges.

Rule 1 .....

Rule 2 ..... [2]

(f) Fig. 4 shows a woodworking tool used for marking out.

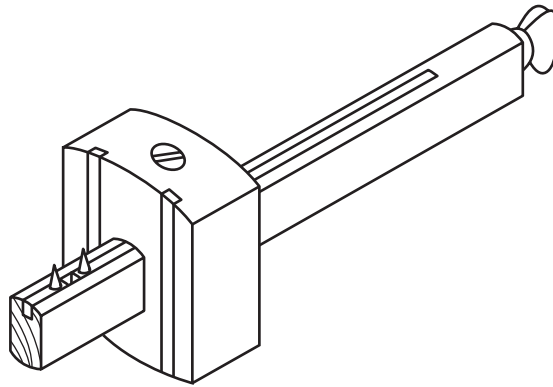

**Fig. 4**

(i) Name the tool shown in Fig. 4 .....

(ii) Give a brief description of the specific use of the tool.

.....  
.....

[2]

(g) Fig. 5 shows the blade of a chisel.

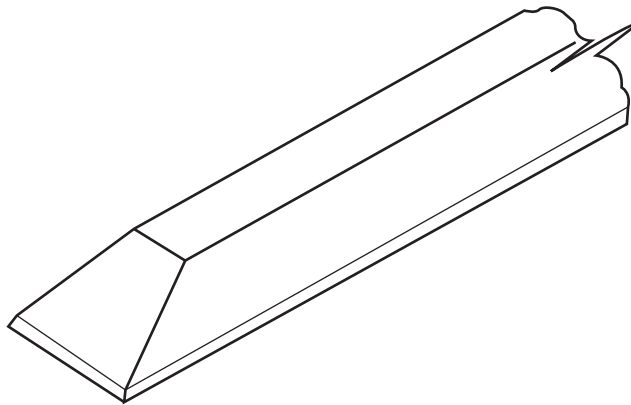

**Fig. 5**

(i) Give the full name of the chisel .....

(ii) Describe a specific use for this tool .....

.....

[2]

**(h)** Fig. 6 shows a joint used in woodwork.

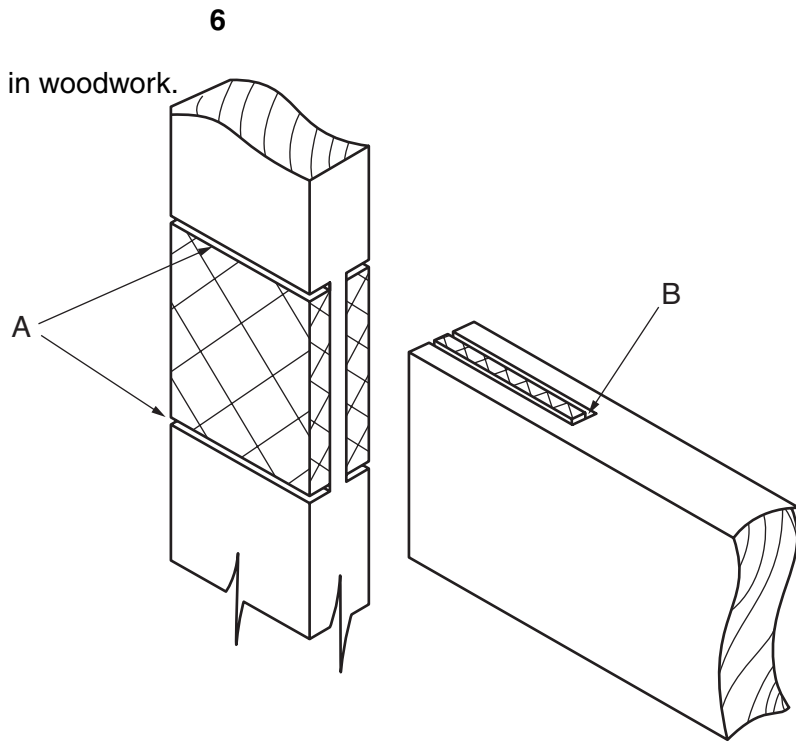

**Fig. 6**

**(i)** Name the joint .....

**(ii)** Name the saw used to cut the lines at:

**A** .....

**B** .....

[3]

**(i)** Name the parts of a smoothing plane shown in Fig. 7.

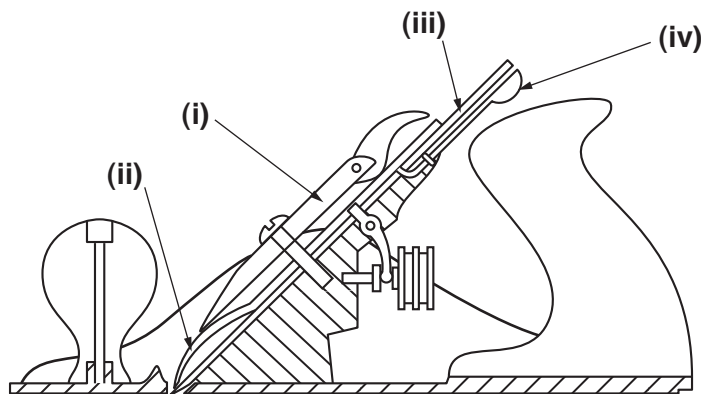

**Fig. 7**

**(i)** .....

**(ii)** .....

**(iii)** .....

**(iv)** .....

[4]

## Section I Part B

Answer any **two** questions from this Part on the separate Answer Paper provided.

You are advised to spend no longer than 35 minutes on this Part.

- 2 (a) Draw sketches to show **two** screws commonly used as fastenings for wood. [4]
- (b) Give a specific use for each of the screws you have shown. [2]
- (c) Use notes and sketches to describe the process involved in preparing two pieces of wood to be joined together using screws. [6]
- Name each tool and process used. [6]

- 3 Fig. 8 shows a solid wooden shelf to be mounted on a wall.

The shelf is to hold a set of books.

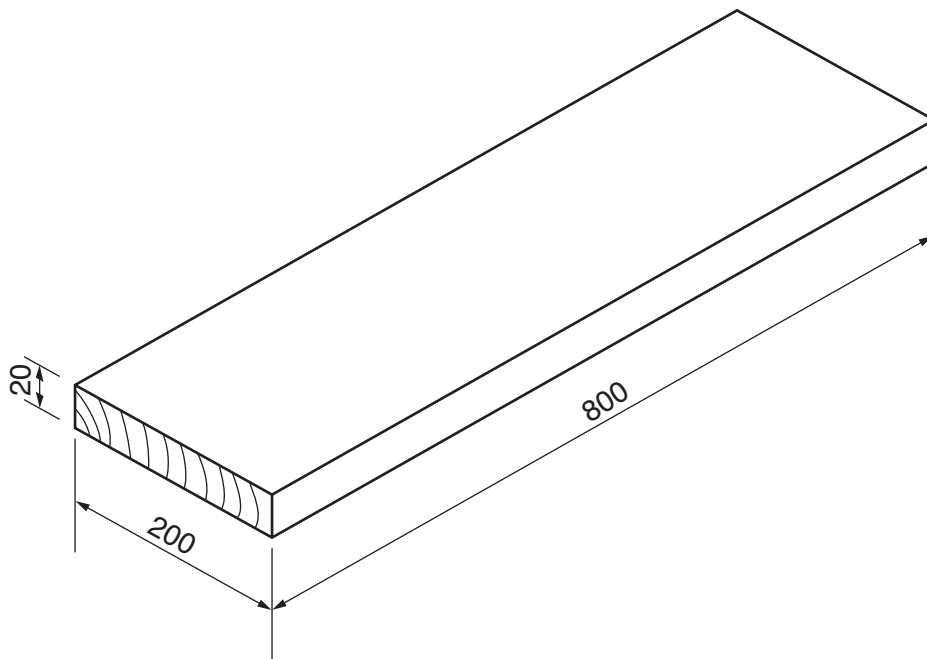

**Fig. 8**

- (a) Use notes and sketches to show methods which could be used to strengthen the shelf:
- (i) along the grain to prevent it sagging with the weight; [4]
- (ii) across the grain so that it remains flat. [4]
- (b) Use notes and sketches to show a method of fixing the shelf to the wall. [4]

4 When timber has been cut into boards it has to be dried out.

(a) Name the process of drying boards. [1]

(b) Name the two main methods of drying timber. [2]

(c) Use notes and sketches to show the main features of **one** of the methods you have named in (b). [6]

(d) In the drying process it is possible to work out the amount of moisture in the timber.

Write down the formula used for this calculation. [3]

5 Fig. 9 shows the corner of a piece of manufactured board.

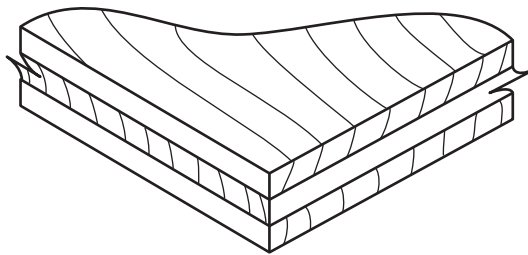

**Fig. 9**

(a) Name the board. [2]

(b) Describe the main advantages of this type of board, when compared to solid wood. [4]

(c) Sketch **three** different types of manufactured board which can be purchased, giving a suitable use for each. [6]



**BLANK PAGE**

**Turn over for Section II**

## Section II Drawing and Design

Answer **all** questions from this Section on the previously prepared Drawing Paper.

Use only **one** side of the Drawing Paper.

You will be required to draw part of this Section to a scale of 1 : 5.

You are advised to spend 1 hour 35 minutes on this Section.

On your Drawing Paper use the space to the right of the vertical line to answer **Part C** of this Section and the space to the left to answer **Part D**.

The drawing on page 11, Fig. 10, shows details of a small side table/magazine holder. The under frame is solid hardwood 45 mm × 20 mm. The table top and magazine holder and drawer carcass are constructed from double faced manufactured board 20 mm thick which is suitably edged. The drawer is of traditional construction. The drawer front is solid hardwood 20 mm thick. The sizes of the drawer parts are left to your discretion.

### Part C

On the right hand part of your Drawing Paper, sketch freehand and approximately full size:

- (i) an exploded view of the joint you would use to join one corner of the underframe at **A**; [8]
- (ii) a design for a handle for the drawer front; [5]
- (iii) shaping to the corners of the top at **B**. [3]

### Part D

(a) Draw in first or third angle projection, using a scale of 1 : 5 (hidden detail is not required):

- (i) a front view in the direction of arrow **Y**; [10]
- (ii) a sectional end view on the line **XX**; [10]
- (iii) a plan. [3]

(b) Add to your drawings **six** main dimensions. [3]

(c) In the Title Box include the following details in suitable lettering:

- (i) a Title;
- (ii) your Name;
- (iii) your Examination Number;
- (iv) the projection you have used. [3]

Marks for Quality [3]

Marks for Layout [2]

11

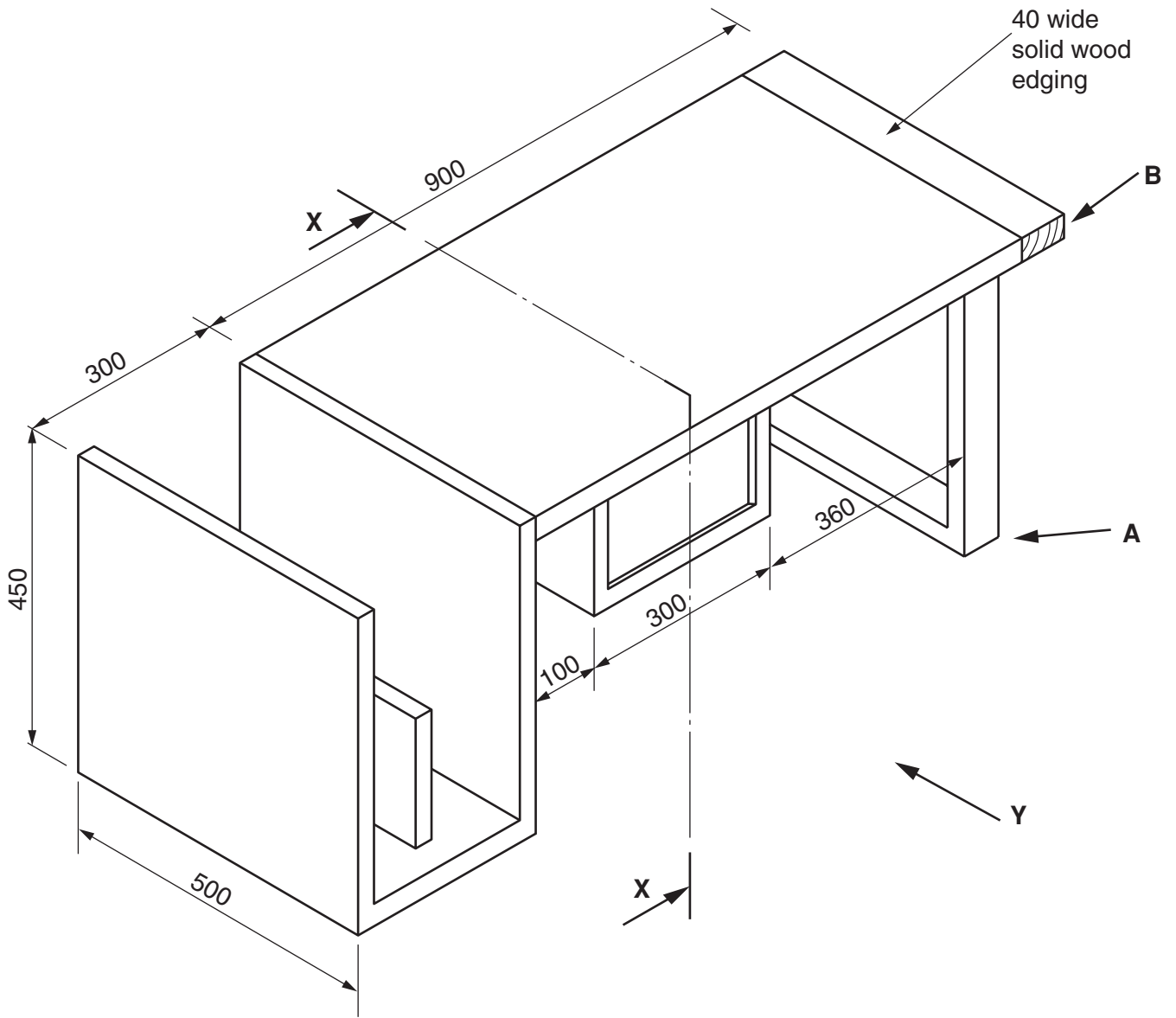

Fig. 10

---

Permission to reproduce items where third-party owned material protected by copyright is included has been sought and cleared where possible. Every reasonable effort has been made by the publisher (UCLES) to trace copyright holders, but if any items requiring clearance have unwittingly been included, the publisher will be pleased to make amends at the earliest possible opportunity.

University of Cambridge International Examinations is part of the University of Cambridge Local Examinations Syndicate (UCLES), which is itself a department of the University of Cambridge.