

**CAMBRIDGE INTERNATIONAL EXAMINATIONS**  
**Joint Examination for the School Certificate**  
**and General Certificate of Education Ordinary Level**

**WOODWORK**

PAPER 1 Theory, Drawing and Design

**6030/1**

**OCTOBER/NOVEMBER SESSION 2002**

2 hours 45 minutes

Additional materials:

A2 Drawing paper (1 sheet)

Answer paper

Coloured crayons

Metric scale rule, scale 1:5

Standard drawing equipment

**TIME** 2 hours 45 minutes

**INSTRUCTIONS TO CANDIDATES**

Write your name, Centre number and candidate number in the spaces at the top of this page and on all separate answer paper used.

**Section I Part A**

Answer **all** parts of Question 1.

Write your answers in the spaces provided on the question paper.

**Section I Part B**

Answer any **two** questions.

Write your answers on the separate answer paper provided.

**Section II**

Answer **all** parts of this section.

Use the A2 sheet of drawing paper prepared prior to the examination for your answers.

At the end of the examination, fasten together the separate answer paper and drawing paper securely to the question paper.

**INFORMATION FOR CANDIDATES**

The number of marks is given in brackets [ ] at the end of each question or part question.

All dimensions are in millimetres.

FOR EXAMINER'S USE	
Section IA	
Section IB	2
	3
	4
	5
Section II	
TOTAL	

**This question paper consists of 10 printed pages and 2 blank page.**

**Section I Part A**

Answer **all** questions from this part in the spaces provided on the question paper.

You are advised to spend no longer than 35 minutes on this part.

1 (a) Name the joints shown in Fig. 1.

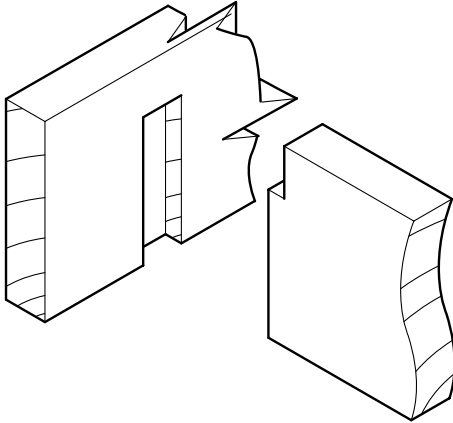

(i) .....

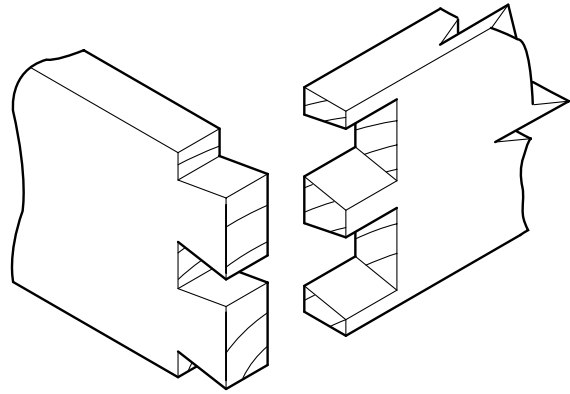

(ii) .....

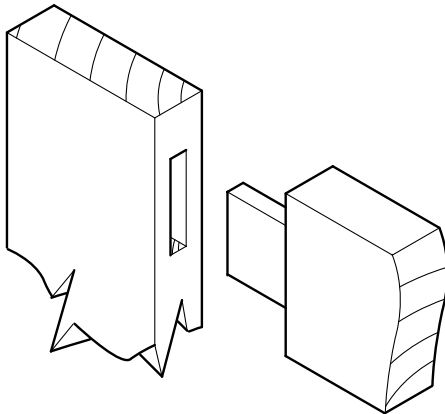

(iii) .....

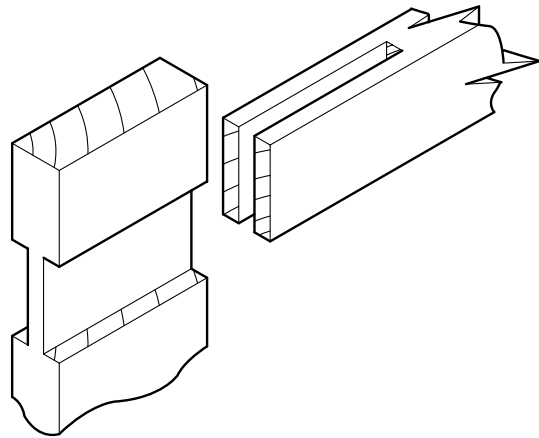

(iv) .....

[4]

**Fig. 1**

(b) Fig. 2 shows two tools. Name both tools and briefly describe the use of each.

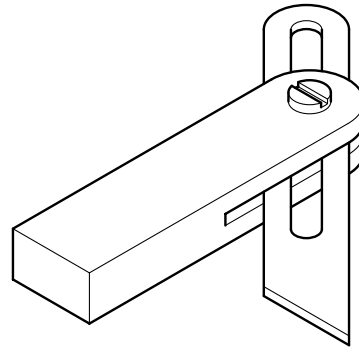
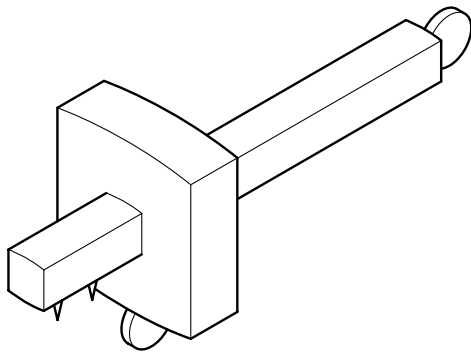

Fig. 2

(i) Name .....

Use.....

.....

(ii) Name .....

Use .....

.....[4]

(c) Give **two** personal safety rules which you must obey when using the following equipment:

(i) a sharp tool such as a chisel.

Rule 1 .....

Rule 2 .....

(ii) a drilling machine.

Rule 1 .....

Rule 2 .....[4]

(d) Fig. 3 shows four fixings used for joining wood together. Name each fixing.

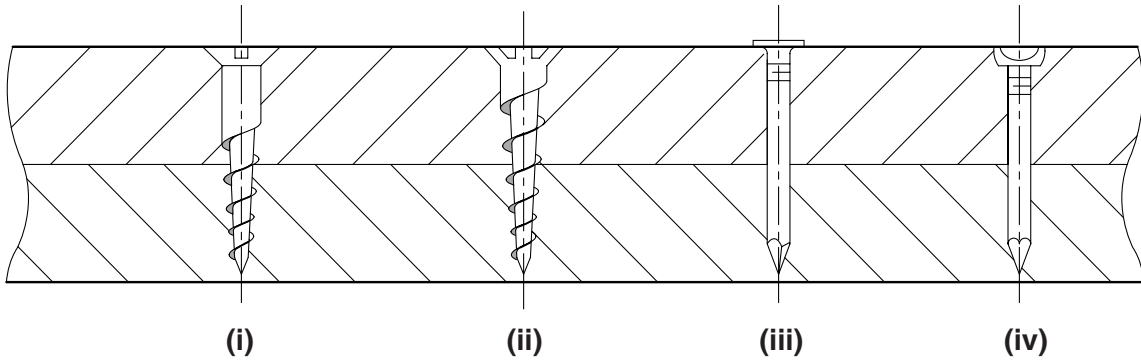

**Fig. 3**

- (i) .....
- (ii) .....
- (iii) .....
- (iv) .....[4]

(e) Three fittings are shown in Fig. 4.

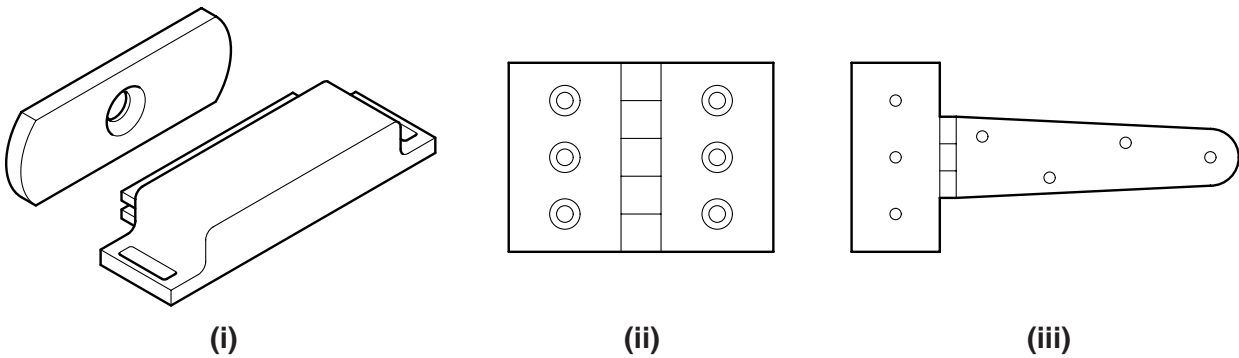

**Fig. 4**

Name and give a specific use for each fitting.

- Fitting (i) Name .....
- Use.....
- Fitting (ii) Name .....
- Use.....
- Fitting (iii) Name .....
- Use.....[6]

(f) The cutting ends of three bits are shown in Fig. 5.

Name each Bit.

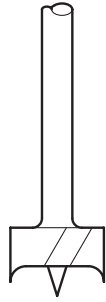

(i)



(ii)



(iii)

Fig. 5

(i) .....

(ii) .....

(iii) ..... [3]

## Section I Part B

Answer any **two** questions from Part B on the separate answer paper provided.

You are advised to spend no longer than 35 minutes on this part.

- 2 Fig. 6 shows a piece of solid wood 10 mm thick, which is to be used as a decorative panel in a door.

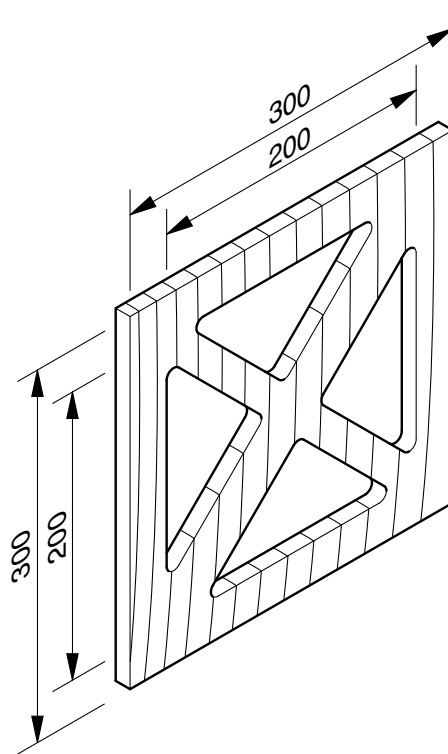

**Fig. 6**

- (a) Explain in detail how you would mark out the shapes of the four identical pieces to be removed from the panel. [4]
- (b) Use notes and sketches to describe how you would remove the waste from one of the interior shapes and finish the edges. Name all of the tools used. [8]

- 3 Fig. 7 shows the cutting edge of a chisel which has been damaged.

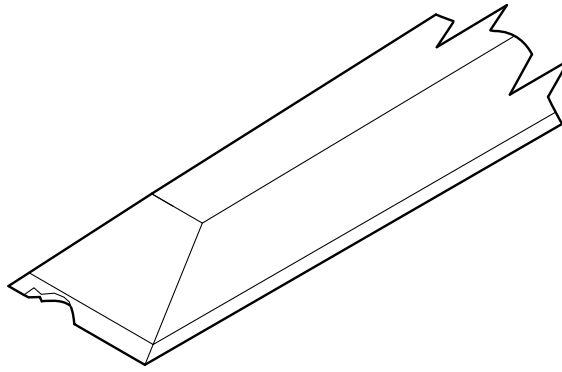

**Fig. 7**

- (a) Give the full name of the chisel. [2]
- (b) Use notes and sketches to describe the two processes involved in repairing the edge of the chisel ready for use. [10]
- 4 From when a tree is cut down, to the time a board is ready to be used in a school workshop, it has to go through several processes.

Use notes and sketches to:

- (a) explain briefly **two** methods of converting a trunk into boards:
- (i) to obtain the maximum number of boards; [2]
  - (ii) to obtain the boards with the best figuring. [2]
- (b) explain the **two** main methods of seasoning boards in preparation for use in the workshop. [8]

5 Fig. 8 shows a joint used in construction.

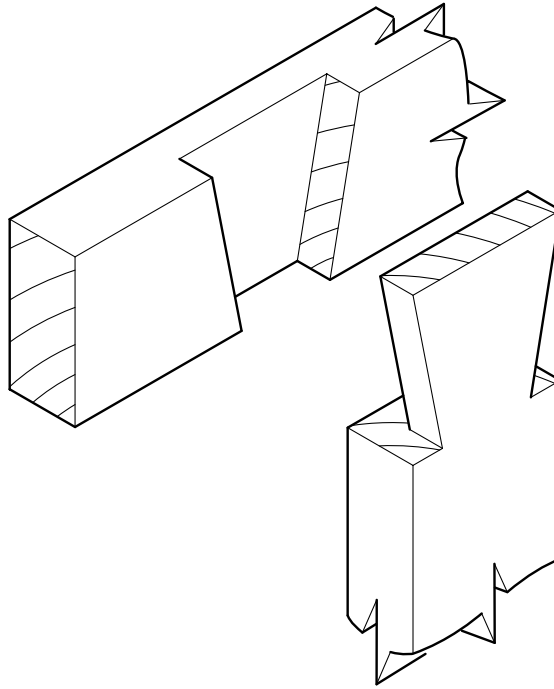

**Fig. 8**

- (a) Name the joint. [2]
- (b) Use notes and sketches to describe the stages of:
- (i) marking out the joint; [4]
  - (ii) cutting both parts of the joint. Name the tools used. [6]



**BLANK PAGE**

**Turn to page 10 for Section II.**

## Section II Drawing and Design

Answer **all** questions on the drawing paper provided.

Use only one side of the previously prepared piece of drawing paper.

You are advised to spend 1 hour 35 minutes on this Section.

Fig. 9, on page 11, shows a desk unit with a side drawer. The top and the carcass are made from faced blockboard, 20 mm thick, which has been edged with hardwood. The base framework is made from hardwood which is 20 mm thick. The drawer is contained within the carcass shown and is of traditional construction.

### Part C.

On the right hand part of your drawing paper:

- (i) sketch freehand the corner of the top of the desk to show the board, edging and facing; [4]
- (ii) sketch freehand a handle for the drawer. The handle can be either fixed to, or cut into the drawer front; [6]
- (iii) sketch approximately half full size an exploded view of the joint you would use to join the foot to the leg at **A**. [6]

### Part D.

On the left hand side of your drawing paper:

- (a) Draw in either first or third angle projection, using a metric scale of 1:5:
  - (i) a front view of the desk in the direction of the arrow **B**; [8]
  - (ii) a sectional end view of the part to the right of the Section line **XX**; [11]
  - (iii) a plan. [4]

Any dimensions not given are left to your discretion.  
Hidden detail is not required.

- (b) Add to your drawings six important dimensions. [3]
- (c) In the title box include, in suitable lettering:
  - (i) a Title;
  - (ii) your Name;
  - (iii) your Examination Number; [2]
  - (iv) the Projection you have used. [1]

Marks for Quality. [3]

Marks for Layout. [2]

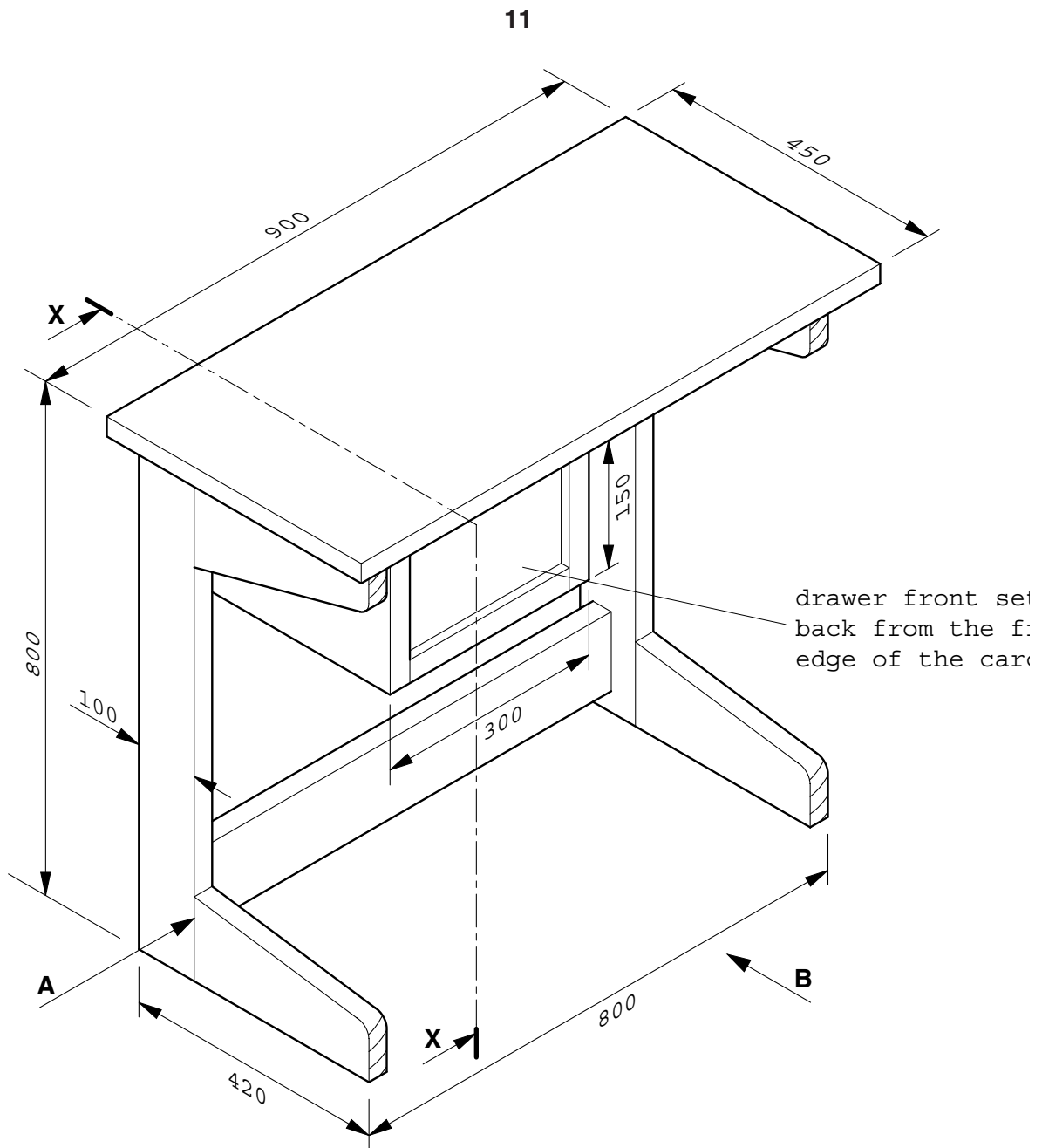

**Fig.9**

