



UNIVERSITY OF CAMBRIDGE INTERNATIONAL EXAMINATIONS
General Certificate of Education Ordinary Level

SCIENCE (PHYSICS, CHEMISTRY)

5124/01

Paper 1 Multiple Choice

October/November 2011

1 hour

Additional Materials: Multiple Choice Answer Sheet
 Soft clean eraser
 Soft pencil (type B or HB is recommended)

READ THESE INSTRUCTIONS FIRST

Write in soft pencil.

Do not use staples, paper clips, highlighters, glue or correction fluid.

Write your name, Centre number and candidate number on the Answer Sheet in the spaces provided unless this has been done for you.

There are **forty** questions on this paper. Answer **all** questions. For each question there are four possible answers **A, B, C** and **D**.

Choose the **one** you consider correct and record your choice in **soft pencil** on the separate Answer Sheet.

Read the instructions on the Answer Sheet very carefully.

Each correct answer will score one mark. A mark will not be deducted for a wrong answer.

Any rough working should be done in this booklet.

A copy of the Periodic Table is printed on page 16.

This document consists of **14** printed pages and **2** blank pages.



- 1 The diagram shows an instrument used in Physics.

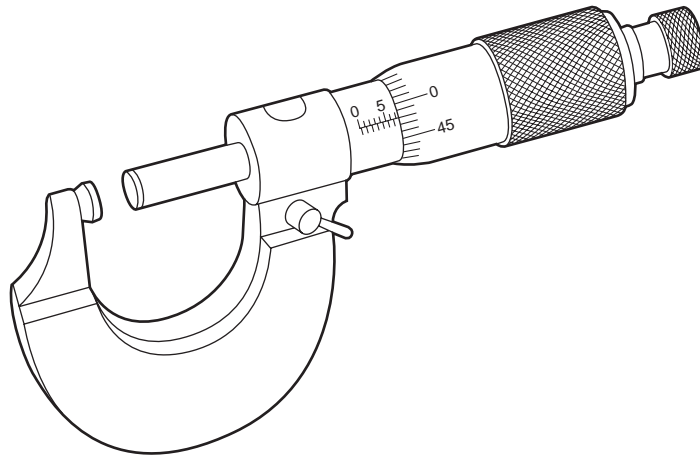

What is the name of this instrument and what is it used to measure?

	name	used to measure
A	calipers	length
B	calipers	pressure
C	micrometer	length
D	micrometer	pressure

- 2 Which car, moving from rest, has an average acceleration of 2.0 m/s^2 ?

- A** a car reaching a speed of 10 m/s in 2 s
- B** a car reaching a speed of 20 m/s in 5 s
- C** a car reaching a speed of 30 m/s in 10 s
- D** a car reaching a speed of 40 m/s in 20 s

- 3 A force is applied to an object on a frictionless surface. It produces an acceleration of 3 m/s^2 .

What are possible values for the applied force and for the mass of the object?

	force / N	mass / kg
A	2	5
B	2	6
C	5	2
D	6	2

- 4 A coin is placed on top of a beaker, as shown.

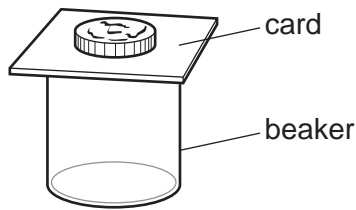

If the card is pulled away quickly, the coin does not move sideways but falls into the beaker.

Which property of the coin makes this possible?

- A density
 - B inertia
 - C thickness
 - D volume
- 5 The diagram shows a lorry.

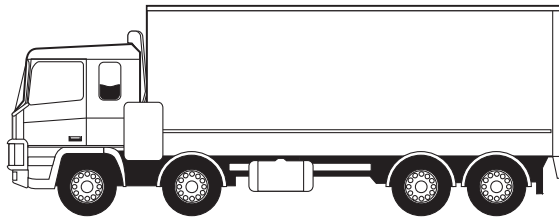

What is the best position for its centre of mass and why is it placed there?

	best position	reason for the position
A	as high as possible	the lorry can accelerate more rapidly
B	as high as possible	the lorry is more stable
C	as low as possible	the lorry can accelerate more rapidly
D	as low as possible	the lorry is more stable

- 6 In an energy transformation sequence, what produces kinetic energy from gravitational potential energy as part of the sequence?
- A burning fuel in a power station
 - B generating hydroelectric energy
 - C generating energy in a nuclear power station
 - D generating energy in a geothermal power station

- 7 A man pushes a heavy box across a floor. He exerts a force of 80 N and the box moves 4.0 m in 5.0 seconds.

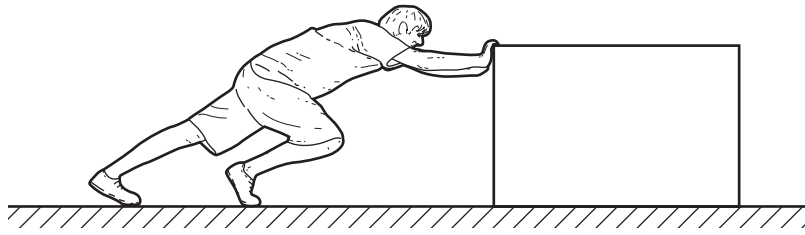

What useful power does the man develop?

- A** 4.0W **B** 64W **C** 100W **D** 1600W
- 8 Which property is essential to a clinical thermometer?
- A** It contains mercury.
B It has a constriction in its bore.
C It has a range of 40 °C.
D It is accurate to 0.001 °C.
- 9 At regular intervals along a railway line there is a gap between the rail sections.

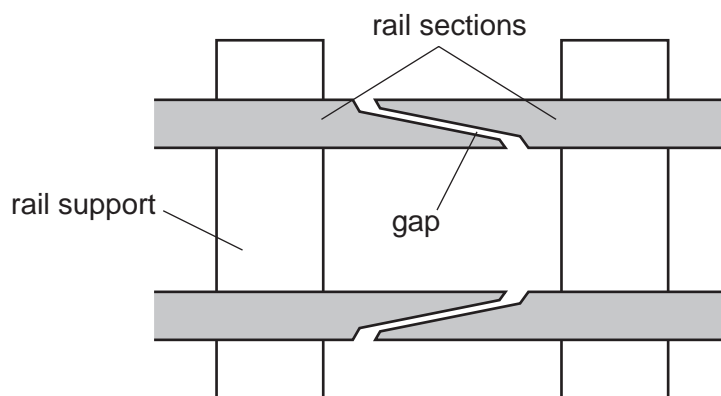

What is the reason for the gap between the rail sections?

- A** to allow for expansion of the rail sections during hot weather
B to allow for vibrations of the rail sections as the train passes over them
C to allow rain water to drain from the rail sections
D to keep the wheels of the train and carriages on the rail sections
- 10 A VHF radio station broadcasts at a frequency of 60 MHz (6.0×10^7 Hz). The speed of radio waves is 3.0×10^8 m/s.

What is the wavelength of the waves broadcast by the station?

- A** 5.0m **B** 2.0m **C** 0.5m **D** 0.2m

11 The diagram shows the reflection of a ray of light from an object in a plane mirror.

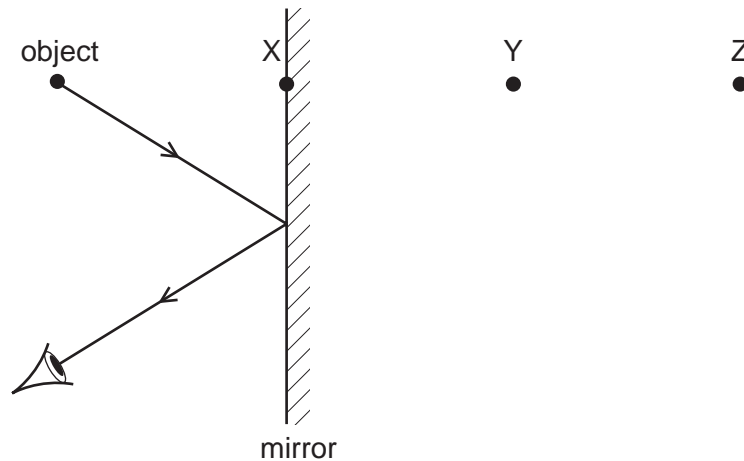

Which statement is correct?

- A The image is at X.
- B The image is between X and Y.
- C The image is at Y.
- D The image is between Y and Z.

12 The diagram shows an object O placed 3 cm away from a converging lens of focal length 6 cm.

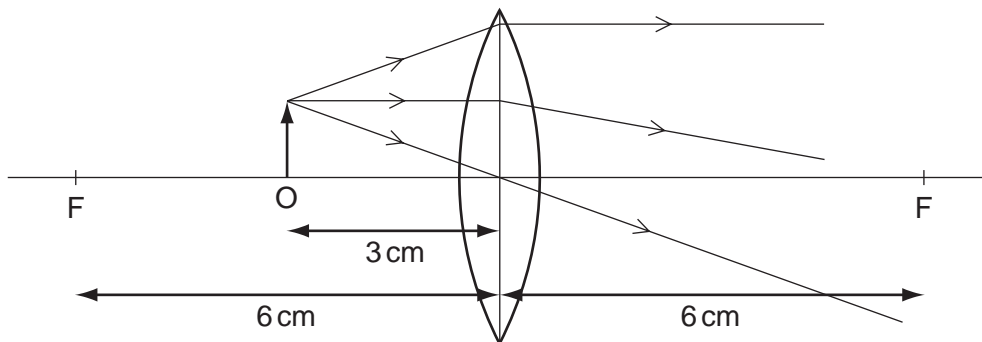

What type of image is produced?

- A real, upright and diminished
- B real, inverted and magnified
- C virtual, upright and magnified
- D virtual, inverted and diminished

13 What is an approximate value of the speed of sound in air under normal atmospheric conditions?

- A 3×10^8 cm/s
- B 3×10^6 cm/s
- C 3×10^4 cm/s
- D 3×10^2 cm/s

14 Which diagram correctly shows the directions of the electrostatic forces on a pair of charged spheres?

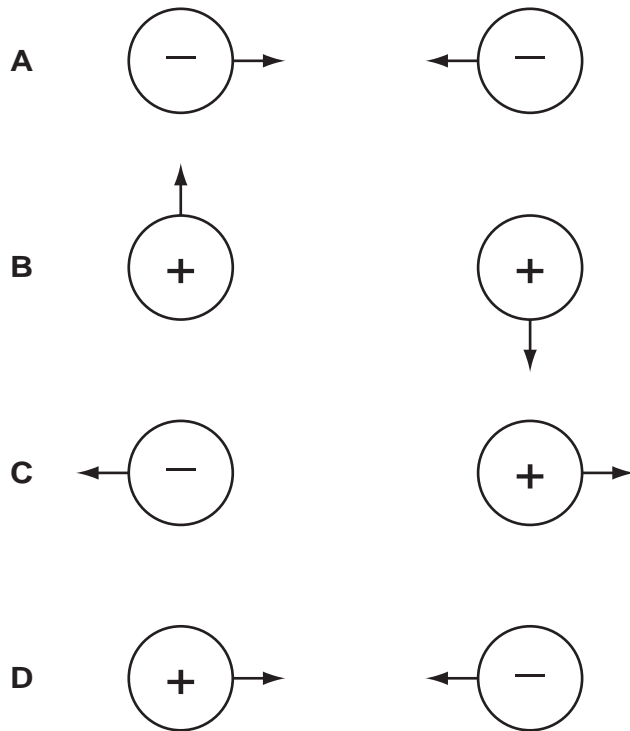

15 A conductor carries a current of 2.0 A.

How long does it take for 10 C of charge to pass one point in the conductor?

- A 0.20 s
- B 5.0 s
- C 12 s
- D 20 s

16 A constant-voltage source is connected to a resistor which has a current I through it.

Two more identical resistors are then added in series with the first.

What is the current now?

- A $\frac{I}{4}$
- B $\frac{I}{3}$
- C I
- D $3I$

17 The diagram shows an unsafe use of an extension cable.

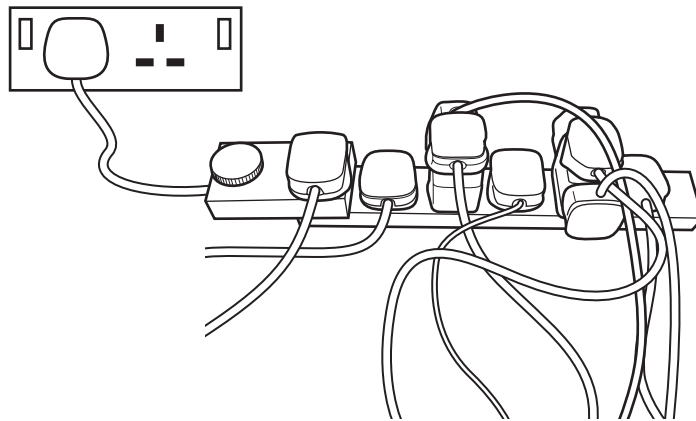

What is the electrical hazard?

- A the danger of burning out the appliances
- B the danger of melting the fuse
- C the danger of overheating the cable
- D the danger of the appliances not being earthed

18 The transformer in the diagram has an input coil with N_i turns and an output coil with N_o turns.

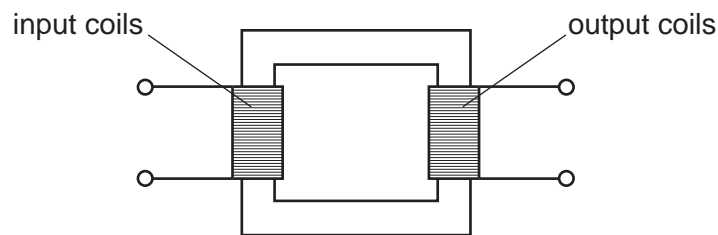

The output voltage needs to be lower than the input voltage.

What is needed for the transformer to work correctly?

	input supply	relative values of N_i and N_o
A	a.c.	$N_i > N_o$
B	a.c.	$N_i < N_o$
C	d.c.	$N_i > N_o$
D	d.c.	$N_i < N_o$

19 What is the relationship between the number of electrons, neutrons and protons in a neutral atom of $^{14}_6\text{C}$? (n = number of neutrons, p = number of protons, e = number of electrons)

- A $n > p, p = e$
- B $n = p, p > e$
- C $n = p, p < e$
- D $n < p, p = e$

20 When a radioactive nucleus decays by alpha-particle emission, it loses

- A 1 proton and 1 electron.
- B 1 proton only.
- C 2 protons and 2 electrons.
- D 2 protons and 2 neutrons.

21 Which piece of apparatus would be most suitable to measure accurately the volume of acid needed to neutralise 25.0 cm^3 of an alkali?

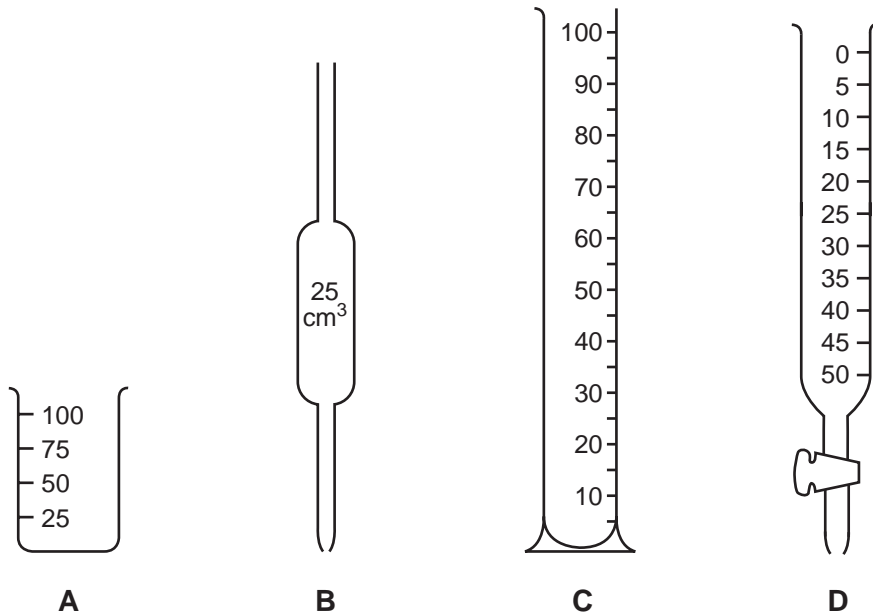

22 In which conversion do water molecules lose speed?

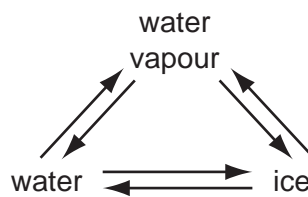

- A ice \rightarrow water
- B ice \rightarrow water vapour
- C water vapour \rightarrow ice
- D water \rightarrow water vapour

23 An atom of element X is represented by ${}^7_3\text{X}$.

Which statement about this atom of X is correct?

- A It is in Group III of the Periodic Table.
- B It is in Group VII of the Periodic Table.
- C The total number of protons and electrons is 6.
- D The total number of protons and neutrons is 10.

24 How does a magnesium atom form a bond with an oxygen atom?

- A by giving two electrons to the oxygen atom
- B by sharing one pair of electrons
- C by sharing two pairs of electrons
- D by taking two electrons from the oxygen atom

25 The table shows the electronic structures of four elements.

element	electronic structure
W	2, 6
X	2, 8
Y	2, 8, 1
Z	2, 8, 7

Which pair of atoms form a covalent molecule?

- A two atoms of W
- B two atoms of X
- C an atom of W and an atom of X
- D an atom of Y and an atom of Z

26 A substance contains the ions X^{4+} and Y^{2-} .

What is the simplest formula of the compound containing the ions X^{4+} and Y^{2-} ?

- A XY_2
- B X_2Y
- C X_2Y_4
- D X_4Y_2

27 Which process is endothermic?

- A the formation of a hydrogen-chlorine bond
- B the formation of silver from silver salts in photography
- C the formation of water from oxygen and hydrogen
- D the formation of water from steam

28 The rate of the reaction between a given mass of calcium carbonate and an excess of hydrochloric acid is studied by collecting the carbon dioxide in a graduated syringe.

The results are shown in the graph.

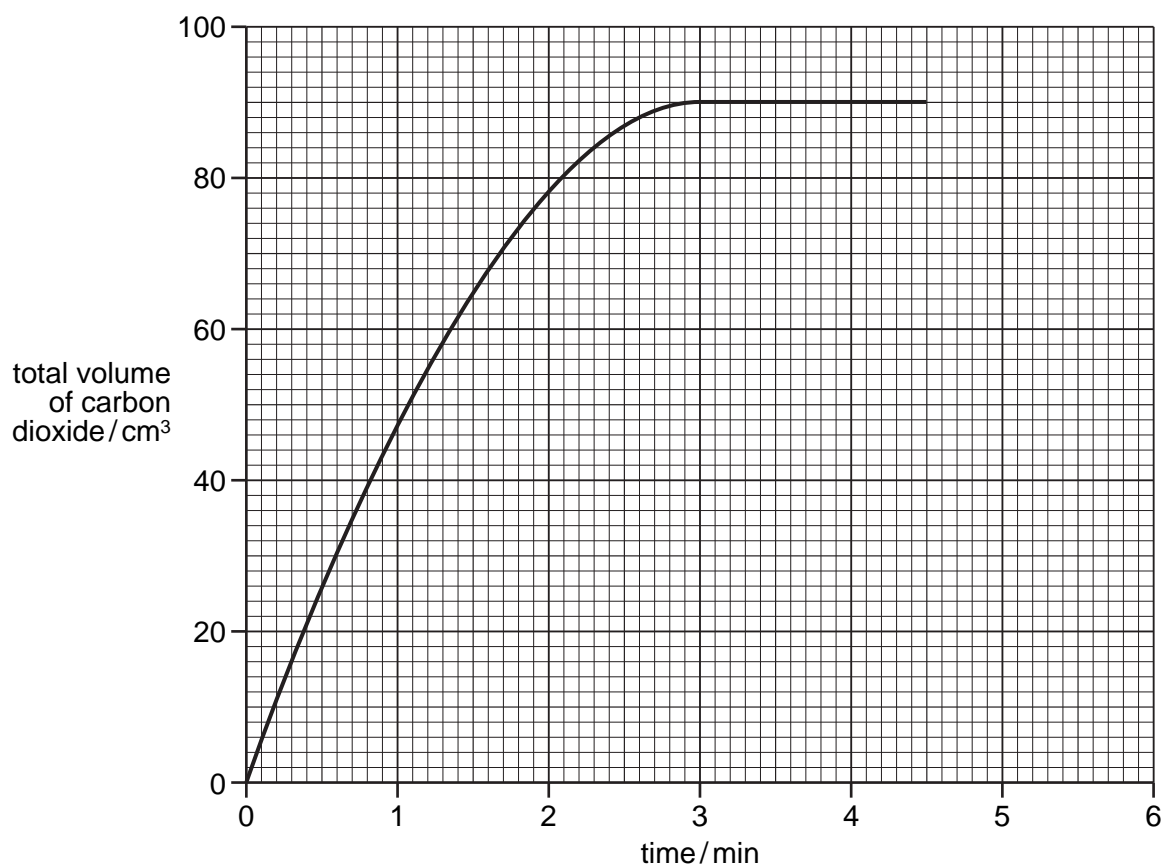

How much time is required for half the calcium carbonate to react?

- A 0.95 min
- B 1.5 min
- C 2.0 min
- D 3.0 min

29 Which statement about all acids is correct?

- A They contain both hydrogen and oxygen.
- B They give ammonia with an ammonium salt.
- C They have a pH value below 7.
- D They react with all metals to form hydrogen.

30 What are the properties of bromine?

	state at room temperature	result of adding bromine to aqueous potassium iodide
A	gas	no reaction
B	gas	reaction
C	liquid	no reaction
D	liquid	reaction

31 Which diagram represents the structure of an alloy?

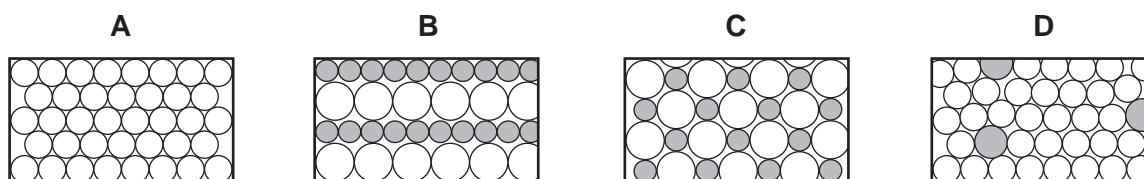

32 Water is formed when hydrogen is passed over the heated oxide of metal X.

No water is formed when hydrogen is passed over the heated oxide of metal Y.

What is the order of reactivity of hydrogen, metal X and metal Y?

	most reactive	—————▶	least reactive
A	hydrogen	X	Y
B	X	hydrogen	Y
C	X	Y	hydrogen
D	Y	hydrogen	X

33 Aluminium is used to make saucepans because of its apparent lack of reactivity.

Which property of aluminium explains its unreactivity?

- A** It has a high electrical conductivity.
- B** It has a layer of oxide on its surface.
- C** It has a low density.
- D** It is in Group III of the Periodic Table.

34 Ammonia may be obtained from ammonium chloride by heating with

- A aqueous calcium chloride.
- B aqueous sodium hydroxide.
- C dilute hydrochloric acid.
- D water.

35 The table shows the boiling point ranges of fractions collected from distillation of a sample of petroleum (crude oil).

Which fraction contains the smallest molecules?

fraction	boiling point range
A	20 – 50°C
B	50 – 100°C
C	100 – 150°C
D	150 – 250°C

36 Which is the molecular formula of an alkane?

- A** C₃H₆ **B** C₄H₁₀ **C** C₆H₁₂ **D** C₇H₁₈

37 The equation shows a molecule of hexane being cracked into two smaller molecules by heating to a high temperature.

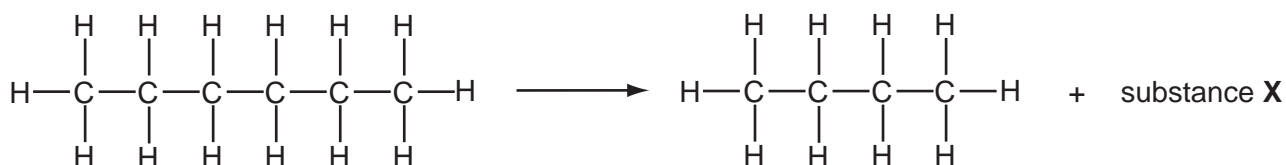

What is the structure of substance **X**?

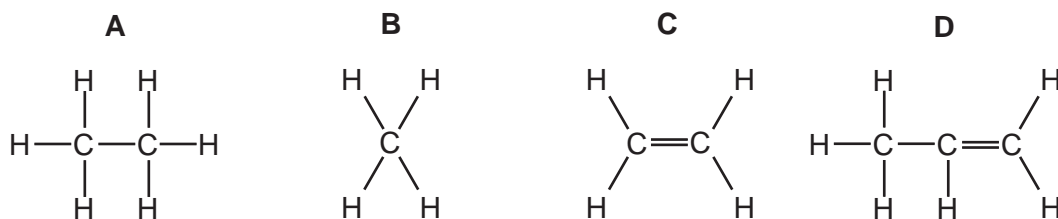

38 Which substance turns aqueous bromine from brown to colourless?

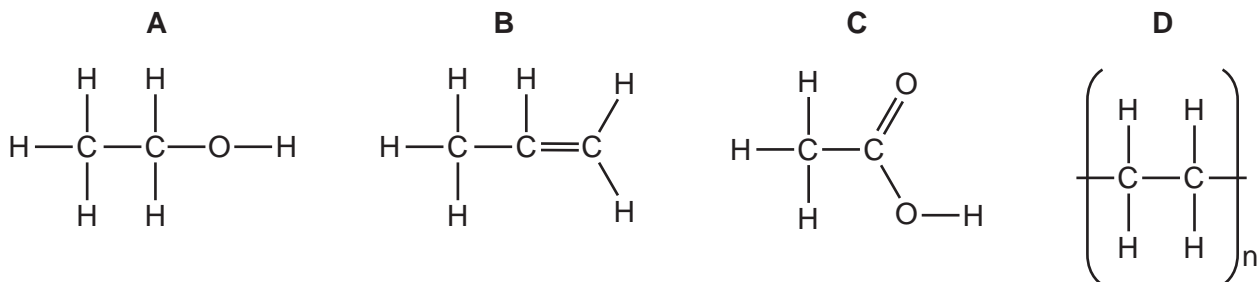

39 Which substance can be oxidised to form ethanoic acid?

- A** CH₃OH **B** C₂H₅OH **C** C₃H₇OH **D** C₄H₉OH

40 What is formed when proteins are hydrolysed?

- A** alcohols
B amino acids
C esters
D fats

DATA SHEET
The Periodic Table of the Elements

		Group																																																																			
I	II	III	IV	V	VI	VII	O																																																														
7 Li Lithium 3	9 Be Beryllium 4	1 H Hydrogen 1	11 B Boron 5	12 C Carbon 6	14 N Nitrogen 7	16 O Oxygen 8	19 F Fluorine 9	20 Ne Neon 10	23 Na Sodium 11	24 Mg Magnesium 12	27 Al Aluminium 13	28 Si Silicon 14	31 P Phosphorus 15	32 S Sulfur 16	35.5 Cl Chlorine 17	40 Ar Argon 18	39 K Potassium 19	40 Ca Calcium 20	45 Sc Scandium 21	48 Ti Titanium 22	51 V Vanadium 23	52 Cr Chromium 24	55 Mn Manganese 25	56 Fe Iron 26	59 Co Cobalt 27	59 Ni Nickel 28	64 Cu Copper 29	65 Zn Zinc 30	70 Ga Gallium 31	73 Ge Germanium 32	75 As Arsenic 33	79 Se Selenium 34	80 Br Bromine 35	84 Kr Krypton 36	85 Rb Rubidium 37	88 Sr Strontium 38	89 Y Yttrium 39	91 Zr Zirconium 40	93 Nb Niobium 41	96 Mo Molybdenum 42	101 Ru Ruthenium 44	103 Rh Rhodium 45	106 Pd Palladium 46	112 Cd Cadmium 48	115 In Indium 49	119 Sn Tin 50	122 Sb Antimony 51	127 I Iodine 53	131 Xe Xenon 54	133 Cs Caesium 55	137 Ba Barium 56	139 La Lanthanum 57	178 Hf Hafnium 72	181 Ta Tantalum 73	184 W Tungsten 74	190 Os Osmium 76	192 Ir Iridium 77	195 Pt Platinum 78	197 Au Gold 79	201 Hg Mercury 80	204 Tl Thallium 81	207 Pb Lead 82	209 Bi Bismuth 83	210 Po Polonium 84	210 At Astatine 85	210 Rn Radon 86	226 Ra Radium 88	227 Ac Actinium 89	†
												140 Ce Cerium 58	141 Pr Praseodymium 59	144 Nd Neodymium 60	150 Sm Samarium 62	152 Eu Europium 63	157 Gd Gadolinium 64	159 Tb Terbium 65	162 Dy Dysprosium 66	165 Ho Holmium 67	167 Er Erbium 68	169 Tm Thulium 69	173 Yb Ytterbium 70	175 Lu Lutetium 71	232 Th Thorium 90	238 U Uranium 92	238 Pa Protactinium 91	238 Np Neptunium 93	238 Pu Plutonium 94	238 Am Americium 95	238 Cm Curium 96	238 Bk Berkelium 97	238 Cf Californium 98	238 Es Einsteinium 99	238 Fm Fermium 100	238 Md Mendelevium 101	238 No Nobelium 102	238 Lr Lawrencium 103																															

*58-71 Lanthanoid series
†90-103 Actinoid series

a	X	a = relative atomic mass
b	X	b = proton (atomic) number

Key

The volume of one mole of any gas is 24 dm³ at room temperature and pressure (r.t.p.).

Permission to reproduce items where third-party owned material protected by copyright is included has been sought and cleared where possible. Every reasonable effort has been made by the publisher (UCLES) to trace copyright holders, but if any items requiring clearance have unwittingly been included, the publisher will be pleased to make amends at the earliest possible opportunity.

University of Cambridge International Examinations is part of the Cambridge Assessment Group. Cambridge Assessment is the brand name of University of Cambridge Local Examinations Syndicate (UCLES), which is itself a department of the University of Cambridge.