

UNIVERSITY OF CAMBRIDGE INTERNATIONAL EXAMINATIONS  
General Certificate of Education Ordinary Level

**SCIENCE (PHYSICS, CHEMISTRY)**

**5124/01**

Paper 1 Multiple Choice

October/November 2004

**1 hour**

Additional Materials: Multiple Choice Answer Sheet  
Soft clean eraser  
Soft pencil (type B or HB is recommended)

**READ THESE INSTRUCTIONS FIRST**

Write in soft pencil.

Do not use staples, paper clips, highlighters, glue or correction fluid.

Write your name, Centre number and candidate number on the answer sheet in the spaces provided unless this has been done for you.

There are **forty** questions on this paper. Answer **all** questions. For each question there are four possible answers **A, B, C**, and **D**.

Choose the **one** you consider correct and record your choice in **soft pencil** on the separate answer sheet.

**Read the instructions on the Answer Sheet very carefully.**

Each correct answer will score one mark. A mark will not be deducted for a wrong answer.

Any rough working should be done in this booklet.

A copy of the Periodic Table is included on page 16.

This document consists of **16** printed pages.



- 1 The graph shows part of a car journey.

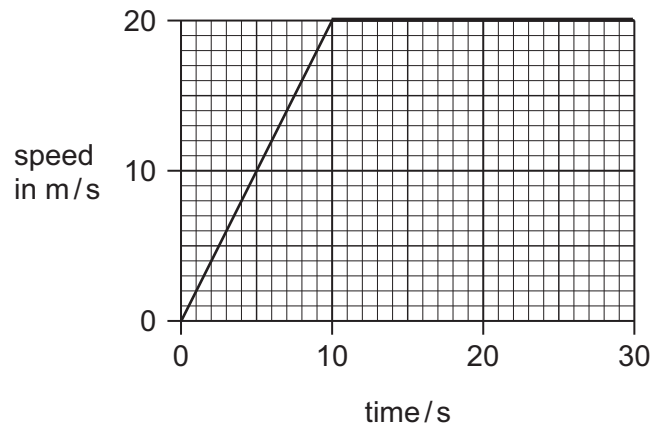

What distance is travelled by the car in the first 20 s?

- A** 100 m      **B** 200 m      **C** 300 m      **D** 400 m
- 2 The table shows the weights of some masses on the surface of four different planets.

Which planet has the greatest gravitational field strength?

	mass	weight
<b>A</b>	0.5 kg	20 N
<b>B</b>	2.0 kg	20 N
<b>C</b>	0.5 kg	40 N
<b>D</b>	2.0 kg	40 N

- 3 The diagrams show the same spring with different weights attached.

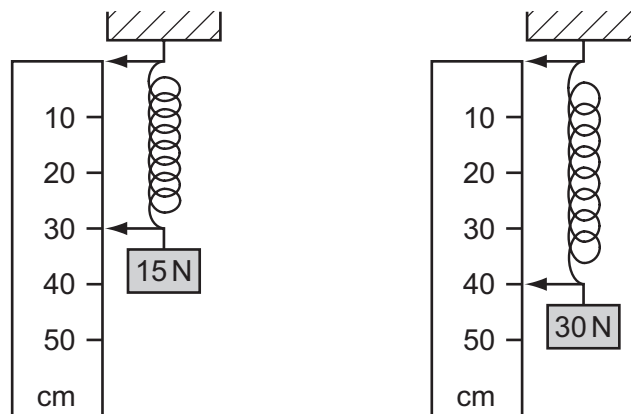

When the weights are removed, the spring returns to its original length.

What is the original length of the spring?

- A** 25 cm      **B** 20 cm      **C** 15 cm      **D** 10 cm

4 Brakes are used to stop a car.

What is most of the kinetic energy converted into?

- A heat energy
- B light energy
- C potential energy
- D sound energy

5 In a hydroelectric power station, water flows from a high reservoir to turn turbines to generate electricity.

Which energy conversions take place?

- A gravitational potential → chemical / fuel → electrical
- B gravitational potential → kinetic → electrical
- C kinetic → chemical / fuel → electrical
- D kinetic → gravitational potential → electrical

6 Where and at which temperature does evaporation of a liquid occur?

	where	temperature
A	point(s) of heating	a fixed point
B	point(s) of heating	any
C	surface	a fixed point
D	surface	any

- 7 The diagram shows ice cubes being used to lower the temperature of a drink.

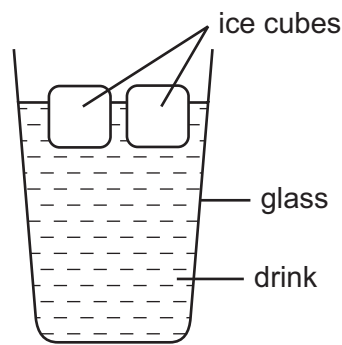

What is the **main** process by which the liquid at the bottom of the glass cools?

- A conduction
  - B convection
  - C radiation
  - D a combination of radiation and conduction
- 8 The diagram shows a dipper producing circular waves in a ripple tank.

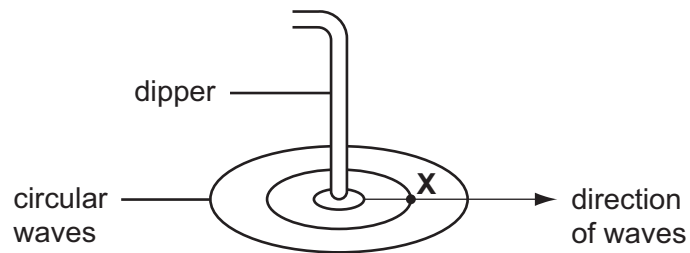

Which wave property describes the number of waves passing point **X** per second?

- A wavelength
  - B speed
  - C frequency
  - D amplitude
- 9 Which statement about the image formed by a thin converging lens is correct?
- A It is always real and erect.
  - B It is always real and inverted.
  - C It is always virtual and erect.
  - D It may be either virtual or real.

10 What is a property of all electromagnetic waves?

- A They are deflected by magnets.
- B They are positively charged.
- C They travel at the speed of sound.
- D They travel through a vacuum.

11 What is the correct order for the speed of sound in air, steel and water?

	slowest	—————>	fastest
<b>A</b>	air	steel	water
<b>B</b>	air	water	steel
<b>C</b>	water	air	steel
<b>D</b>	water	steel	air

12 The diagram shows a locking device.

When the current is switched off, the spring pulls the bar to the right.

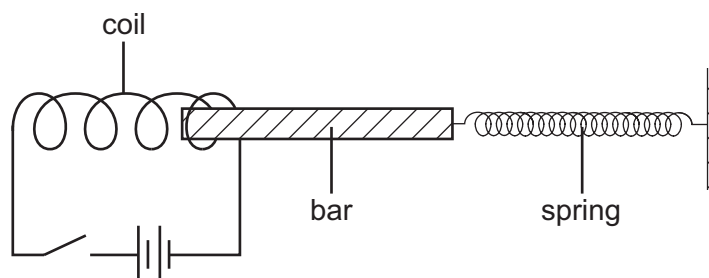

Which materials should the coil and the bar be made from?

	coil	bar
<b>A</b>	copper	iron
<b>B</b>	copper	copper
<b>C</b>	iron	copper
<b>D</b>	steel	nylon

13 Which circuit can be used to find the resistance of the lamp?

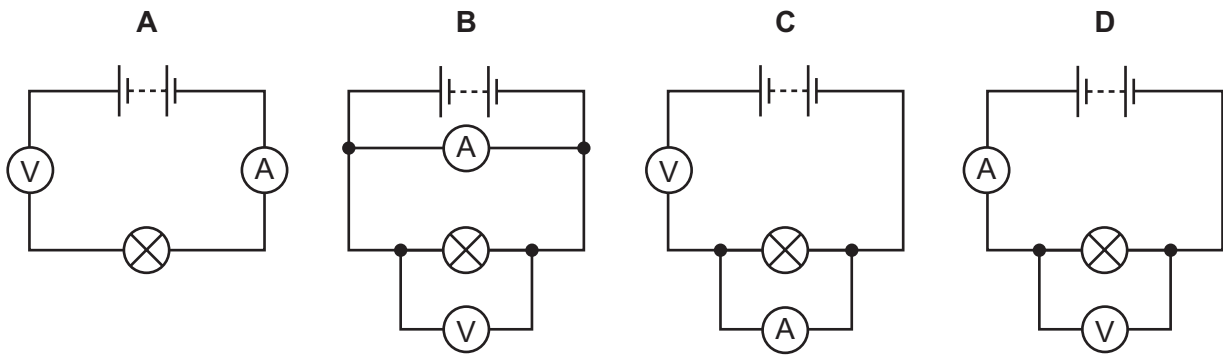

14 An electric lamp uses energy at the rate of 48 W with a 12 V supply.

How much charge passes through the lamp in 2.0 seconds?

- A** 0.25 C      **B** 0.50 C      **C** 2.0 C      **D** 8.0 C

15 In the circuit shown, the brightness of the lamp can be altered by changing the resistance of the variable resistor, R.

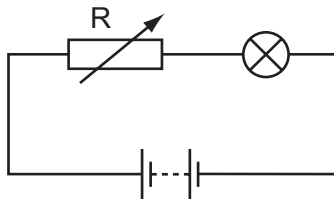

This is because varying the resistance changes

- A** the current flowing in the circuit.  
**B** the electromotive force (e.m.f) of the battery.  
**C** the resistance of the bulb.  
**D** the temperature of the battery.

- 16 A plug is wrongly wired as shown. It is connected to an old vacuum cleaner which has a metal case.

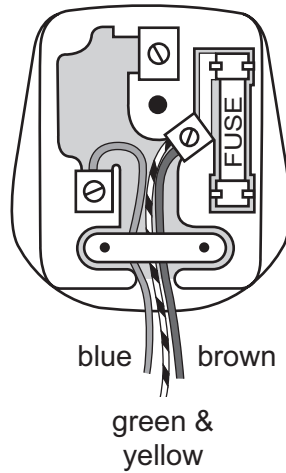

What would be the effect of using the plug wired in this way?

- A The fuse in the plug would blow.
  - B The metal case would be live.
  - C The neutral wire would melt.
  - D The vacuum cleaner would catch fire.
- 17 A heater used on a 250V mains circuit has a 5A fuse in its plug.

Which is the highest power rating for this heater?

- A 50W
  - B 250W
  - C 1000W
  - D 2000W
- 18 The diagram shows the north pole of a magnet moved into, and out of, a coil of wire.

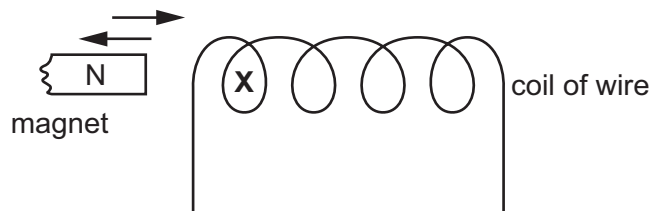

What describes the poles produced in the coil at X by the movement of the magnet?

	north pole in	north pole out
<b>A</b>	N	N
<b>B</b>	N	S
<b>C</b>	S	N
<b>D</b>	S	S

- 19 The table shows how the activity of a radioactive substance changes over a period of time. (Allowance has been made for the background radiation.)

time / minutes	0	5	10	15	20	25	30	35	40
activity / counts per second	114	102	90	83	73	65	57	51	45

What is the half-life of the substance?

- A 73 minutes  
 B 57 minutes  
 C 30 minutes  
 D 20 minutes
- 20 What particles are present in the nucleus of the oxygen nuclide  $^{17}_8\text{O}$ ?

	neutrons	protons
A	9	8
B	17	8
C	8	9
D	9	17

- 21 Which statement about the molecules in carbon dioxide gas is correct?
- A The molecules are close together.  
 B The molecules are diatomic.  
 C The molecules are in fixed positions.  
 D The molecules move randomly.



- 22 Which piece of apparatus would be most suitable to measure accurately the volume of acid needed to neutralise  $25.0 \text{ cm}^3$  of an alkali?

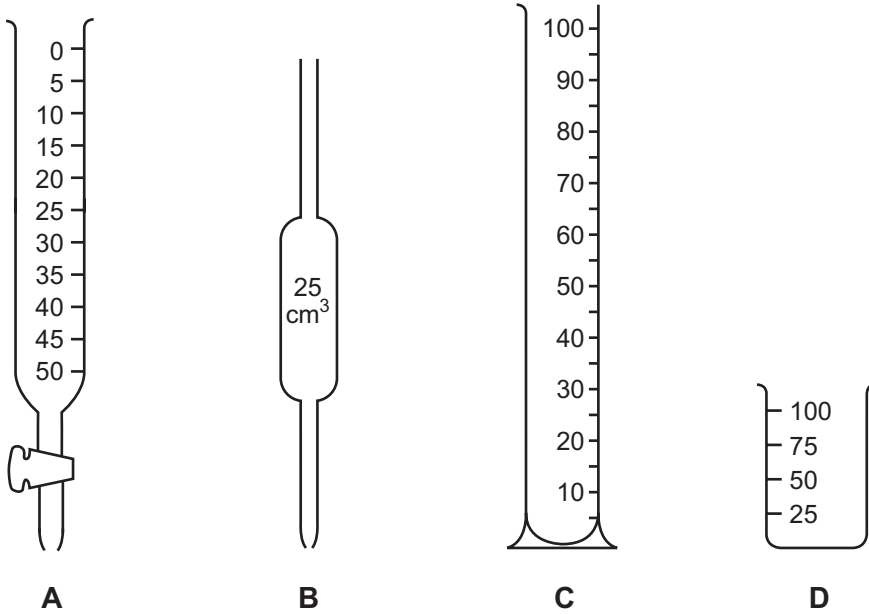

- 23 Which diagram shows the structure of a  ${}^7_3\text{Li}$  atom?

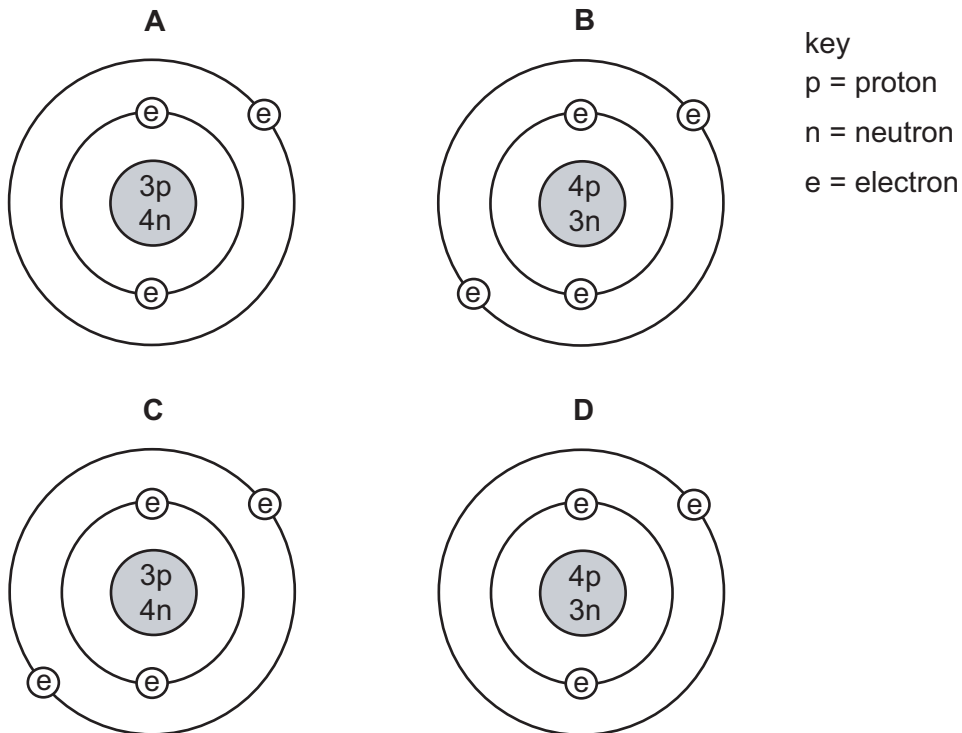

24 Which statement describes the formation of a chloride ion from a chlorine atom?

- A The atom gains one electron.
- B The atom gains two electrons.
- C The atom loses one electron.
- D The atom loses two electrons.

25 Which mass of oxygen combines with 12 g of magnesium?

- A 4 g
- B 8 g
- C 16 g
- D 32 g

26 Which volume of sulphur dioxide (at r.t.p.) is formed when 9.7 g of zinc sulphide is heated in air?

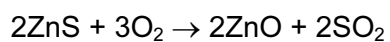

- A 1.2 dm<sup>3</sup>      B 2.4 dm<sup>3</sup>      C 3.6 dm<sup>3</sup>      D 4.8 dm<sup>3</sup>

27 Two experiments were carried out using the apparatus as shown.

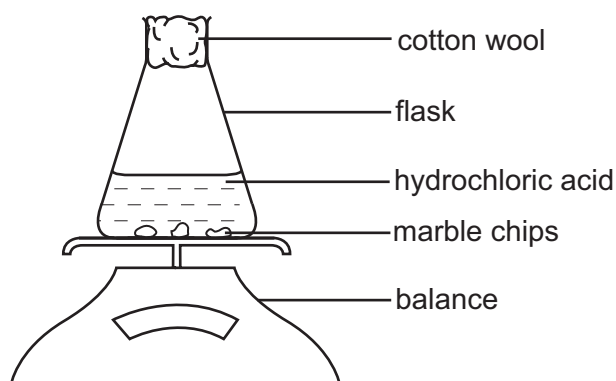

In experiment 1, dilute hydrochloric acid was used.

In experiment 2, concentrated hydrochloric acid was used.

All other conditions were the same and in both experiments all the marble chips had completely reacted.

Which diagram shows the results obtained?

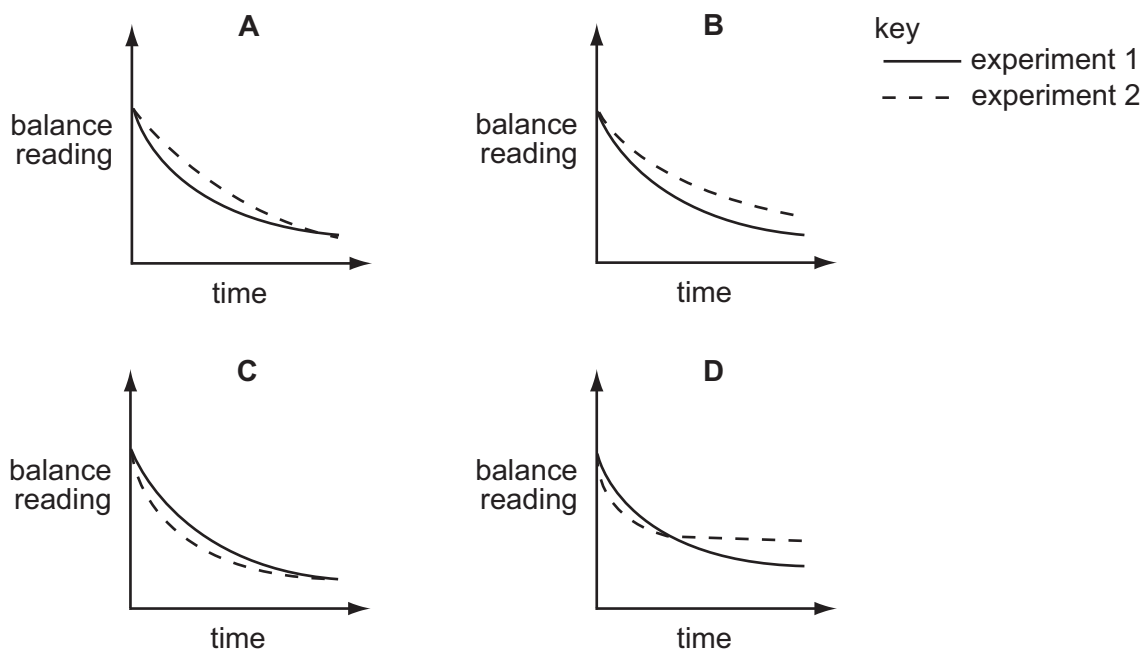

28 Which salt can be prepared by the reaction between a soluble metal hydroxide and dilute sulphuric acid?

- A copper(II) sulphate
- B iron(II) sulphate
- C lead(II) sulphate
- D potassium sulphate

29 Many crops will not grow well in an acidic soil.

Which type of chemical reaction takes place when farmers add calcium hydroxide to the soil?

- A decomposition
- B fertilisation
- C neutralisation
- D reduction

30 Which element in the table is a metal?

element	melting point in °C	density in g/cm <sup>3</sup>
<b>A</b>	-7	3.10
<b>B</b>	44	1.82
<b>C</b>	113	2.07
<b>D</b>	1083	8.92

31 Experiments are carried out to arrange metals X, Y and Z in order of decreasing reactivity.

The table shows the results.

experiment	X	Y	Z
Does the metal liberate hydrogen from dilute hydrochloric acid?	yes	no	yes
Is the metal oxide reduced by heating with carbon?	yes	yes	no

What is the order of reactivity of the metals?

	most reactive → least reactive		
<b>A</b>	X	Z	Y
<b>B</b>	Y	X	Z
<b>C</b>	Z	X	Y
<b>D</b>	Z	Y	X

32 Different forms of steel contain differing amounts of carbon.

Steel **P** contains a high proportion of carbon.

Steel **Q** contains a low proportion of carbon.

Which statement is correct?

- A **P** is stronger but more brittle than **Q**
- B **P** is stronger but less brittle than **Q**
- C **P** is less strong but more brittle than **Q**
- D **P** is less strong but less brittle than **Q**

33 Iron filings are left to rust in the apparatus shown.

Which letter indicates the water level when all the oxygen has reacted?

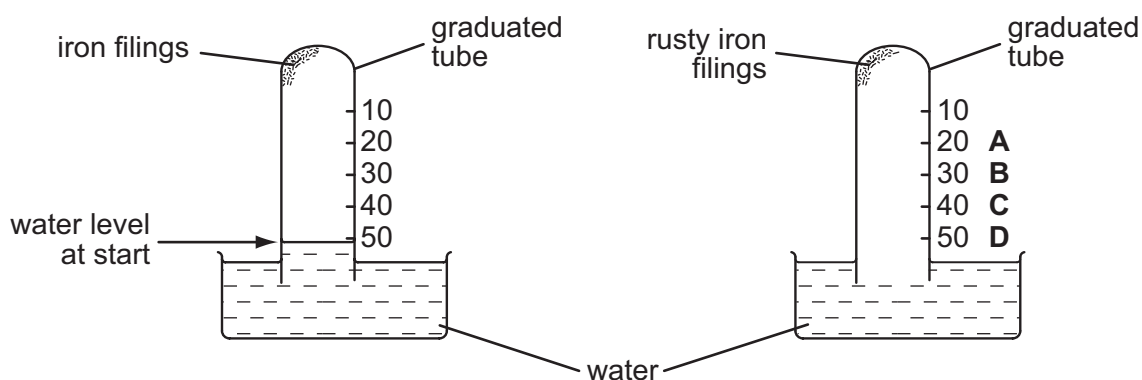

34 The following gases are present in car exhaust fumes.

- carbon dioxide
- carbon monoxide
- nitrogen
- nitrogen dioxide
- water vapour

Which of these gases is also present in unpolluted air?

- A nitrogen only
- B nitrogen and water vapour only
- C nitrogen, carbon dioxide and water vapour only
- D nitrogen, carbon monoxide, carbon dioxide and water vapour only

35 Desalination is the removal of sodium chloride from sea water.

Which method is used in the laboratory to desalinate sea water?

- A chromatography
- B crystallisation
- C distillation
- D filtration

36 A compound, **X**, has the molecular structure as shown.

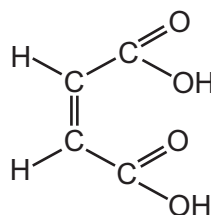

How can **X** be described?

- A both as an alkane and as an acid
  - B both as an alkene and as an acid
  - C both as an alkane and as an alcohol
  - D both as an alkene and as an alcohol
- 37 Which statement about the homologous series of alcohols is **not** true?
- A They all contain oxygen.
  - B They can be represented by a general formula.
  - C They exhibit a gradual change in physical properties.
  - D They have the same empirical formula.

38 The structures of four organic compounds are shown.

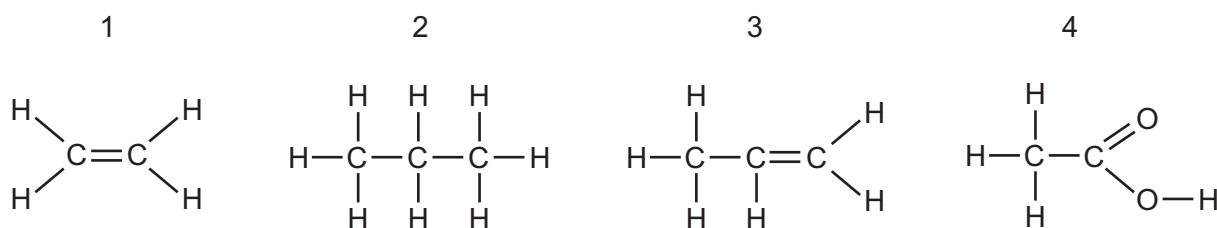

Which compounds decolourise aqueous bromine?

- A 1 and 2
- B 1 and 3
- C 2 and 4
- D 3 and 4

39 Methane is used as a fuel.

Which property is essential for this use?

- A It burns exothermically.
- B It is a gas.
- C It is odourless.
- D It has a low boiling point.

40 The following formula represents a monomer.

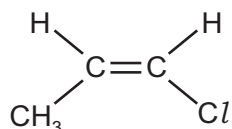

Which formula shows a part of the polymer chain formed from 3 molecules of the monomer?

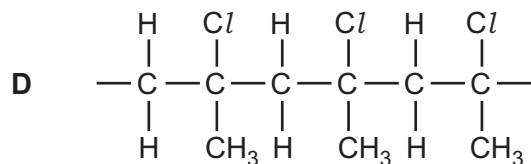
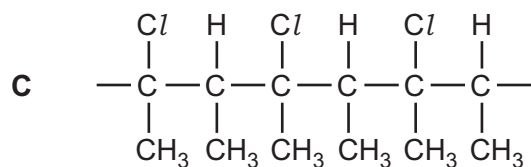
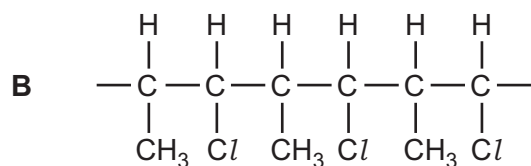
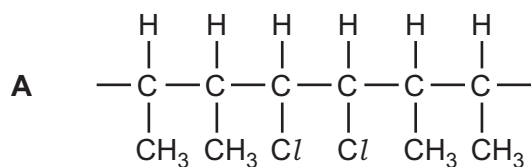

**DATA SHEET**  
**The Periodic Table of the Elements**

		Group										
		I	II	III	IV	V	VI	VII	0			
1	1											
7	9	3	4	5	6	7	8	9	10	2		
Li Lithium	Be Beryllium	H Hydrogen										
23	24	11	12	13	14	15	16	17	18	4		
Na Sodium	Mg Magnesium	Al Aluminium	Si Silicon	P Phosphorus	S Sulphur	Cl Chlorine	Ar Argon	Ne Neon	He Helium	20		
39	40	19	20	21	22	23	24	25	26	27		
K Potassium	Ca Calcium	Sc Scandium	Ti Titanium	V Vanadium	Cr Chromium	Mn Manganese	Fe Iron	Co Cobalt	Ni Nickel	Cu Copper		
85	88	37	38	39	40	41	42	43	44	45		
Rb Rubidium	Sr Strontium	Y Yttrium	Zr Zirconium	Nb Niobium	Mo Molybdenum	Tc Technetium	Ru Ruthenium	Rh Rhodium	Pd Palladium	Ag Silver		
133	137	55	56	57	72	73	74	75	76	77		
Cs Caesium	Ba Barium	La Lanthanum	Hf Hafnium	Ta Tantalum	W Tungsten	Re Rhenium	Os Osmium	Ir Iridium	Pt Platinum	Au Gold		
226	227	87	88	89	90	91	92	93	94	95		
Fr Francium	Ra Radium	Ac Actinium										
*58-71 Lanthanoid series												
90-103 Actinoid series												
140	141	144	150	152	157	162	165	167	169	173		
Ce Cerium	Pr Praseodymium	Nd Neodymium	Sm Samarium	Eu Europium	Gd Gadolinium	Dy Dysprosium	Ho Holmium	Er Erbium	Tm Thulium	Yb Ytterbium		
232	238	92	94	95	96	98	99	100	101	102		
Th Thorium	Pa Protactinium	U Uranium	Pu Plutonium	Am Americium	Cm Curium	Bk Berkelium	Es Einsteinium	Fm Fermium	Md Mendelevium	No Nobelium		
90	91	92	94	95	96	98	99	100	101	102		
Lu Lutetium	Yb Ytterbium	Lu Lutetium	La Lanthanum	Ce Cerium	Pr Praseodymium	Nd Neodymium	Pm Promethium	Sm Samarium	Eu Europium	Gd Gadolinium		
71	70	71	72	73	74	75	76	77	78	79		
Lu Lutetium	Yb Ytterbium	Lu Lutetium	La Lanthanum	Ce Cerium	Pr Praseodymium	Nd Neodymium	Pm Promethium	Sm Samarium	Eu Europium	Gd Gadolinium		
71	70	71	72	73	74	75	76	77	78	79		
Lu Lutetium	Yb Ytterbium	Lu Lutetium	La Lanthanum	Ce Cerium	Pr Praseodymium	Nd Neodymium	Pm Promethium	Sm Samarium	Eu Europium	Gd Gadolinium		
71	70	71	72	73	74	75	76	77	78	79		
Lu Lutetium	Yb Ytterbium	Lu Lutetium	La Lanthanum	Ce Cerium	Pr Praseodymium	Nd Neodymium	Pm Promethium	Sm Samarium	Eu Europium	Gd Gadolinium		

Key

a	<b>X</b>
b	b

a = relative atomic mass  
X = atomic symbol  
b = proton (atomic) number

The volume of one mole of any gas is 24 dm<sup>3</sup> at room temperature and pressure (r.t.p.).