

CANDIDATE
NAME

CENTRE
NUMBER

--	--	--	--	--

CANDIDATE
NUMBER

--	--	--	--

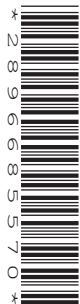

PHYSICS

5054/32

Paper 3 Practical Test

October/November 2018

2 hours

Candidates answer on the Question Paper.

Additional Materials: As listed in the Confidential Instructions.

READ THESE INSTRUCTIONS FIRST

Write your Centre number, candidate number and name on all the work you hand in.

Write in dark blue or black pen.

You may use an HB pencil for any diagrams or graphs.

Do not use staples, paper clips, glue or correction fluid.

DO NOT WRITE IN ANY BARCODES.

Answer **all** questions.

For each of the questions in Section A, you will be allowed to work with the apparatus for a maximum of 20 minutes. For the question in Section B, you will be allowed to work with the apparatus for a maximum of 1 hour.

You are expected to record all your observations as soon as these observations are made.

An account of the method of carrying out the experiments is **not** required.

Electronic calculators may be used.

You may lose marks if you do not show your working or if you do not use appropriate units.

At the end of the examination, fasten all your work securely together.

The number of marks is given in brackets [] at the end of each question or part question.

For Examiner's Use

1	
2	
3	
4	
Total	

This document consists of **11** printed pages and **1** blank page.

Section A

Answer **all** the questions in this section.

- 1 In this experiment, you will determine the power developed when sliding a wooden block across the bench.

You are provided with:

- a wooden block
- five 100 g masses
- a spring attached to the block with a piece of string
- a 30 cm ruler
- a metre rule
- a stopwatch.

Set up the apparatus as shown in Fig. 1.1.

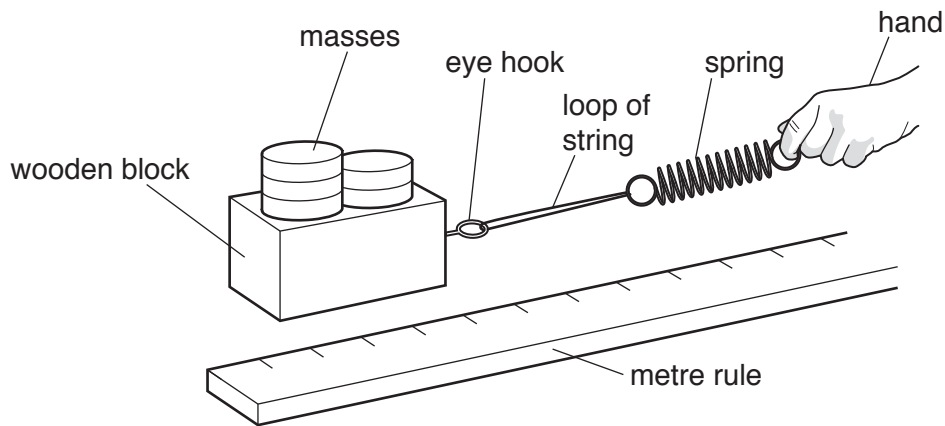

Fig. 1.1

- (a) (i) Pull the spring slowly to the right as shown in Fig. 1.1.

The spring stretches, as shown in Fig. 1.2, and the block **just** begins to slide. Hold the spring steady in this position.

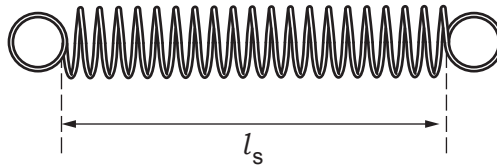

Fig. 1.2

Measure the stretched length l_s of the spring at this position.

$$l_s = \dots\dots\dots \text{ cm [1]}$$

- (ii) For the spring provided, measure the unstretched length l_u of the spring, as shown in Fig. 1.3.

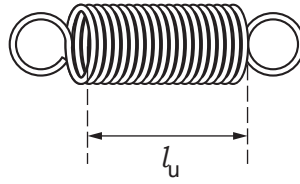

Fig. 1.3

$$l_u = \dots\dots\dots \text{ cm}$$

Use the equation $e = l_s - l_u$ to calculate the extension e of the spring.

$$e = \dots\dots\dots \text{ cm [1]}$$

- (iii) Use the equation $F = ke$ to calculate the force F applied by the spring, where $k = 0.25 \text{ N/cm}$. Give the unit of your answer.

$$F = \dots\dots\dots \text{ unit } \dots\dots\dots [1]$$

- (b) Pull the spring slowly to the right until the block just begins to slide on the bench.

Start the stopwatch and pull the block along the bench, keeping the extension of the spring constant.

Stop the stopwatch when the block has moved 20 cm.

Repeat and find the average value t for the time taken. Show your working.

$$t = \dots\dots\dots \text{ s [1]}$$

- (c) Use the equation $P = \frac{0.20F}{t}$ to calculate the power P developed.

$$P = \dots\dots\dots \text{ W [1]}$$

2 In this experiment, you will investigate filament lamps in series and in parallel.

You are provided with:

- a power supply
- a switch
- three identical filament lamps each in a holder
- an ammeter
- a voltmeter
- connecting leads
- a resistor, labelled R.

The Supervisor has set up the circuit as shown in Fig. 2.1.

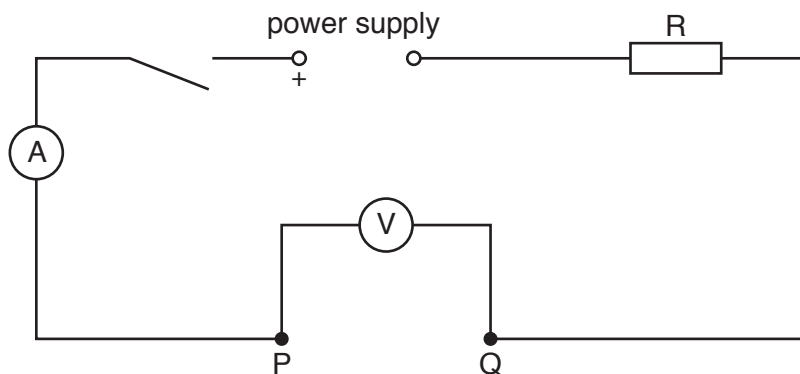

Fig. 2.1

(a) Connect one filament lamp between points P and Q.

Switch on the circuit.

Record the potential difference V and the current I in the table of Fig. 2.2.

Switch off.

[1]

(b) Repeat the procedure in (a) with:

- 2 filament lamps in series
- 2 filament lamps in parallel
- 3 filament lamps in parallel.

Switch off the circuit when you have completed your measurements.

[2]

(c) Use the equation $R_L = \frac{V}{I}$ to calculate the resistance R_L of each arrangement.

Record your answers in the table of Fig. 2.2.

[1]

	voltage/V	current/A	resistance/ Ω
single lamp			
2 lamps in series			
2 lamps in parallel			
3 lamps in parallel			

Fig. 2.2

- (d) When the circuit with a single filament lamp is switched on, the ammeter reading rises. The reading then decreases very slightly to a constant value within a very short period of time.

Suggest why the reading decreases.

.....
.....[1]

3 In this experiment, you will determine the magnification produced by a lens.

You are provided with:

- a power supply
- a lamp in a lamp holder
- a converging lens in a lens holder
- a screen
- a 30 cm ruler
- a metre rule.

(a) The apparatus is set up as shown in Fig. 3.1.

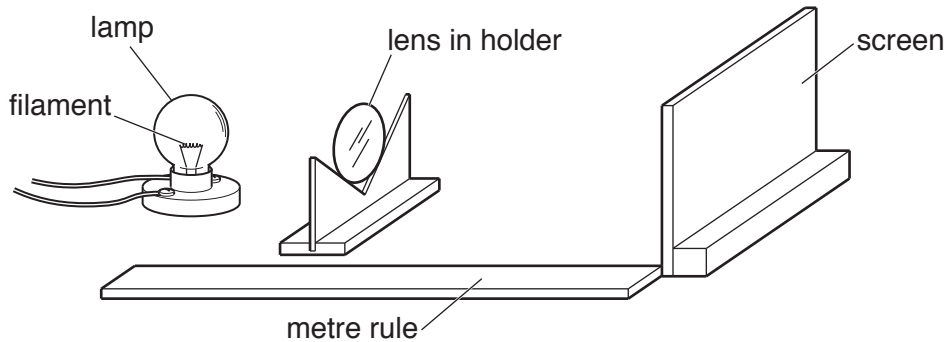

Fig. 3.1

Check that the filament of the lamp is at the 0.0 cm mark on the rule and that the screen is at the 100.0 cm mark on the rule so that the distance between the filament and the screen is 100.0 cm. The filament should be perpendicular to the metre rule and parallel to the screen, as shown in Fig. 3.2.

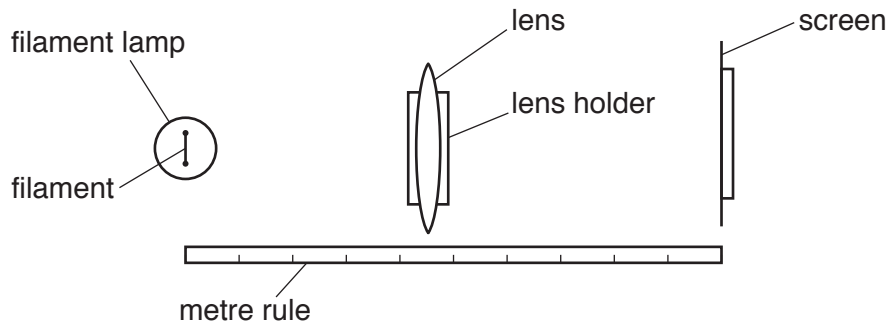

Fig. 3.2 (plan view)

Switch the lamp on.

Move the lens slowly towards the lamp until a sharply focussed **magnified** image of the filament is formed on the screen.

- On Fig. 3.2, mark the distance x from the filament to the lens.
- On the apparatus, measure the distance x between the filament and the lens.

$x = \dots\dots\dots$ cm [1]

(iii) Measure the length l_i of the image of the filament formed on the screen.

$l_i = \dots\dots\dots$ cm [1]

(b) Switch off the lamp.

The filament of the lamp is shown in Fig. 3.3.

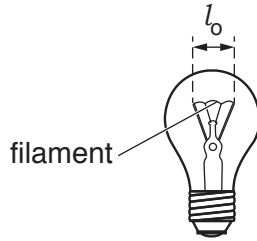

Fig. 3.3 (not to scale)

(i) Measure the length l_o for the filament lamp provided.

$l_o = \dots\dots\dots$ cm

(ii) Suggest why your measurement of l_o may not be accurate.

.....

 [1]

(c) Use the equation $m = \frac{l_i}{l_o}$ to calculate the magnification m produced by the lens.

$m = \dots\dots\dots$ [1]

(d) For this arrangement, where the lamp and the screen are 100.0 cm apart, theory states that

$$m = \frac{100 - x}{x}$$

where x is the distance measured in (a)(ii).

Explain whether your results support this theory.

.....

 [1]

Section B

- 4 In this experiment, you will use the results of moment calculations to determine the density of cooking oil.

You are provided with:

- a metre rule to act as a balance beam
- a 30 cm ruler
- a 200 g mass attached to a loop of string
- a 250 cm³ beaker attached to a loop of string
- a stand, boss and pivot
- a measuring cylinder
- a supply of cooking oil.

The Supervisor has set up the apparatus as shown in Fig. 4.1.

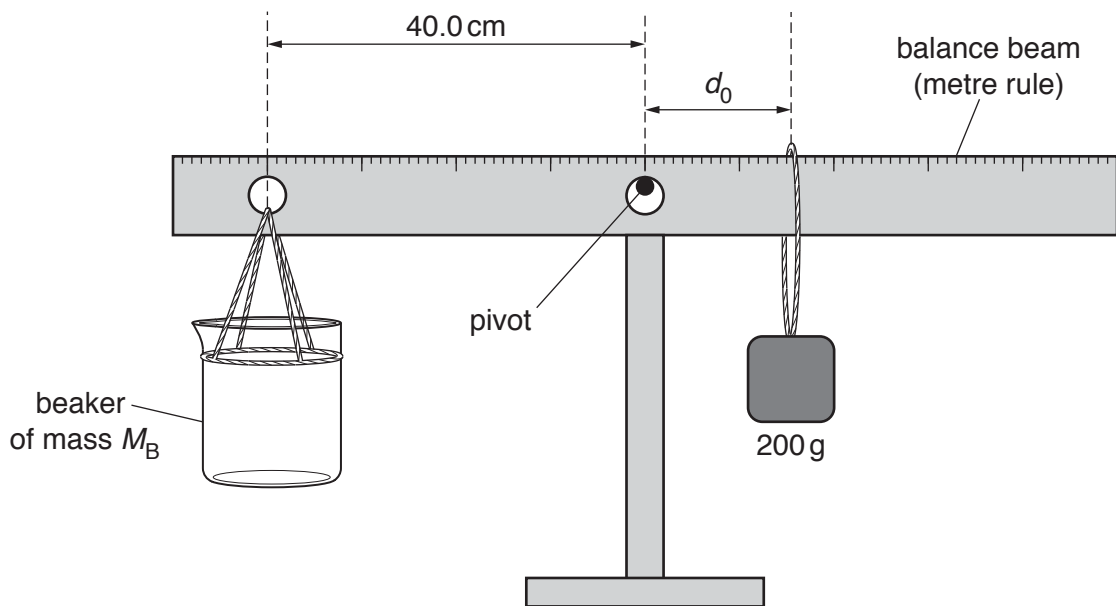

Fig. 4.1

Fig. 4.1 shows a 250 cm³ beaker tied to a balance beam (metre rule) at a fixed distance of 40.0 cm from the central pivot.

A mass of 200 g is free to move along the right-hand side of the beam.

At balance, the anticlockwise moment is equal to the clockwise moment.

- (a) If necessary, move the 200 g mass to ensure that the beam is horizontal.

Measure the horizontal distance d_0 from the pivot to the 200 g mass.

$$d_0 = \dots\dots\dots \text{ cm [1]}$$

- (b) Use the equation $M_B = 5d_0$ to calculate the mass M_B of the 250 cm³ beaker.

$$M_B = \dots\dots\dots \text{ g [1]}$$

- (c) Use the measuring cylinder to pour a volume V of 30 cm^3 of cooking oil into the beaker. Record the volume that you have added in the first column of the results table of Fig. 4.2.

Rebalance the beam by moving the 200g mass.

Measure the horizontal distance d from the 200g mass to the pivot.

$d = \dots\dots\dots$ cm

Record d in the second column in Fig. 4.2.

Use your answer to (b) and the equation

$$M = 5d - M_B,$$

to calculate the mass M of 30 cm^3 of oil. Record M in the third column of the results table.

$M = \dots\dots\dots$ g [2]

- (d) (i) Continue to add approximately 30 cm³ of oil at a time until there is a total of 150 cm³ of oil in the beaker.

Record the total volume V of oil in the first column of Fig. 4.2.

- (ii) Rebalance the beam each time you add some oil by moving the 200g mass.

Record the corresponding values of d in Fig. 4.2.

- (iii) Use the equation in (c) to calculate the mass M of the volume of the oil in the beaker.

Record your answers in the third column of Fig. 4.2.

- (iv) Write headings in the top row of the results table of Fig. 4.2.

volume / / /

Fig. 4.2

[4]

- (e) On the grid opposite, plot a graph of M on the y -axis against V on the x -axis.

Draw the straight line of best fit.

[4]

- (f) (i) Determine the gradient G of your graph.

$G = \dots\dots\dots$ [2]

- (ii) The equation used to calculate the density ρ of a substance is $\rho = \frac{M}{V}$.

State the relationship between the gradient of your graph and the density of the oil.

.....
 [1]

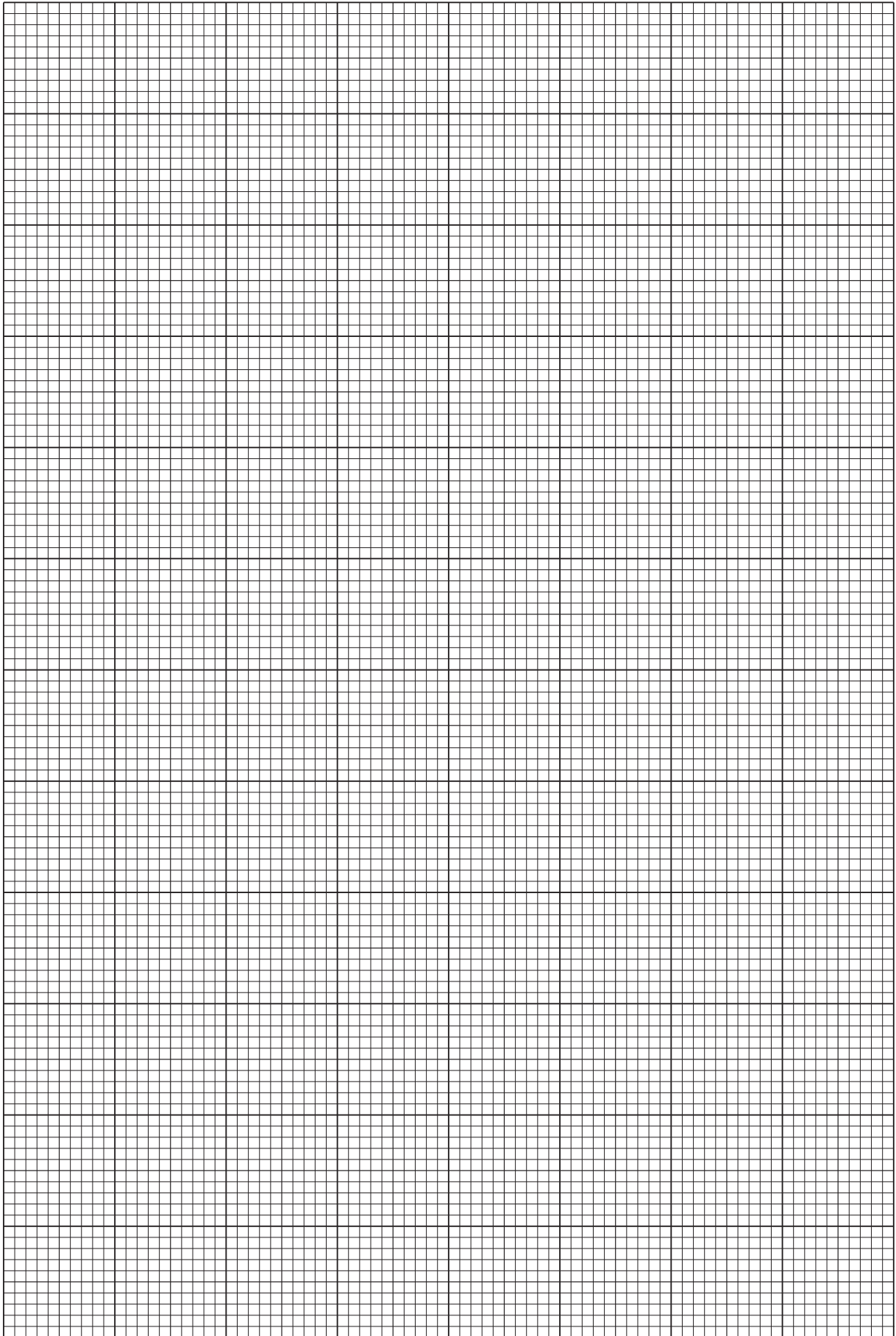

BLANK PAGE

Permission to reproduce items where third-party owned material protected by copyright is included has been sought and cleared where possible. Every reasonable effort has been made by the publisher (UCLES) to trace copyright holders, but if any items requiring clearance have unwittingly been included, the publisher will be pleased to make amends at the earliest possible opportunity.

To avoid the issue of disclosure of answer-related information to candidates, all copyright acknowledgements are reproduced online in the Cambridge International Examinations Copyright Acknowledgements Booklet. This is produced for each series of examinations and is freely available to download at www.cie.org.uk after the live examination series.

Cambridge International Examinations is part of the Cambridge Assessment Group. Cambridge Assessment is the brand name of University of Cambridge Local Examinations Syndicate (UCLES), which is itself a department of the University of Cambridge.