



UNIVERSITY OF CAMBRIDGE INTERNATIONAL EXAMINATIONS
General Certificate of Education Ordinary Level

CANDIDATE
NAME

CENTRE
NUMBER

--	--	--	--	--

CANDIDATE
NUMBER

--	--	--	--



PHYSICS

5054/31

Paper 3 Practical Test

May/June 2010

2 hours

Candidates answer on the Question Paper.

Additional Materials: As listed in the Confidential Instructions.

READ THESE INSTRUCTIONS FIRST

Write your Centre number, candidate number and name on all the work you hand in.

Write in dark blue or black pen.

You may use a pencil for any diagrams, graphs or rough working.

Do not use staples, paper clips, highlighters, glue or correction fluid.

DO NOT WRITE IN ANY BARCODES.

Answer **all** questions.

For each of the questions in Section A, you will be allowed to work with the apparatus for a maximum of 20 minutes. For the question in Section B, you will be allowed to work with the apparatus for a maximum of 1 hour.

You are expected to record all your observations as soon as these observations are made.

An account of the method of carrying out the experiments is **not** required.

At the end of the examination, fasten all your work securely together.

The number of marks is given in brackets [] at the end of each question or part question.

For Examiner's Use	
1	
2	
3	
4	
Total	

This document consists of **10** printed pages and **2** blank pages.



Section A

Answer **all** questions in this section.

- 1 *In this experiment, you will determine the density of the material from which a sphere is made.*

You have been provided with 20 glass spheres, two half-metre rules, two set squares and you have access to a top-pan balance.

- (a) Place the two half-metre rules parallel to one another, with a gap between the two, as shown in Fig. 1.1.

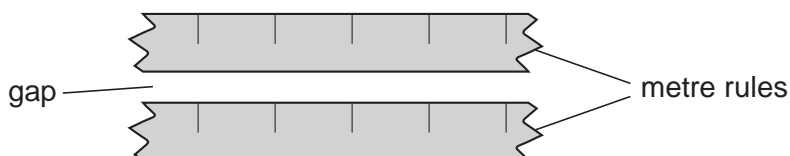

Fig. 1.1 (top view)

Ensure that the spheres are touching each other and are in a line.

Measure the total length L occupied by the 20 spheres.

$L = \dots\dots\dots$ [1]

- (b) State, with the aid of a diagram, a technique that you used to ensure that L was determined as accurately as possible.

.....
.....[1]

- (c) (i) Use your value of L to determine the average diameter d of a sphere.

For
Examiner's
Use

$$d = \dots\dots\dots$$

- (ii) Use the top-pan balance to determine the average mass m of a sphere.

$$m = \dots\dots\dots$$

- (iii) Calculate the density of the material from which the sphere is made, using the relationship

$$\text{density} = \frac{6m}{\pi d^3}.$$

$$\text{density} = \dots\dots\dots$$

[3]

[Total: 5]

2 In this experiment, you will determine the acceleration of a block of wood across the bench.

You have been provided with the apparatus shown in Fig. 2.1, nine 10g slotted masses, a stopwatch, a metre rule, a set square and a stand, clamp and boss to support the rule.

(a) The apparatus shown in Fig. 2.1 has been set up for you. **Do not remove the additional mass from the wooden block.**

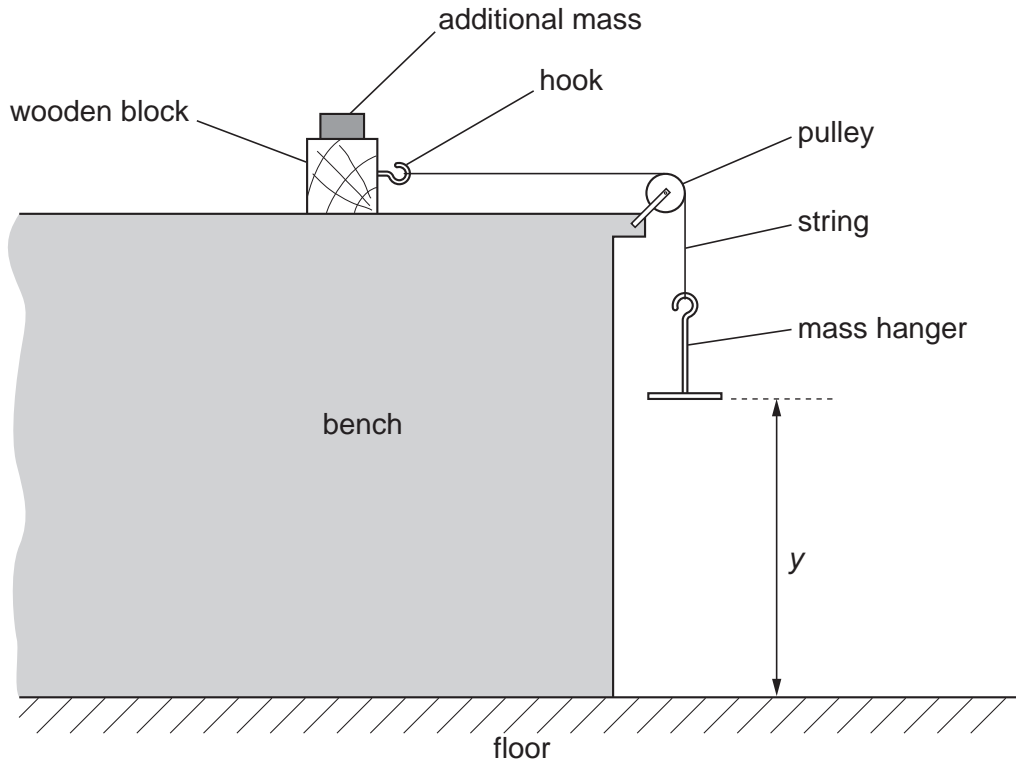

Fig. 2.1

Move the block away from the pulley until the mass hanger is just below the pulley. Clamp the metre rule vertically close to, but not touching, the mass hanger.

Measure the distance y from the base of the mass hanger to the floor.

$y = \dots\dots\dots$ [1]

(b) Explain, with the aid of a diagram, how you ensured that the metre rule was vertical.

.....
 [1]

- (c) (i) The mass of the mass hanger is given on the card. Place sufficient 10g slotted masses on the mass hanger to ensure that the wooden block **accelerates** across the bench when released.

For
Examiner's
Use

Record the total mass m of the mass hanger and the slotted masses.

$m = \dots\dots\dots$

- (ii) Move the block away from the pulley until the base of the mass hanger is at the height y above the floor, as measured in (a). Determine the average time t for the mass hanger to fall to the floor.

$t = \dots\dots\dots$

[2]

- (d) Calculate the acceleration a of the block, using the relationship

$$a = \frac{2y}{t^2} .$$

$a = \dots\dots\dots$ [1]

[Total: 5]

3 In this experiment, you will measure the focal length of a lens.

You have been provided with a converging lens, an illuminated cross-wire object, a lens holder, a screen, a metre rule and a 30 cm rule.

- (a) Determine the average diameter d of the cross-wire object.

$$d = \dots\dots\dots [1]$$

- (b) Set up the apparatus as shown in Fig. 3.1.

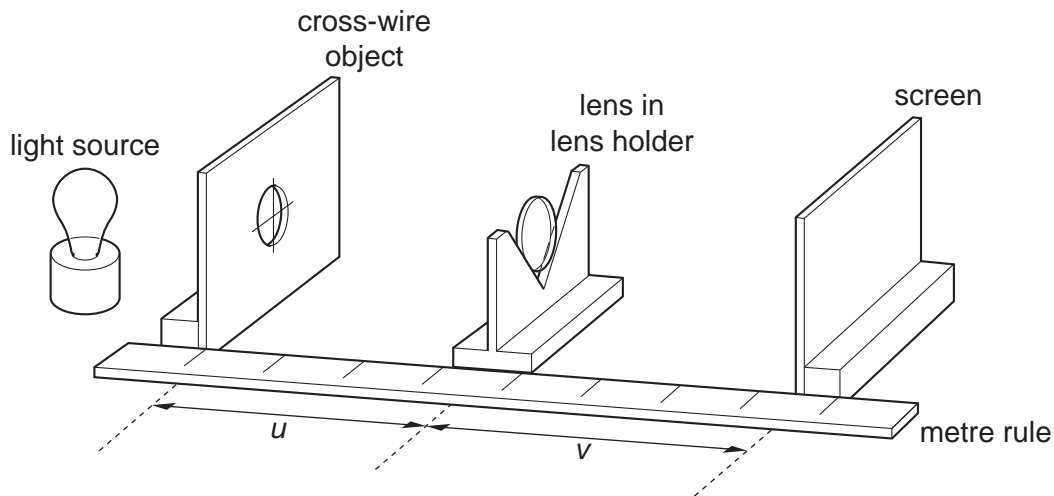

Fig. 3.1

Adjust the position of the lens until the distance u between the object and the lens is 20.0 cm. Adjust the position of the screen until a sharply-focused image of the cross-wire object is formed on the screen.

Determine

- (i) the distance v between the lens and the screen,

$$v = \dots\dots\dots$$

- (ii) the average diameter D of the image formed on the screen.

$$D = \dots\dots\dots$$

[2]

(c) Calculate

(i) the magnification m of the image, using the relationship

$$m = \frac{D}{d},$$

$$m = \dots\dots\dots$$

(ii) the focal length f of the converging lens, using the relationship

$$f = \frac{v}{(m + 1)}.$$

$$f = \dots\dots\dots$$

[2]

[Total: 5]

For
Examiner's
Use

Section B

- 4 In this experiment, you will investigate the discharging of a capacitor through a resistor.

You have been provided with a circuit consisting of a power supply, a resistor, a capacitor and a switch. You have also been provided with a voltmeter with two connecting leads and a stopwatch.

- (a) In the space below, draw a circuit diagram of the circuit, clearly labelling points A, B, C and D. The symbol for the capacitor has been drawn for you.

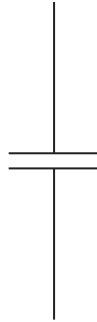

[1]

- (b) Connect the voltmeter between points A and B. Ensure that the positive terminal of the voltmeter is connected to point A.

Close the switch and record the potential difference V_0 between the terminals of the power supply.

$$V_0 = \dots\dots\dots [1]$$

- (c) Disconnect the voltmeter and then connect it between points C and D, with the positive terminal of the voltmeter connected to C.

Ensure that the switch is still closed and record the potential difference V_R across the resistor.

$$V_R = \dots\dots\dots [1]$$

- (d) When the switch is opened, the capacitor will start to discharge through the resistor.

Open the switch and start the stopwatch. Record the potential difference V_R across the resistor as a function of time t for a range of values of t , up to a maximum of $t = 80$ seconds.

Record your results in a table, including your result from (c). If you need more readings, close the switch, reset the stopwatch and repeat the procedure.

For
Examiner's
Use

[4]

- (e) Using the grid opposite, plot a graph of V_R/V against t/s . Draw a curved line of best fit.

[4]

- (f) Determine the gradient of your graph when $V_R = 0.5 V_0$.

gradient = [3]

- (g) Determine the time taken for the capacitor to discharge to $V_R = 0.37 V_0$.

time = [1]

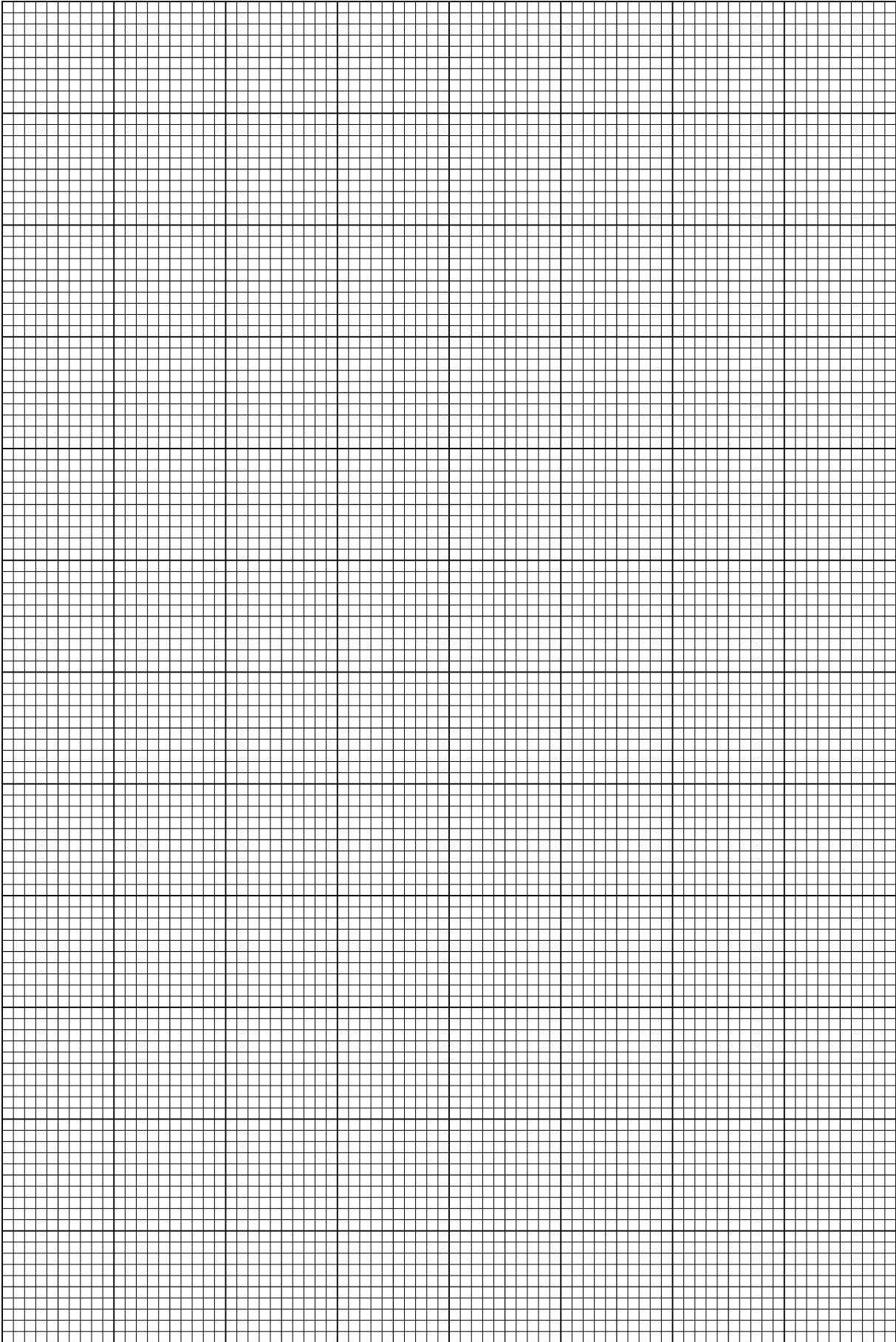

[Total: 15]

Permission to reproduce items where third-party owned material protected by copyright is included has been sought and cleared where possible. Every reasonable effort has been made by the publisher (UCLES) to trace copyright holders, but if any items requiring clearance have unwittingly been included, the publisher will be pleased to make amends at the earliest possible opportunity.

University of Cambridge International Examinations is part of the Cambridge Assessment Group. Cambridge Assessment is the brand name of University of Cambridge Local Examinations Syndicate (UCLES), which is itself a department of the University of Cambridge.