



UNIVERSITY OF CAMBRIDGE INTERNATIONAL EXAMINATIONS  
General Certificate of Education Ordinary Level

CANDIDATE  
NAME

CENTRE  
NUMBER

--	--	--	--	--

CANDIDATE  
NUMBER

--	--	--	--



**PHYSICS**

**5054/23**

Paper 2 Theory

**May/June 2010**

**1 hour 45 minutes**

Candidates answer on the Question Paper.

No Additional Materials are required.

**READ THESE INSTRUCTIONS FIRST**

Write your Centre number, candidate number and name on all the work you hand in.

Write in dark blue or black pen.

You may use a soft pencil for any diagrams, graphs or rough working.

Do not use staples, paper clips, highlighters, glue or correction fluid.

DO **NOT** WRITE IN ANY BARCODES.

**Section A**

Answer **all** questions.

Write your answers in the spaces provided on the Question Paper.

**Section B**

Answer any **two** questions.

Write your answers in the spaces provided on the Question Paper.

At the end of the examination, fasten all your work securely together.

The number of marks is given in brackets [ ] at the end of each question or part question.

For Examiner's Use	
Section A	
Q9	
Q10	
Q11	
Total	

This document consists of **16** printed pages and **4** blank pages.



Section A

For  
Examiner's  
Use

Answer **all** the questions in this section. Answer in the spaces provided.

- 1 A journey consists of two displacements: the first is 500 m in a northerly direction and the second is 200 m in an easterly direction.

(a) In the space below draw, to scale, a vector diagram of these displacements.

State the scale of your diagram.

On your diagram, show the two displacements and the resultant displacement.

Determine the size (magnitude) and direction of the resultant displacement.



scale = .....

size = .....

direction = .....

[3]

- (b) Another journey covers a distance of 700 m. Describe how it is possible that this journey has no resultant displacement.

.....

..... [1]

- 2 Fig. 2.1 shows a motor used to operate a lift (elevator). There is a man in the lift.

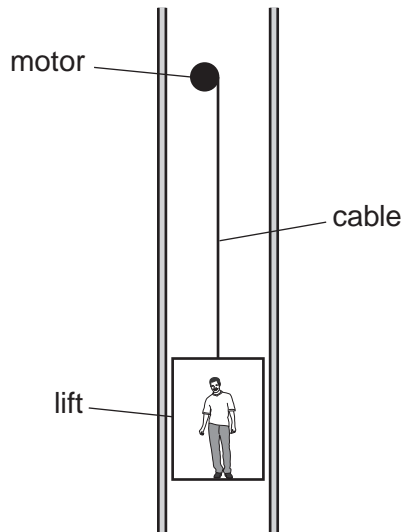

**Fig. 2.1** (not to scale)

The input power to the motor is 6200 watts.

- (a) Define the *watt*.

.....  
 ..... [2]

- (b) The lift and the man have a total mass of 580 kg. The lift moves up a distance of 12 m in 15 s.

- (i) Calculate the tension in the cable when the lift is moving at constant speed.

tension = ..... [1]

- (ii) Calculate the increase in potential energy of the lift and man.

potential energy = ..... [2]

- (iii) Calculate the efficiency of the motor.

efficiency = ..... [2]

3 Fig. 3.1 shows a metal roof. One side is facing the Sun.

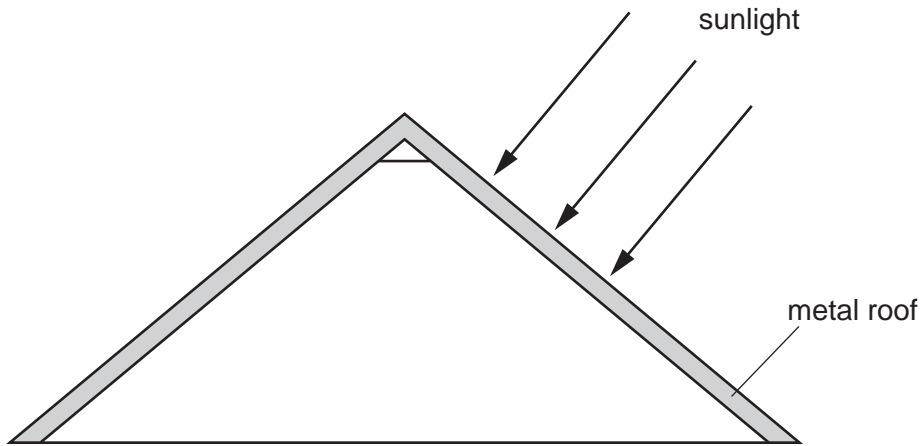

Fig. 3.1

(a) State the means by which thermal energy (heat) is transferred from the Sun to the Earth and explain why other means of thermal energy transfer are not involved.

.....  
..... [2]

(b) Describe how thermal energy is transferred through the metal roof from the heated surface.

.....  
.....  
..... [2]

(c) During the night, the metal roof loses  $1.2 \times 10^6 \text{ J}$  of thermal energy and its temperature falls by  $20 \text{ }^\circ\text{C}$ .

The specific heat capacity of the metal in the roof is  $400 \text{ J}/(\text{kg } ^\circ\text{C})$ .

Calculate the mass of metal in the roof.

mass = ..... [2]

4 A student notices puddles of water on a road, as shown in Fig. 4.1.



Fig. 4.1

Later in the day, he passes the puddles again and some of the water has evaporated.

(a) State two changes to the atmospheric conditions that would cause the water to evaporate faster.

1. ....

2. ....

[2]

(b) Explain, in terms of molecules, what happens during evaporation.

.....  
.....  
.....  
.....  
.....

[2]

- 5 Fig. 5.1 shows a ray of light entering a semi-circular glass block and striking the glass surface at M, the mid-point of the straight face.

For  
Examiner's  
Use

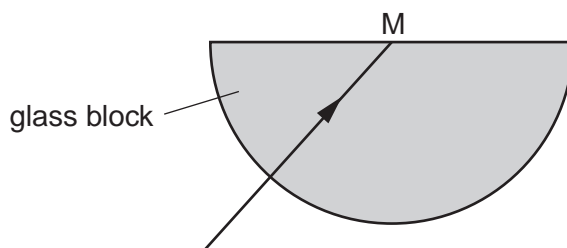

Fig. 5.1

- (a) The ray of light strikes the glass surface at M with an angle of incidence  $C$  equal to the critical angle of light in glass.

- (i) State what is meant by *critical angle*.

.....  
..... [1]

- (ii) On Fig. 5.1, mark and label the angle  $C$ . [1]

- (iii) On Fig. 5.1, continue the ray of light after it strikes the glass surface at M. [1]

- (b) Fig. 5.2 shows a second ray of light striking M.

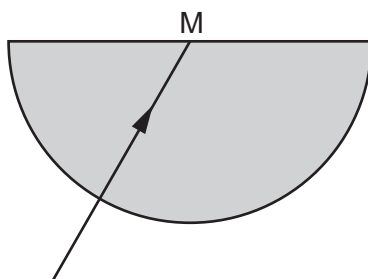

Fig. 5.2

This ray has an angle of incidence at M smaller than the critical angle.

On Fig. 5.2, continue this ray of light after it strikes the glass surface at M. [1]

- (c) The refractive index of this glass is 1.5. A third ray of light enters the block from air with an angle of incidence of  $50^\circ$ . Calculate the angle of refraction.

angle= ..... [2]

6 (a) An aeroplane becomes positively-charged as it flies through the air, because it loses particles from its metal surface.

(i) State the name of the particles lost from the metal surface.

.....[1]

(ii) The tyres of the aeroplane are made from an electrical conductor.

Explain what happens to the charge on the aeroplane when it lands.

.....  
.....[2]

(b) Suggest why it is necessary to keep an aeroplane connected electrically to earth during refuelling.

.....  
.....[2]

7 Fig. 7.1 shows a compass.

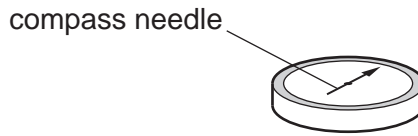

Fig. 7.1

The compass needle is a small magnet free to rotate. The head of the arrow on the compass needle is an N-pole.

(a) A bar magnet is placed between two compasses, as shown in Fig. 7.2.

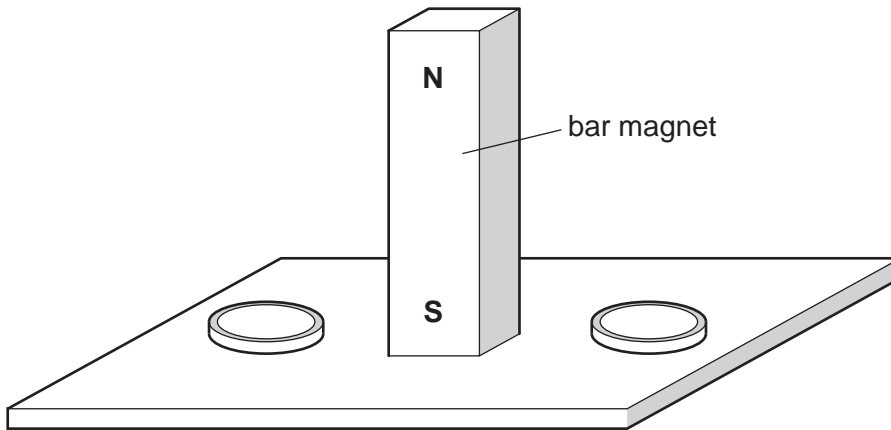

Fig. 7.2

On Fig. 7.2, draw the needles inside the two compasses and mark the N-pole of both compass needles. [2]

(b) Fig. 7.3 shows the structure of a relay.

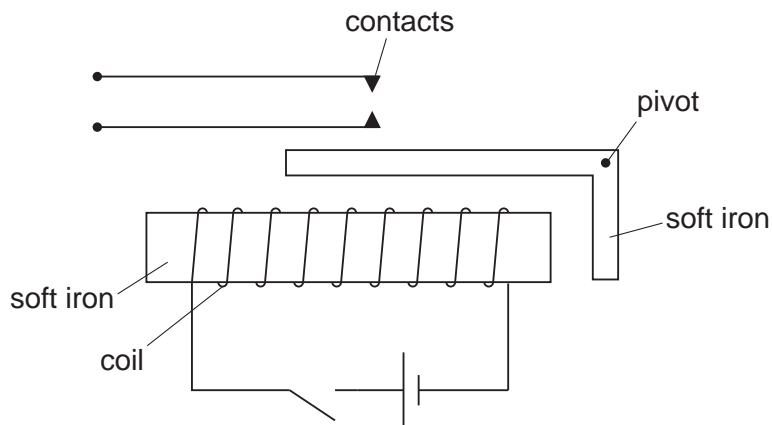

Fig. 7.3

Explain how closing the switch causes the contacts to close.

.....

.....

.....

[2]



(c) Fig. 7.4 is a circuit that includes a relay.

For  
Examiner's  
Use

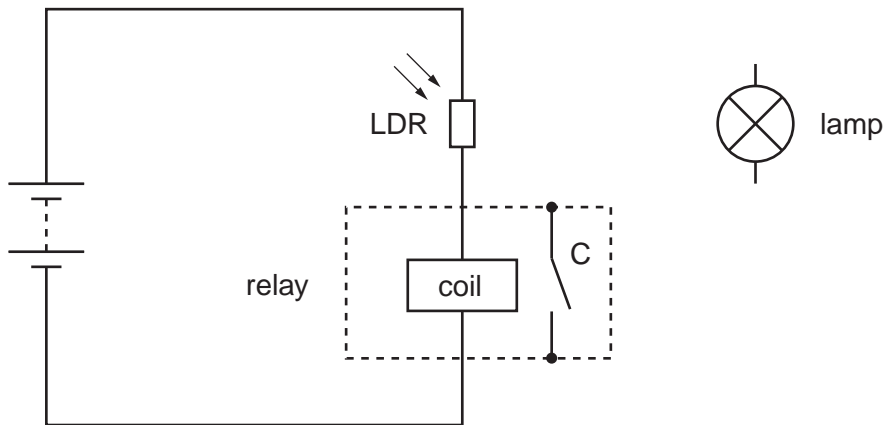

**Fig. 7.4**

When light shines on the light-dependent resistor (LDR), the relay contacts C close.

(i) State what happens to the resistance of the LDR when light falls on it.

.....[1]

(ii) The circuit for the lamp, as shown in Fig. 7.4, is not complete.

On Fig. 7.4, draw the connections to the lamp, the contacts C and the battery that cause the lamp to switch on when light shines on the LDR. [2]

8 A radioactive rock emits gamma-rays. A teacher plans an experiment to show a class that the emission of gamma-rays from the rock is random in time.

(a) (i) State the apparatus that the teacher needs to detect the gamma-rays.

.....  
.....[1]

(ii) State one safety precaution that the teacher must take.

.....  
.....[1]

(iii) Describe how the experiment is performed.

.....  
.....  
.....  
.....  
.....  
.....  
.....[2]

(b) Describe what is meant by a *gamma-ray*.

.....  
.....[2]

**BLANK PAGE**

**Please turn over for Section B.**

Section B

Answer **two** questions from this section. Answer in the spaces provided.

For  
Examiner's  
Use

9 Fig. 9.1 shows a car braking on a road and coming to rest.

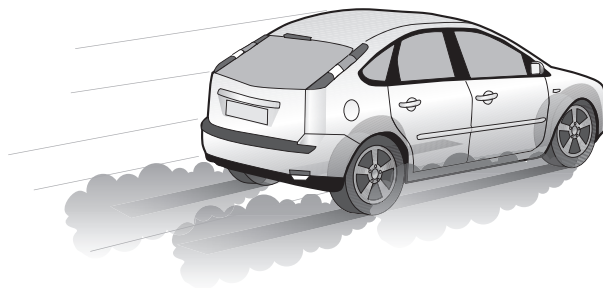

Fig. 9.1

(a) Explain what is meant by

(i) the *thinking distance*,

.....  
.....[1]

(ii) the *braking distance*.

.....  
.....[1]

(b) An engineer conducts a test on the car and finds that the braking distance is greater when the car is fully loaded than when it is unloaded.

(i) Apart from the road conditions, state what must be kept the same in the test.

.....[1]

(ii) Explain why the car has a greater braking distance when fully loaded.

.....  
.....[1]

(c) State and explain how one road condition affects the braking distance of the car. Use ideas about friction in your answer.

.....  
.....[2]

(d) Explain how wider tyres affect the pressure of the car on the surface of the road.

.....  
.....[1]

(e) The car has a total mass of 900 kg and is travelling at 20 m/s. At time  $t = 0$ , the driver sees an accident ahead. He applies the brakes at  $t = 0.60$  s to stop the car. After the brakes are applied, the car comes to rest in a further 4.0 s.

(i) Calculate the deceleration of the car as it brakes.

deceleration = ..... [2]

(ii) Calculate the braking force acting on the car.

force = ..... [2]

(iii) On Fig. 9.2, draw a speed-time graph for the car as it brakes.

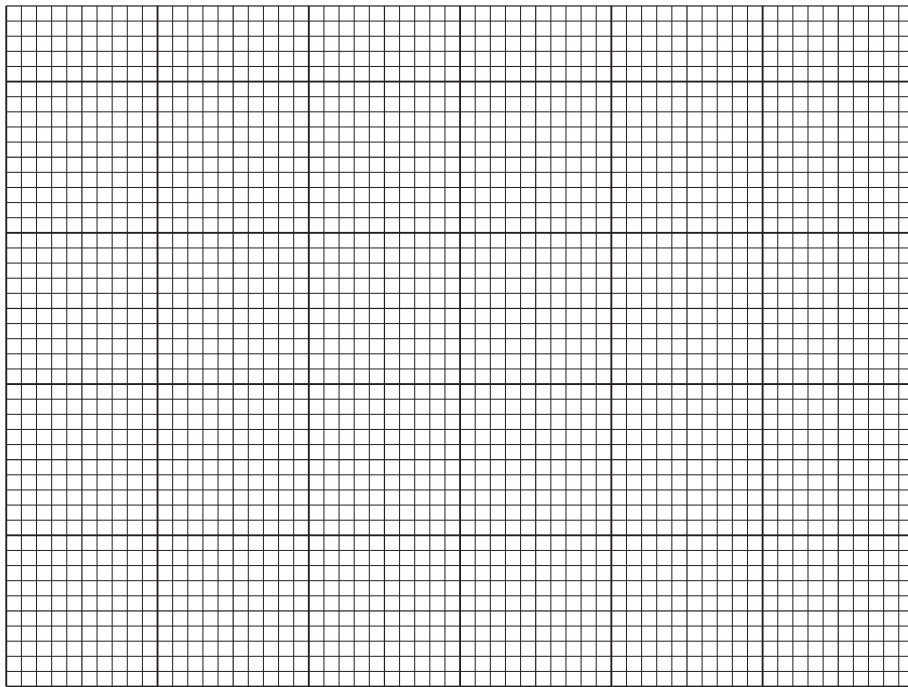

Fig. 9.2

[3]

(iv) State how your graph in (iii) can be used to find the total distance travelled by the car.

.....  
..... [1]

10 (a) Describe a method for measuring the speed of sound in air. In your account, state clearly

- how the sound is made,
- what measurements are taken,
- how the result is calculated,
- one precaution to produce an accurate result.

.....  
.....  
.....  
.....  
.....  
.....  
.....  
.....  
.....  
.....  
.....  
.....  
.....  
.....  
.....  
.....  
.....  
.....  
.....  
.....  
..... [5]

(b) Ultrasound is used in quality control to detect cracks in metal.

Pulses of ultrasound are sent into the metal from a transmitter. A detector is placed next to the transmitter on the front surface of the metal.

Fig. 10.1 shows the oscilloscope trace of the ultrasound pulses produced if the metal contains no cracks.

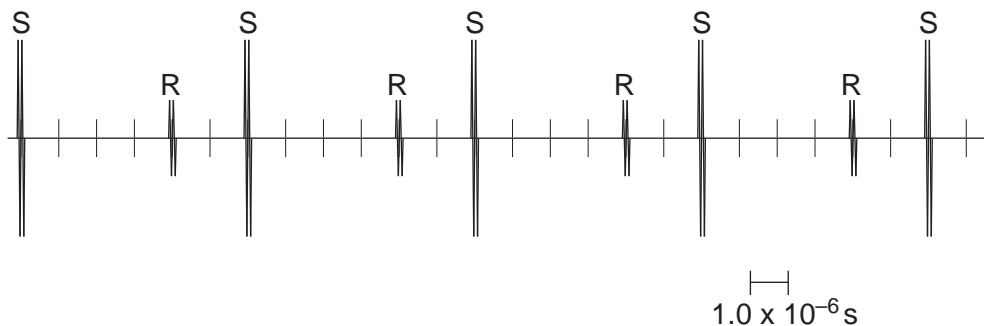

Fig. 10.1

One division along the x-axis represents  $1.0 \times 10^{-6}$  s.

Pulses labelled S are the pulses initially sent out from the transmitter. Each pulse labelled R is the reflection from the back surface of the metal of the previous pulse S.

(i) State what is meant by *ultrasound*.

.....  
..... [2]

(ii) Use Fig. 10.1 to calculate the number of pulses sent out by the source in one second.

number = ..... [2]

(iii) Suggest two reasons why the amplitude of R is less than the amplitude of S.

1. ....  
.....  
2. ....  
..... [2]

(iv) Some time later, the piece of metal is tested again. It now has a small crack half-way between the front surface and the back surface.

On Fig. 10.1, draw the position and size of the pulses produced by this crack.

Label each of these pulses C. [2]

(v) A second beam of ultrasound has a frequency of  $8.0 \times 10^6$  Hz and a speed of 4000 m/s in the metal .

Calculate the wavelength of this ultrasound in the metal.

wavelength = ..... [2]

11 (a) Describe an experiment, including an ammeter and a voltmeter, to show how the resistance of a wire varies with temperature. Draw a circuit diagram.

.....  
 .....  
 .....  
 .....  
 .....  
 ..... [4]

(b) The filament in a lamp is made from metal wire.

(i) Describe the variation with temperature of the resistance of the filament lamp.

.....  
 .....  
 ..... [2]

(ii) On Fig. 11.1, sketch a graph of the variation of the current in the filament against the potential difference (p.d.) across it.



Fig. 11.1

[2]



(c) Fig. 11.2 is a circuit used to monitor changes in room temperature.

For  
Examiner's  
Use

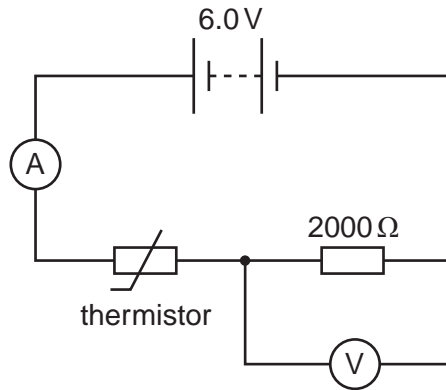

Fig. 11.2

A thermistor is connected in series with a 6.0V battery and a 2000Ω resistor.

(i) The temperature of the room increases. State and explain what happens to

1. the reading on the ammeter,

.....  
 ..... [2]

2. the reading on the voltmeter.

.....  
 ..... [2]

(ii) At a certain temperature, the reading on the voltmeter is 3.8V. Calculate the resistance of the thermistor at this temperature.

resistance = ..... [3]





---

Permission to reproduce items where third-party owned material protected by copyright is included has been sought and cleared where possible. Every reasonable effort has been made by the publisher (UCLES) to trace copyright holders, but if any items requiring clearance have unwittingly been included, the publisher will be pleased to make amends at the earliest possible opportunity.

University of Cambridge International Examinations is part of the Cambridge Assessment Group. Cambridge Assessment is the brand name of University of Cambridge Local Examinations Syndicate (UCLES), which is itself a department of the University of Cambridge.