

UNIVERSITY OF CAMBRIDGE INTERNATIONAL EXAMINATIONS
General Certificate of Education Ordinary Level

METALWORK

6040/02

Paper 2 Practical Test

October/November 2005

3 hours

Additional Materials:
As listed in Instructions to Supervisors

INSTRUCTIONS TO CANDIDATES

All dimensions are in millimetres unless stated otherwise.

This document consists of **4** printed pages and **2** blank pages.



From the materials supplied you are to make the GATE LATCH shown in the drawings.

All dimensions are in millimetres.

The following materials are supplied:

Part 1 One piece BDMS $20 \times 3 \times 88$ long. Both ends squared.

Part 2 One piece BDMS $20 \times 3 \times 55$ long. Both ends squared.

Part 3 One piece BDMS $20 \times 5 \times 78$ long.

Part 4 One piece BDMS 6 diameter $\times 30$ long, prepared prior to the examination.

One M6 $\times 15$ long cheese head or round head screw and nut.

One bag in which to enclose work.

Two tie-on labels.

Notes

Working Procedures

- A Part 1 is bent to 90° as shown using the former provided.
- B Part 1 is silver soldered to Part 2 and the joint filed flat.
- C Part 4 is riveted to Part 3 and filed flat.
- D The nut is used to lock the screw into Part 3 so that the screw can turn in Part 2.
- E It will be necessary to 'ease' edge **X** on Part 2 to allow Part 4 to move freely.

General Notes

- A second supply of material is **not** allowed. If you make a mistake do your best to work as near to the dimensions given in the drawing as possible.
- Any dimensions omitted are left to your discretion.
- Attempt to complete all the work but remember that a partly completed piece of work of good quality may gain more marks than one which is complete but inaccurate or poorly finished.
- Clean up all parts by draw filing. Emery cloth or similar must **not** be used.
- Write your **name and examination number** on the labels supplied, attach **one** to your work and **the other** to the bag in which your work is enclosed. Put into the bag all worked and unworked materials, with the exception of waste.

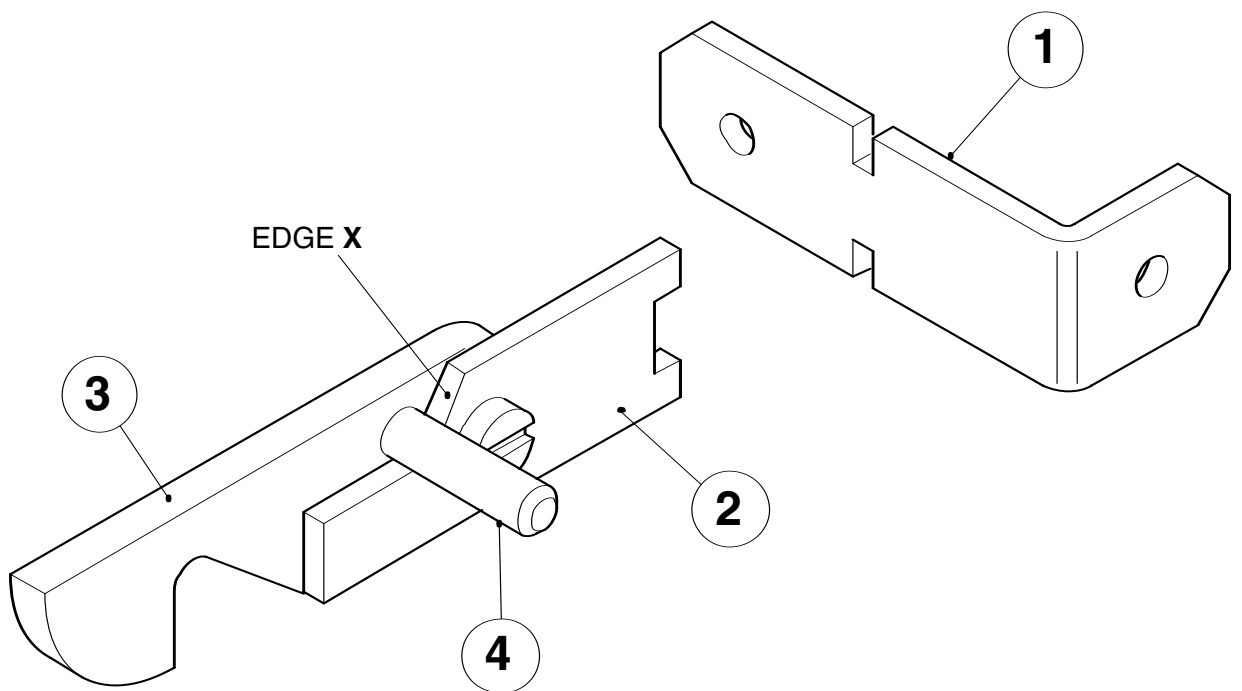

GATE LATCH

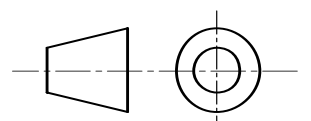

Dimensions in millimeters

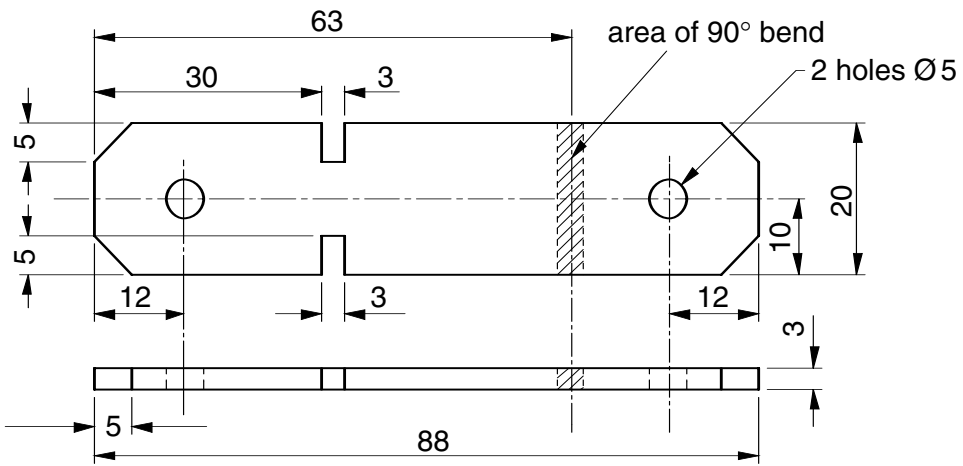

PART 1

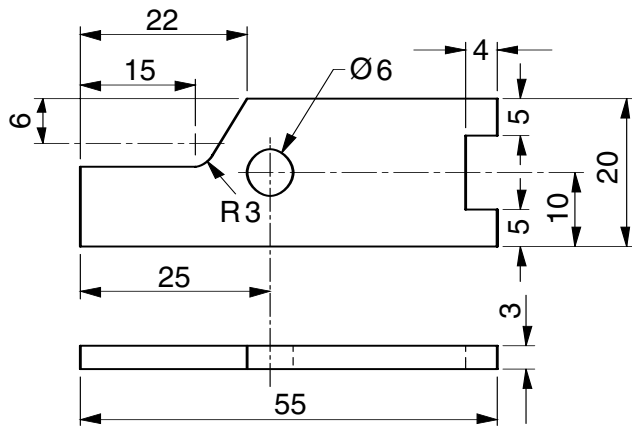

PART 2

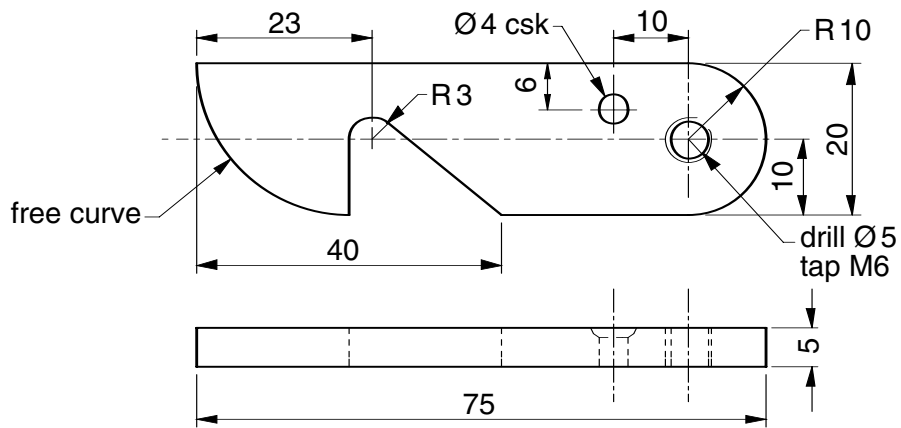

PART 3

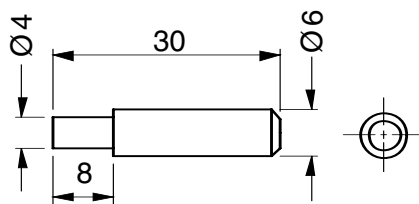

PART 4

BLANK PAGE

FOLD OUT THIS PAGE

BLANK PAGE

Every reasonable effort has been made to trace all copyright holders where the publishers (i.e. UCLES) are aware that third-party material has been reproduced. The publishers would be pleased to hear from anyone whose rights they have unwittingly infringed.

University of Cambridge International Examinations is part of the University of Cambridge Local Examinations Syndicate (UCLES), which is itself a department of the University of Cambridge.