



UNIVERSITY OF CAMBRIDGE INTERNATIONAL EXAMINATIONS
General Certificate of Education Ordinary Level

CANDIDATE
NAME

CENTRE
NUMBER

--	--	--	--	--

CANDIDATE
NUMBER

--	--	--	--



MATHEMATICS (SYLLABUS D)

4024/22

Paper 2

May/June 2011

2 hours 30 minutes

Candidates answer on the Question Paper.

Additional Materials: Geometrical instruments
 Electronic calculator

READ THESE INSTRUCTIONS FIRST

Write your Centre number, candidate number and name on all the work you hand in.
Write in dark blue or black pen.

You may use a pencil for any diagrams or graphs.

Do not use staples, paper clips, highlighters, glue or correction fluid.

DO **NOT** WRITE IN ANY BARCODES.

Section A

Answer **all** questions.

Section B

Answer any **four** questions.

If working is needed for any question it must be shown in the space below that question.

Omission of essential working will result in loss of marks.

You are expected to use an electronic calculator to evaluate explicit numerical expressions.

If the degree of accuracy is not specified in the question, and if the answer is not exact, give the answer to three significant figures. Give answers in degrees to one decimal place.

For π , use either your calculator value or 3.142, unless the question requires the answer in terms of π .

The number of marks is given in brackets [] at the end of each question or part question.

The total of the marks for this paper is 100.

For Examiner's Use

--

This document consists of **24** printed pages.



Section A [52 marks]Answer **all** questions in this section.*Do not
write in this
margin*

1 (a) Express as a single fraction in its simplest form

(i) $\frac{1}{2x} - \frac{2}{5x}$,

Answer [1]

(ii) $\frac{4}{x} + \frac{7}{x-3}$.

Answer [2]

(b) A function is defined by $f(x) = \frac{2x-3}{4}$.

(i) Find $f(2)$.

Answer [1]

(ii) Given that $f^{-1}(x) = cx + d$, find the values of c and d .

Answer $c = \dots\dots\dots d = \dots\dots\dots$ [2]

(iii) Given that $f(g) = -g$, find the value of g .

Answer [2]

Do not
write in this
margin

2 (a) The formula for the area of a trapezium is $A = \frac{1}{2}h(c + d)$.

(i) Find an expression for c in terms of A , h and d .

Do not
write in this
margin

Answer [2]

(ii)

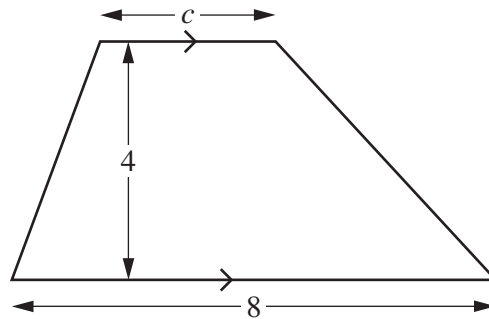

The diagram shows a trapezium with dimensions given in centimetres.
The perpendicular distance between the parallel lines is 4 cm.
The area of the trapezium is 22 cm^2 .

Find c .

Answer [1]

(b)



*Do not
write in this
margin*

In the diagram, the shaded area represents a rectangular picture frame.
The outer rectangle is 32 cm by 20 cm.
The inner rectangle is 26 cm by 14 cm.
All measurements are given to the nearest centimetre.

- (i) Calculate the lower bound of the perimeter of the outer rectangle.

Answer cm [2]

- (ii) Calculate the upper bound of the area of the frame.

Answercm² [3]

3



*Do not
write in this
margin*

The letters spelling the word BANANA are written on six tiles.

- (a) Find the probability that a tile chosen at random has the letter N on it.
Give your answer as a fraction in its simplest form.

Answer [1]

- (b) The six tiles are placed in a bag.
Three tiles are chosen at random without replacement.
The first is placed in Position 1, the second in Position 2 and the third in Position 3.

_____ _____ _____
Position 1 Position 2 Position 3

- (i) Find the probability that the three tiles spell BAN.
Give your answer as a fraction in its simplest form.

Answer [2]

- (ii) The tiles are now replaced and the process is repeated.

Find the probability that the three tiles spell either ANN or ANA.
Give your answer as a fraction in its simplest form.

Answer [2]

4 u_n is the n th term of the sequence 4, 7, 10, 13,

(a) (i) Write down an expression, in terms of n , for u_n .

Answer [1]

(ii) Hence find the 20th term of the sequence.

Answer [1]

(b) v_n is the n th term of the sequence 15, 13, 11, 9,

(i) Write down an expression, in terms of n , for v_n .

Answer [1]

(ii) w_n is the n th term of another sequence that is obtained by multiplying u_n by v_n .

Given that $w_n = 17 + kn - 6n^2$, find k .

Answer [1]

Do not
write in this
margin

5

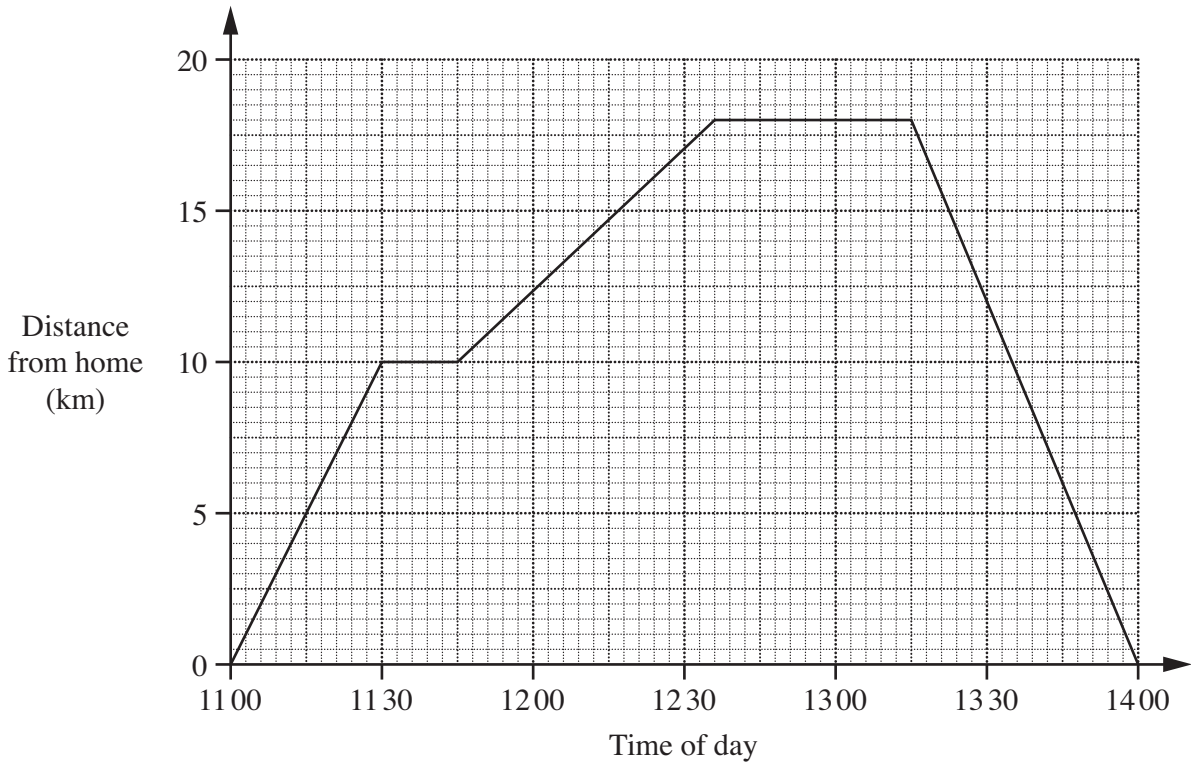
Do not
write in this
margin

The distance-time graph shows Ravi's cycle journey.
 He sets out from home and cycles to a park.
 After a short stop at the park, he then continues his journey to a shopping centre.
 He stops for lunch at the shopping centre before cycling home.

(a) At what time does Ravi arrive at the park?

Answer [1]

(b) How many minutes does Ravi spend at the shopping centre?

Answer minutes [1]

(c) How far is the park from the shopping centre?

Answer km [1]

- (d) At what speed does Ravi cycle home?
Give your answer in kilometres per hour.

*Do not
write in this
margin*

Answer km/h [1]

- (e) Between which two places did Ravi cycle slowest?

Answer and [1]

- (f) Salim, Ravi's brother, sets out from home at 11 15.
He cycles directly to the shopping centre at a constant speed of 15 km/h.

Who arrives at the shopping centre first?
How many minutes later does his brother arrive?

Answer arrives first and his brother arrives minutes later. [2]

- 6 The pie chart, not drawn accurately, represents the weekly income of the five employees in a small British company in 2009.

Do not write in this margin

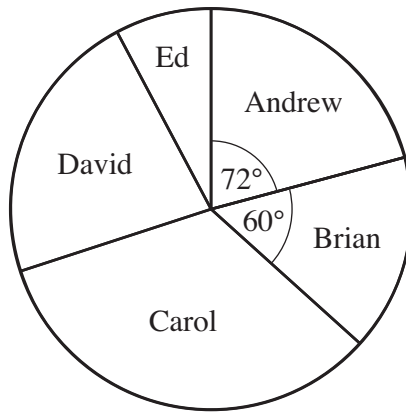

Andrew’s weekly income is represented by a sector with an angle of 72°.
 Brian’s weekly income is represented by a sector with an angle of 60°.

- (a) Andrew’s weekly income was £270.

Find the total weekly income of the five employees.

Answer £ [1]

- (b) Calculate Brian’s weekly income.

Answer £ [1]

- (c) Carol’s weekly income was £405.

Calculate the angle of the sector representing Carol’s weekly income.

Answer [1]

- (d) David's weekly income was twice as much as Ed's weekly income.

Calculate David's weekly income.

Do not
write in this
margin

Answer £ [2]

- (e) Andrew paid 20% of his weekly income of £270 as tax.
He also paid 6% of his weekly income of £270 towards his pension.

How much of his weekly income did he have left after paying tax and pension?

Answer £ [2]

- (f) Carol paid 20% of her weekly income of £405 as tax.
She also paid $x\%$ of her weekly income towards her pension.
She then had £287.55 of her weekly income left.

Find x .

Answer [3]

- (g) Andrew's weekly income of £270 in 2009 was 8% more than his weekly income in 2008.

Find his weekly income in 2008.

Answer £ [2]

7 (a)

Do not write in this margin

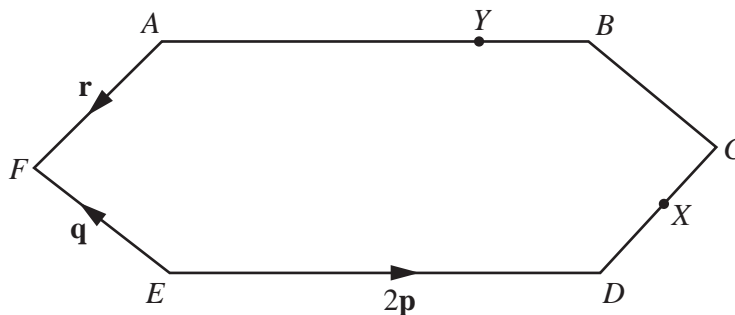

In the diagram, $ABCDEF$ is a hexagon with rotational symmetry of order 2.

$\vec{ED} = 2\mathbf{p}$, $\vec{EF} = \mathbf{q}$ and $\vec{AF} = \mathbf{r}$.

X is the midpoint of CD and Y is the point on AB such that $AY : YB$ is $3 : 1$.

(i) How many lines of symmetry does $ABCDEF$ have?

Answer [1]

(ii) Express, as simply as possible, in terms of one or more of the vectors \mathbf{p} , \mathbf{q} and \mathbf{r} ,

(a) \vec{EA} ,

Answer [1]

(b) \vec{FC} ,

Answer [1]

(c) \vec{FY} ,

Answer [1]

(d) \vec{YX} .

Answer [1]

(b)

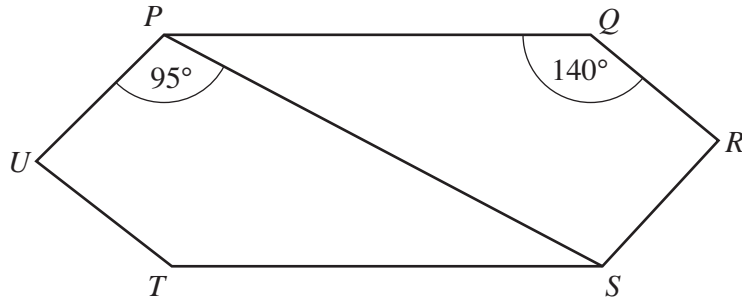

Do not write in this margin

$PQRSTU$ is a similar hexagon to $ABCDEF$.
 $\widehat{UPS} = 95^\circ$ and $\widehat{PQR} = 140^\circ$.

Find

(i) \widehat{QPS} ,

Answer [1]

(ii) \widehat{PSR} ,

Answer [1]

(iii) \widehat{PUT} .

Answer [1]

Section B [48 marks]Answer **four** questions in this section.

Each question in this section carries 12 marks.

*Do not
write in this
margin*

8 (a) $\mathbf{A} = \begin{pmatrix} 4 & 3 \\ -1 & 1 \end{pmatrix}$ and $\mathbf{B} = \begin{pmatrix} 5 & 4 \\ -3 & -2 \end{pmatrix}$.

Find

(i) $2\mathbf{A} - \mathbf{B}$,

Answer

[2]

(ii) \mathbf{B}^{-1} .

Answer

[2]

(b) The diagram shows triangles A, B and C.

Do not write in this margin

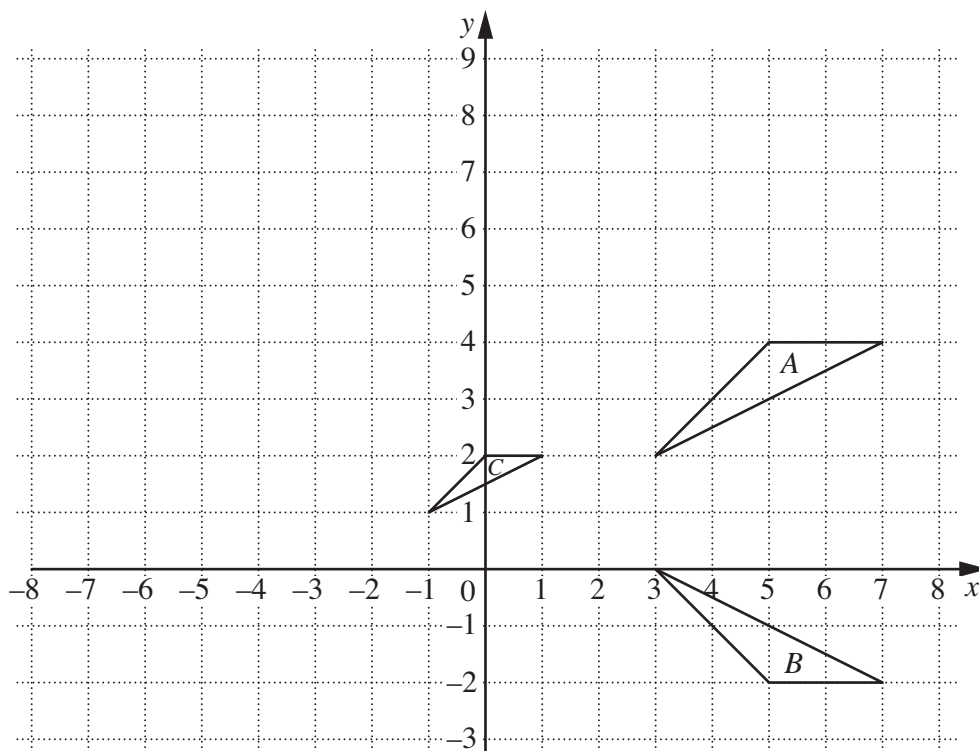

(i) Describe fully the **single** transformation that maps triangle A onto triangle B.

Answer [2]

(ii) Describe fully the **single** transformation that maps triangle A onto triangle C.

Answer [2]

(iii) Another transformation is represented by the matrix **P**, where $\mathbf{P} = \begin{pmatrix} 0 & -1 \\ 1 & 0 \end{pmatrix}$. This transformation maps triangle A onto triangle D.

Find the vertices of triangle D.

Answer (.....,) (.....,) (.....,) [2]

(iv) Describe fully the **single** transformation represented by the matrix **P**.

Answer [2]

- 9 The table below shows some of the values of x and the corresponding values of y for

$$y = (2x - 3)(x + 2).$$

*Do not
write in this
margin*

x	-3	-2	-1	0	1	2	3
y	9	0			-3	4	15

- (a) Complete the table.

[1]

- (b) On the axes below, plot the points from the table and join them with a smooth curve.

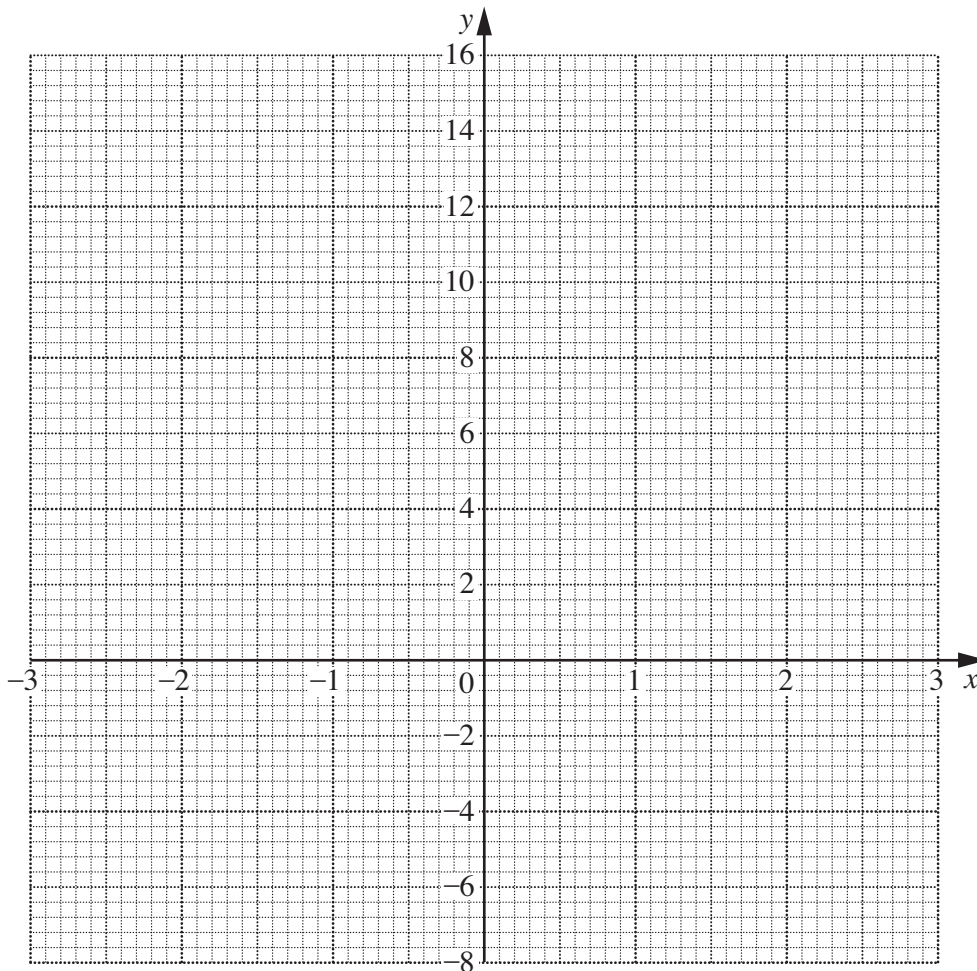

[2]

(c) Use your graph to

(i) solve the equation $(2x - 3)(x + 2) = 2$,

Answer [1]

(ii) find the minimum value of y ,

Answer [1]

(iii) find the gradient of the curve at $(2, 4)$.

Answer [2]

(d) (i) Show that the x -coordinates of the points where $y = (2x - 3)(x + 2)$ and $y = 1 - 2x$ would intersect are the solutions of the equation

$$2x^2 + 3x - 7 = 0.$$

[1]

(ii) Solve **algebraically** the equation $2x^2 + 3x - 7 = 0$, giving each answer correct to 2 decimal places.

Answer $x = \dots\dots\dots$ or $\dots\dots\dots$ [4]

Do not
write in this
margin

10

Do not write in this margin

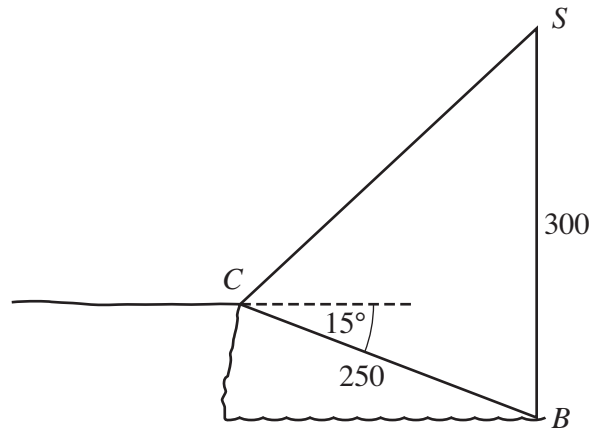

The angle of depression of a buoy, B , from a point, C , on a cliff is 15° .
 The distance BC is 250 m.
 A seagull, S , hovers so that it is vertically above B and $SB = 300$ m.

(a) (i) Find \hat{SBC} .

Answer [1]

(ii) Find SC .

Answer m [3]

(iii) Find the angle of elevation of S from C .

Answer [3]

(b)

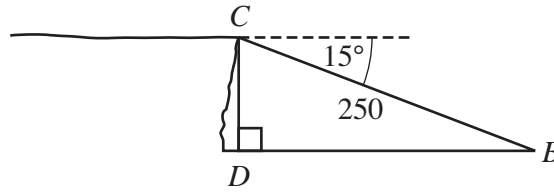

Do not
write in this
margin

D is a marker at sea level vertically below C and due west of B .

(i) Find DB .

Answerm [2]

(ii) M is a marker at sea level 200 m from B and $\hat{DBM} = 30^\circ$.

Find the area of triangle DBM .

Answer m² [2]

(iii) N is a marker at sea level due south of B and $DN = 450$ m.
A boat sails on a circular course through D , B and N .

Write down the radius of the circle.

Answerm [1]

11 [Volume of a cone = $\frac{1}{3} \pi r^2 h$]

Do not
write in this
margin

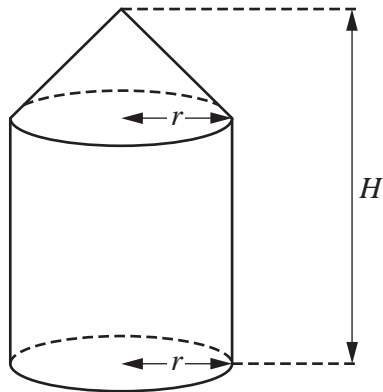

The solid above consists of a cone with base radius r centimetres on top of a cylinder of radius r centimetres.

The height of the cylinder is twice the height of the cone.

The total height of the solid is H centimetres.

- (a) Find an expression, in terms of π , r and H , for the volume of the solid.
Give your answer in its simplest form.

Answer [3]

- (b) It is given that $r = 10$ and the height of the **cone** is 15 cm.

- (i) Show that the slant height of the cone is 18.0 cm, correct to one decimal place.

[2]

- (ii) Find the circumference of the base of the cone.

Do not write in this margin

Answer cm [2]

- (iii) The curved surface area of the cone can be made into the shape of a sector of a circle with angle θ° .

Show that θ is 200, correct to the nearest integer.

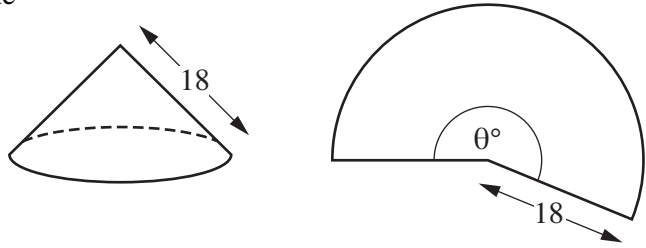

[2]

- (iv) Hence, or otherwise, find the **total** surface area of the solid.

Answercm² [3]

- 12 The time taken by each of 320 students taking a Physics test was recorded. The following table shows a distribution of their times.

Time (m minutes)	$60 < m \leq 70$	$70 < m \leq 80$	$80 < m \leq 90$	$90 < m \leq 100$	$100 < m \leq 110$	$110 < m \leq 120$
Frequency	24	92	104	68	24	8

- (a) Complete the cumulative frequency table below.

Time (m minutes)	$m \leq 60$	$m \leq 70$	$m \leq 80$	$m \leq 90$	$m \leq 100$	$m \leq 110$	$m \leq 120$
Cumulative frequency	0	24	116				

[1]

- (b) For this part of the question use the graph paper opposite.

- (i) Using a scale of 2 cm to represent 10 minutes, draw a horizontal m -axis for $60 \leq m \leq 120$.
Using a scale of 1 cm to represent 20 students, draw a vertical axis for cumulative frequencies from 0 to 320.
On your axes, draw a smooth cumulative frequency curve to illustrate the information. [3]

- (ii) Use your graph to estimate

- (a) the median,

Answer minutes [1]

- (b) the interquartile range,

Answer minutes [2]

- (c) the percentage of students who took at least 95 minutes to complete the test.

Answer [2]

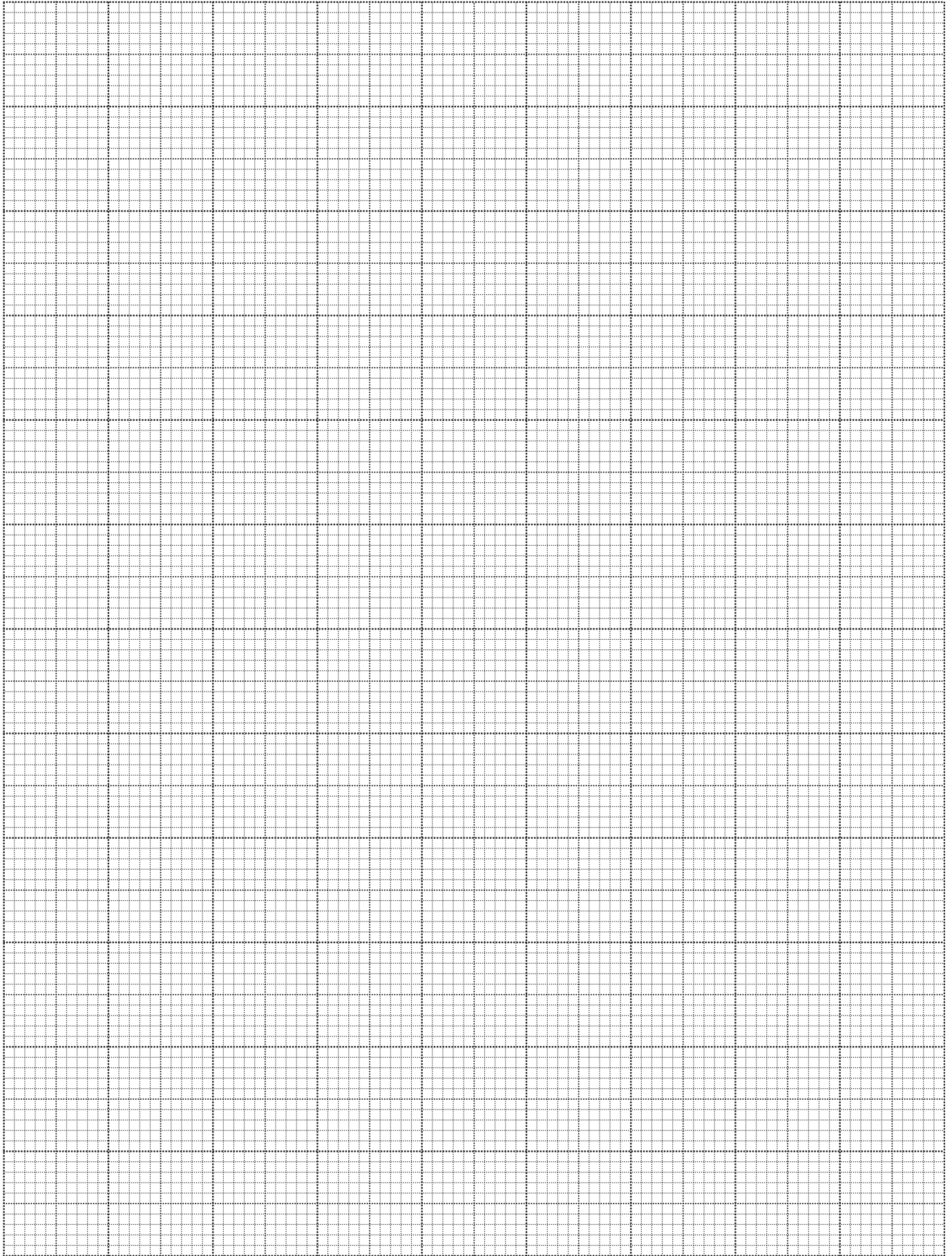

Please turn over for the rest of this question.

- (iii) A group of 300 students of similar ability took an equivalent test the previous year. The following graph shows a distribution of their times.

Do not write in this margin

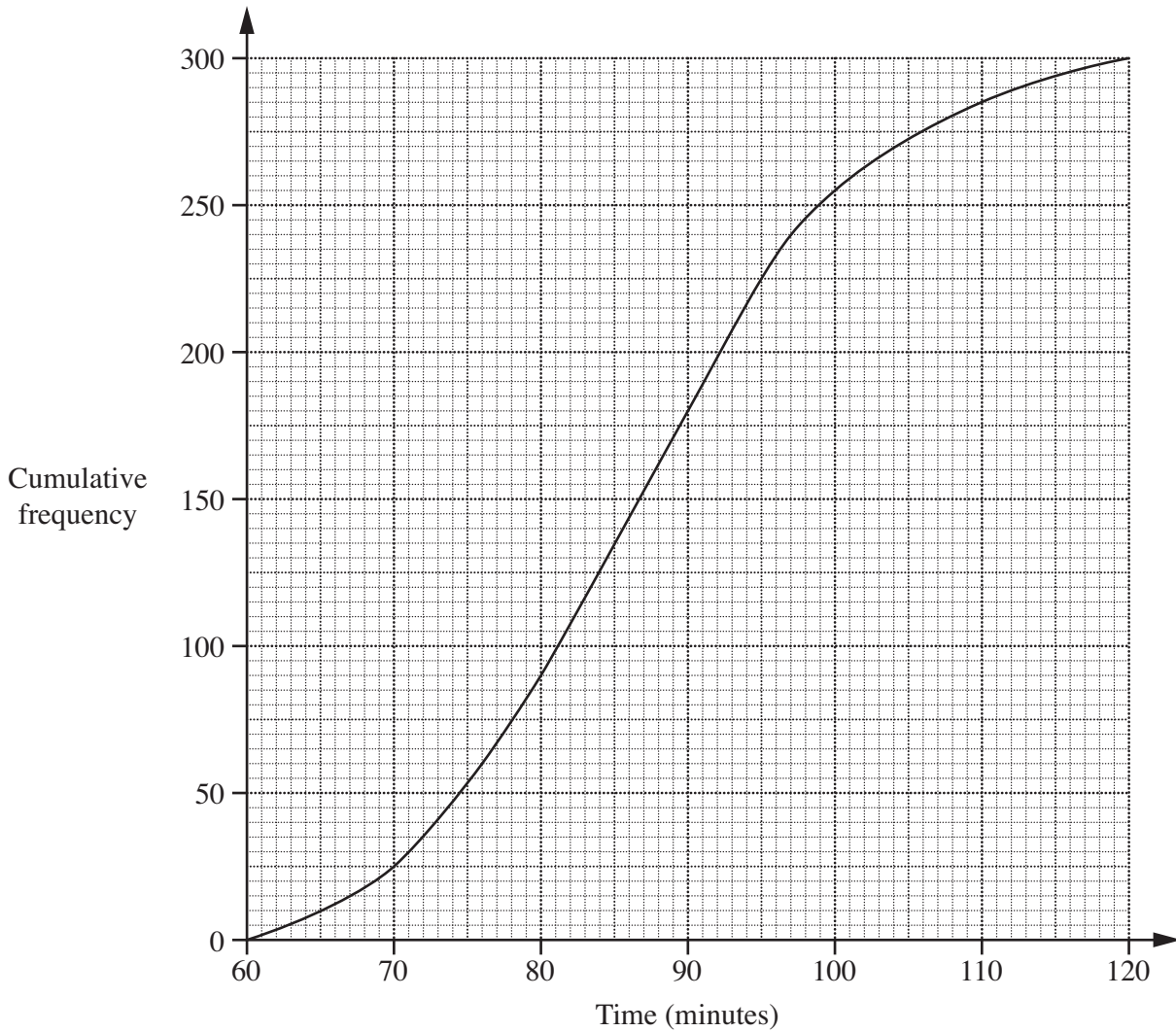

- (a) Find the 20th percentile.

Answer minutes [1]

- (b) Find the percentage of students who took at least 95 minutes to complete the test.

Answer [1]

- (c) Hence make a comparison between the two tests.

Answer
 [1]

Permission to reproduce items where third-party owned material protected by copyright is included has been sought and cleared where possible. Every reasonable effort has been made by the publisher (UCLES) to trace copyright holders, but if any items requiring clearance have unwittingly been included, the publisher will be pleased to make amends at the earliest possible opportunity.

University of Cambridge International Examinations is part of the Cambridge Assessment Group. Cambridge Assessment is the brand name of University of Cambridge Local Examinations Syndicate (UCLES), which is itself a department of the University of Cambridge.