



UNIVERSITY OF CAMBRIDGE INTERNATIONAL EXAMINATIONS  
General Certificate of Education Ordinary Level

CANDIDATE  
NAME

CENTRE  
NUMBER

--	--	--	--	--

CANDIDATE  
NUMBER

--	--	--	--



**MATHEMATICS (SYLLABUS D)**

**4024/01**

Paper 1

**October/November 2007**

**2 hours**

Candidates answer on the Question Paper.

Additional Materials: Geometrical instruments

**READ THESE INSTRUCTIONS FIRST**

Write your Centre number, candidate number and name on all the work you hand in.

Write in dark blue or black pen.

You may use a pencil for any diagrams or graphs.

Do not use staples, paper clips, highlighters, glue or correction fluid.

DO **NOT** WRITE IN ANY BARCODES.

Answer **all** questions.

If working is needed for any question it must be shown in the space below that question.

Omission of essential working will result in loss of marks.

The number of marks is given in brackets [ ] at the end of each question or part question.

The total of the marks for this paper is 80.

**NEITHER ELECTRONIC CALCULATORS NOR MATHEMATICAL TABLES MAY BE USED IN THIS PAPER.**

At the end of the examination, fasten all your work securely together.

**For Examiner's Use**

--

This document consists of **16** printed pages.



**NEITHER ELECTRONIC CALCULATORS NOR MATHEMATICAL TABLES  
MAY BE USED IN THIS PAPER.**

- 1 (a) Express  $22\frac{1}{2}\%$  as a fraction in its lowest terms.  
(b) Evaluate  $0.9 \times 0.02$ .

Answer (a) ..... [1]

(b) .....[1]

---

- 2 Express as a single fraction in its lowest terms

(a)  $3\frac{5}{9} - 2\frac{2}{3}$ ,

(b)  $\frac{3}{8} \div 2\frac{1}{4}$ .

Answer (a) .....[1]

(b) .....[1]

---

- 3 (a) Add 620 grams to 3.7 kilograms.  
Give your answer in kilograms.

Answer (a) .....kg [1]

- (b) Write the following numbers in order of size, starting with the smallest.

$3^1$      $3^{-1}$      $(-1)^3$      $3^0$

Answer (b) ..... , ..... , ..... , ..... [1]  
*smallest*

---

- 4** In the diagram, the circle, centre  $O$ , passes through  $A$ ,  $B$  and  $C$ .  
 $AC$  is a diameter of the circle and the line  $TAS$  is the tangent at  $A$ .  
 $\angle ACB = 34^\circ$ ,  $TA = 3$  cm and  $TC = 5$  cm.

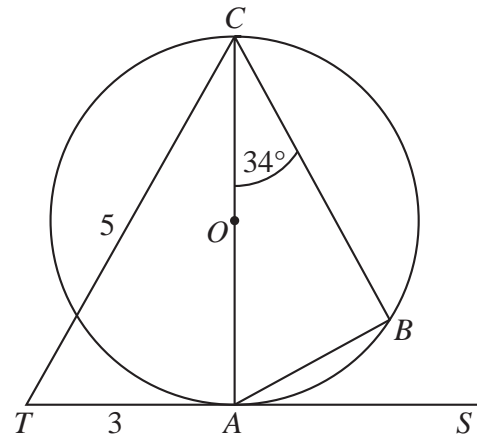

- (a) Find  $\angle BAC$ .  
 (b) Calculate the radius of the circle.

Answer (a)  $\angle BAC = \dots\dots\dots$ [1]

(b)  $\dots\dots\dots$ cm [1]

- 5** (a) The rate of exchange between dollars and euros was \$0.8 to 1 euro.  
 Calculate the number of euros received in exchange for \$300.  
 (b) Find the simple interest on \$450 for 18 months at 4% per year.

Answer (a)  $\dots\dots\dots$ [1]

(b) \$  $\dots\dots\dots$ [1]

**6** It is given that  $f(x) = \frac{3-x}{2}$ .

Find

- (a)  $f(-9)$ ,  
 (b)  $f^{-1}(x)$ .

Answer (a)  $\dots\dots\dots$ [1]

(b)  $f^{-1}(x) = \dots\dots\dots$ [1]

- 7 In an experiment, the heights of some plants were measured.  
The table below summarises the results.

Height ( $h$ cm)	$2 < h \leq 3$	$3 < h \leq 4$	$4 < h \leq 5$	$5 < h \leq 8$
Frequency	15	25	20	15

Complete the histogram which represents this information.

Answer

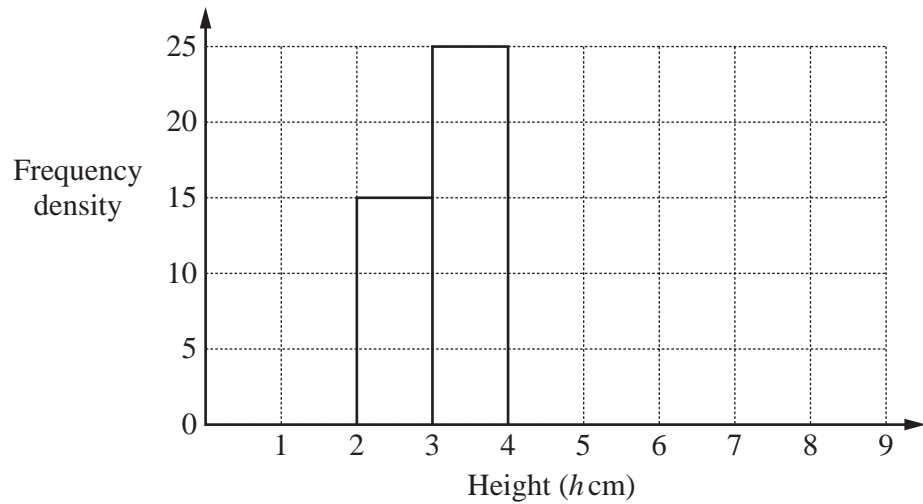

[2]

- 8 The shaded region **inside** the triangle  $ABC$  is defined by three inequalities.

One of these is  $x + y < 5\frac{1}{2}$ .

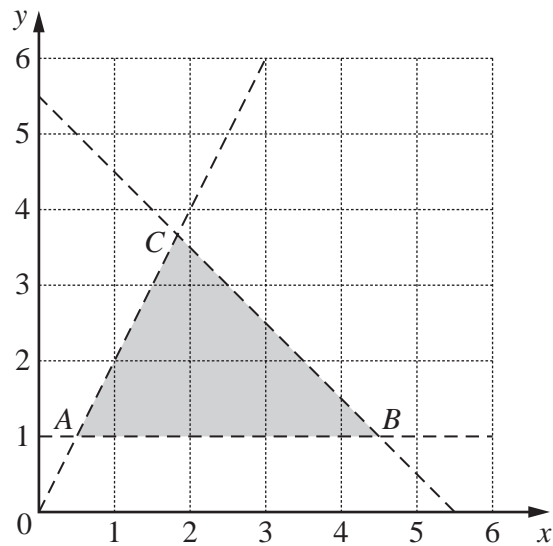

- (a) Write down the other two inequalities.

Answer (a) .....  
.....[2]

- (b) How many points, with integer coordinates, lie in the shaded region?

Answer (b) .....[1]

- 9 (a) Express, in set notation, as simply as possible, the subset shaded in the Venn diagram.

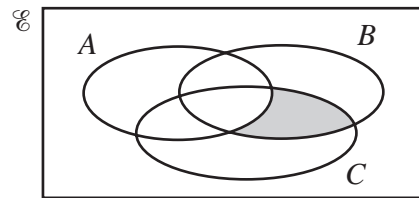

Answer (a) .....[1]

- (b) It is given that  $n(U) = 40$ ,  $n(P) = 18$ ,  $n(Q) = 20$  and  $n(P \cap Q) = 7$ .

Find

- (i)  $n(P \cup Q)$ ,  
(ii)  $n(P' \cap Q')$ .

Answer (b)(i) .....[1]

(ii) .....[1]

---

10  $A = \begin{pmatrix} 4 & -1 \\ 3 & 0 \end{pmatrix}$   $B = \begin{pmatrix} 0 & 1 \\ -3 & 4 \end{pmatrix}$

Find

- (a)  $2A - B$ ,  
(b)  $AB$ ,  
(c)  $A^{-1}$ .

Answer (a)  $\begin{pmatrix} & \\ & \end{pmatrix}$  [1]

(b)  $\begin{pmatrix} & \\ & \end{pmatrix}$  [1]

(c)  $\begin{pmatrix} & \\ & \end{pmatrix}$  [1]

**11** The mass of a marble is given as 5.4 grams, correct to the nearest tenth of a gram.  
The mass of a box is given as 85 grams, correct to the nearest 5 grams.

(a) Complete the table in the answer space.

(b) Find the lower bound for the total mass of the box and 20 identical marbles.

Answer (a)

	Lower bound	Upper bound
Mass of 1 marble	..... g	..... g
Mass of the box	..... g	..... g

[2]

(b) .....g [1]

**12** (a) When an object is falling, the air resistance varies as the square of the speed.  
At a certain speed, the resistance is 30 newtons.  
What is the resistance at twice this speed?

(b)  $y$  is inversely proportional to  $x$ .  
Given that  $y = 6$  when  $x = 4$ , find the value of  $y$  when  $x = 3$ .

Answer (a) ..... newtons [1]

(b)  $y =$  .....[2]

- 13** The diagram shows a container consisting of two cylinders fastened together. The lower cylinder has radius  $r$  centimetres and height  $2h$  centimetres. The upper cylinder has radius  $2r$  centimetres and height  $h$  centimetres. Water was poured into the container at a constant rate. The container was filled in 12 minutes.

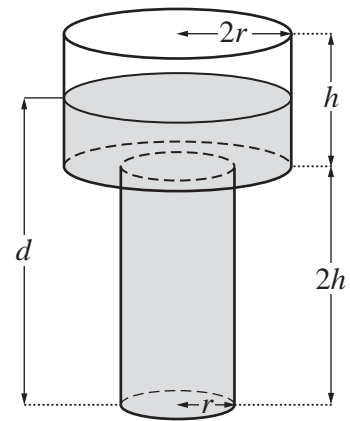

- (a) Calculate the time taken to fill the lower cylinder.

Answer (a) .....minutes [1]

- (b) On the axes in the answer space, draw the graph showing how the depth,  $d$  centimetres, of water, changes during the 12 minutes.

Answer (b)

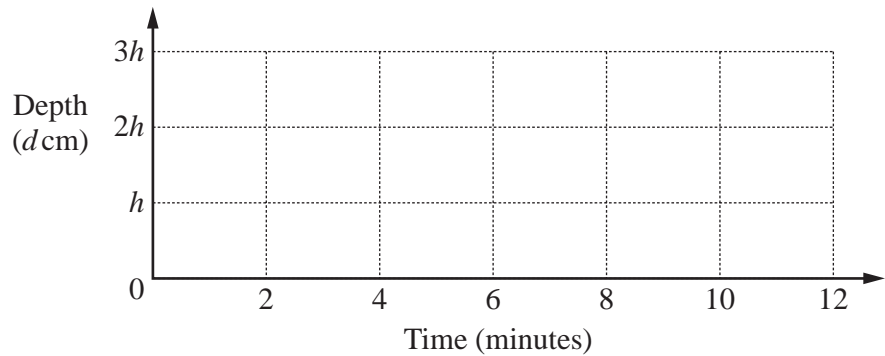

[2]

- 14** Solve the equations

(a)  $\frac{24}{x-4} = 1,$

(b)  $12 - 2(5 - y) = 5y.$

Answer (a)  $x =$  .....[1]

(b)  $y =$  .....[2]

15

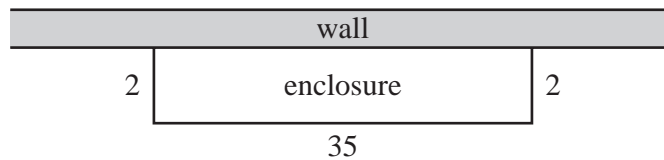

A farmer wishes to build a rectangular enclosure against a straight wall. He has 39 identical fence panels, each 1 metre long. One possible arrangement, which encloses an area of  $70\text{ m}^2$ , is shown in the diagram and recorded in the table below.

Find the length of the enclosure which would contain the largest area. Write down this length and the largest area. Record all your trials in the table. Marks will be awarded for clear, appropriate working.

Width (m)	2				
Length (m)	35				
Area ( $\text{m}^2$ )	70				

Answer Length = ..... m

Area = .....  $\text{m}^2$  [3]



**16** Solve the simultaneous equations

$$\begin{aligned}2x - y &= 16, \\3x + 2y &= 17.\end{aligned}$$

Answer  $x =$  .....

$y =$  .....[3]

**17 (a)** It is given that  $p = 4 \times 10^5$  and  $q = 8 \times 10^6$ .  
Expressing your answers in standard form, find

(i)  $\frac{p}{q}$ ,

(ii)  $\sqrt[3]{q}$ .

Answer (a)(i) .....[1]

(ii) .....[1]

**(b)** The numbers 225 and 540, written as the products of their prime factors, are

$$225 = 3^2 \times 5^2, \quad 540 = 2^2 \times 3^3 \times 5.$$

(i) Write 2250 as the product of its prime factors.

(ii) Find the smallest positive integer value of  $n$  for which  $225n$  is a multiple of 540.

Answer (b)(i) .....[1]

(ii)  $n =$  .....[1]

18

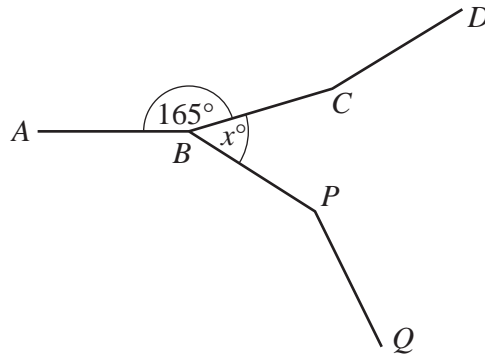

In the diagram,  $ABCD$  is part of a regular polygon.  
Each interior angle is  $165^\circ$ .

- (a) How many sides does this polygon have?
- (b)  $ABPQ$  is part of another regular polygon.  
This polygon has 12 sides.  
Calculate  $x$ .

Answer (a) .....[2]

(b)  $x =$  .....[2]

19 (a) Estimate the value, correct to one significant figure, of  $\frac{4.03^2 \times 29.88}{\sqrt{150}}$ .

Answer (a) .....[2]

(b) Sam ran 100 metres in 12 seconds.  
Calculate his average speed in kilometres per hour.

Answer (b) ..... km/h [2]

---

20 Factorise completely

(a)  $15a^2 + 12a^3$ ,

(b)  $1 - 16b^2$ ,

(c)  $6cx - 3cy - 2dx + dy$ .

Answer (a) .....[1]

(b) .....[1]

(c) .....[2]

- 21** A bag contains 1 red, 1 blue and 3 green balls.  
Two balls are taken from the bag, at random, without replacement.  
The tree diagram that represents these events is drawn below.

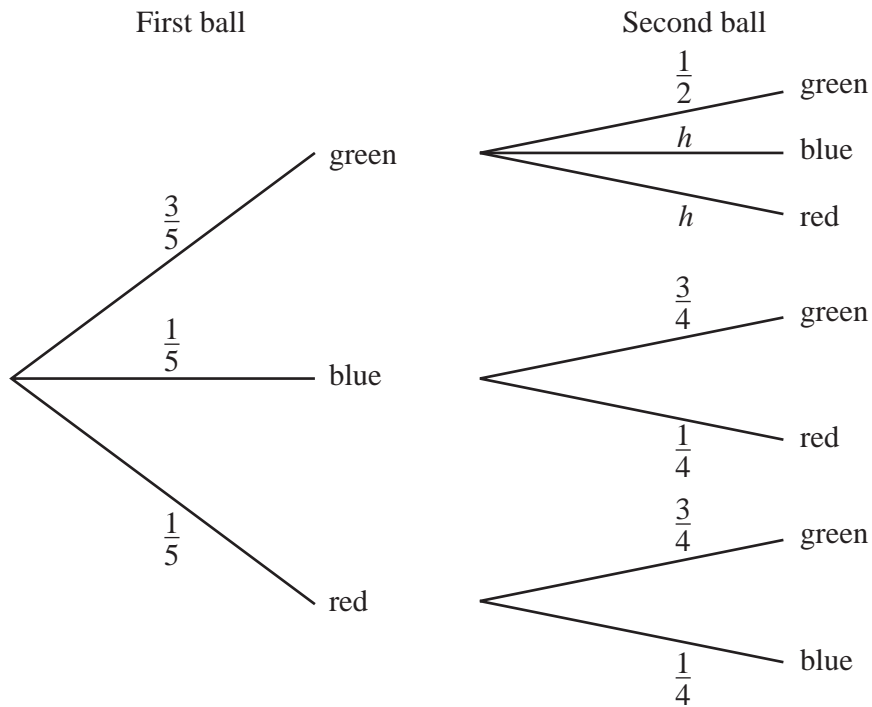

- (a) Write down the value of  $h$ .
- (b) Expressing each answer in its simplest form, calculate the probability that
- (i) both balls are green,
  - (ii) both balls are blue,
  - (iii) neither ball is green.

Answer (a)  $h = \dots\dots\dots$ [1]

(b)(i)  $\dots\dots\dots$ [1]

(ii)  $\dots\dots\dots$ [1]

(iii)  $\dots\dots\dots$ [1]

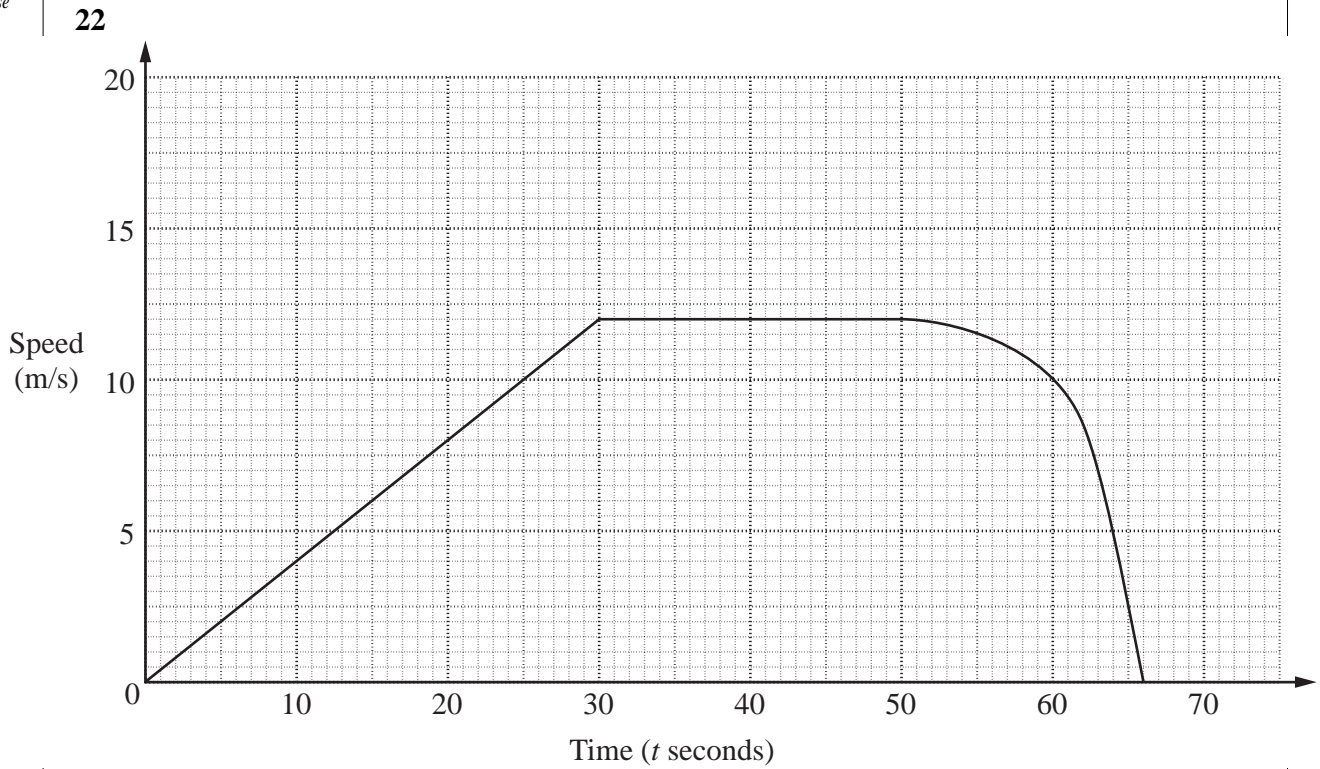

The diagram is the speed-time graph of a cyclist's journey.

- (a) Calculate the time taken to travel the first 300 metres.
- (b) By drawing a tangent, find the retardation of the cyclist when  $t = 55$ .

Answer (a) ..... s [2]

(b) .....  $\text{m/s}^2$  [2]

**23** The foot of a mountain is at sea level.  
The temperature at the foot of the mountain was  $16^{\circ}\text{C}$ .  
The temperature at a height of 3000 m on the mountain was  $-4^{\circ}\text{C}$ .

- (a) Find the difference between these temperatures.
- (b) Given that the temperature fell at a constant rate, find
  - (i) the temperature at a height of 1800 m,
  - (ii) the height at which the temperature was  $0^{\circ}\text{C}$ ,
  - (iii) an expression, in terms of  $x$ , for the temperature, in  $^{\circ}\text{C}$ , at a height of  $x$  metres.

Answer (a) .....  $^{\circ}\text{C}$  [1]

(b)(i) .....  $^{\circ}\text{C}$  [1]

(ii) ..... m [1]

(iii) ..... [2]

- 24 A series of diagrams, using three types of triangle, is shown below.  
The triangles are grey, white or black.

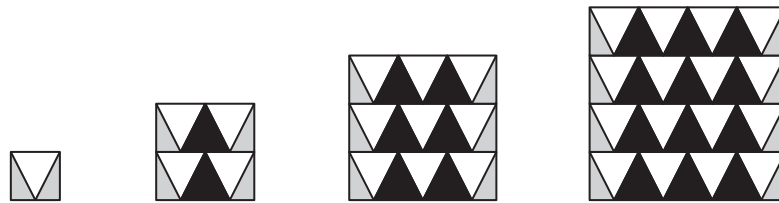

Diagram 1    Diagram 2    Diagram 3    Diagram 4

The table below shows the numbers of each type of triangle used in the diagrams.

Diagram	1	2	3	4		$n$
Grey triangles	2	4	6			$x$
White triangles	1	4	9			$y$
Black triangles	0	2	6			$z$

- (a) Complete the column for Diagram 4. [1]
- (b) By considering the number patterns in the table, find, in terms of  $n$ , expressions for  $x$ ,  $y$  and  $z$ .

Answer (b)  $x = \dots\dots\dots$

$y = \dots\dots\dots$

$z = \dots\dots\dots$  [4]

25 The diagram at the bottom of the page shows a triangle  $ABC$ .

(a) By measuring an angle, find reflex angle  $ACB$ .

Answer (a) .....[1]

(b) The point  $D$  is on the opposite side of  $AC$  to  $B$ .  
 $AD = 6$  cm and  $CD = 9$  cm.  
Construct triangle  $ACD$ .

(c) On the diagram, construct the locus of points, **inside** the quadrilateral  $ABCD$ , which are  
**I** equidistant from  $A$  and  $C$ ,  
**II** 5 cm from the line  $AB$ .

(d) The point  $P$  is inside quadrilateral  $ABCD$ ,  
equidistant from  $A$  and  $C$ ,  
5 cm from the line  $AB$ .

(i) Mark and label the position of  $P$ .

(ii) Measure  $CP$ .

Answer (b)(c)(d)(i)

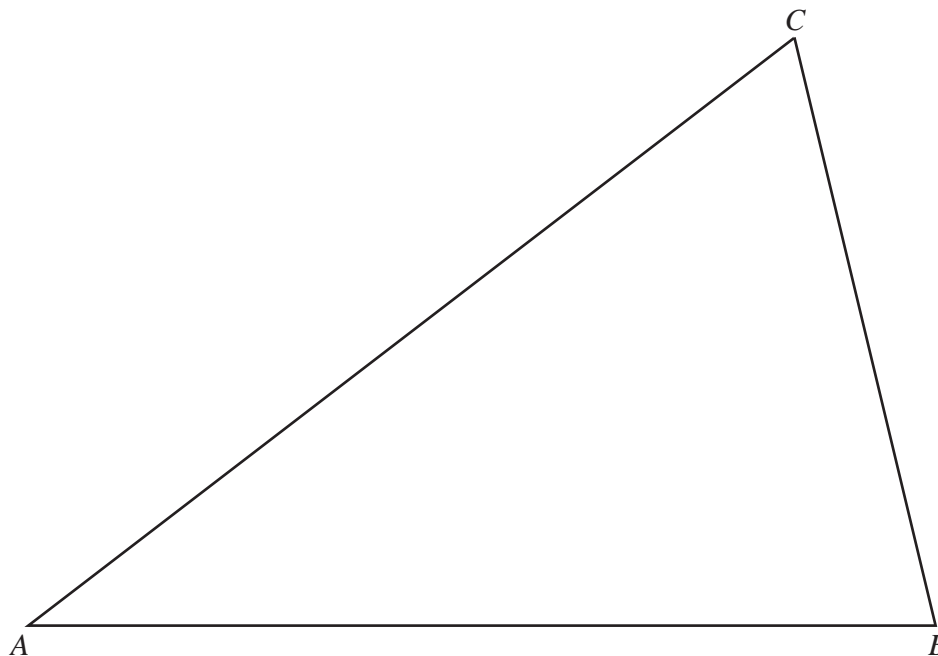

[3]

Answer (d)(ii)  $CP =$  .....cm [1]