

UNIVERSITY OF CAMBRIDGE INTERNATIONAL EXAMINATIONS
General Certificate of Education Ordinary Level

MATHEMATICS (SYLLABUS D)

4024/02

Paper 2

May/June 2005

2 hours 30 minutes

Additional Materials: Answer Booklet/Paper
Electronic calculator
Geometrical instruments
Graph paper (1 sheet)
Mathematical tables (optional)

READ THESE INSTRUCTIONS FIRST

Write your answers and working on the separate Answer Booklet/Paper provided.
Write your Centre number, candidate number and name on all the work you hand in.
Write in dark blue or black pen on both sides of the paper.
You may use a pencil for any diagrams or graphs.
Do not use staples, paper clips, highlighters, glue or correction fluid.

Section A

Answer **all** questions.

Section B

Answer any **four** questions.

At the end of the examination, fasten all your work securely together.
The number of marks is given in brackets [] at the end of each question or part question.

Show all your working on the same page as the rest of the answer.

Omission of essential working will result in loss of marks.

The total of the marks for this paper is 100.

You are expected to use an electronic calculator to evaluate explicit numerical expressions. You may use mathematical tables as well if necessary.

If the degree of accuracy is not specified in the question, and if the answer is not exact, give the answer to three significant figures. Give answers in degrees to one decimal place.

For π , use either your calculator value or 3.142, unless the question requires the answer in terms of π .

This document consists of **11** printed pages and **1** blank page.



Section A [52 marks]Answer **all** the questions in this section.

- 1 (a) Remove the brackets and simplify
- (i) $4(3 - 2p) - 3(1 - p)$, [1]
- (ii) $(3q - r)(q + 2r)$. [2]
- (b) Factorise completely $18t^2 - 2$. [2]
- (c) Given that $y = 18 + 3x^2$,
- (i) find the value of y when $x = -2$, [1]
- (ii) find the values of x when $y = 93$, [2]
- (iii) express x in terms of y . [2]
-

- 2 (a) Two varieties of tea, 'High Blend' and 'Normal Blend', are made by mixing Grade A leaves and Grade B leaves.
- (i) In High Blend, the ratio of the masses of Grade A leaves to Grade B leaves is 3 : 2.
Find the mass of Grade A leaves used in making 250 g of High Blend. [1]
- (ii) 1 kg of Normal Blend is made by using 450 g of Grade A leaves.
Find, **in its simplest form**, the ratio of the masses of Grade A to Grade B leaves in Normal Blend.
Give your answer in the form $m : n$, where m and n are integers. [2]
- (iii) 250 g of High Blend is mixed with 1 kg of Normal Blend.
Calculate the percentage of the mass of this mixture that consists of Grade A leaves. [2]
- (b) During a sale, a shop sold packets of tea for 20% less than the price shown on their labels. Elizabeth and Peter each bought a packet of tea in the sale.
- (i) Elizabeth's packet had a label price of \$4.50.
How much did she pay? [1]
- (ii) Peter paid \$6.20 for his packet.
Calculate the price shown on its label. [2]
-

- 3 (a) In the diagram, $ABCD$ is a parallelogram.
 ADE and BFE are straight lines.

$$AF = BF.$$

$$\hat{A}BF = 54^\circ \text{ and } \hat{C}BF = 57^\circ.$$

Find the value of

- (i) t ,
 (ii) u ,
 (iii) x ,
 (iv) y .

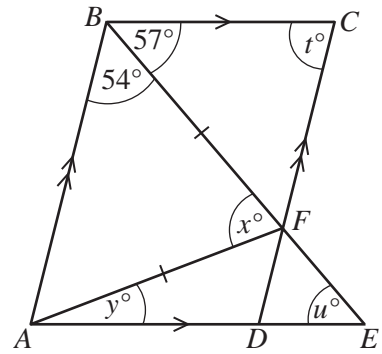

[1]

[1]

[1]

[1]

- (b) This hexagon has rotational symmetry of order 3.

Calculate the value of z .

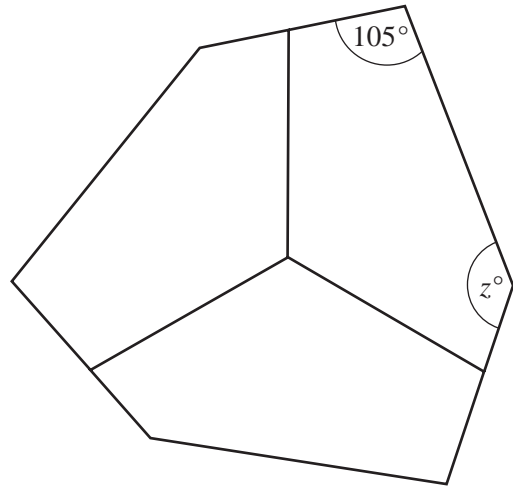

[2]

- (c) In the diagram, triangle PQR
 is similar to triangle PSQ .
 $\hat{P}QR = \hat{P}SQ$.

$$PQ = 18 \text{ cm, } QR = 14 \text{ cm and } QS = 21 \text{ cm.}$$

Calculate the length of

- (i) PR ,
 (ii) RS .

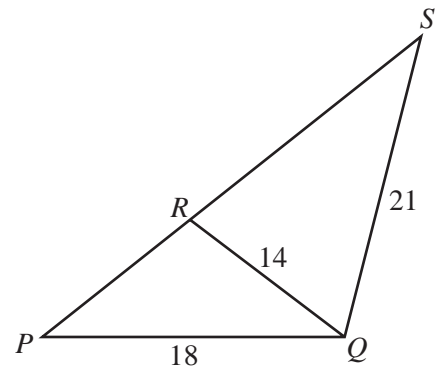

[1]

[2]

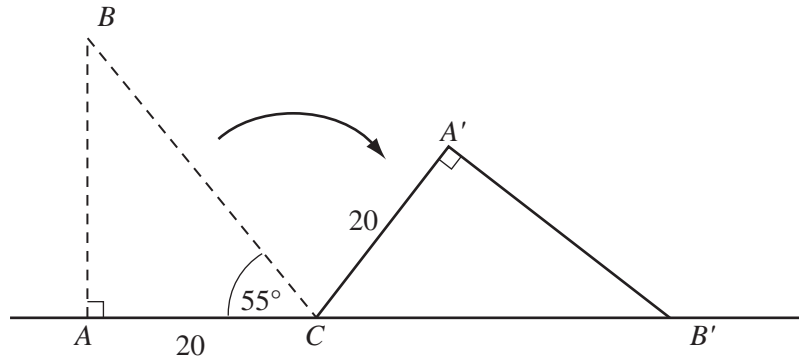

In triangle ABC , $\hat{B}AC = 90^\circ$, $\hat{B}CA = 55^\circ$ and $AC = 20$ cm.

The triangle initially stood with AC on a horizontal surface.

It was then rotated about the point C onto triangle $A'B'C$, where ACB' is a straight line.

(a) Calculate

- (i) the length of BC , [2]
- (ii) the distance AB' , [1]
- (iii) the height of A' above CB' . [2]

(b) Describe **fully** the path which the point A followed under this rotation. [2]

(c) Calculate the length of the path which the point A followed under this rotation. [2]

- 5 (a) Sweet packets contain sweets of different colours.
The number of yellow sweets in each of 25 packets was recorded.
The table below shows the results.

Number of yellow sweets	0	1	2	3	4	5
Frequency	8	5	5	4	2	1

For this distribution,

- (i) write down the mode, [1]
(ii) write down the median, [1]
(iii) calculate the mean. [2]
- (b) A bag contained 5 Red and 2 Blue beads.
Chris took 3 beads, at random, and without replacement, from the bag.
The probability tree shows the possible outcomes and their probabilities.

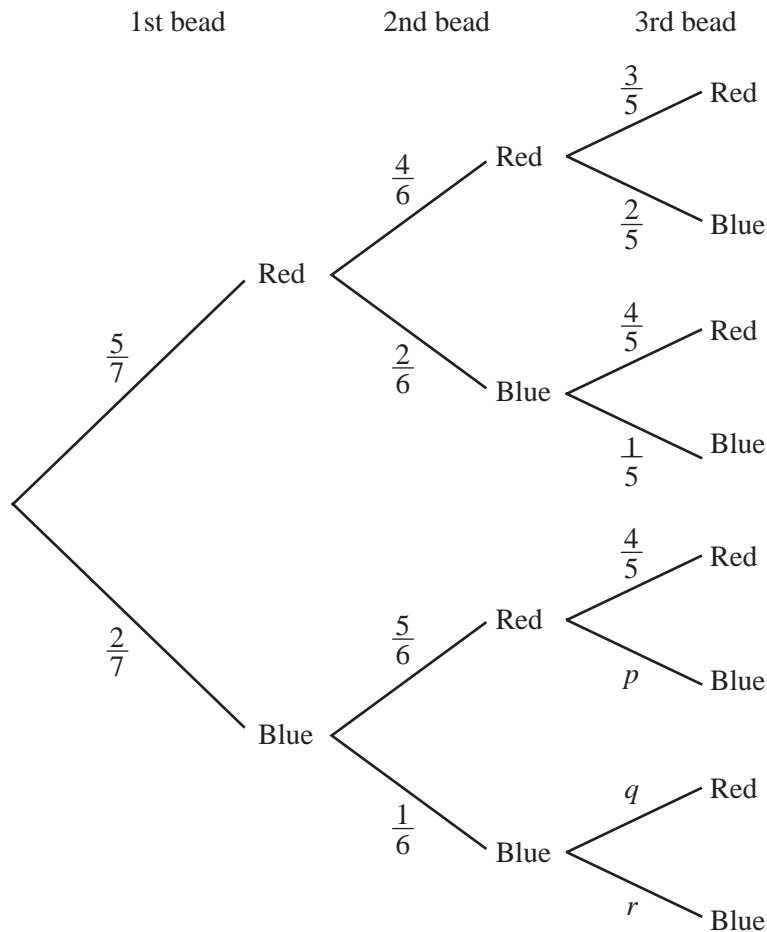

- (i) Write down the values of p , q and r . [2]
(ii) Expressing each answer as a fraction in its lowest terms, find the probability that
(a) three Red beads were taken, [1]
(b) the first bead was Red, the second Blue and the third Red, [1]
(c) two of the beads were Red and one was Blue. [2]

6 Read these instructions.

- A Choose two **different** digits from 1, 2, 3, 4, 5, 6, 7, 8 and 9.
- B Write down the larger two-digit number which can be formed from the chosen digits.
- C Write down the smaller two-digit number which can be formed from the chosen digits.
- D Subtract the smaller number from the larger and note the result.

Example: A Choose 2 and 8.
 B Larger number is eighty-two (82).
 C Smaller number is twenty-eight (28).
 D Subtract: 82
 -28

 54

 Result = 54

- (a) The digits 3 and 7 are chosen.
 Follow the instructions to find the result. [1]
- (b) Choose three other different pairs of digits.
 Follow the instructions to find the result in each case. [1]
- (c) What do you notice about all these results? [1]
- (d) The digits x and y , where $x > y$, are chosen.

Find expressions, in terms of x and y , for the value of

- (i) the larger number, [1]
 - (ii) the result. [2]
-

Section B [48 marks]

Answer **four** questions in this section.

Each question in this section carries 12 marks.

7 [The volume of a pyramid is $\frac{1}{3} \times \text{base area} \times \text{height}$.]

[The volume of a sphere is $\frac{4}{3}\pi r^3$.]

Morph made several different objects from modelling clay.
He used 500 cm^3 of clay for each object.

(a) He made a square-based cuboid of height 2 cm.

Calculate the length of a side of the square.

[2]

(b) He made a pyramid with a base area of 150 cm^2 .

Calculate the height of the pyramid.

[2]

(c) He made a sphere.

Calculate the radius of the sphere.

[2]

(d) He wrapped the clay around the curved surface
of a hollow cylinder of height 6 cm.

The thickness of the clay was 1.5 cm.

Calculate the radius of the hollow cylinder.

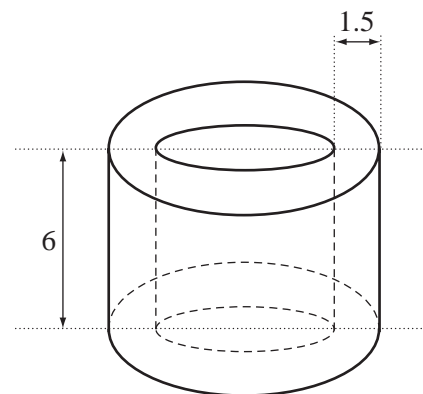

[4]

(e) He made a cone.

Then he cut through the cone, parallel to its
base, to obtain a small cone and a frustum.

The height of the small cone was two-fifths
of the height of the full cone.

Use a property of the volumes of similar
objects to calculate the volume of clay in
the small cone.

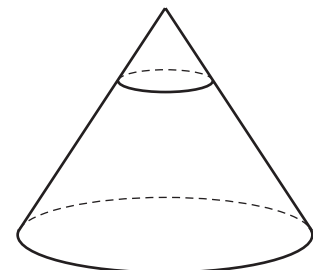

[2]

8 Answer the whole of this question on a sheet of graph paper.

During one day, at a point P in a small harbour, the height of the surface of the sea above the seabed was noted.

The results are shown in the table.

Time (t hours) after 8 a.m.	0	1	2	3	4	5	6	7	8	9
Height (y metres) above the sea-bed	3.8	3.3	2.5	1.8	1.2	1.0	1.2	1.8	2.5	3.3

- (a) Using a scale of 1 cm to represent 1 hour, draw a horizontal t -axis for $0 \leq t \leq 9$.

Using a scale of 2 cm to represent 1 metre, draw a vertical y -axis for $0 \leq y \leq 4$.

On your axes, plot the points given in the table and join them with a smooth curve. [3]

- (b) (i) By drawing a tangent, find the gradient of the curve at the point where $t = 4$. [2]

(ii) Explain the meaning of this gradient. [1]

- (c) On the same day, a straight pole was driven vertically into the seabed at the point P .

Work started at 8 a.m.

The pole was driven in at a constant rate.

The height, y metres, of the top of the pole above the seabed, t hours after 8 a.m., is given by the equation

$$y = 4 - \frac{1}{2}t.$$

- (i) Write down the length of the pole. [1]

(ii) On the same axes as the curve, draw the graph of $y = 4 - \frac{1}{2}t$. [2]

(iii) How many **centimetres** was the top of the pole above the surface of the sea at noon? [2]

(iv) Find the value of t when the top of the pole was level with the surface of the sea. [1]

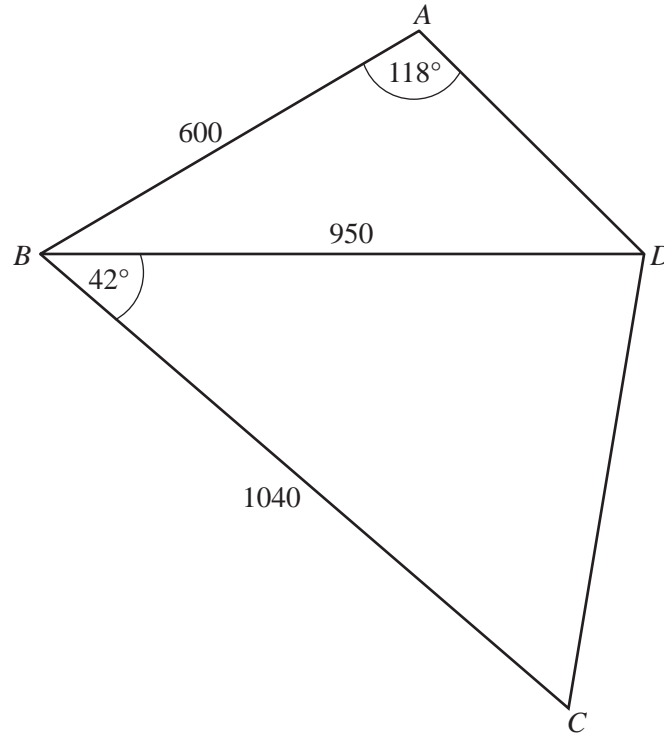

In the diagram, the quadrilateral $ABCD$ represents a level park with a path BD .
 $AB = 600$ m, $BC = 1040$ m, $BD = 950$ m, $\angle CBD = 42^\circ$ and $\angle BAD = 118^\circ$.

(a) Calculate

- (i) angle ABD , [4]
- (ii) the length of CD , [4]
- (iii) the shortest distance from C to BD . [2]

(b) A helicopter flew directly above the path BD at a constant height of 500 m.

Calculate the greatest angle of depression of the point C as seen by a passenger on the helicopter. [2]

10 A route up a mountain is 20 km long.
John followed this route at an average speed of x km/h.

(a) Write down an expression, in terms of x , for the number of hours he took to walk up the mountain. [1]

(b) He came down the mountain by a different route.
The length of this route was 25 km.
His average speed coming down the mountain was 2 km/h greater than his average speed going up the mountain.

Write down an expression, in terms of x , for the number of hours he took to walk down. [1]

(c) It took John $1\frac{1}{2}$ hours less to come down than to go up.

Write down an equation in x , and show that it simplifies to

$$3x^2 + 16x - 80 = 0. \quad [3]$$

(d) Solve the equation $3x^2 + 16x - 80 = 0$, giving both answers correct to 3 decimal places. [4]

(e) Calculate, correct to the nearest minute, the **total** time John took to go up and come down the mountain. [3]

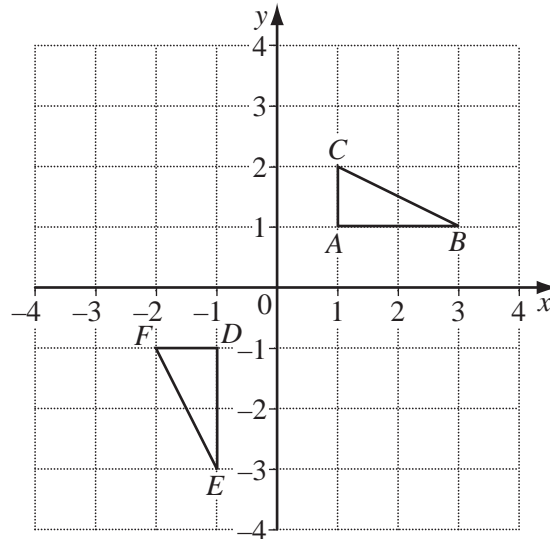

Triangle ABC has vertices $A(1, 1)$, $B(3, 1)$ and $C(1, 2)$.

Triangle DEF has vertices $D(-1, -1)$, $E(-1, -3)$ and $F(-2, -1)$.

The matrix \mathbf{P} represents the **single** transformation, T , that maps triangle ABC onto triangle DEF .

(a) (i) Describe T **fully**. [2]

(ii) Write down the matrix \mathbf{P} . [1]

(b) Another transformation is represented by the matrix \mathbf{Q} , where $\mathbf{Q} = \begin{pmatrix} 0 & -1 \\ 1 & 0 \end{pmatrix}$.

(i) This transformation maps B onto Y .

Find the coordinates of Y . [1]

(ii) This transformation maps K onto C .

Find the coordinates of K . [2]

(iii) Describe, **fully**, the **single** transformation which is represented by \mathbf{Q} . [2]

(iv) The matrix \mathbf{R} is given by $\mathbf{Q} = \mathbf{R}\mathbf{P}$.

By considering the effects of transformations on triangle ABC , or otherwise, find \mathbf{R} . [2]

(c) The point H lies on DC produced, where $\overrightarrow{DH} = \begin{pmatrix} 18 \\ h \end{pmatrix}$.

Calculate

(i) the ratio $DC : DH$, [1]

(ii) the value of h . [1]

BLANK PAGE

Permission to reproduce items where third-party owned material protected by copyright is included has been sought and cleared where possible. Every reasonable effort has been made by the publisher (UCLES) to trace copyright holders, but if any items requiring clearance have unwittingly been included, the publisher will be pleased to make amends at the earliest possible opportunity.

University of Cambridge International Examinations is part of the University of Cambridge Local Examinations Syndicate (UCLES), which is itself a department of the University of Cambridge.