

Centre Number	Candidate Number	Name
---------------	------------------	------

UNIVERSITY OF CAMBRIDGE INTERNATIONAL EXAMINATIONS
General Certificate of Education Ordinary Level

GEOGRAPHY

2217/02

Paper 2

October/November 2006

2 hours 15 minutes

Additional Materials: Ruler
Calculator
Protractor

1:50 000 Survey Map Extract is enclosed with this question paper.

READ THESE INSTRUCTIONS FIRST

Write your Centre number, candidate number and name in the spaces provided.
Write in dark blue or black pen.
You may use a soft pencil for any diagrams, graphs or rough working.
Do not use staples, paper clips, highlighters, glue or correction fluid.

Section A

Answer **all** questions.

Section B

Answer **one** question.

Sketch maps and diagrams should be drawn whenever they serve to illustrate an answer.

At the end of the examination, fasten all your work securely together.
The number of marks is given in brackets [] at the end of each question or part question.

For Examiner's Use	
Q1	
Q2	
Q3	
Q4	
Q5	
Q6	
Q7	
Section B	
Total	

This document consists of **26** printed pages and **2** blank pages.



Section A

Answer **all** questions in this section.

1 Study the map at 1:50 000 scale showing the area around Victoria Falls.

(a) How wide is the River Zambezi at the point where it reaches the main falls?

_____ [1]

(b) How wide is the river in square 7914, which is below the falls?

_____ [1]

(c) How high is the river at the top of the falls? _____ [1]

(d) Give **three** pieces of evidence which suggest that tourism is a feature of Victoria Falls town.

- 1 _____
- 2 _____
- 3 _____ [3]

(e) Describe the landscape that would be seen if you could travel along northing 14 from 740140 to 830140.

_____ [6]

- (f) Describe how the natural vegetation **and** drainage change along easting 70 from 700115 to 700200.
Refer to heights and distances.

[6]

- (g) Give **two** pieces of map evidence to explain the route of the railway from Victoria Falls Station to the northern edge of the map extract.

1 _____

2 _____ [2]

- 2 Study Fig. 1 which shows production of carbon dioxide (CO₂) and energy consumption per person per year for 6 countries. Carbon dioxide is one of the major 'greenhouse gases' which contribute to global warming.

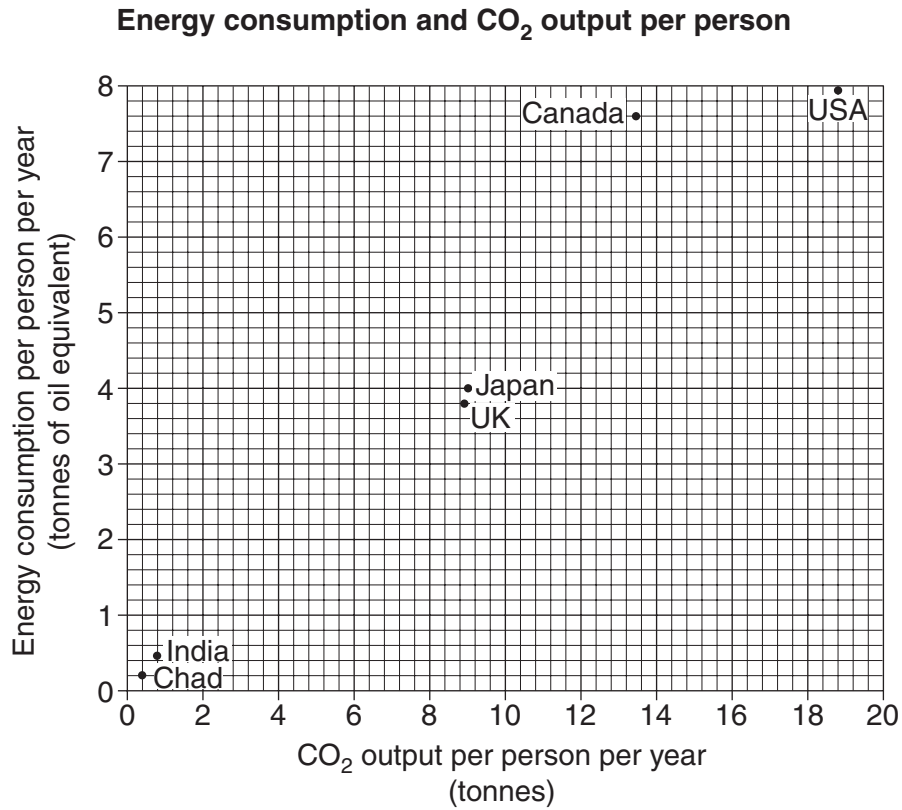

Fig. 1

- (a) On Fig. 1, plot and label the positions for Australia and Brazil using the following figures.

Country	Carbon dioxide (CO ₂) output per person in tonnes	Energy consumption per person in tonnes of oil equivalent
Australia	17	5
Brazil	2	1

[2]

- (b) What is the energy consumption per person in Japan?

[1]

- (c) Describe the pattern shown on the graph. Support your answer with examples from the graph.

[4]

- (d) Suggest **two** reasons for the pattern you have described.

1 _____

2 _____

[2]

3 Study Fig. 2 which shows global energy consumption.

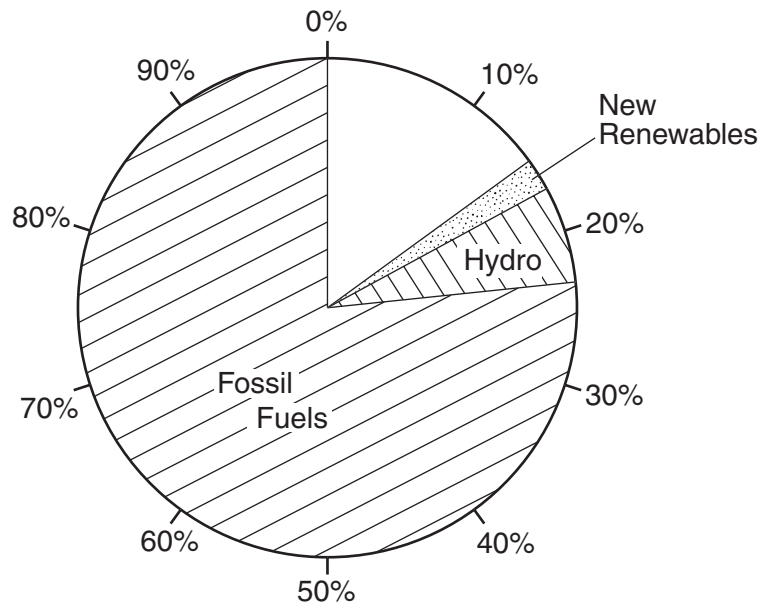

Fig. 2

(a) Using the figures in the table below, complete Fig. 2. [2]

Type of energy	Percentage of global consumption
Nuclear	6%
Biomass – mainly wood	9%

(b) Name **two** examples of fossil fuels.

1 _____ 2 _____ [2]

(c) Which of the types of energy shown on Fig. 2 do **not** give off carbon dioxide?

_____ [2]



Photograph A

Solar cells arranged in panels, like the ones shown here, provide more than a million homes in the developing world with electricity.

- (d) Photograph A shows a panel of solar cells which produce electricity from sunlight. Although at the moment these cells are expensive, why might they be particularly useful to countries in the tropics?

[2]

4 Study Fig. 3 which shows the possible beneficial effects of tourism for LEDCs.

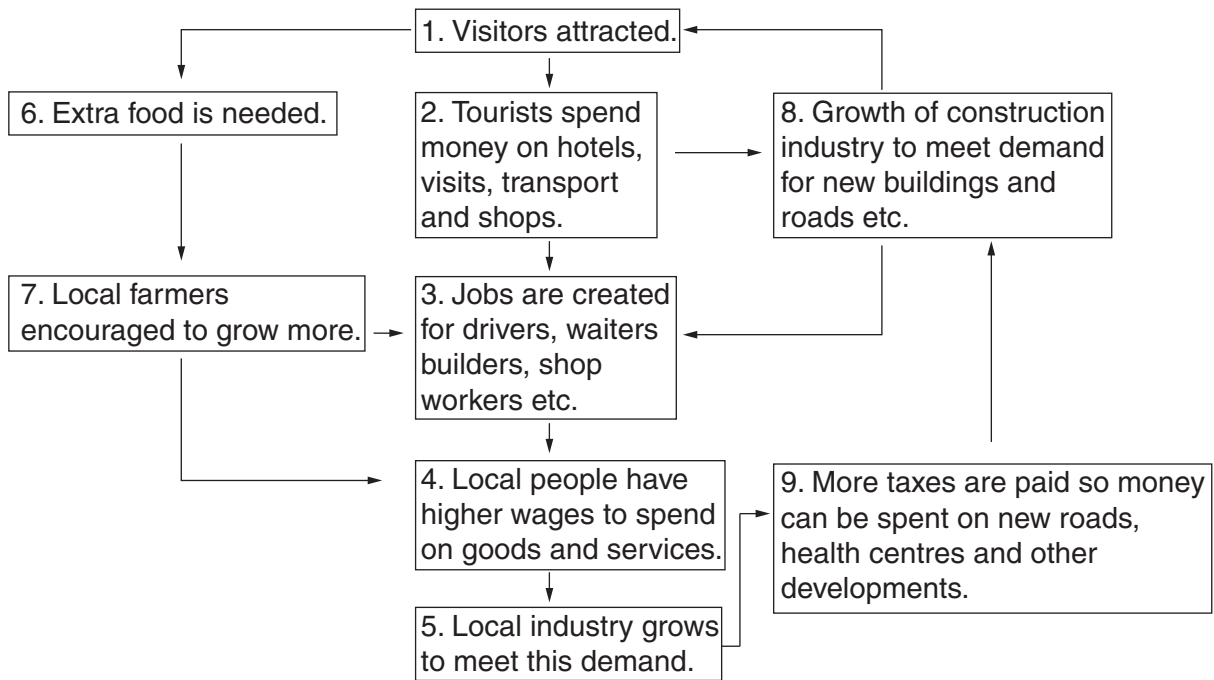

Fig. 3

(a) How does the diagram show that local farmers could benefit from tourism?

[2]

(b) How does the diagram show that the construction industry might benefit?

[2]

(c) Select **one** of the boxes and explain how this development might be a disadvantage to local people.

Box number _____

Disadvantage _____

[2]

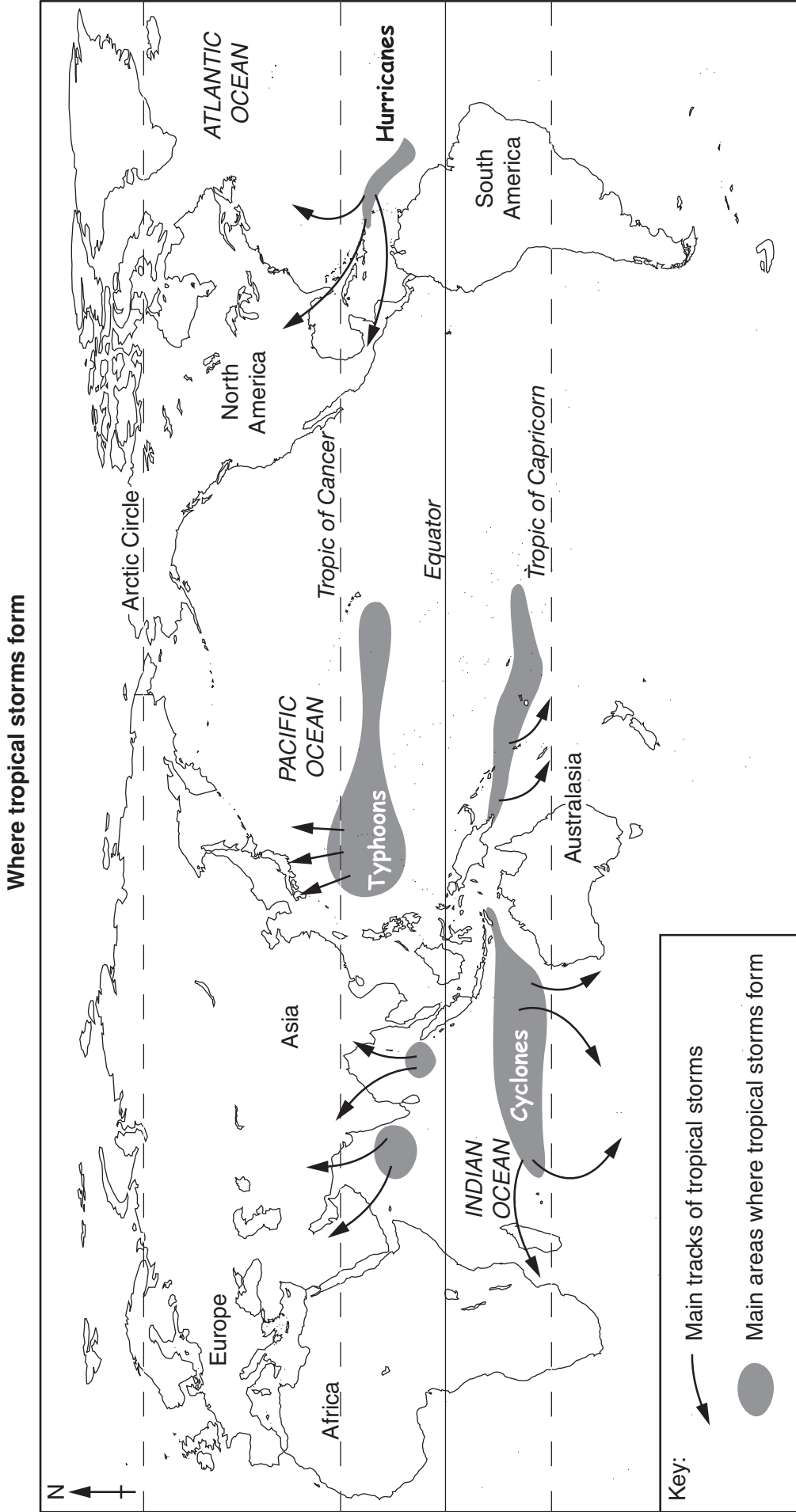

Fig. 4

- 5 Study the world map opposite, Fig. 4, which shows where tropical storms form.

Use information from the map to fill in the blank spaces in the paragraph below.

Tropical storms are also known as _____ and _____ .

They develop over warm _____ where the temperature is 27 °C or more.

Two such areas are _____ and _____ . When the storms

move away from the source area they can grow in intensity and cause great damage. These

storms affect the _____ coast of Africa. [6]

- 6 Read Fig. 5 below. It is a report about an environmental project which takes place at Picalqui in the mountains of Ecuador, a country on the equator in South America.

At Picalqui we have a project to promote environmental education for children and teenagers. It aims to involve them actively in environmental issues and the management of natural resources. Our project works through practical work in the countryside, through links with farming communities and through visits and workshops.

Our work:

- Reafforestation of the area around Picalqui and on communal land
- Establishing tree nurseries
- Establishing vegetable gardens at Picalqui, in nearby schools and in farming communities
- Working with local governments to conserve forest

The programme:

- Sessions on tree management
- Planting at least 12 trees a day
- Workshops on importance of biodiversity
- Visits including camping trips

Fig. 5

- (a) From the report, what is the main type of work this project carries out?

_____ [1]



Photograph B

(b) In Photograph B, how has the project tried to reduce the risk of soil erosion?

[2]

(c) Suggest why this project believes it is important to involve groups of children and teenagers in its work.

[2]

- 7 Fig. 6 shows urban and rural population change in Tanzania, an African country, between 1950 and 2000, with further changes that are expected by 2020.

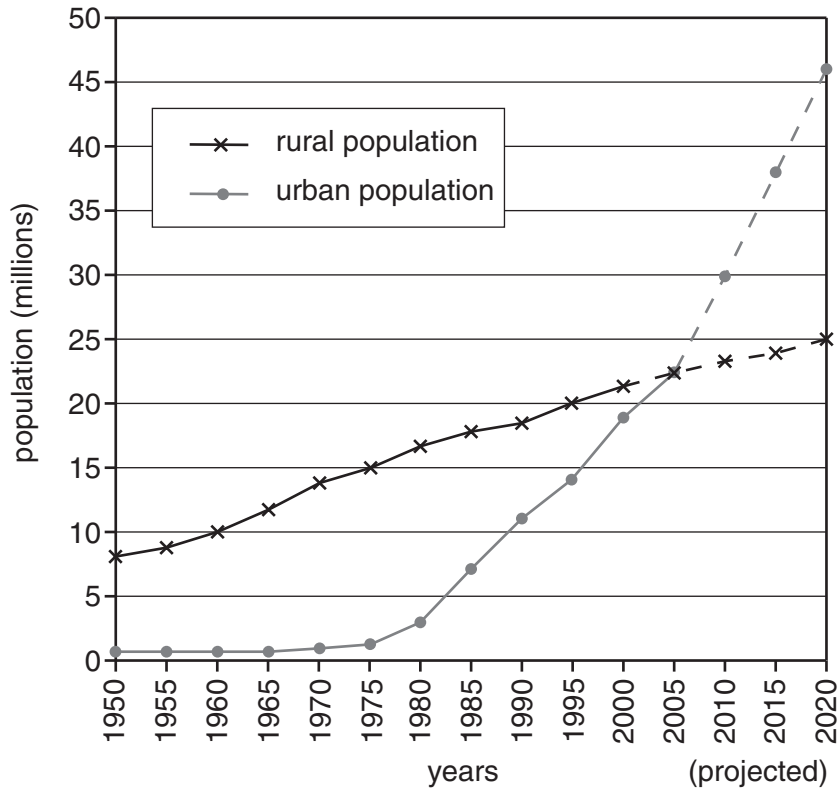

Fig. 6

- (a) Describe the changes to Tanzania's population between 1950 and 2020.

[4]

(b) Suggest **two** reasons which could explain the growth of towns and cities in an LEDC like Tanzania.

Reason 1 _____

Reason 2 _____

_____ [2]

Section B

Answer **one** question in this section.

- 8 Students investigated wave processes along a coastline to find evidence of longshore drift. The area of coastline was used by tourists. Groynes (wooden structures built out into the sea) had been built to stop the movement of beach material. A plan of the coastline area is shown in Fig. 7. The hypothesis for the coursework was

'groynes increase the width and height of the beach by stopping longshore drift'.

Plan of study area

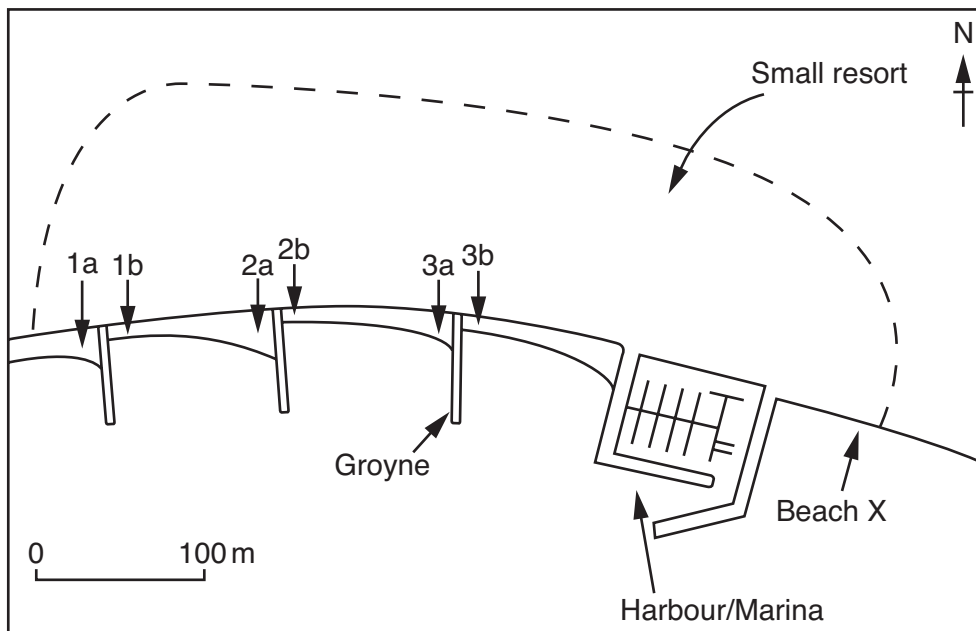

Fig. 7

- (a) (i) Complete the diagram Fig. 8 (A) to show the movement of beach material known as longshore drift. [1]
- (ii) Label the two arrows on Fig. 8 (A) to show
 - the direction of longshore drift,
 - the direction of the prevailing winds.
 [1]
- (iii) Explain the process of longshore drift by completing the text box on Fig. 8(B). [2]

Longshore drift diagram and text box

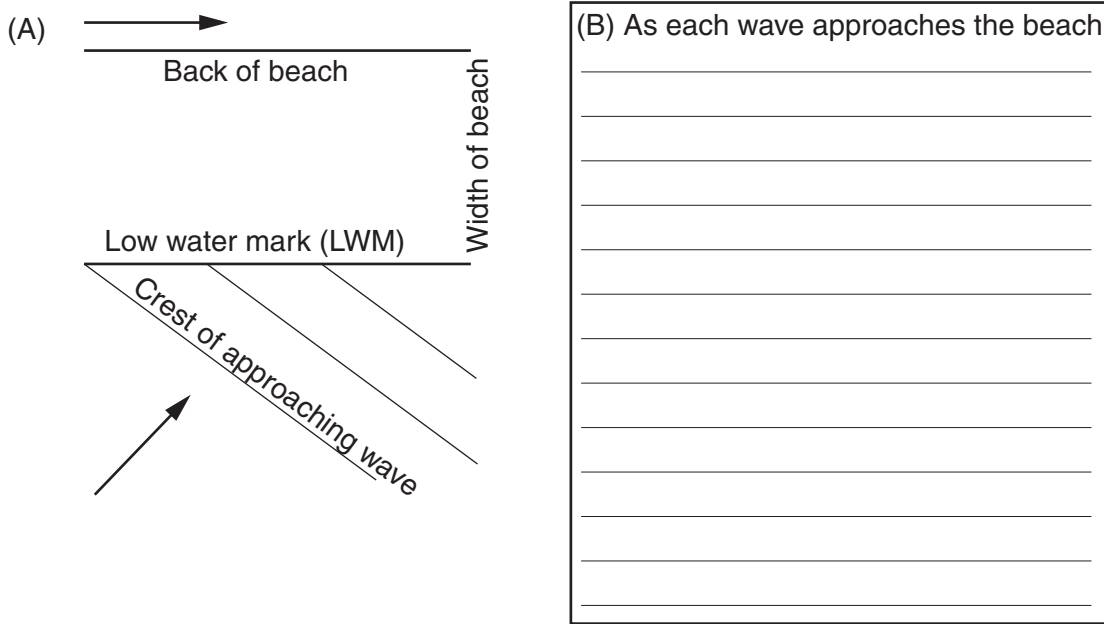

Fig. 8

- (b) (i) The teacher decided to divide the students into three groups. Each group had to complete two beach profiles. Suggest **two** reasons why the teacher made these decisions.

Working in groups

Complete two profiles

[2]

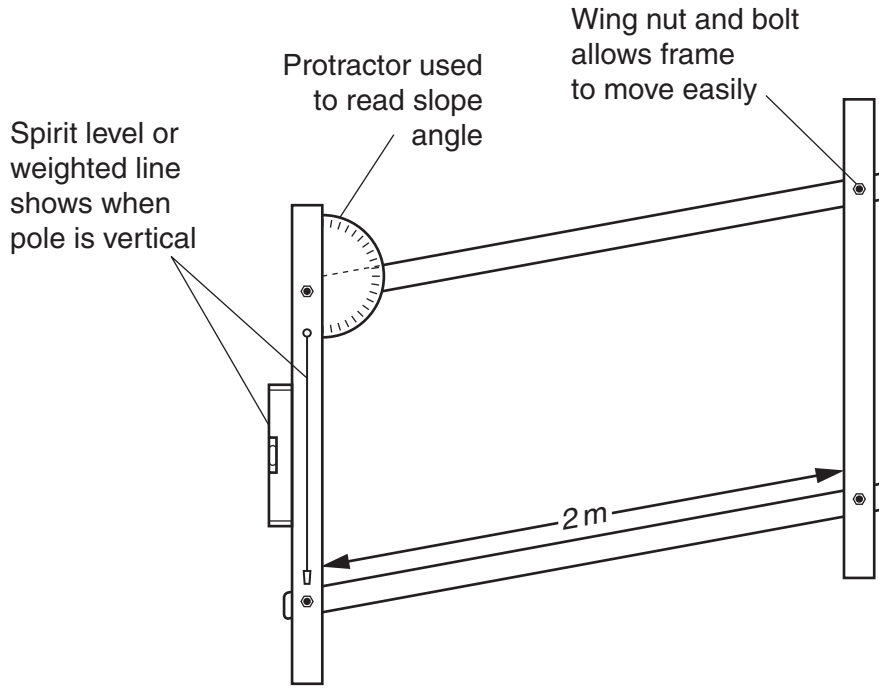

Fig. 9 A pantometer

- (ii) At each site, the students measured the angle of slope of the beach every two metres along a transect line from the low water mark to the back of the beach. The students used a pantometer, as illustrated in Fig. 9, and a long tape measure. Describe in detail how the students measured the beach profile.

[3]

Table 1

Site	Back of beach measurement taken every 2 m								width of beach
	14–16 m	12–14 m	10–12 m	8–10 m	6–8 m	4–6 m	2–4 m	0–2 m	
1a		–	4°	8°	8°	5°	5°	4°	12 m
1b		–	–	–	3°	3°	2°	2°	8 m
2a	10°	3°	3°	7°	7°	3°	8°	5°	16 m
2b		–	–	–	–	5°	2°	2°	6 m
3a		–	3°	8°	7°	4°	5°	4°	11 m
3b		–	–	–	4°	3°	2°	2°	7 m

Beach profile at site 2a

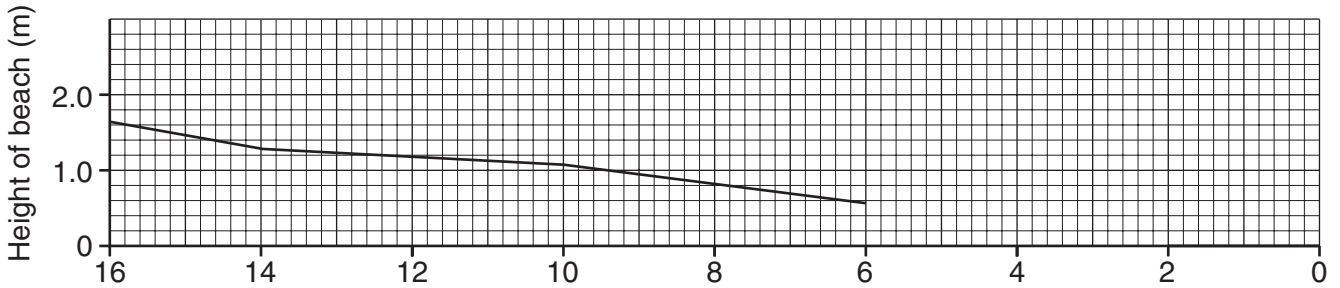

Beach profile at site 2b

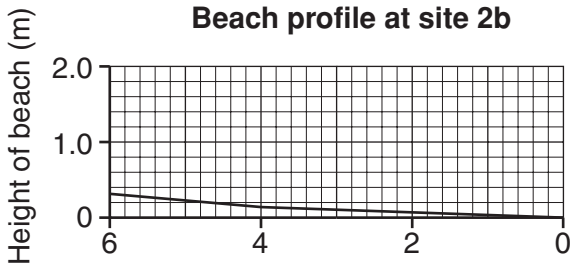

Fig. 10

(c) (i) Study the results of the beach profile measurements in Table 1. Complete the beach profile for site 2a on Fig. 10. [2]

(ii) What is the height difference at the back of the beach between sites 2a and 2b?

_____ [1]

(iii) Describe the differences between the beach profiles at sites 2a and 2b.

_____ [2]

Bar graph of beach widths

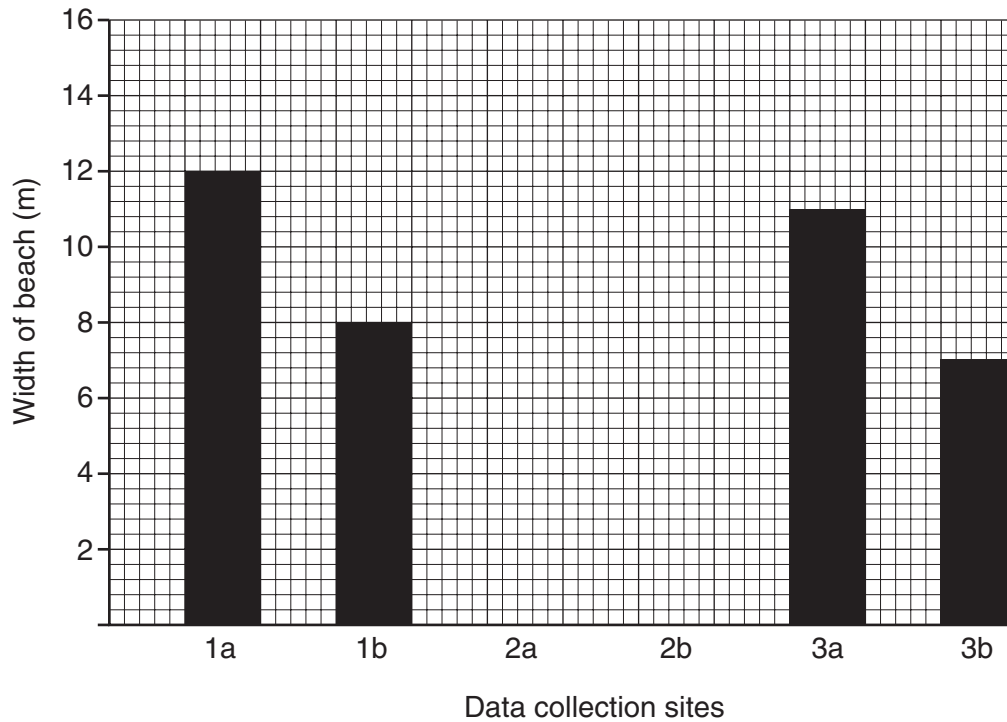

Fig. 11

(d) (i) One student suggested that the widths of the beach at sites 2a and 2b may not be representative of the coastline. Therefore a graph was drawn of all the beach widths. Using the data from Table 1, complete the bar graph for sites 2a and 2b on Fig. 11. [1]

(ii) Calculate the average width of the beaches and plot the average as a line on Fig. 11.

Average width = [2]

(e) Study Fig. 7 and Table 1 again. Describe the overall pattern of slope change shown in Table 1. Suggest reasons for the differences in the beach profiles.

Description _____

Reasons _____

 _____ [4]

(f) (i) Study Fig. 7 again. It shows a harbour/marina has been built along the coastline. Describe the likely height and width of the beach profile at beach X.

[2]

(ii) Suggest how wave processes will be different at beach X compared to the beaches investigated by the students.

[2]

(g) Write a conclusion to this investigation. You should comment on

- the accuracy of the hypothesis,
- data to support your decision,
- limitations of the data.

[5]

[Total: 30 marks]

- 9 Students investigated a cement factory close to their town to find out the impact of the factory on the local people of the town. The students read a local newspaper report, visited the factory and interviewed local residents about the cement factory.

Field sketch and photograph of cement factory

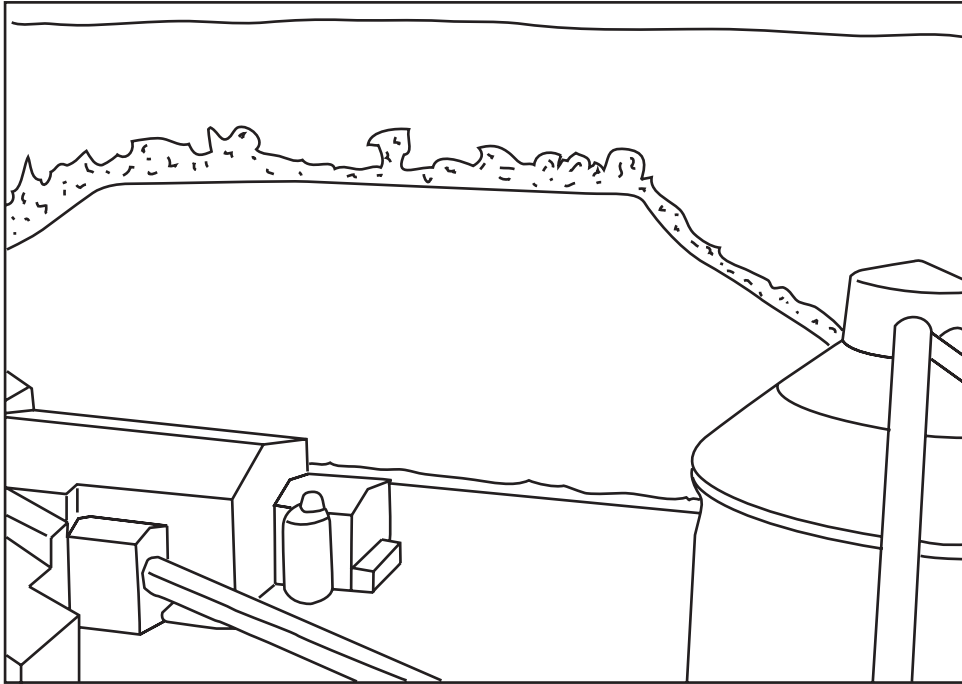

Fig. 12

- (a) Study the photograph. From your observations
- (i) label clearly the working quarry area and the vehicle storage/parking area on the field sketch,
 - (ii) complete the field sketch by showing and labelling the railway line and the local settlement.

- (b) (i) Study the newspaper report (Fig. 13). This is a secondary data source. Describe one advantage and one disadvantage of using information from a secondary source.

Advantage

Disadvantage

[2]

Newspaper report on local cement factory

The large, ugly cement works, which employs lots of local people, produces cement by combining various raw materials. The main component is crushed chalk (which is brought to the factory by underground pipeline as a slurry). Sand is brought into the factory by large trucks and the clay is extracted from the quarry next to the factory. These are all heated in a furnace to over 1000°C by burning coal. The fumes and waste heat from the furnace come out of the tall chimney, which can be seen from a long way away. The fumes have been identified as a source of air pollution and are being constantly monitored by the factory. The final product (the cement) is removed from the factory by road in large trucks and by railway wagons.

Fig. 13

- (ii) State **one** positive impact of the cement factory on the people of the town.

[1]

- (iii) The students underlined key words in the newspaper report to show the inputs of the cement factory. On Fig. 13 ring the keywords which show the processes and add a dotted line under each output.

○ process output

Using this information the students started to produce a systems diagram (Fig. 14). Add the keywords you have identified to the systems diagram (Fig. 14). [3]

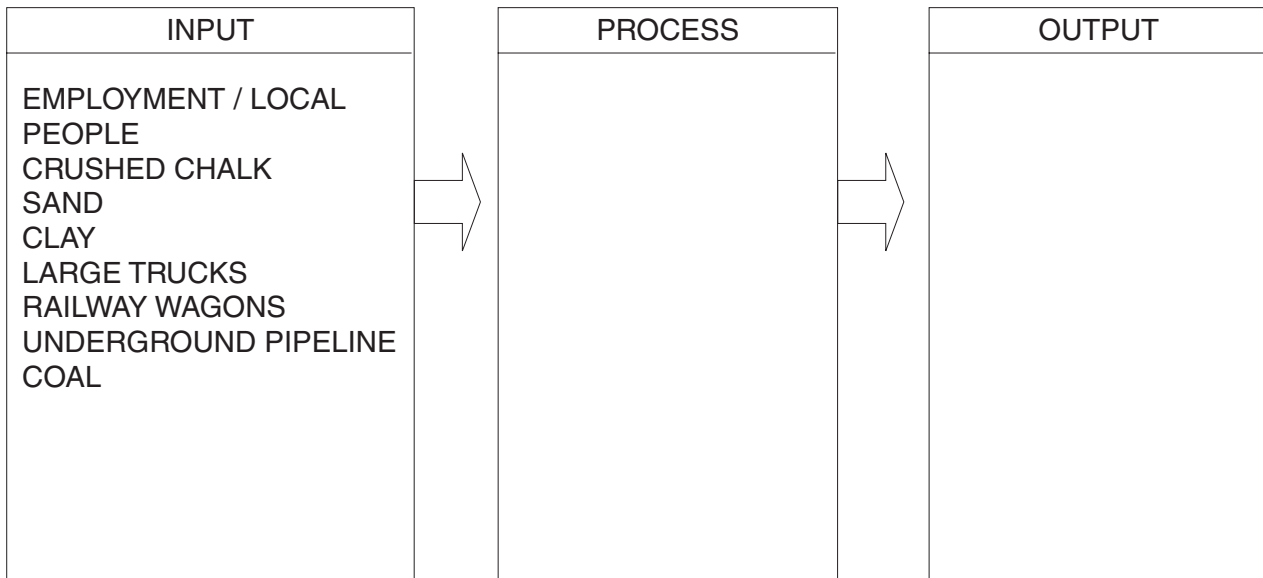
Systems diagram for cement factory**Fig. 14**

- (c) (i) The students interviewed 50 local people by visiting every 5th house in each street of the local settlement. Why did the students choose this systematic sampling method rather than random sampling?

[2]

The interview question was, 'what do you think is the main impact of the cement factory?' The results are shown in Table 2.

Table 2

	Result	Degrees for pie chart
Litter	1	7
Noise from factory	4	29
Noise from trucks	6	43
Noise from railway	8	58
Air pollution	20	144
Visual pollution/ spoils the view	11	79
Total	50	360

Title _____

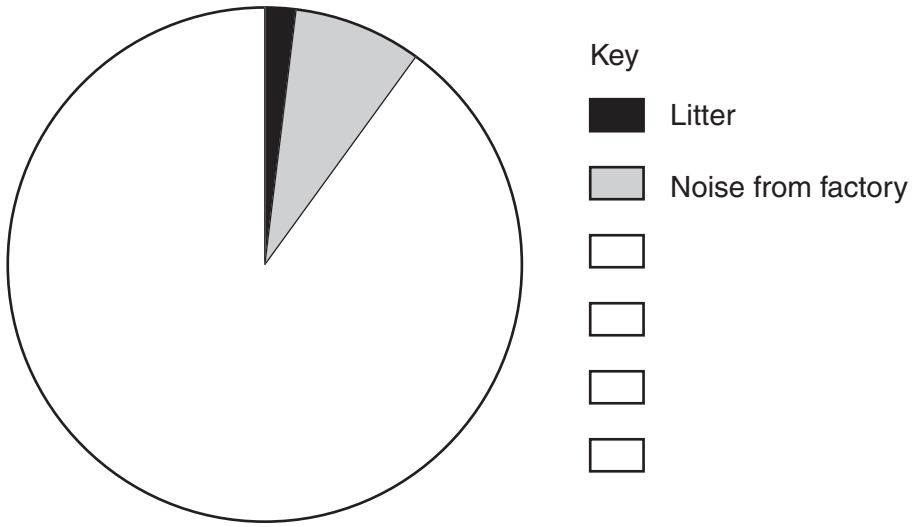

Fig. 15

(ii) Complete the pie chart (divided circle), Fig. 15, to show people's opinions of the impact of the cement factory. You should include a title and finish the key. [5]

(iii) Describe the pattern shown by these results.

_____ [2]

(d) Air pollution can affect people's health and cause environmental problems. Describe some of the problems caused by air pollution.

_____ [3]

- (e) The raw materials and finished product are transported by road, railway and underground pipeline. Stating relevant data, compare the impact of each transport method on the local people. Suggest reasons for your answer.

[3]

- (f) The students decided to extend the investigation to include their own survey of the impact of the cement works on the local environment. Describe in detail possible data collection methods. You should suggest what data the students should collect and how the data could be measured and recorded.

[5]

[Total: 30 marks]

Copyright Acknowledgements:

Question 3 Photograph A © Crispin Hughes, Panos.

Question 6 Photograph B; A. Hudson © UCLES.

Permission to reproduce items where third-party owned material protected by copyright is included has been sought and cleared where possible. Every reasonable effort has been made by the publisher (UCLES) to trace copyright holders, but if any items requiring clearance have unwittingly been included, the publisher will be pleased to make amends at the earliest possible opportunity.

University of Cambridge International Examinations is part of the University of Cambridge Local Examinations Syndicate (UCLES), which is itself a department of the University of Cambridge.