

Candidate Name \_\_\_\_\_

Centre Number	Candidate Number

**CAMBRIDGE INTERNATIONAL EXAMINATIONS**  
**General Certificate of Education Ordinary Level**

**FASHION AND FABRICS**  
PAPER 1 Theory

**6050/1**

**MAY/JUNE SESSION 2002**

2 hours

Additional materials:  
Answer paper  
Coloured pencils (not yellow)  
Ruler  
Small piece of fabric, needle and thread

**TIME** 2 hours

**INSTRUCTIONS TO CANDIDATES**

Write your name, Centre number and candidate number in the spaces at the top of this page and on any separate answer paper used.

**Section A**

Answer **all parts** of Question 1.

Write your answers in the spaces provided on the question paper.

**Section B**

Answer any **three** questions.

Write your answers on the separate answer paper provided.

At the end of the examination,

- 1 fasten the separate answer paper securely to the question paper.
- 2 enter the numbers of the Section B questions you have answered in the grid below.

**INFORMATION FOR CANDIDATES**

The number of marks is given in brackets [ ] at the end of each question or part question.

The insert is for use with Questions 1 and 7.

You are advised to spend no longer than 40 minutes on Section A.

You should illustrate your answers by means of clear, bold diagrams wherever possible. You may use a needle and thread and a small piece of fabric to help in making drawings of stitches. This fabric should not be handed in with your answers.

You may use the silhouettes on page 9 when preparing outlines for fashion sketches.

FOR EXAMINER'S USE	
Section A	
Section B	
<b>TOTAL</b>	

**This question paper consists of 9 printed pages, 3 blank pages and an insert.**

**Section A**

Answer **all** questions in the spaces provided.

1 (a) Using at least **two** words in each case, name the style features shown on the insert:

- |                |                |
|----------------|----------------|
| <b>A</b> ..... | <b>H</b> ..... |
| <b>B</b> ..... | <b>I</b> ..... |
| <b>C</b> ..... | <b>J</b> ..... |
| <b>D</b> ..... | <b>K</b> ..... |
| <b>E</b> ..... | <b>L</b> ..... |
| <b>F</b> ..... | <b>M</b> ..... |
| <b>G</b> ..... |                |

[13]

(b) It is suggested that this pattern is suitable for 'stretch knits only'. Explain why stretch knits are suitable for all the views shown in the insert sheet.

.....[2]

(c) (i) Cotton jersey is a fabric which would be suitable for the top, view A. Describe this fabric below:

- Structure .....
- Appearance .....
- Feel/handle .....
- Weight .....

[4]

(ii) Give **three** reasons why a cotton fibre is suitable for the top, view A.

.....  
.....  
.....[3]

(d) (i) State **three** body measurements which you would need in order to make the trousers, view D.

.....  
.....  
.....[3]

(ii) State **two** places where you could make an alteration on the pattern, if the trousers are too long.

.....  
.....[2]

(e) Complete the list of notions required to make the jacket, view C in size 15/16:

**Thread:** ..... type: .....

fibre content: ..... amount: .....

**Zip** (type): ..... length: .....

**Braid trimming** (fibre content): ..... amount: .....

**Seam binding** (width): ..... amount: .....

[10]

(f) The layout below is for the jacket, view C:

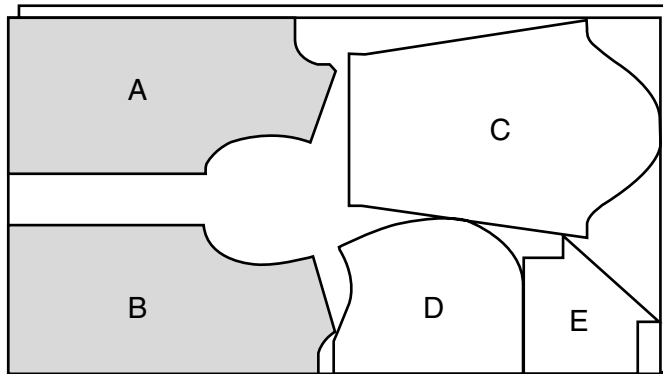

(i) Label the fold and selvages. [2]

(ii) Label the pattern pieces.

A .....

B .....

C .....

D .....

E .....

[5]

(iii) Mark the straight grain line(s) and/or fold line(s) on the layout above. [5]

(g) (i) Suggest **two** methods of transferring pattern markings after the cutting out has been completed.

.....

.....[2]

(ii) Describe, using labelled sketches, **one** of the methods of transferring pattern markings from (g) (i) above.

[4]

(h) Use the words from the list below, to complete the instructions for making the pocket, view C.

facing; machine; Baste; right side; 6 mm; seam;  
raw; large dots; raw; wrong side.

(i) Turn the slanted edge of pocket to

.....

along fold line, to make a facing.  
Baste.

Machine stitch along .....  
to secure facing.

Stay stitch the upper, side and lower

.....

edges.

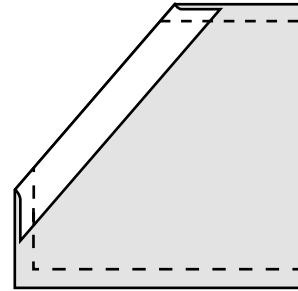

[3]

(ii) Turn facing to

.....

turning under.....

edges along stay stitching.  
Machine stitch 2.5 cm from outer edge of

.....

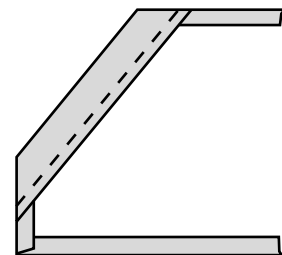

[3]

(iii) On outside, pin pocket to front, matching

.....

and keeping raw edges even. Baste, then

.....

stitch close to upper, side and lower edges and

also.....away.

Leave slanted edge open.

.....front edges of pocket  
and jacket together along raw edges.

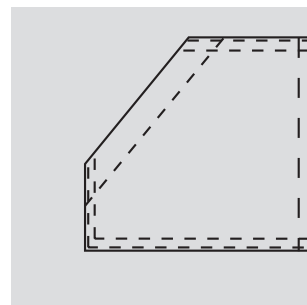

[4]

- (i) (i) Complete the details below for machining cotton jersey fabric which could be used for the top, view B:

Machine needle (type) ..... size .....[2]

Machine stitch for side seams:

Stitch length..... stitch width .....[2]

- (ii) Explain your choice of machine needle.

.....  
 .....[2]

- (iii) State **two** reasons why the machine stitch you have chosen is suitable for sewing the side seams on cotton jersey.

.....  
 .....[2]

- (j) (i) Suggest a suitable colour combination for the garments on the insert sheet.

Jacket .....

Trousers.....

Top view A .....

Top view B .....

Skirt ..... [2]

- (ii) Give **three** reasons for your choice of colours.

.....  
 .....  
 .....[3]

**Section B**

Answer **three** questions from this section.

- 2 (a) State the origin of cotton fibres and flax fibres. [2]
- (b) List and describe **six** properties which are common to **both** cotton and flax fibres. [6]
- (c) Name and describe **one** fabric made from flax. [5]
- (d) State **five** uses of fabrics made from flax and say why flax is a good choice for each example. [5]
- 3 Using notes and clearly labelled diagrams, explain how to:
- (a) level a skirt hem; [4]
- (b) turn up and tack a plain hem 5 cm wide on a straight skirt. [6]
- (c) Hand stitch the hem in place, using a suitable stitch. [5]
- (d) Press the completed hem correctly. [3]
- 4 (a) State **five** points to consider when choosing a new sewing machine. [5]
- (b) Explain how the machine should be used and cared for correctly. [4]
- (c) Explain how you would carry out the following by machine:
- (i) top-stitch a finished edge; [3]
- (ii) sew gathering threads on a sleeve head; [3]
- (iii) make a buttonhole. [3]
- 5 (a) Name **three** different neatened seams (**other than** an overlaid seam). State where each could be used on garments. [6]
- (b) Explain, using labelled diagrams, how to work an overlaid seam on a cotton gingham skirt. [8]
- (c) Describe how to press the seam. [4]

- 6 (a) Sketch and label the front and back views of a child's dress to show the use of:  
(i) single darts; (ii) tucks; (iii) easing. [6]
- (b) Explain using labelled diagrams the method of working:  
(i) single darts; [6]  
(ii) tucks. [4]
- (c) Describe how single darts should be pressed. [2]
- 7 Refer to the insert sheet.
- (a) Sketch and label a decorative hem for the skirt view E. Incorporate braid, ribbon and **two** hand embroidery stitches. [6]
- (b) Explain how to:  
(i) attach the braid and ribbon by machine; [6]  
(ii) work the two embroidery stitches by hand. [6]



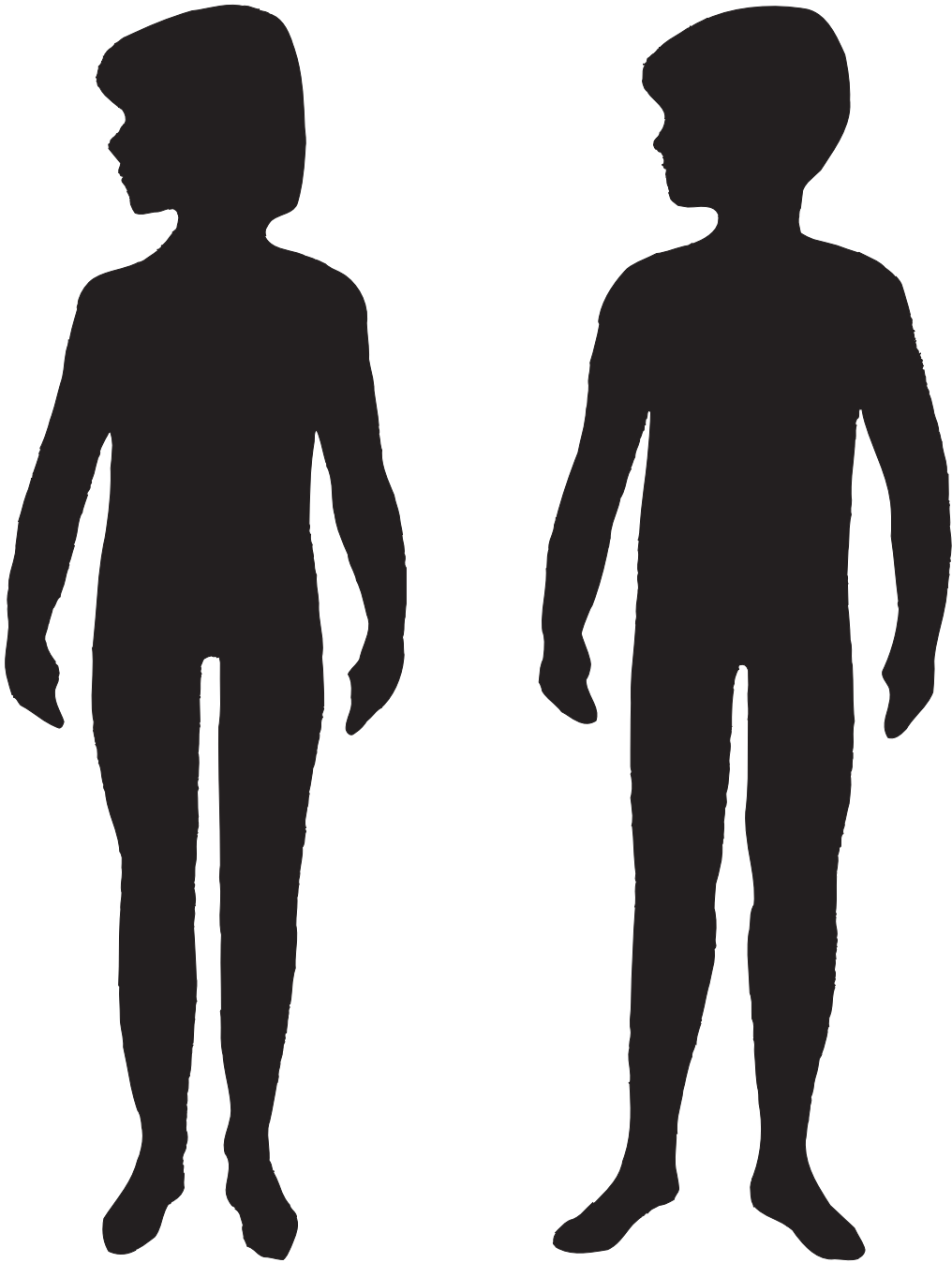







**CAMBRIDGE INTERNATIONAL EXAMINATIONS**  
**General Certificate of Education Ordinary Level**

**FASHION AND FABRICS**

PAPER 1 Theory

INSERT

**6050/1**

**MAY/JUNE SESSION 2002**

2 hours

**INSTRUCTIONS TO CANDIDATES**

The insert is for use with Questions 1 and 7.

---

**This insert consists of 4 printed pages.**



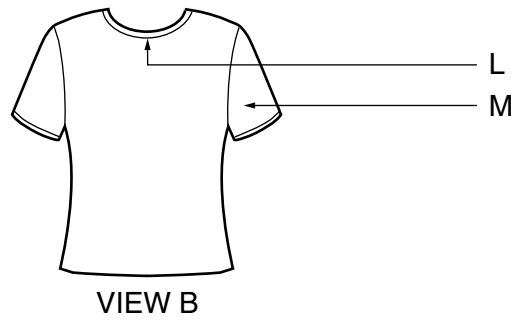
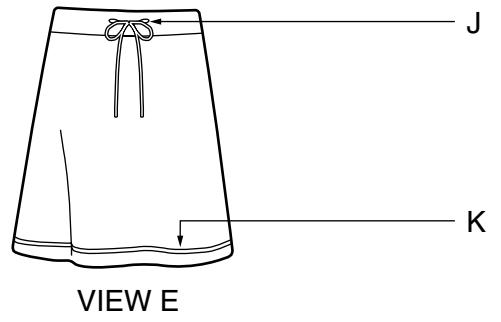
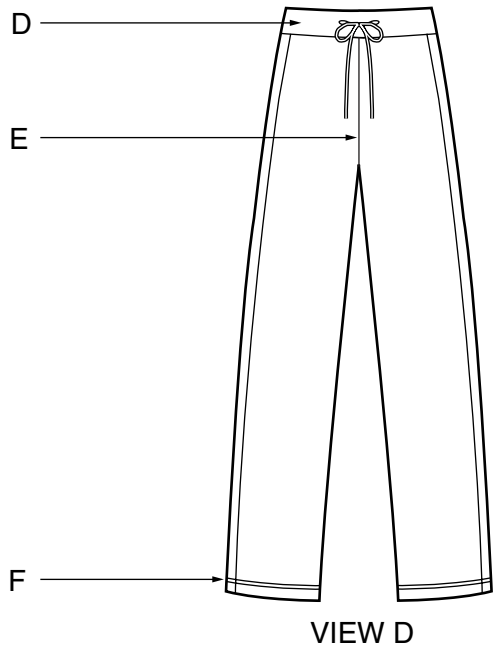
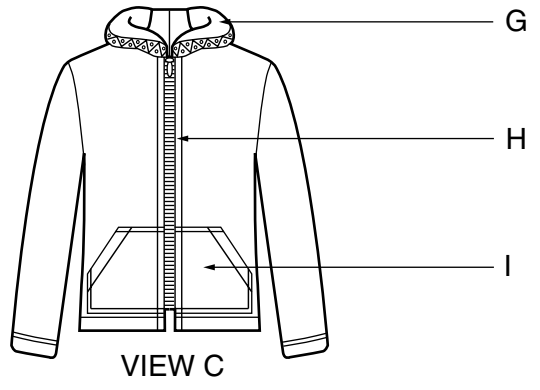
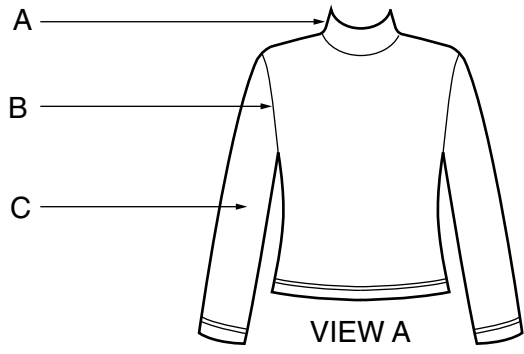

PICK-A-KNIT® **FOR THIS PATTERN--4" (10cm) OF KNIT FABRIC MUST STRETCH CROSSWISE FROM HERE**  
**RULE POUR CE PATRON--4" (10cm) DE TRICOT DOIVENT S'ETIRER EN TRAVERS D'ICI**

**TO HERE**  
**JUSQU'ICI**

# 8854

18 PIECES



**JUNIORS' KNIT TOP, JACKET, PANTS AND SKIRT AND KNIT OR WOVEN BELT:** Pullover top A, B has back zipper. A has long sleeves and band collar; B has short sleeves and round neckline. Hooded jacket C with front patch pockets has front zipper finished with ribbon or flat novelty braid trimming. Pull on pants D and skirt E have self or purchased cord drawstring at lowered waistline casing. D has optional ribbon or flat novelty braid trimming. Belt F has Velcro® closure and can be made with one or two hanging pockets. Suitable for Overlock/Serger.

**Fabrics:** Sized for stretch knits only. Cotton Interlock, Lightweight Double Knits, Jerseys, Stretch Velvet, Two Way Stretch. See Pick-A-Knit® Rule. A, B, C, D, E also in Velour. C, D, E also in Heepe. F also in Canvas, Denim, Twill. Extra fabric needed to match plaids, stripes or one-way design fabrics.

**Notions:** Thread. A, B, C: one pkg. straight seam basting. A: one 9" zipper. B: one 7" zipper. C: separating zipper. 15" for sizes 3/4-5/6, 18" for 7/8-9/10-11/12 and 20" for 13/14-15/16. F: 1" length of 1/2" wide Velcro®. Look for Simplicity notions and Simplicity Trims™. Check care instructions for all trims.

BODY MEASUREMENTS		28	29	30 1/2	32	33 1/2	35	36 1/2	Ir
Bust		28	29	30 1/2	32	33 1/2	35	36 1/2	Ir
Waist		22	23	24	25	26	27	28	"
Hip-7" below waist		31	32	33 1/2	35	36 1/2	38	39 1/2	"
Back-neck to waist		13 1/2	14	14 1/2	15	15 1/2	15 1/2	16 1/2	"
Sizes		3/4	5/6	7/8	9/10	11/12	13/14	15/16	
A - 60"***		3/4	5/6	7/8	9/10	11/12	13/14	15/16	Yd
B - 60"***		3/4	5/6	7/8	9/10	11/12	13/14	15/16	Yd
C - 60"***		1 1/4	1 1/2	1 3/4	1 3/4	1 3/4	1 3/4	1 3/4	Yd
Ribbon or Flat Novelty Braid Trimming - 2 1/2" wide		1 1/4	1 1/2	1 3/4	1 3/4	1 3/4	1 3/4	1 3/4	Yd
D - 60"***		1 1/4	1 1/2	1 3/4	1 3/4	1 3/4	1 3/4	1 3/4	Yd
Ribbon or Flat Novelty Braid Trimming (opt.) - 2 1/2" wide		1 1/4	1 1/2	1 3/4	1 3/4	1 3/4	1 3/4	1 3/4	Yd
E - 60"***		3/4	5/6	7/8	9/10	11/12	13/14	15/16	Yd

D, E Cord for Drawstring (opt.) - 1 1/4 yd. of 1/2" wide  
 F - includes two pockets - 3/4 yd or 45" or 60"\*\*\*  
 Interfacing - 1/2 yd. of 22" to 25" lightweight fusible

GARMENT MEASUREMENTS (Bust & Hip Printed on Pattern Tissue)		30	31	32 1/2	34	35 1/2	37	38 1/2	Ir
A, B - Bust		30	31	32 1/2	34	35 1/2	37	38 1/2	Ir
C - Bust		37	38	39 1/2	41	42 1/2	44	45 1/2	"
D - Hip		33	34	35 1/2	37	38 1/2	40	41 1/2	"
E - Hip		33	34	35 1/2	37	38 1/2	40	41 1/2	"
C length		20 1/2	20 1/2	22	22	22	23 1/2	23 1/2	"
D side length		37 1/2	38	38 1/2	39 1/2	40 1/2	41	41 1/2	"
D leg width		17	18	19	20	21	22	23	"
E length		16 1/2	17	17 1/2	18	18 1/2	19	19 1/2	"
E width		37 1/2	39	40 1/2	42 1/2	44 1/2	46	47 1/2	"

\*\*\*with nap; \*\*with nap; \*with or without nap

**HAUT, VESTE, PANTALON, JUPE EN JERSEYS ET CEINTURE EN JERSEY OU TISSU POUR JEUNES FILLES:** Hauts A, B avec glissière au dos. A avec manches longues et bande de col; B avec manches courtes et encolure arrondie. Veste à capuche C avec poches plaquées devant et glissière devant garnie de ruban ou de soutache plate fantaisie. Pantalon D et jupe E avec cordon en même tissu ou acheté pour la coulisse de la taille basse. D garni de ruban ou de soutache plate fantaisie facultatifs. Ceinture F avec fermeture de Velcro® et une ou deux poches détachées. La machine Overlock/Serger convient pour ces modèles.

**Tissus:** en jerseys extensibles seulement: Coton Interlock, Jerseys Doubles légers, Jerseys fins, Velours extensible, Jerseys extensibles dans les deux sens; Voyez la "Règle-Choisissez-Un-Jersey". A, B, C, D, E en Velours fin aussi. C, D, E en Molleton aussi. F en Grosse toile, Denim, Twill. Prévoyez davantage de tissu pour raccorder les écussons, rayures ou motifs unidirectionnels.

**Mercerie:** Fil A, B, C un paquet d'extra-fort rectiligne. A: une glissière de 23cm. B: une glissière de 18cm. C: glissière séparable 40cm pour les tailles 3/4-5/6, 45cm pour les tailles 7/8-9/10-11/12 et 50cm pour les tailles 13/14-15/16. F: Velcro®- 2.5cm de long de 2cm de large. Demandez la mercerie et les garnitures Simplicity. Voyez les instructions de lavage pour toutes les garnitures.

MESURES NORMALISEES		71	73.5	77.5	81.5	85	89	92.5	cm
Poitrine		71	73.5	77.5	81.5	85	89	92.5	cm
Taille		56	58.5	61	63.5	66	68.5	71	"
Hanches (18cm au-dessous de la taille)		78.5	81.5	85	88	92.5	96.5	100.5	"
Dos (encolure à taille)		34.5	35.5	37	38	39	40	41	"
Tailles		3/4	5/6	7/8	9/10	11/12	13/14	15/16	
A - 150cm**		0.80	0.80	1.00	1.10	1.20	1.20	1.30	m
B - 150cm**		0.70	0.70	0.70	0.90	0.90	0.90	1.00	m
C - 150cm**		1.40	1.40	1.40	1.40	1.40	1.50	1.50	m
Ruban ou soutache plate fantaisie- 2.0m de 1.3cm à 2cm de large		1.20	1.20	1.20	1.30	1.90	2.00	2.00	m
D - 150cm**		1.20	1.20	1.20	1.30	1.90	2.00	2.00	m
Ruban ou soutache plate fantaisie (facult.)- 2.30m de 2.5cm à 5cm de large		0.80	0.80	0.80	0.90	0.90	0.90	0.90	m
E - 150cm**		0.80	0.80	0.80	0.90	0.90	0.90	0.90	m

D, E Cordon pour coulisse (facult.)- 1.70m de 6mm de large  
 F - y compris deux poches- 0.60m de 1.5cm ou 150cm\*\*  
 Entoilage - 0.80m de 55cm à 64cm léger, thermocolant

MESURES DU VETEMENT (Tours de poitrine & hanches imprimés sur le papier de soie)		76	78.5	82.5	86.5	90	94	98	cm
A, B - Poitrine		76	78.5	82.5	86.5	90	94	98	cm
C - Poitrine		94	96.5	100.5	104	108	112	116	"
D - Hanches		84	86.5	90	94	98	102	106	"
E - Hanches		84	86.5	90	94	98	102	106	"
C longueur de la veste		52	52	56	56	56	59.5	59.5	"
D longueur de côté		94.5	96.5	98.5	100.5	102	104	106	"
D largeur de jambe		43	45.5	48.5	51	53.5	56	58.5	"
E longueur		42	43	44.5	45.5	47	48.5	49.5	"
E largeur		96	99	104	108	112	117	121	"

\*\*à deux sens; \*\*\*avec ou sans sens

---

*Copyright Acknowledgements:*

Pattern. © Simplicity Pattern Company Inc. Reprinted by permission.