

UNIVERSITY OF CAMBRIDGE INTERNATIONAL EXAMINATIONS  
General Certificate of Education Ordinary Level

**FASHION AND FABRICS**

**6050/02**

Paper 2 Practical Test

October/November 2005

**2 hours 30 minutes**

Additional Materials:

Sewing equipment	Sewing thread to match fabric
Fabric	Tacking thread
Pattern	Pencil
Interfacing	Ruler
	Scissors

This document consists of 4 printed pages.



**Materials provided**

- (a) Butterick pattern **6947**, size **8-10-12**.  
An illustration of the trousers, **view E**, is on the envelope containing the pattern.
- (b) A piece of fabric 115 cm wide and 46 cm long.
- (c) A piece of iron-on interfacing 12 cm wide and 20 cm long.
- (d) Sewing thread to match the fabric.
- (e) Tacking thread.

For this test you are to prepare the pattern and make up the right half of the shortened trousers, **size 12**, omitting the elastic at the back.

Before you begin, you should study the question paper carefully, together with the illustration, the pattern and the fabric.

This is a multi-size pattern. The cutting line for **size 12** is shown by **the outer black solid line**.

**A seam allowance of 1.5 cm is allowed within the pattern although it is not marked.**

**THE LABEL**

<p><b>Candidate's name</b></p> <p>.....</p> <p><b>Centre No./Index No.</b></p> <p>..... / .....</p>
---

## The Test

### 1 Preparation

- (a) Write your name and index number on the envelope provided.
- (b) Select and separate pattern pieces 7, 8, 9, 10 and 11 for the trousers, **View E**.
- (c) On pattern piece 8, the trouser back, measure 6 cm down from the crotch line, draw a line across and cut the bottom off along this line and keep the pattern piece labelled 8.
- (d) On pattern piece 7, the trousers front, measure 20 cm down from the Fold line (underneath Butterick 6947), draw a line across and cut the bottom off along this line and keep the pattern piece labelled 7.

### 2 Cutting out

- (a) Place the pattern pieces on the fabric as shown in the layout.
- (b) Cut out the right half of the shortened trousers.
- (c) Transfer the pattern markings which are needed for making up the test.
- (d) Cut out the interfacing as shown in the layout.

### 3 Making up

*It is important that pressing is done at all stages.*

Make up the right half of the shortened trousers as follows:

#### (a) Pleats

- (i) Fold the pleats in position on the front.
- (ii) Tack the pleats in position.

#### (b) Pocket

- (i) Attach the pocket to the front trouser matching the notch and balance mark.
- (ii) Turn the pocket to the inside.
- (iii) Topstitch 6 mm from the finished edge.
- (iv) Attach the side front pocket section to the pocket and neaten the seam.
- (v) On the outside, tack the upper and side edges in place.

#### (c) Front waistband

- (i) Fuse the interfacing to the wrong side of the waistband.
- (ii) Turn in the seam allowance on the unnotched edge of the waistband. Press.

#### (d) Attaching the waistband

- (i) Turn the seam allowance at the centre front of the front trouser to the wrong side and tack in place.
- (ii) Attach the waistband.
- (iii) Secure the inside of the waistband with a suitable hand sewn stitch.

**(e) Casing**

- (i) Turn the upper edge of the back trouser to the inside along the foldline, turning in 6 mm on the raw edge.
- (ii) Stitch close to upper and lower edges.

**(f) Side seam**

- (i) Join the back to the front and front waistband, at the side seam.
- (ii) Clip the back seam allowance below the casing. Press the seam open below the clip, pressing the remainder of the seam allowance towards the front waistband as shown.

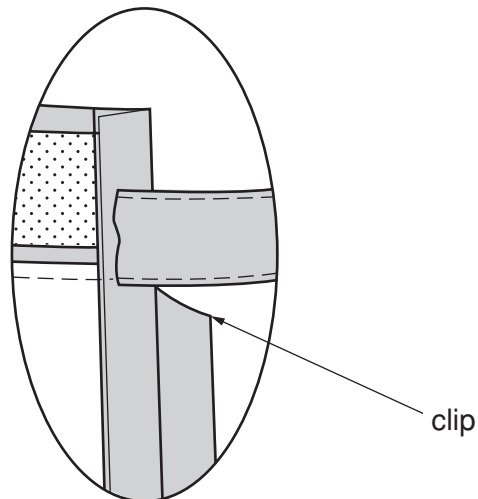

- (iii) Neaten the seam.
- (iv) Turn the front waistband to the inside along the foldline. Stitch the pressed edges over the seam.

**(g) Inner leg seam**

- (i) Join the front to the back at the inner leg seam.
- (ii) **Do not** neaten or trim this seam.

At the end of the examination remove the needle and unnecessary pins from your work. Write your name and index number on the label provided. Cut out the label and tack it to your test. The label should not cover any stitching and should be on **single** fabric. Press your work, fold it carefully and place it in the envelope provided. Do not include the scraps of fabric you have left over.

Permission to reproduce items where third-party owned material protected by copyright is included has been sought and cleared where possible. Every reasonable effort has been made by the publisher (UCLES) to trace copyright holders, but if any items requiring clearance have unwittingly been included, the publisher will be pleased to make amends at the earliest possible opportunity.

University of Cambridge International Examinations is part of the University of Cambridge Local Examinations Syndicate (UCLES), which is itself a department of the University of Cambridge.