

**DESIGN AND TECHNOLOGY**

**6043/13**

Paper 1 Technology

**October/November 2018**

**2 hours 30 minutes**

Additional Materials:      Answer Booklet/Paper  
   Plain paper  
   Sketching equipment



**READ THESE INSTRUCTIONS FIRST**

If you have been given an Answer Booklet, follow the instructions on the front cover of the Booklet.  
Write your Centre number, candidate number and name on the work you hand in.  
Write in dark blue or black pen.  
You may use an HB pencil for any diagrams, graphs or rough working.  
Do not use staples, paper clips, glue or correction fluid.  
**DO NOT WRITE IN ANY BARCODES.**

**Part A**

Answer **all** questions.

**Part B**

Answer **four** questions.

Answer **two** questions from Section 1 and **two** questions from Section 2.

You are advised to spend no longer than 45 minutes on Part A.  
Use sketches where appropriate to help answer any question. You may use coloured pencils.  
All dimensions are in millimetres.  
The number of marks is given in brackets [ ] at the end of each question or part question.

At the end of the examination, fasten all your work securely together.

This document consists of **9** printed pages and **3** blank pages.

## Part A

Attempt **all** questions.

1 Sketch a cross-section to show the structure of:

- (a) blockboard [1]
- (b) plywood. [1]

2 Fig. 1 shows a workshop tool.

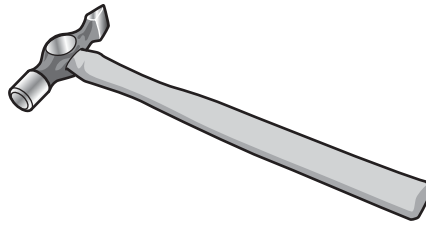

Fig. 1

- (a) Give the full name of the tool. [2]
- (b) State its purpose. [1]

3 State **three** safety precautions that you would take when using **either** a metal turning lathe **or** a wood turning lathe. [3]

4 Fig. 2 shows a boat hull.

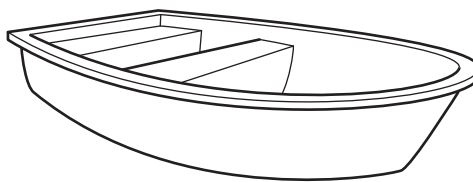

Fig. 2

State a suitable specific material for the manufacture of a boat hull. [1]

5 (a) State what each of the following would be used for:

- (i) Tensol cement [1]
- (ii) flux. [1]

(b) Describe briefly three stages included in using **either** Tensol cement **or** flux. [3]

6 Sketch the following tools.

(a) bevel-edged chisel [2]

(b) rasp [2]

7 Explain what is meant by the following workshop terms.

(a) hardening [2]

(b) annealing [2]

8 Fig. 3 shows a menu holder made from acrylic.

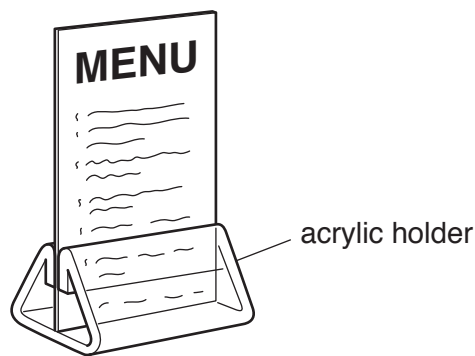

Fig. 3

Give **two** reasons why acrylic is a suitable material for the menu holder. [2]

9 State why:

(a) a hand file has one smooth edge [1]

(b) a try square has a brass strip on the wooden stock. [1]

10 (a) State what a shape memory alloy is. [1]

(b) Give a use for a shape memory alloy. [1]

## Part B

Attempt **four** questions, **two** from Section 1 and **two** from Section 2.

All questions carry equal marks.

## Section 1 – Tools and Materials

11 Three different marking out or measuring tools are shown in Fig. 4.

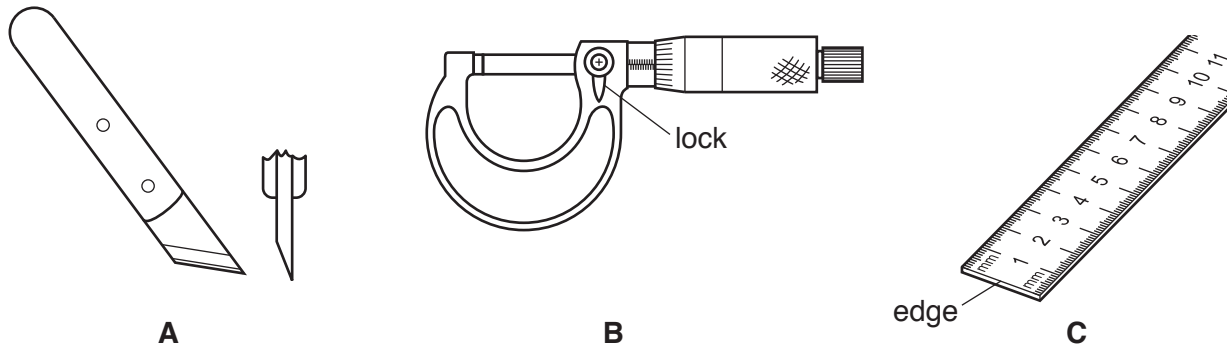

Fig. 4

(a) Name the marking out or measuring tools shown in Fig. 4 and state a specific use for each. [6]

(b) Explain:

(i) why the blade is only sharpened on one side on tool **A** [2]

(ii) the purpose of the lock on tool **B** [2]

(iii) why measurements start from the edge as shown on tool **C**. [2]

(c) Sketch the following and explain the purpose of each.

(i) mitre square [3]

(ii) centre punch [3]

12 (a) Adhesives are widely used to join metal, plastics and woods. For **each** of the following situations:

- metal to metal
- plastic to wood
- wood to wood

(i) name a suitable adhesive [3]

(ii) give details of surface preparation, application, and possible safety considerations. [9]

(b) Use sketches and notes to describe **one** method of joining materials using heat. [6]

- 13 The following materials are all used in the manufacture of products commonly used in a kitchen (food preparation area).

beech                  stainless steel                  pine                  polypropylene                  aluminium  
 high carbon steel                  melamine formaldehyde                  chipboard                  polythene

Select **six** materials from the list given and for each:

- (a) give an example of a kitchen product made from the material [6]
- (b) explain how the properties of the material make it appropriate for the example you have given. [12]

- 14 Fig. 5 shows the design for a bowling pin and bowling pins being struck by a bowling ball.

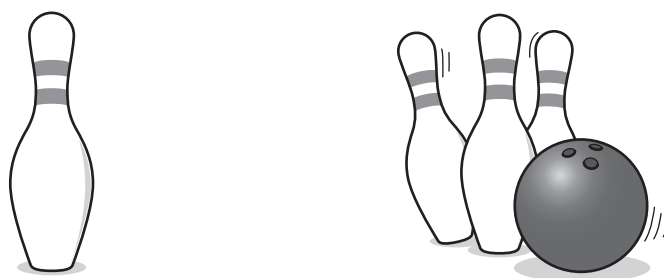

Fig. 5

- (a) State **two** properties that a material should have to be suitable for a bowling pin. [2]
- (b) A range of materials for the bowling pin were proposed but rejected. Give reasons why the following materials would not be suitable.
- (i) cast iron [2]
- (ii) acrylic [2]
- (iii) pine [2]
- (c) Suggest a suitable material for a bowling pin and sketch and label the tools or equipment that would be used to produce the bowling pin. [8]
- (d) Describe a method for checking that the shape and size of the bowling pins are the same if several are to be made. [2]

## Section 2 – Processes

15 Fig. 6 shows a design for a tape dispenser.

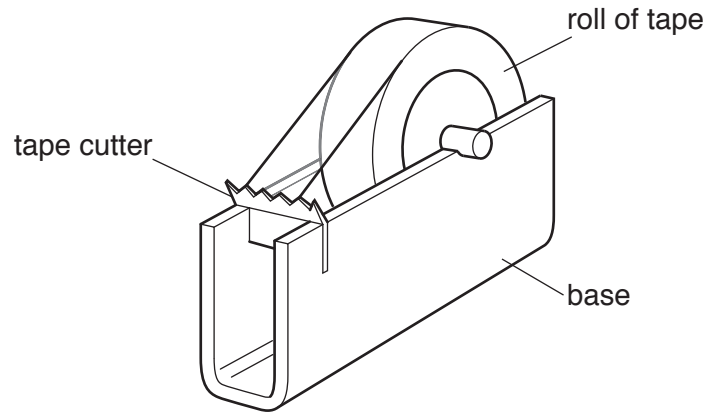
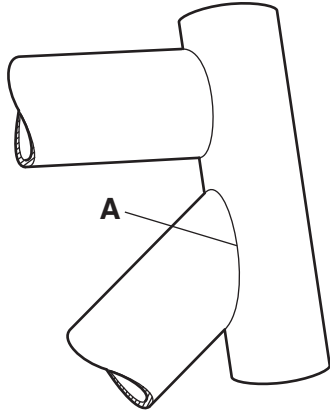

Fig. 6

- (a) (i) Suggest a suitable material for the base and give a reason for your choice. [2]
- (ii) Suggest a suitable material for the tape cutter and give a reason for your choice. [2]
- (b) Using the materials suggested in part (a), describe using sketches and notes how to:
- (i) make the base [5]
- (ii) make the tape cutter. [5]
- (c) Use sketches and notes to show how the roll of tape could be held more securely in the base. [4]

- 16 Fig. 7 shows three different processes used in the manufacture of products.  
Choose **two** of the processes and use sketches and notes to describe them.

Process A: **welding** the joint at **A** on the cycle frame



Process B: **press forming** the dish in HDPE (High Density Polyethylene)

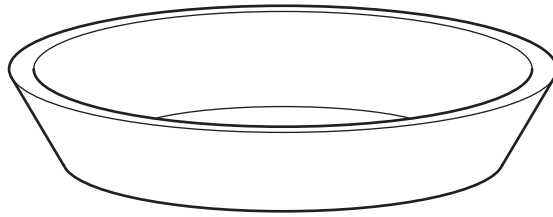

Process C: **cutting the housing joint** to join the shelf to the end

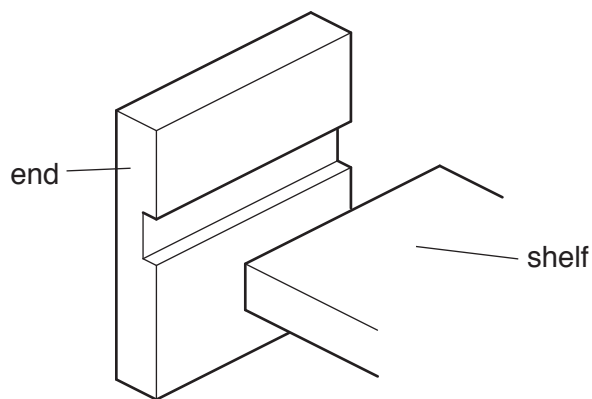
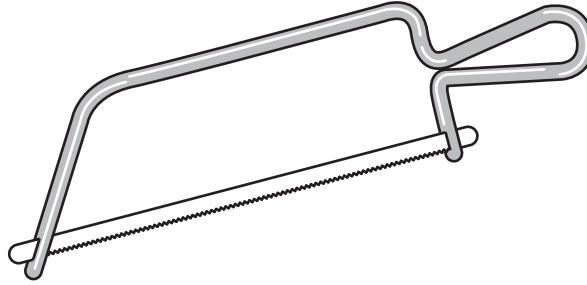

**Fig. 7**

[18]

- 17 (a) Give **three** reasons why surface finishes are applied to products. [3]
- (b) Describe in detail how the material surface is prepared and the finish is applied for **two** of the products shown in Fig. 8.

Product A: plastic coated junior hacksaw frame



Product B: turned wooden fruit bowl

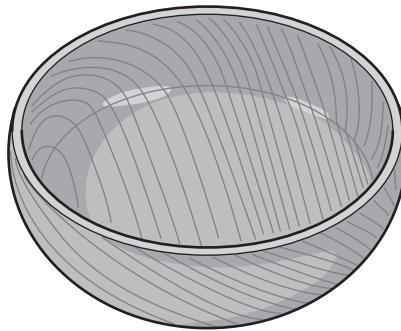

Product C: mild steel watering can

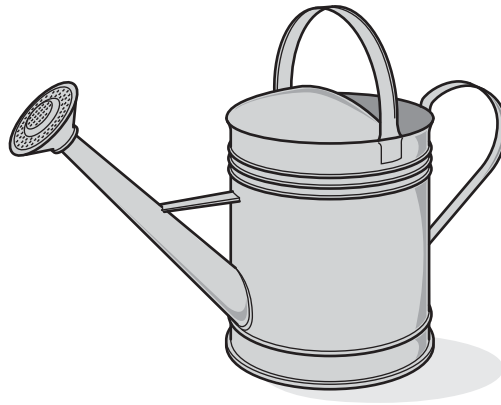

Fig. 8

[12]

- (c) Describe a method used to achieve a high-quality shine on a metal without using a surface coating. [3]



- 18 Fig. 9 shows three products made from different materials and manufactured using different processes.

Choose **two** of the products and use sketches and notes to describe in detail how they would be made.

Product A: jewellery container made from copper sheet

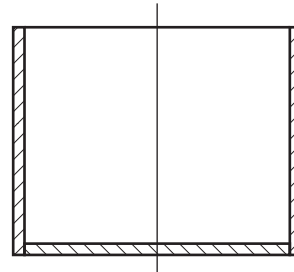
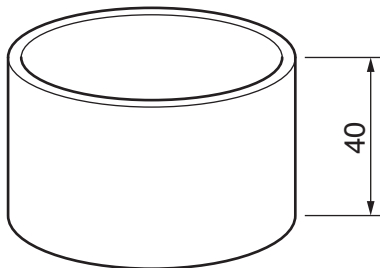

sectional view of container

Product B: die cast aluminium drawer handle

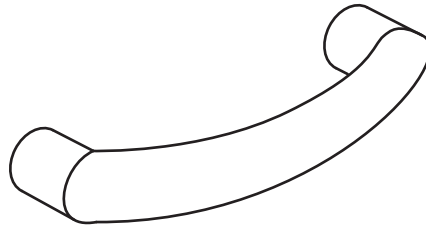

Product C: bottom part of a motorcycle top box made from glass-fibre-reinforced polymer (GRP)

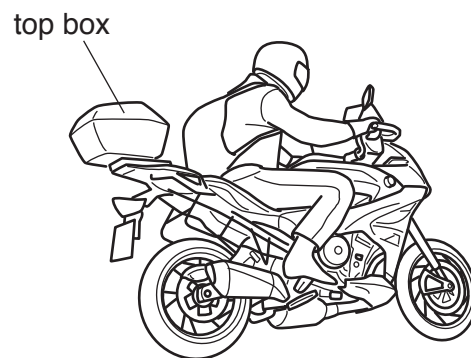
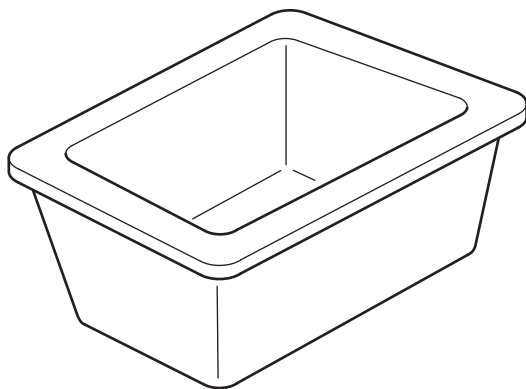

Fig. 9

[18]





**BLANK PAGE**

---

Permission to reproduce items where third-party owned material protected by copyright is included has been sought and cleared where possible. Every reasonable effort has been made by the publisher (UCLES) to trace copyright holders, but if any items requiring clearance have unwittingly been included, the publisher will be pleased to make amends at the earliest possible opportunity.

To avoid the issue of disclosure of answer-related information to candidates, all copyright acknowledgements are reproduced online in the Cambridge International Examinations Copyright Acknowledgements Booklet. This is produced for each series of examinations and is freely available to download at [www.cie.org.uk](http://www.cie.org.uk) after the live examination series.

Cambridge International Examinations is part of the Cambridge Assessment Group. Cambridge Assessment is the brand name of University of Cambridge Local Examinations Syndicate (UCLES), which is itself a department of the University of Cambridge.