



UNIVERSITY OF CAMBRIDGE INTERNATIONAL EXAMINATIONS
General Certificate of Education Ordinary Level

DESIGN AND TECHNOLOGY

6043/01

Paper 1 Technology

October/November 2008

2 hours 30 minutes

Additional Materials: Answer Booklet/Paper
 Plain paper
 Sketching equipment



READ THESE INSTRUCTIONS FIRST

Write your Centre number, candidate number and name on all the work you hand in.

Write in dark blue or black.

You may use a soft pencil for any diagrams, graphs or rough working.

Do not use staples, paper clips, highlighters, glue or correction fluid.

Part A

Answer **all** questions.

Part B

Answer **four** questions.

Answer **one** question from Section 1, **two** questions from Section 2, and **one** other question from either Section.

Use sketches where appropriate to help answer any question.

You are advised to spend no longer than 45 minutes on Part A and 1 hour 45 minutes on Part B.

At the end of the examination, fasten all your work securely together.

The number of marks is given in brackets [] at the end of each question or part question.

This document consists of **11** printed pages and **1** blank page.



Part A

You are advised to spend no more than 45 minutes on this part.

Attempt **all** questions.

1 Sketch the following:

(a) a marking knife;

(b) a scribe.

[4]

2 Fig. 1 shows a bathroom blind pull.

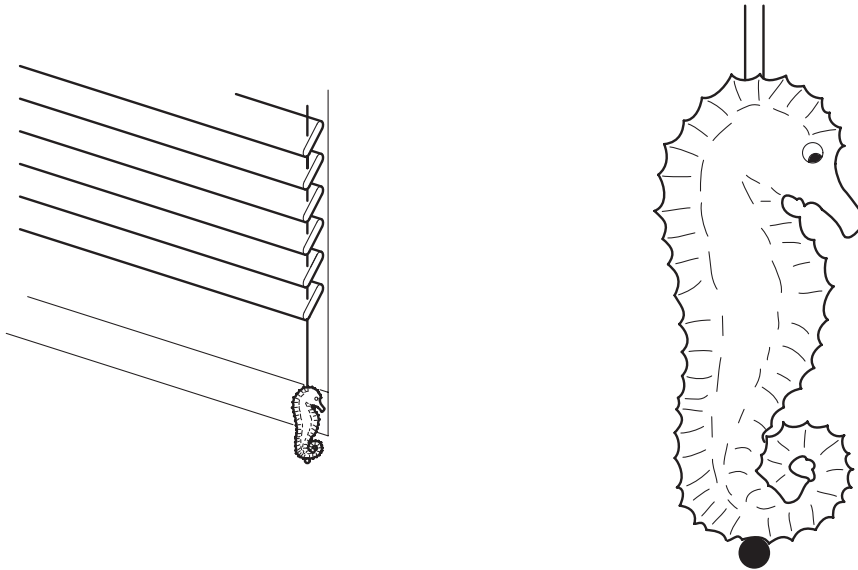

Fig. 1

Give **two** reasons why plastic is a more suitable material for the blind pull than wood or metal. [2]

3 Explain what is meant by the term 'annealing' when applied to metal.

[2]

4 Fig. 2 shows a wood fitting.

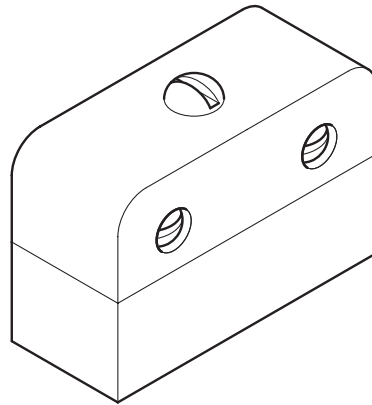

Fig. 2

(a) Name the fitting.

(b) Explain its use.

[3]

5 Flow charts are used at various stages when designing and making.

(a) Describe **two** key features of a flow chart.

(b) Suggest an operation that could usefully be illustrated by a flow chart.

[3]

6 State **two** methods of keeping plastic cool while it is being machined.

[2]

7 Fig. 3 shows an outdoor bench made from pine.

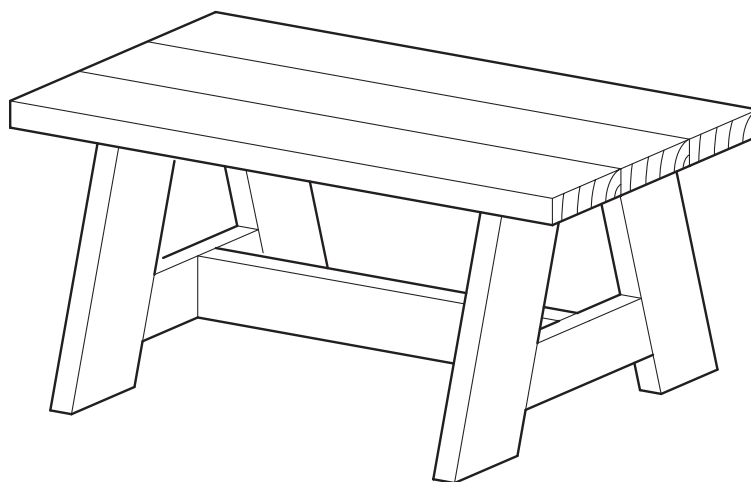

Fig. 3

(a) Why does pine need to be treated for use outdoors?

(b) State **two** treatments that could be applied to the pine bench to protect it in outdoor conditions.

[3]

- 8 Explain briefly the process of 'draw filing' steel. [2]
- 9 State the personal protection that should be worn when:
- (a) handling catalysts and resins;
 - (b) machine sanding timber;
 - (c) handling hot metal;
 - (d) lathe turning. [4]
- 10 Fig. 4 shows a three dimensional shape which is to be cut from a block of expanded polystyrene.

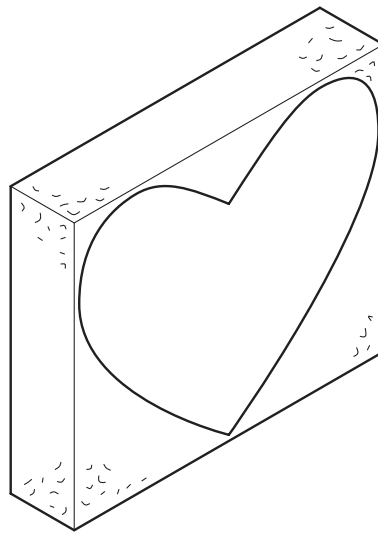

Fig. 4

- (a) Why is it difficult marking out this material?
- (b) What tool would be used to cut the polystyrene? [2]

Part B

You are advised to spend at least 1 hour 45 minutes on this part of the examination.

Attempt **four questions** including **one** from Section 1, **two from** Section 2 and **one further** question from either section.

All questions carry equal marks.

Section 1 – Tools and Materials

11 Fig. 5 shows details of three marking out tools used in the workshop.

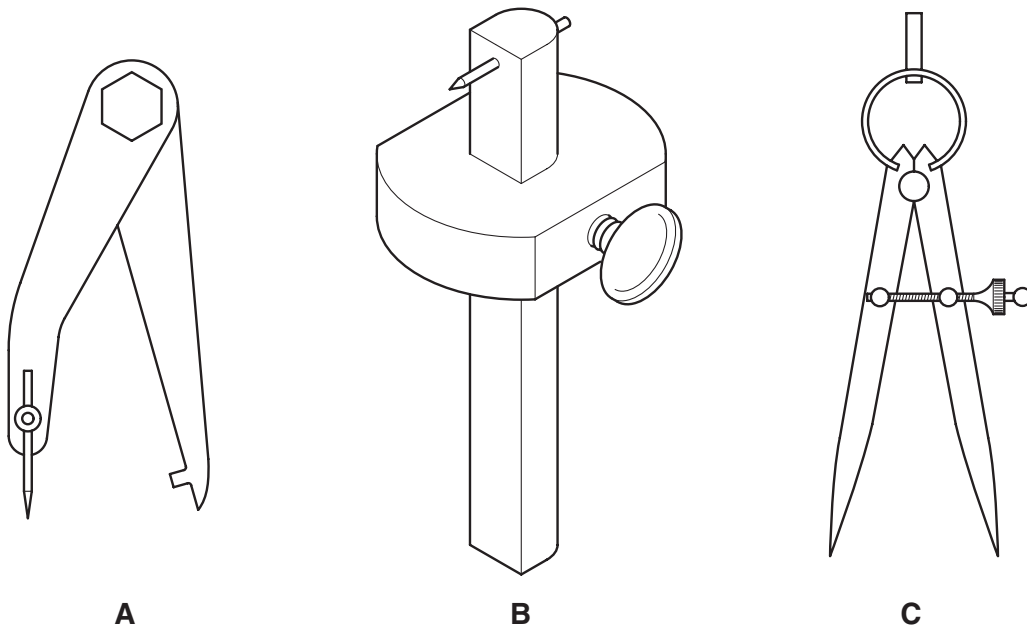

Fig. 5

- (a) Name and state the purpose of each of the tools. [6]
- (b) Using notes and sketches, explain how each of the above tools is set up for use. [6]
- (c) Explain the purpose of the following tools:
- (i) a surface plate;
 - (ii) a sliding bevel. [5]

12 When making several identical parts or products, simple devices are commonly used to ensure they are all the same. Explain the benefits of **four** of the following when making a number of identical items.

- (a) a template
- (b) a pattern
- (c) a former
- (d) a jig
- (e) a mould

[17]

13 The design for a door handle is shown in Fig. 6.

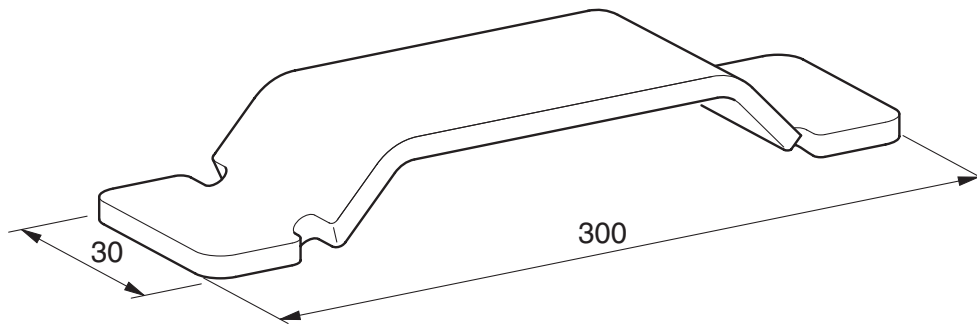

Fig. 6

(a) Some possible materials being considered for the handle are:

- (i) brass;
- (ii) teak;
- (iii) acrylic.

For each material give **one** reason for selecting and **one** reason for rejecting it as a suitable material for the handle. [6]

(b) Describe how heat or steam are used when forming the handle shape from each of the materials in (a). [6]

(c) Give the reasons for:

- (i) having paper on the surface of acrylic sheet;
- (ii) using pumice powder on the surface of brass;
- (iii) oil to the surface of teak.

[5]

Section 2 – Processes

14 Fig. 7 shows the outline details for a butterfly brooch.

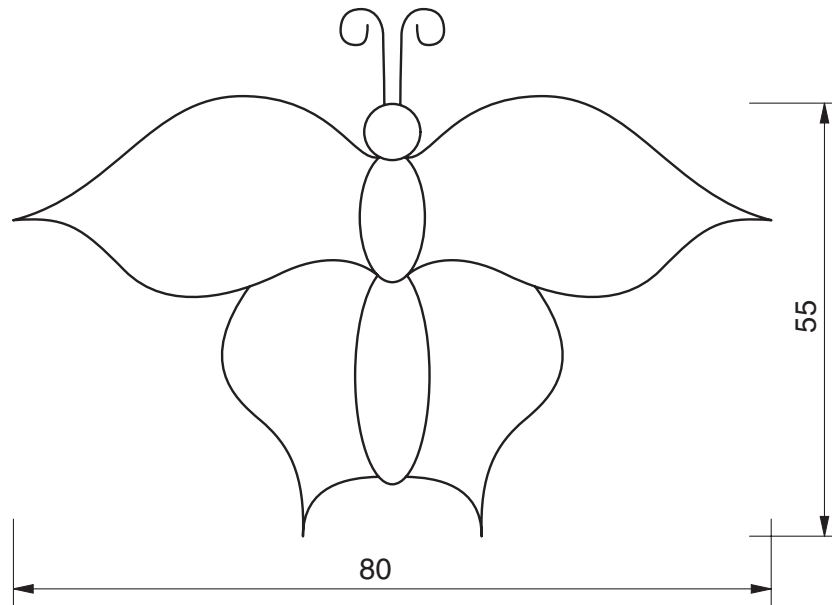

Fig. 7

- (a) Suggest a suitable material for the brooch (this does **not** include the antennae) and give a reason for your choice. [2]
- (b) Using the material chosen in (a), describe, the process of marking out and cutting the brooch shape. [8]
- (c) The design of the brooch is incomplete.
- (i) Show by means of a sketch, a design for the surface of the wings. [2]
- (ii) Explain in detail how the design may be applied to the brooch surface. [5]

15 Fig. 8 gives details of an outdoor direction sign.

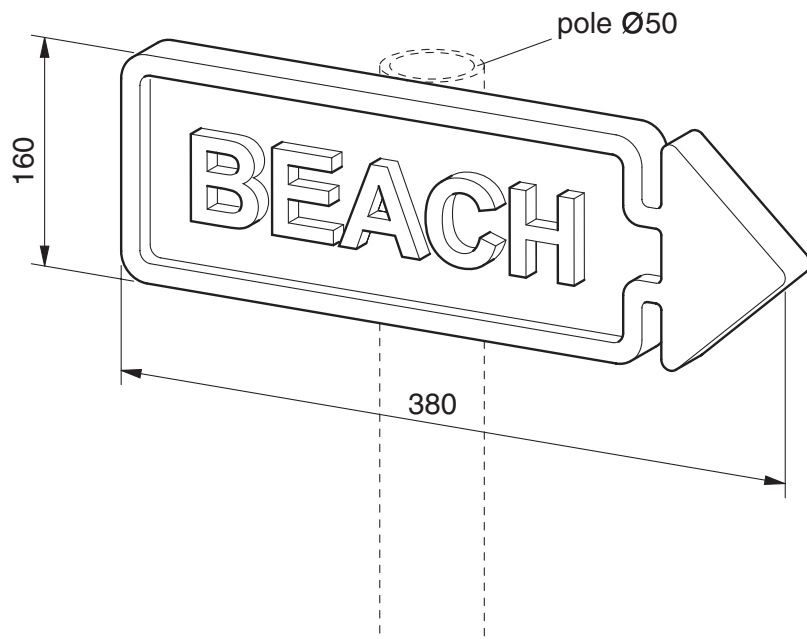

Fig. 8

(a) Suggest, with a reason:

(i) a suitable material for the sign;

(ii) a method of manufacture.

[2]

(b) For the material and manufacturing method you suggested in answer to **(a)**, use notes and sketches to describe the major stages in making the direction sign. [10]

(c) Show by means of design sketches how the sign could be fixed to the top of a 1 metre \times $\text{Ø}50$ mm support pole. The method should allow the sign to be positioned in any horizontal direction. [5]

16 Choose **two** of the tasks in Fig. 9 and, using notes and sketches, describe how each is carried out.

(a) silver soldering a joint in a copper cylinder

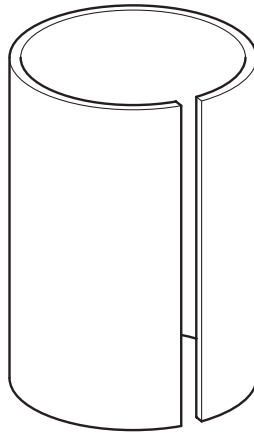

(b) cutting a bridle joint in a pine upright and rail

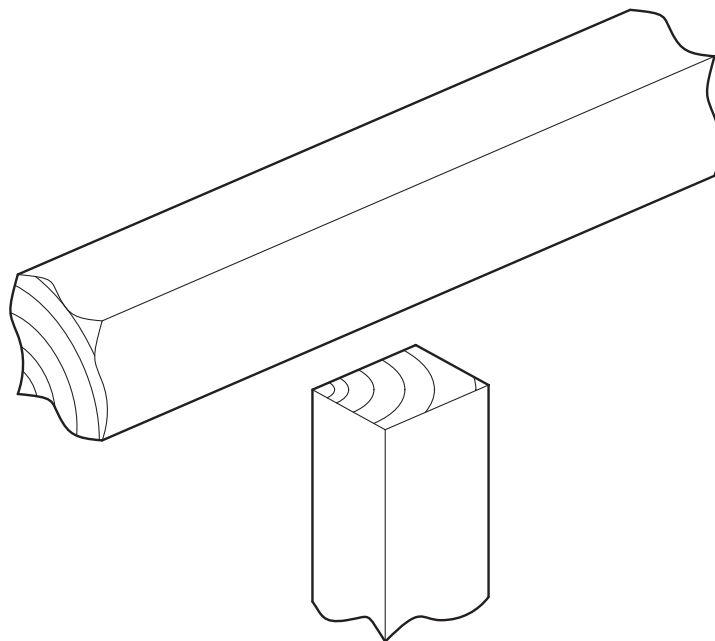

(c) press forming an acrylic water bowl

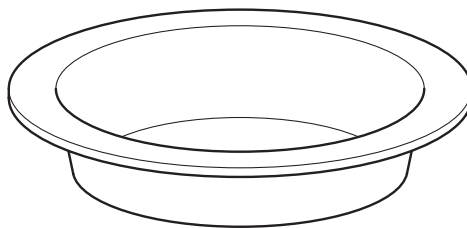

Fig. 9

[17]

17 A design for a tracing surface and part of a three position support stand is shown Fig. 10.

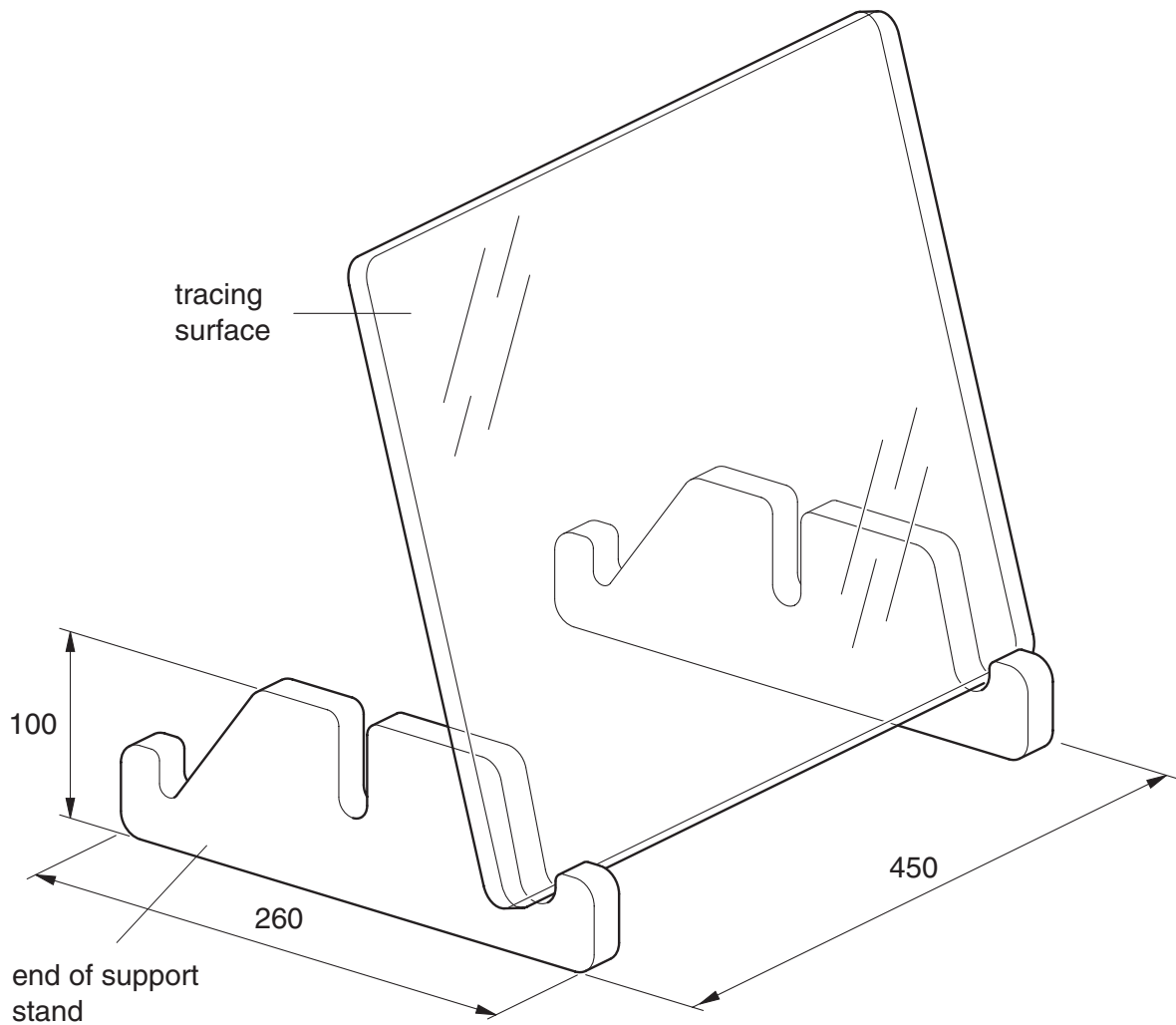

Fig. 10

- (a) Explain how tracing is used in design work. [2]
- (b) State **two** properties of a material that would make it suitable for the tracing surface. [2]
- (c) Using a material of your own choice, describe using notes and sketches the stages of making the two ends of the support stand. [8]
- (d) With the aid of sketches show how the two ends of the support stand could be joined to provide a firm base unit. [5]

18 Details of a flower press are given in Fig. 11.

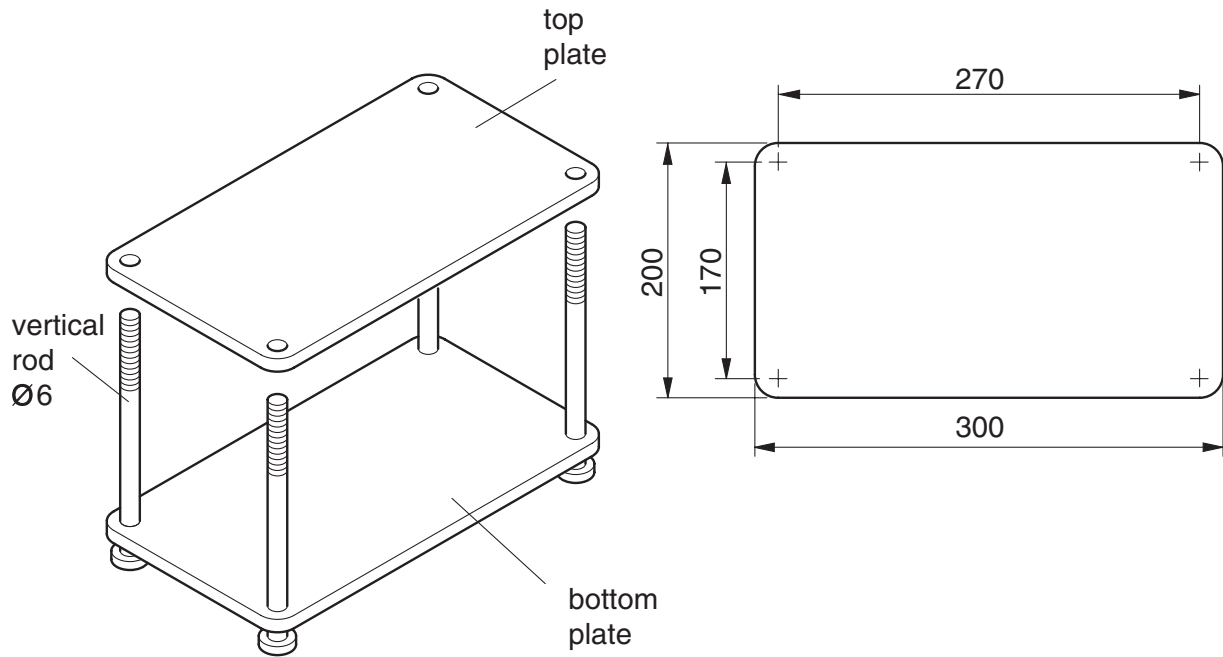

Fig. 11

- (a) Describe, with the aid of notes and sketches, each of the following processes. You must state the materials used for each part.
- (i) threading the vertical rods
 - (ii) drilling the holes in the top and bottom plates to ensure alignment
 - (iii) production of the radiused corners on the top and bottom plates, including holding method. [15]
- (b) Each vertical rod requires a hand tightening device that can apply pressure to the top plate. Sketch such a device. [2]

Permission to reproduce items where third-party owned material protected by copyright is included has been sought and cleared where possible. Every reasonable effort has been made by the publisher (UCLES) to trace copyright holders, but if any items requiring clearance have unwittingly been included, the publisher will be pleased to make amends at the earliest possible opportunity.

University of Cambridge International Examinations is part of the Cambridge Assessment Group. Cambridge Assessment is the brand name of University of Cambridge Local Examinations Syndicate (UCLES), which is itself a department of the University of Cambridge.