



DESIGN AND TECHNOLOGY

6043/01

Paper 1 Technology

October/November 2007

2 hours 30 minutes

Additional Materials: Answer Booklet/Paper
 Plain paper
 Sketching equipment

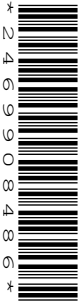

READ THESE INSTRUCTIONS FIRST

Write your Centre number, candidate number and name on all the work you hand in.
Write in dark blue or black.
You may use a soft pencil for any diagrams, graphs or rough working.
Do not use staples, paper clips, highlighters, glue or correction fluid.

Part A

Answer **all** questions.

Part B

Answer **four** questions.

Answer **one** question from Section 1, **two** questions from Section 2, and **one** other question from either Section.

Use sketches where appropriate to help answer any question.
You are advised to spend no longer than 45 minutes on Part A and 1 hour 45 minutes on Part B.
At the end of the examination, fasten all your work securely together.
The number of marks is given in brackets [] at the end of each question or part question.

This document consists of **11** printed pages and **1** blank page.



Part A

You are advised to spend no more than 45 minutes on this part.

Attempt **all** questions.

- 1 Give **two** methods of seasoning timber. [2]
- 2 Fig. 1 shows two parts of a workshop tool.

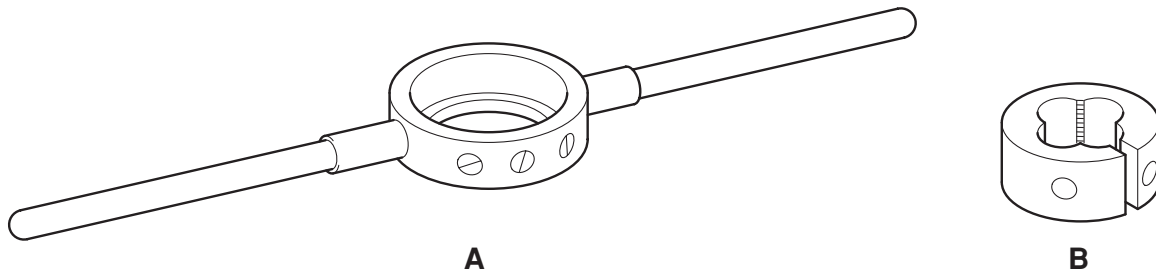

Fig. 1

- (a) Name the **two** parts.
- (b) Give a specific use for the tool. [3]
- 3 Explain what is meant by the term 'plastic memory' when applied to acrylic. [2]
- 4 Fig. 2 shows a wooden puzzle. State **two** possible ways of colouring the surface. [2]

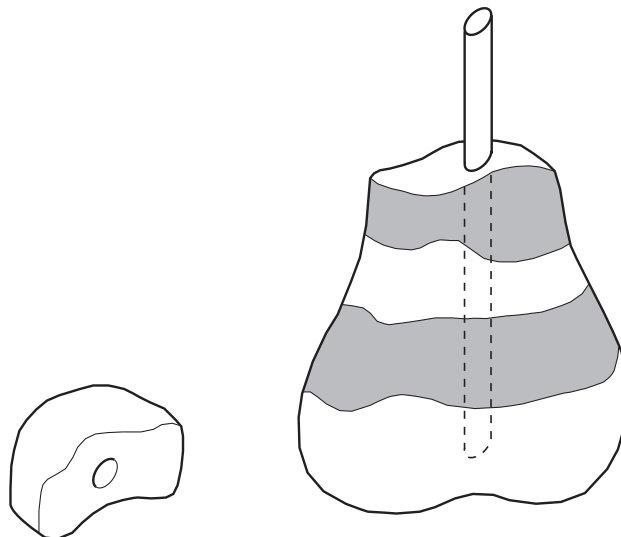

Fig. 2

- 5 Explain why a designer would carry out market research before starting a design project. [3]

6 Sketch the following tools:

(a) nail punch;

(b) centre punch.

[4]

7 Fig. 3 shows a plastic measuring spoon used when baking.

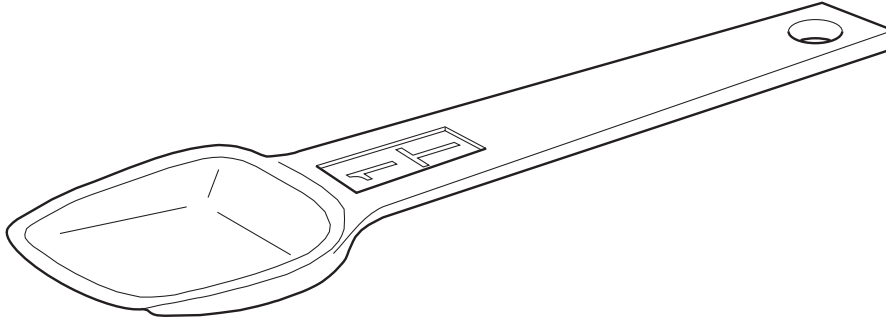

Fig. 3

(a) Name a suitable plastic for the spoon.

(b) Give **two** reasons for your choice.

[3]

8 Explain the purpose of tempering tool steel.

[2]

9 Sketch the following wood joints:

(a) dowelled;

(b) mitre.

[4]

10 Fig. 4 shows a figure made by the injection moulding process.

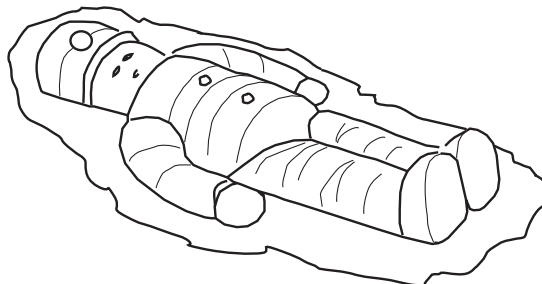

Fig. 4

(a) What is the name given to the surplus material around the figure?

(b) Give a reason for this fault.

[2]

Part B

You are advised to spend at least 1 hour 45 minutes on this part of the examination.

Attempt **four questions** including **one** from Section 1, **two from** Section 2 and **one further** question from either section.

All questions carry equal marks.

Section 1 – Tools and Materials

11 Fig. 5 shows three different drilling devices.

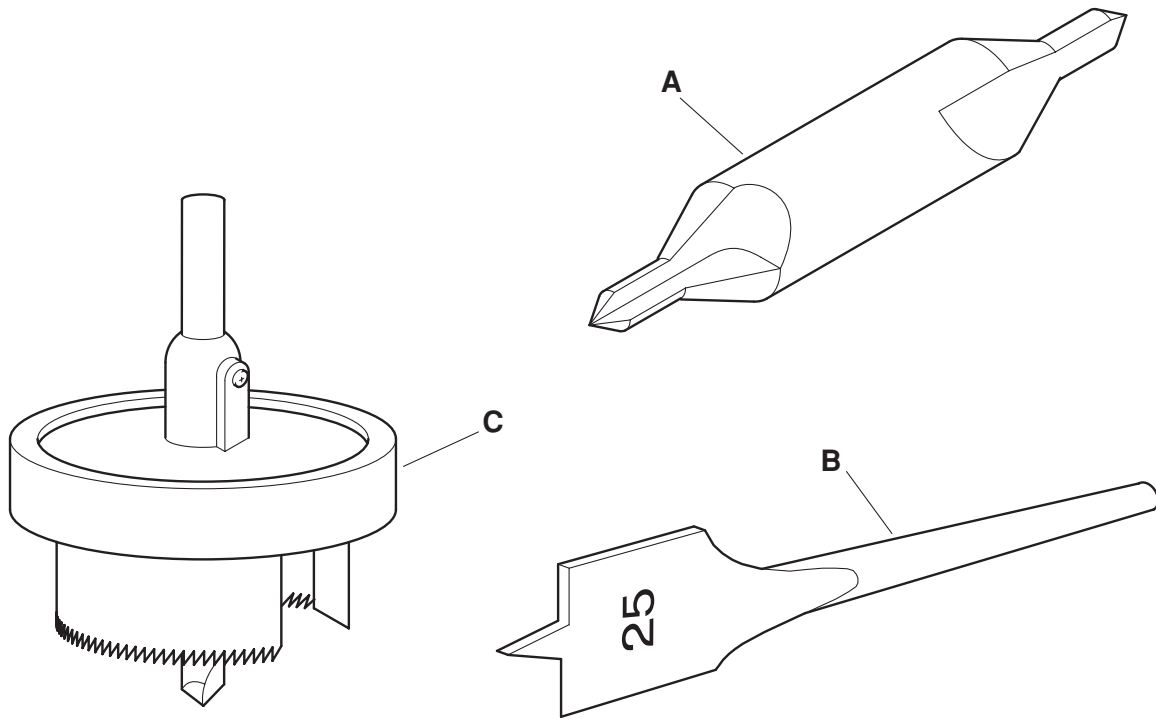

Fig. 5

- (a) Identify each device shown in Fig. 5 and state its purpose. [6]
- (b) Explain:
- (i) how drill **A** is held and operated;
 - (ii) why precautions should be taken when using drill **B**.
 - (iii) why the waste material cut by drill **C** can be a problem. [9]
- (c) Sketch a morse taper shank as used on larger twist drills. [2]

12 Using a suitable joining medium is one of the many problems that have to be solved when working on projects.

(a) Copy and complete the chart shown below.

Joining medium	Materials that can be joined	Particular advantages
P.V.A. adhesive		
Epoxy resin adhesive		
Tensol cement		
Brazing spelter		
Contact or impact adhesive		

[15]

(b) State **two** qualities that surfaces must have in order to provide good joining areas for adhesives, cements and solders. [2]

13 The design for a plate used in joining wooden display boards is shown in Fig. 6.

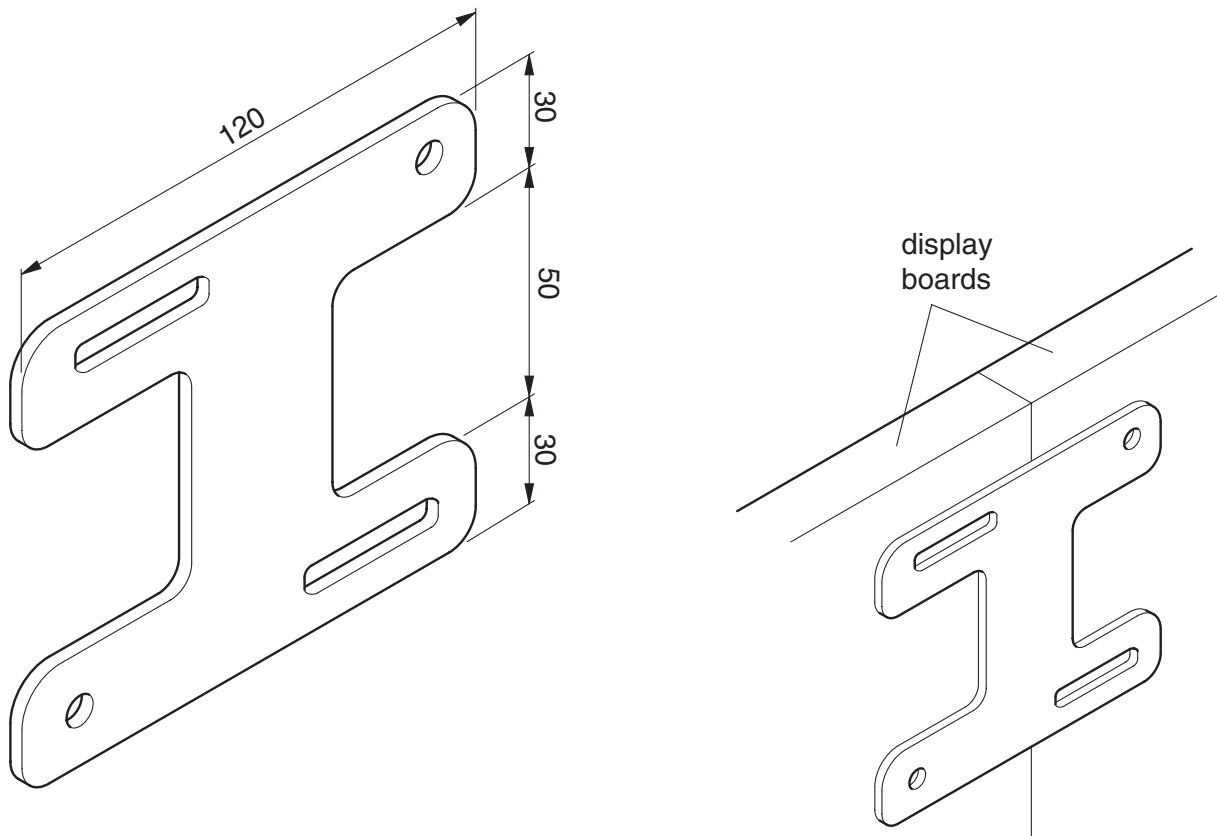

Fig. 6

(a) Some possible materials being considered for the plate are:

- (i) aluminium;
- (ii) birch plywood;
- (iii) nylon.

Give **one** reason for selecting and **one** reason for rejecting **each** material listed. [6]

(b) Choose **one** of the materials named in part (a) and show, using notes and sketches, how the plate would be held and supported:

- (i) when drilling the holes;
- (ii) whilst being shaped. [6]

(c) Sketch **two** possible methods of fixing the plate to the wooden display boards. [5]

Section 2 – Processes

14 Fig. 7 shows details of a small jewellery box.

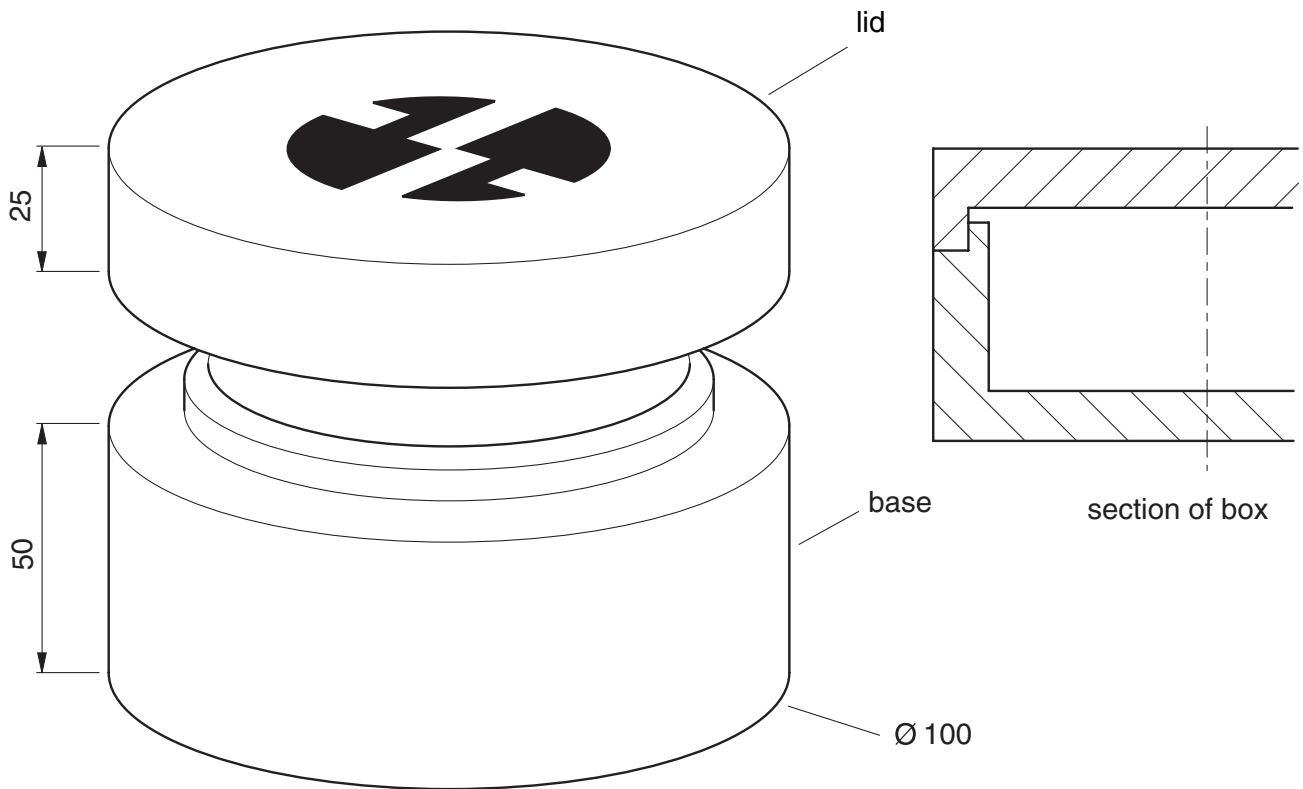

Fig. 7

- (a) Suggest a suitable material for the box and give a reason for your choice. [2]
- (b) Using the material chosen in (a), describe the process for making the box base. [8]
- (c) Show by means of a sketch, a design for the lid, based on any two letters of your name. [2]
- (d) Explain in detail how the design chosen in (c) may be applied to the lid surface. [5]

- 15 A playground see-saw as shown in Fig. 8 is proving to be in a dangerous condition and needs replacing.

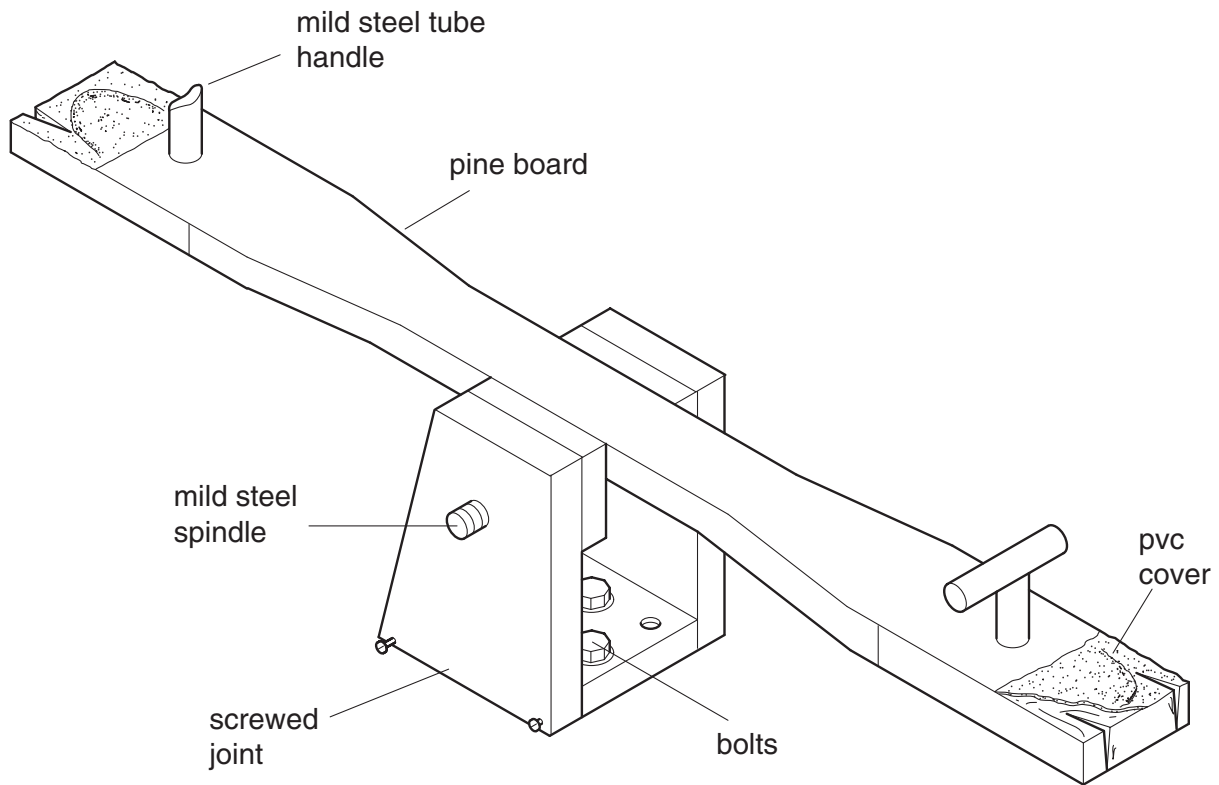

Fig. 8

- (a) Identify and explain a potential danger associated with any **five** features named in Fig. 8. [5]
- (b) Using notes and sketches, suggest how each of these features may be modified to improve safety in a replacement see-saw. [10]
- (c) Suggest **two** possible methods of protecting a softwood such as pine from decay when it is exposed to the weather. [2]

16 Fig. 9 gives details of a tool holder that is to be made of sheet material.

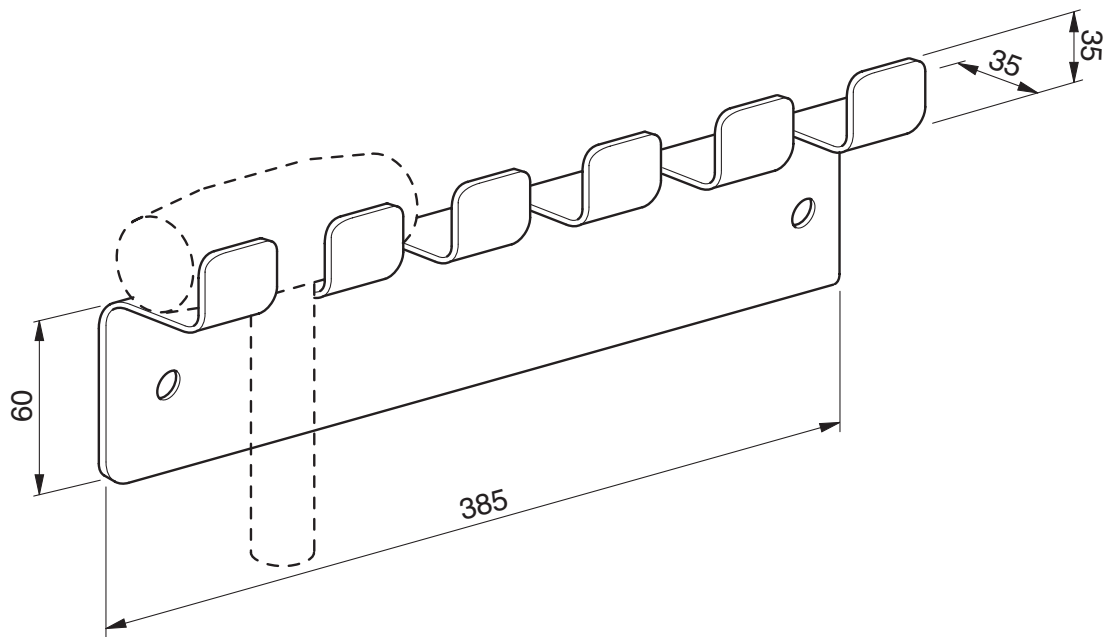

Fig. 9

- (a) Choose a suitable **sheet** material for the tool holder and give the reason for your choice. [2]
- (b) Describe, with the aid of notes and sketches, each of the following processes used in making the tool holder when:
- (i) cutting the outline;
 - (ii) forming the shape;
 - (iii) producing a final surface finish.

[15]

17 An adjustable work table for the disabled is shown in Fig. 10.

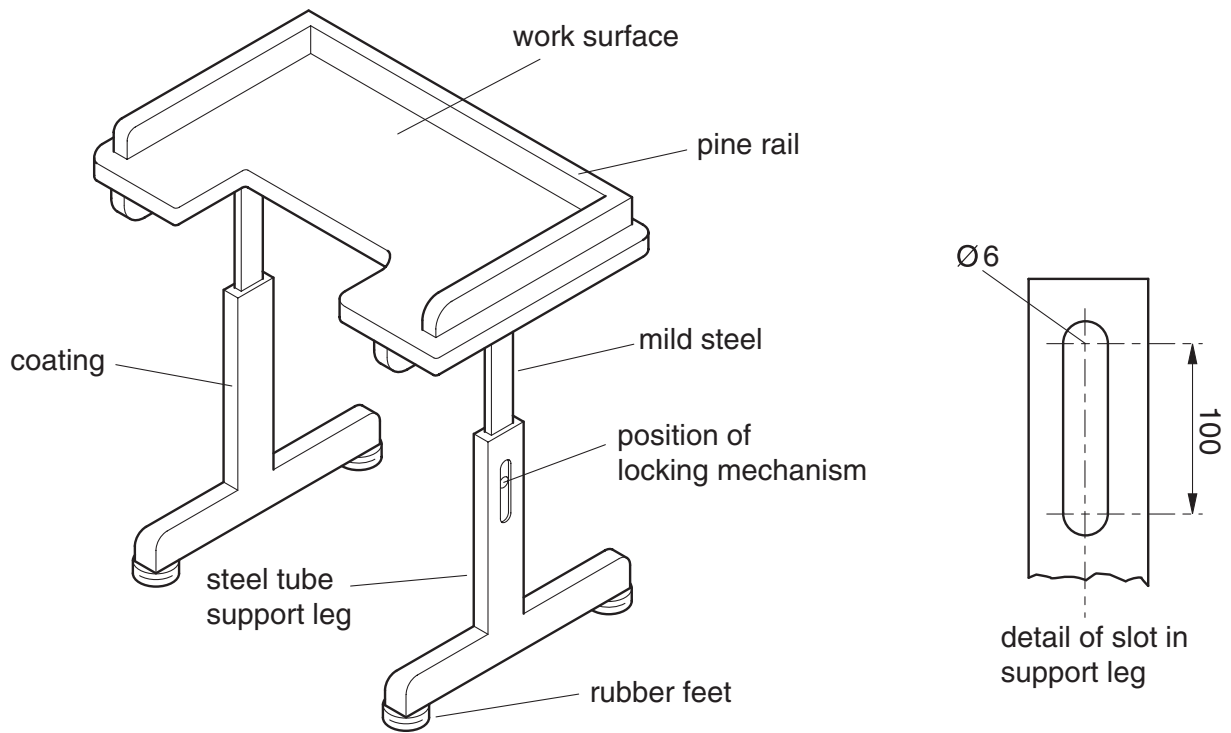

Fig. 10

(a) Give **one** reason in each case why the following materials are suitable for the parts named:

- (i) birch plywood – work surface;
- (ii) mild steel tube – support legs;
- (iii) polythene coating – support legs;
- (iv) rubber – feet.

[4]

(b) Describe the stages of:

- (i) joining the pine rail to the birch plywood work surface;
- (ii) cutting a slot in the support leg.

[10]

(c) Make a sketch of a suitable hand locking mechanism, for the adjustable leg.

[3]

18 Details of a pull-along toy are given in Fig. 11.

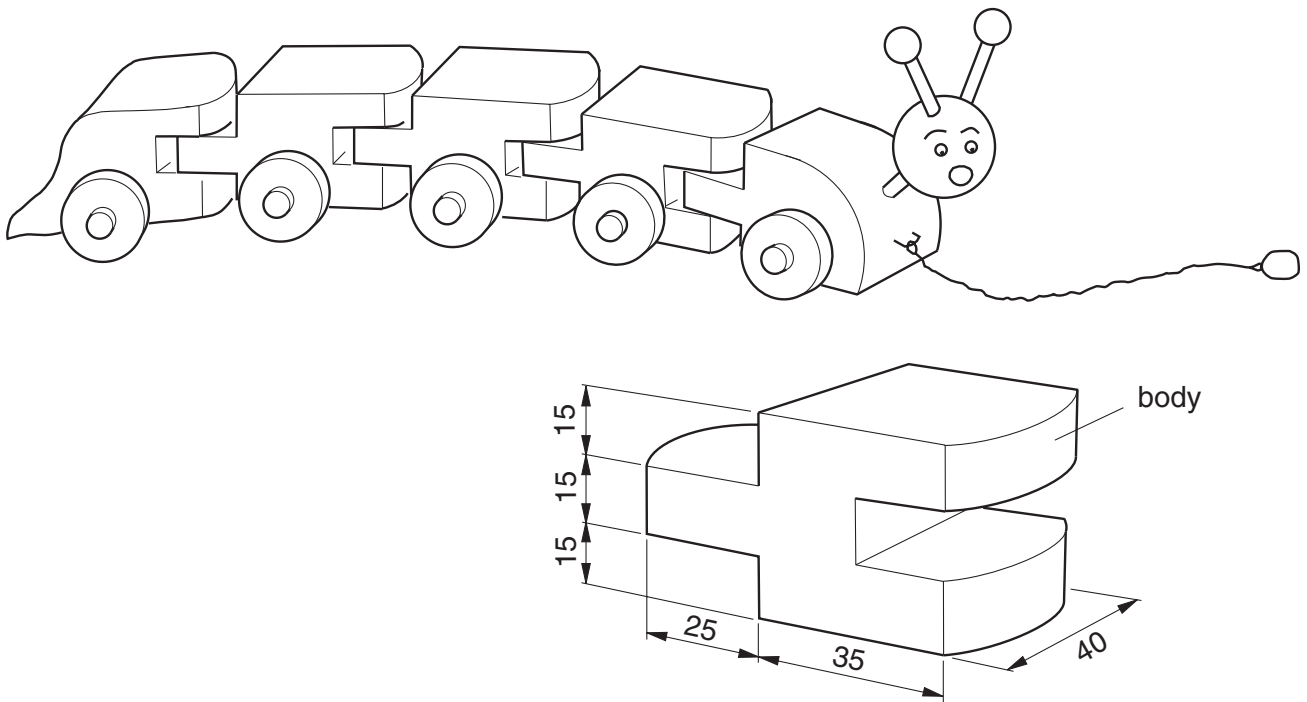

Fig. 11

- (a) Give **three** safety features that any pull-along toy should have. [3]
- (b) Use notes and sketches to describe the main stages in making one body part using any **two** of the following methods.
- (i) Injection moulding (plastic)
 - (ii) Cast (light alloy metal)
 - (iii) Built up/joined (wood) [12]
- (c) Show, by means of a sketch, how the head of the toy could be made to move up and down when the toy is pulled along. [2]

BLANK PAGE

Permission to reproduce items where third-party owned material protected by copyright is included has been sought and cleared where possible. Every reasonable effort has been made by the publisher (UCLES) to trace copyright holders, but if any items requiring clearance have unwittingly been included, the publisher will be pleased to make amends at the earliest possible opportunity.

University of Cambridge International Examinations is part of the Cambridge Assessment Group. Cambridge Assessment is the brand name of University of Cambridge Local Examinations Syndicate (UCLES), which is itself a department of the University of Cambridge.