

UNIVERSITY OF CAMBRIDGE INTERNATIONAL EXAMINATIONS
General Certificate of Education Ordinary Level

DESIGN AND TECHNOLOGY

6043/01

Paper 1 Technology

October/November 2006

2 hours 30 minutes

Additional Materials: Answer Booklet/Paper
Plain paper
Sketching equipment

READ THESE INSTRUCTIONS FIRST

Write your Centre number, candidate number and name on all the work you hand in.
Write in dark blue or black pen.
You may use a soft pencil for any diagrams, graphs or rough working.
Do not use staples, paper clips, highlighters, glue or correction fluid.

Part A

Answer **all** questions

Part B

Answer **four** questions.

Answer **one** question from Section 1, **two** questions from Section 2, and **one** other question from either Section.

Use sketches where appropriate to help answer any question.

You are advised to spend no longer than 45 minutes on Part A and 1 hour 45 minutes on Part B.

At the end of the examination, fasten all your work securely together.

The number of marks is given in brackets [] at the end of each question or part question.

This document consists of **11** printed pages and **1** blank page.



Part A

You are advised to spend no more than 45 minutes on this part.

Attempt **all** questions

- 1 Name the two forms of woodwork construction shown in Fig. 1. [2]

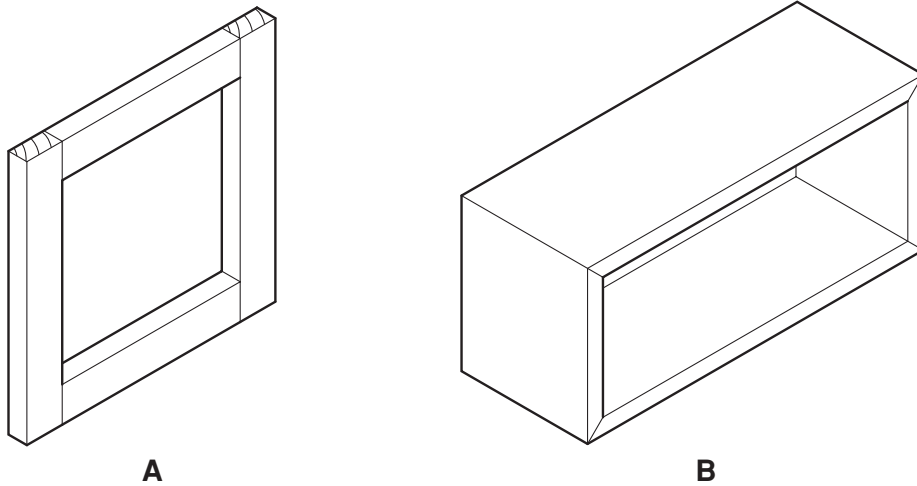

Fig. 1

- 2 Sketch a hand file and state the reason for it having one smooth edge. [3]
- 3 Give **two** reasons why evaluation is important in design [2]
- 4 Fig. 2 shows a cooking pan made entirely from metal.

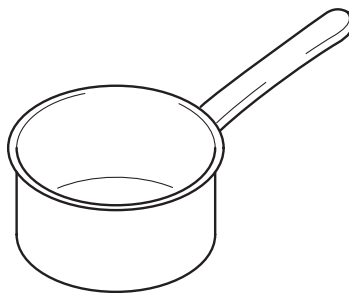

Fig. 2

- (a) State a suitable metal for the pan and give a reason.
- (b) Why could the metal handle be a problem? [4]

- 5 State **two** precautions you should take when working with glass reinforced plastic [GRP]. [2]
- 6 Sketch cross-sections of the following processed boards.
- (a) Plywood
 - (b) Chipboard
 - (c) Blockboard
- [3]
- 7 Give **two** reasons why PVC plastic would be a suitable material for the beach ball shown in Fig. 3. [2]

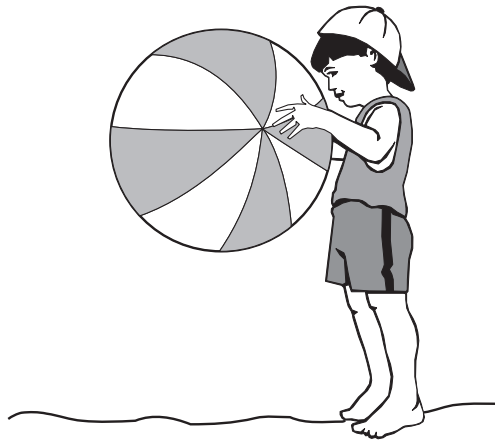

Fig. 3

- 8 State **two** properties that can help to identify a timber. [2]
- 9 Sketch the following fixings.
- (a) wing nut
 - (b) panel pin
- [4]
- 10 Explain the term 'fluidization' as applied to plastics. [3]

Part B

You are advised to spend at least 1 hour 45 minutes on this part of the examination.

Attempt **four questions** including **one** from Section 1, **two from** Section 2 and **one further** question from either section.

All questions carry equal marks.

Section 1 – Tools and Materials

11 Many measuring devices and testing methods are used to check work. Three are shown in Fig. 4.

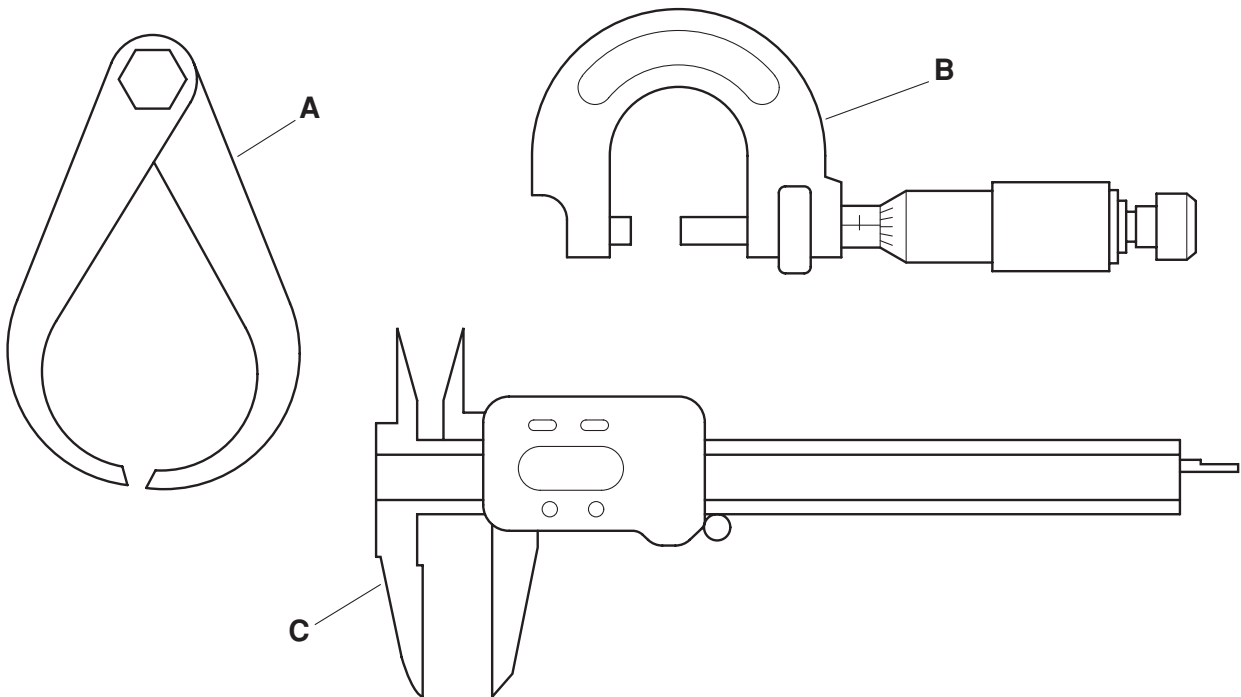

Fig. 4

- (a) Identify each of the measuring or testing devices shown in Fig. 4 and explain the purpose of each. [6]
- (b) Explain:
- (i) how device **A** is used to take a measurement;
 - (ii) how device **B** measures an item and what system stops it being over-tightened;
 - (iii) how device **C** has ease of reading and what makes it multi purpose. [9]
- (c) Explain why device **A** is the least accurate. [2]

12 Many projects fail because the designer does not consider the environment in which the material is to be used.

(a) Explain the effect of the following.

(i) salt water on a softwood boat ladder

(ii) a too high a wattage [or high power] light bulb on an acrylic shade

(iii) a leaking lead acid battery on a mild steel support [6]

(b) Using examples, explain how

(i) water,

(ii) heat,

(iii) acid

can each be used to advantage on materials. [6]

(c) Explain how air helps in the following situations.

(i) newly cut planks of timber

(ii) hot metal casting

(iii) making a plastic bottle [5]

13 Fig. 5 shows three products which have had their basic materials modified during manufacture.

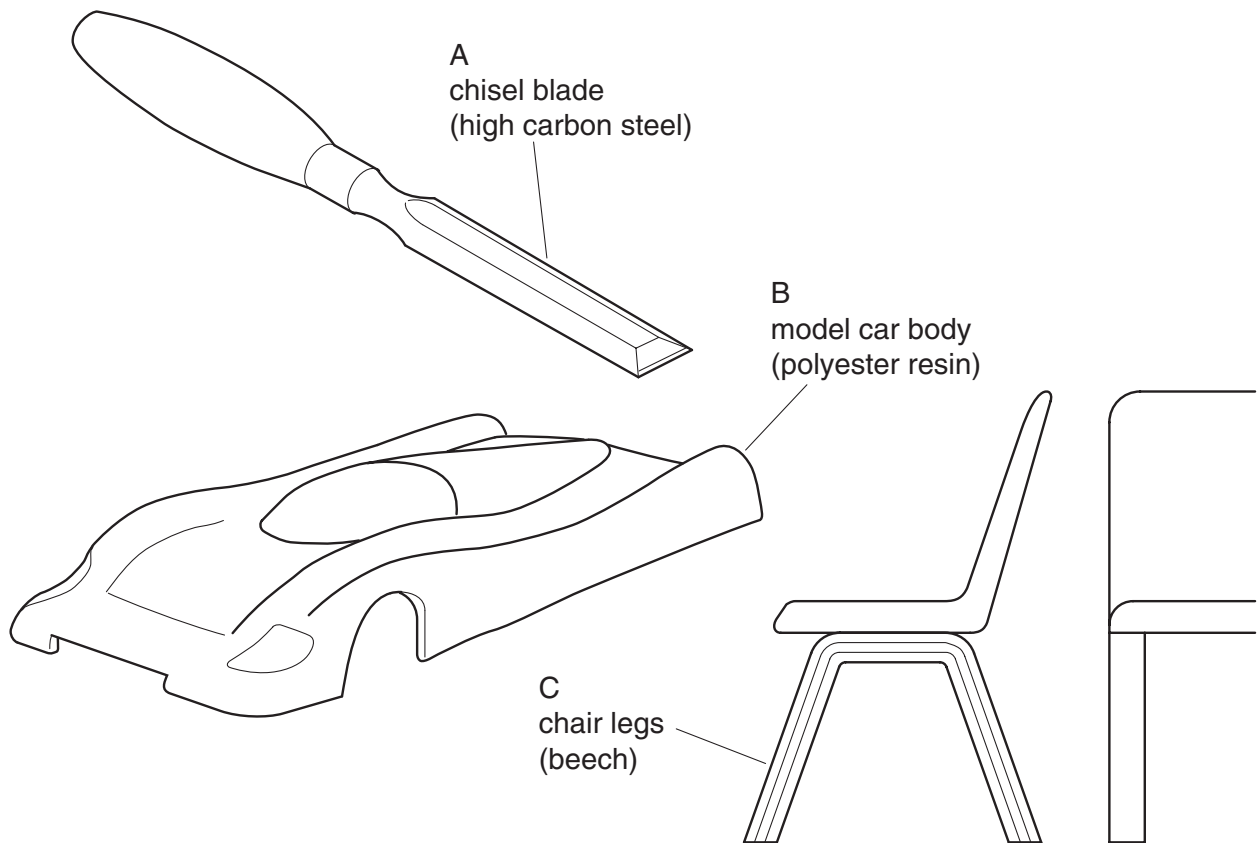

Fig. 5

- (a) State briefly how each of the materials has been modified to improve strength. [6]
- (b) Explain the following.
- (i) Why regrinding a chisel blade can affect the strength of the cutting edge.
 - (ii) How the smooth outside surface is achieved on the model car body.
 - (iii) How a former is used in the making of the chair legs. [6]
- (c) State briefly how the following materials are improved by the addition of the second material.
- (i) mild steel with carbon powder
 - (ii) polyester resin with an accelerator
 - (iii) blockboard with melamine [5]

Section 2 – Processes

- 14 Fig. 6 shows details of a control unit for a string puppet that is made up from **two** parts joined together.

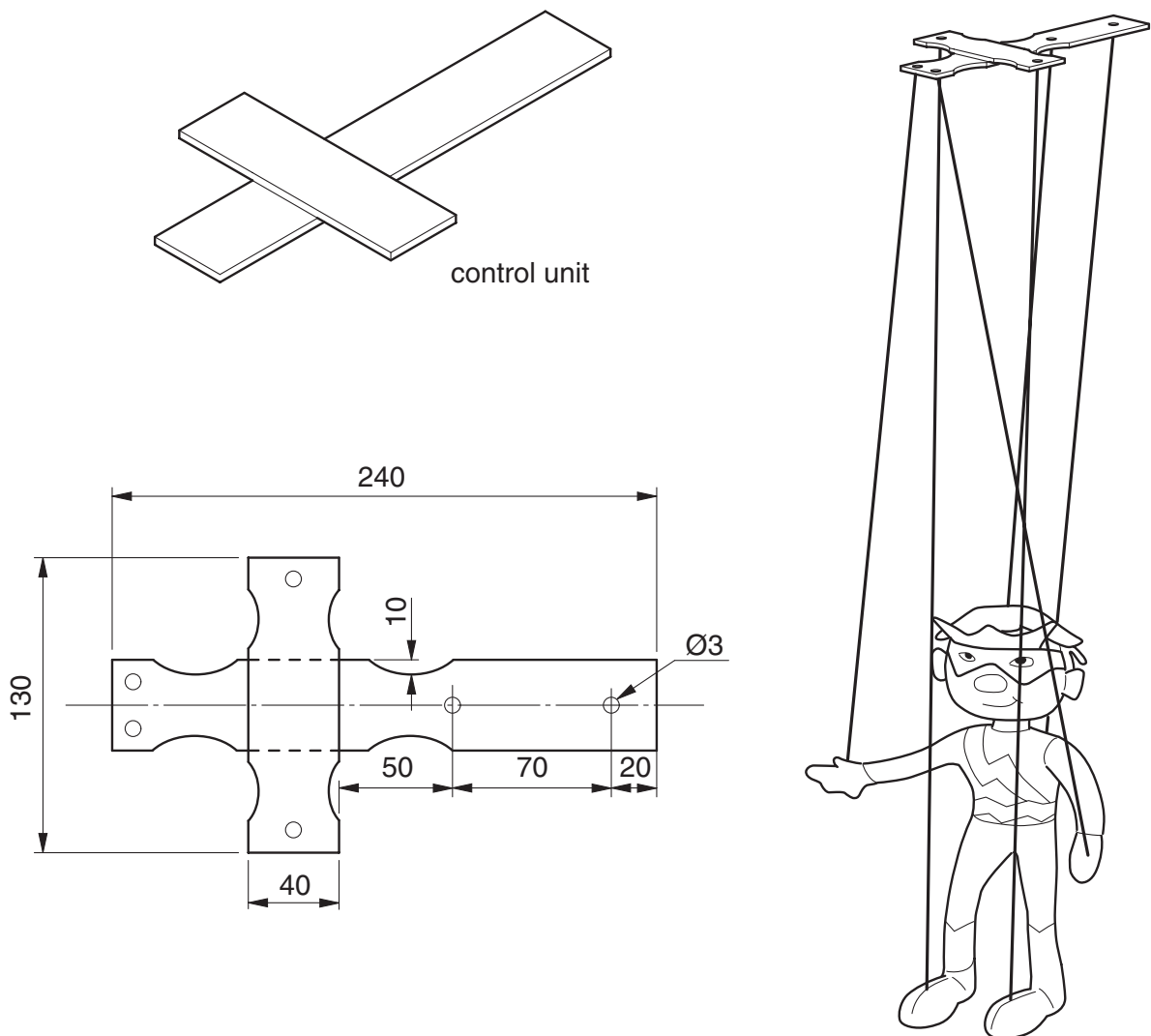

Fig. 6

- (a) State a suitable material for the control unit and sketch a method of joining that would allow the two parts to pivot. [3]
- (b) For the construction method you have given in answer to (a), use notes and sketches to fully describe how to:
- (i) mark out the material;
 - (ii) drill the string holes;
 - (iii) cut to shape;
 - (iv) join the two parts together. [14]

15 The outline design of a kneeler / seat for a gardener is shown in Fig. 7.

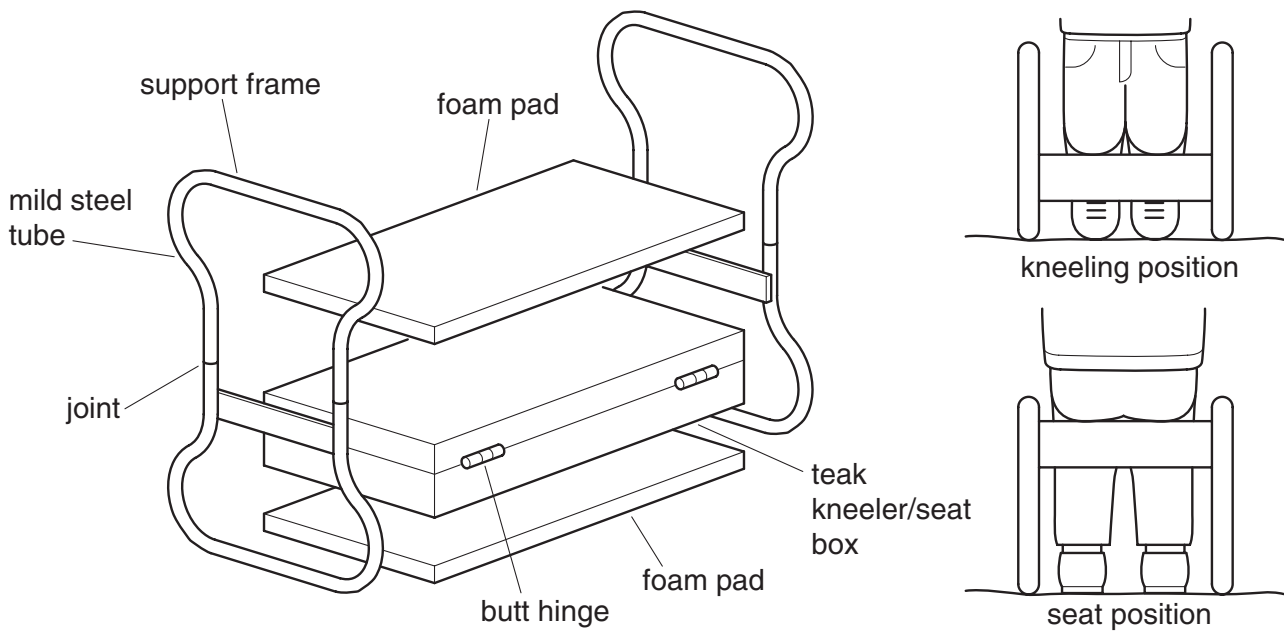

Fig. 7

(a) Describe, with the aid of notes and sketches, **two** of the following processes.

- (i) brazing the two parts of one of the mild steel support frames together
- (ii) fitting the butt hinges to the teak kneeler/seat box
- (iii) fitting and fixing one of the foam pads and a P.V.C. covering to the teak kneeler / seat box [2 × 7]

(b) Describe the application of a suitable finish for the mild steel support frame. [3]

- 16 Fig. 8 gives details of a teaching clock. It is made up of three main parts, a clock face, removable number discs and a support stand.

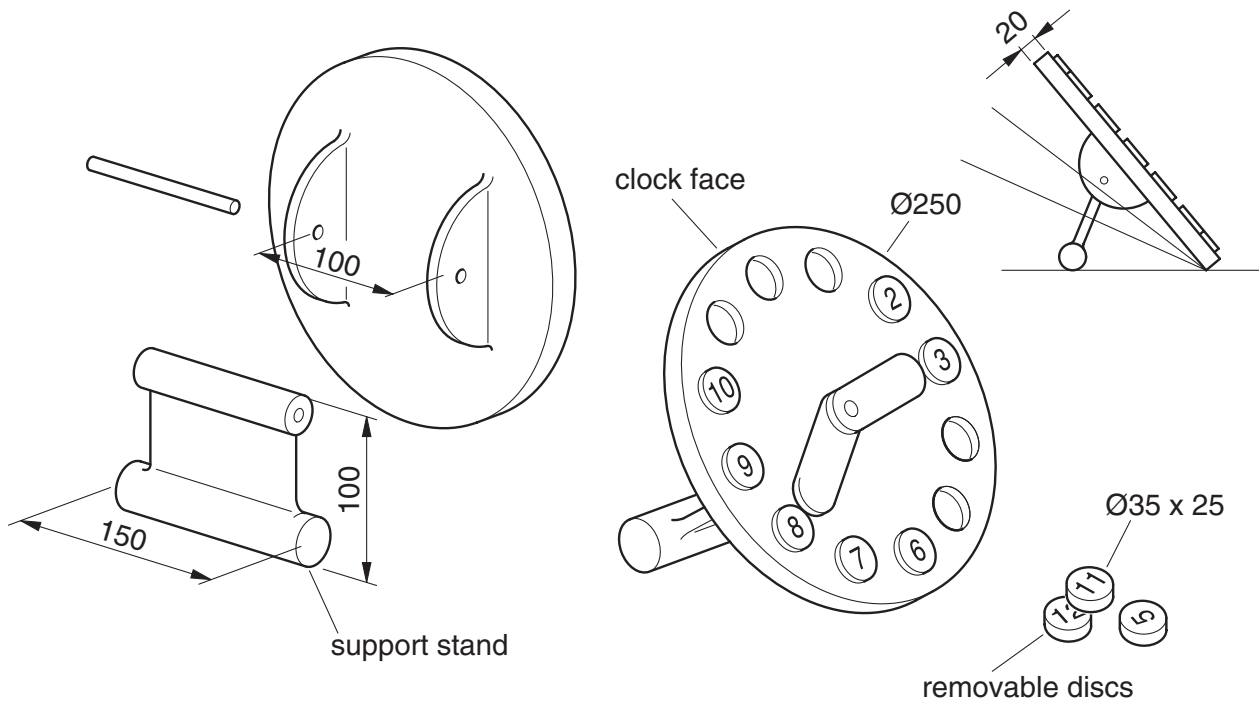

Fig. 8

- (a) Suggest a suitable material for the clock face and state the reason for your choice. [2]
- (b) Using notes and sketches, describe a method of manufacturing the clock face using the material given in answer to (a). [8]
- (c) Using a material of your own choice, describe a simple method of producing the removable discs. [The numbers are not required] [3]
- (d) With the aid of sketches, show how the support stand could be made to support the clock face at different angles. [4]

17 Fig. 9 shows three blanks and the resulting items to be produced by lathe work.

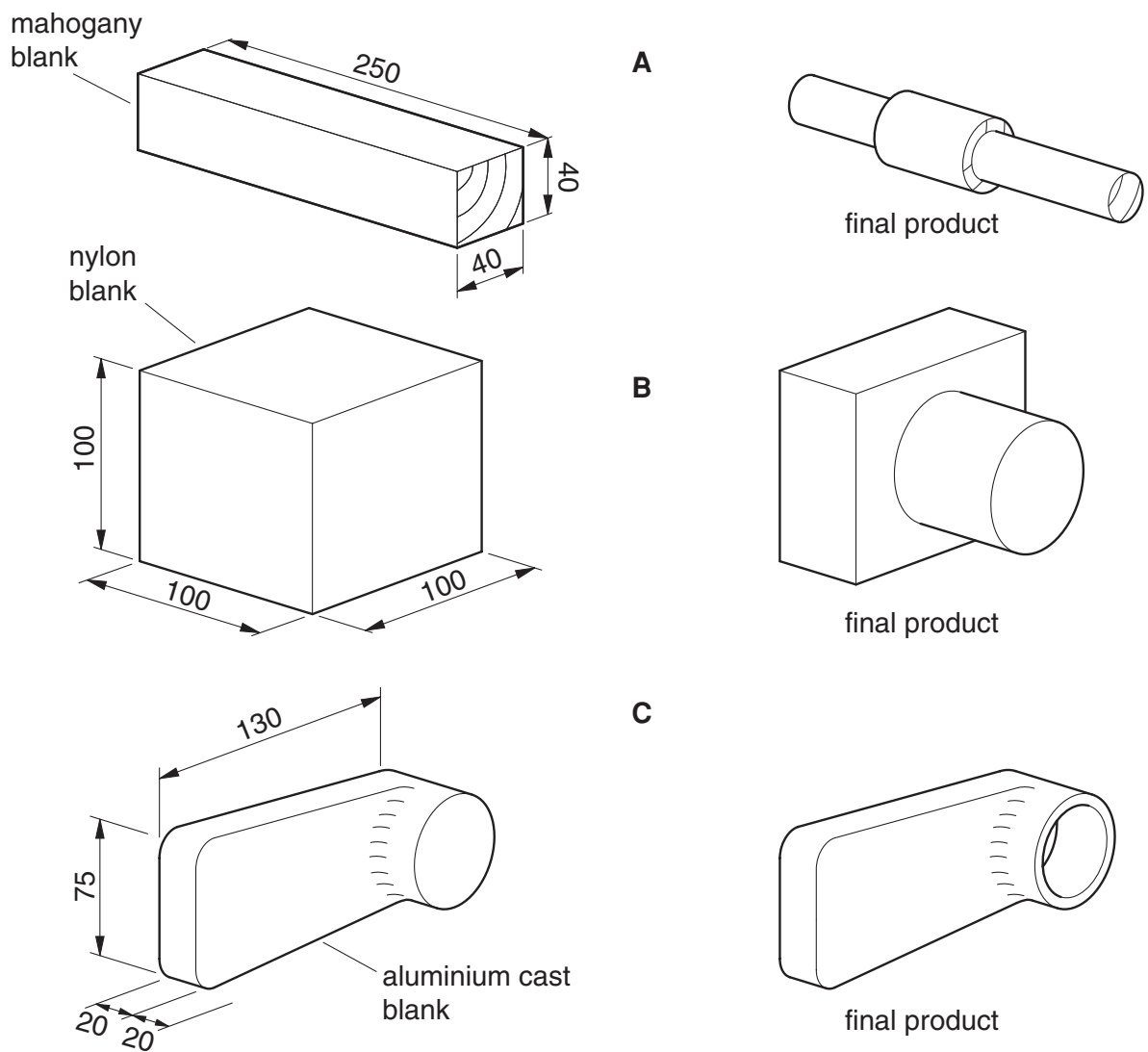

Fig. 9

- (a) State a suitable method of holding **each** blank on a lathe. [3]
- (b) With the aid of notes and sketches, describe **two** of the following stages in making the final shapes.
- (i) preparing the mahogany blank **A** ready for holding
 - (ii) setting the nylon blank **B** at centre height for turning
 - (iii) holding and balancing the aluminium cast blank **C** ready for boring [14]

18 Fig. 10 shows the outline design for a scissor storage rack.

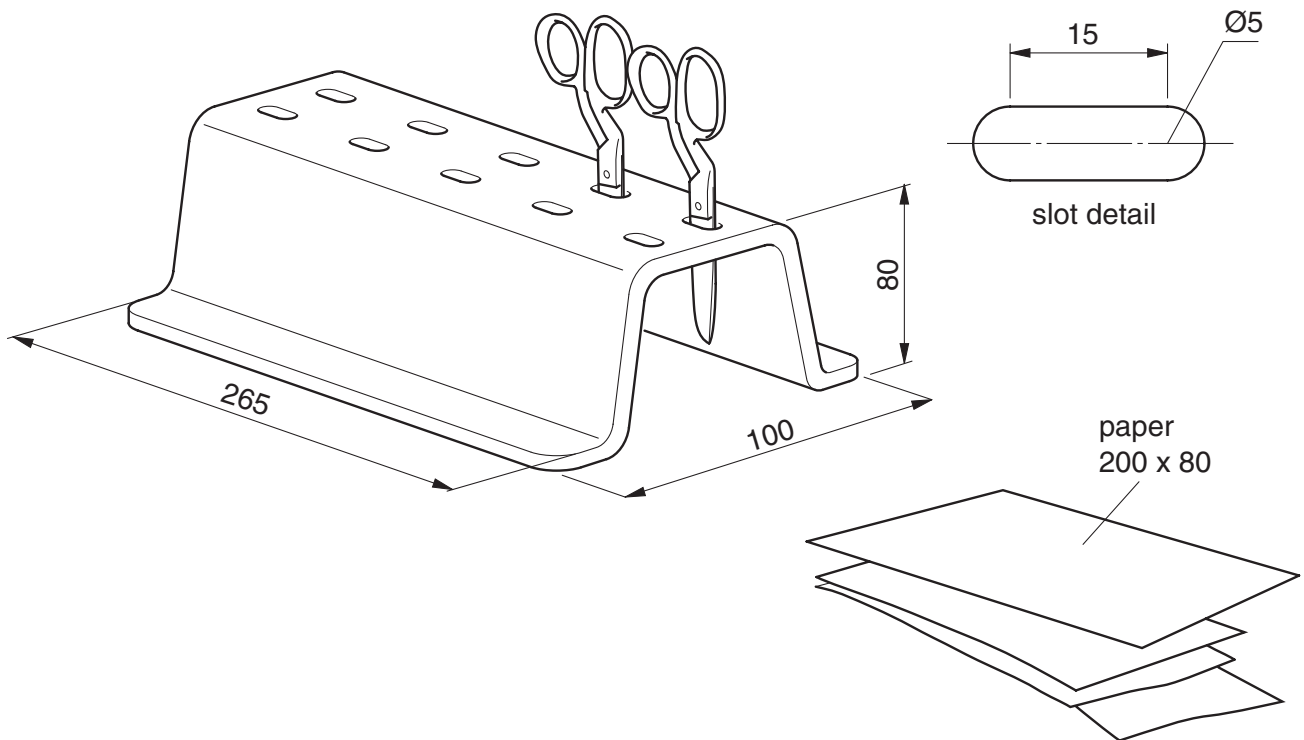

Fig. 10

- (a) State **two** properties of a suitable material for the scissor rack. [2]
- (b) Sketch the outline flat shape of the rack, after marking out, prior to cutting and shaping. [3]
- (c) Using notes and sketches describe how, from a flat material of your own choice,
- (i) the scissor slots are cut out,
 - (ii) the final shape is formed. [10]
- (d) Show by means of a design sketch, how the rack could be modified to hold the sheets of paper shown. [2]

Permission to reproduce items where third-party owned material protected by copyright is included has been sought and cleared where possible. Every reasonable effort has been made by the publisher (UCLES) to trace copyright holders, but if any items requiring clearance have unwittingly been included, the publisher will be pleased to make amends at the earliest possible opportunity.

University of Cambridge International Examinations is part of the University of Cambridge Local Examinations Syndicate (UCLES), which is itself a department of the University of Cambridge.