



UNIVERSITY OF CAMBRIDGE INTERNATIONAL EXAMINATIONS
General Certificate of Education Ordinary Level

CANDIDATE
NAME

CENTRE
NUMBER

--	--	--	--	--

CANDIDATE
NUMBER

--	--	--	--



COMBINED SCIENCE

5129/02

Paper 2

May/June 2009

2 hours 15 minutes

Candidates answer on the Question Paper.

No Additional Materials are required.

READ THESE INSTRUCTIONS FIRST

Write your Centre number, candidate number and name on all the work you hand in.

Write in dark blue or black pen.

You may use a soft pencil for any diagrams, graphs or rough working.

Do not use staples, paper clips, highlighters, glue or correction fluid.

DO NOT WRITE IN ANY BARCODES.

Answer **all** questions.

A copy of the Periodic Table is printed on page 24.

At the end of the examination, fasten all your work securely together.

The number of marks is given in brackets [] at the end of each question or part question.

For Examiner's Use

--

This document consists of **22** printed pages and **2** blank pages.



1 Study the following reaction scheme.

For
Examiner's
Use

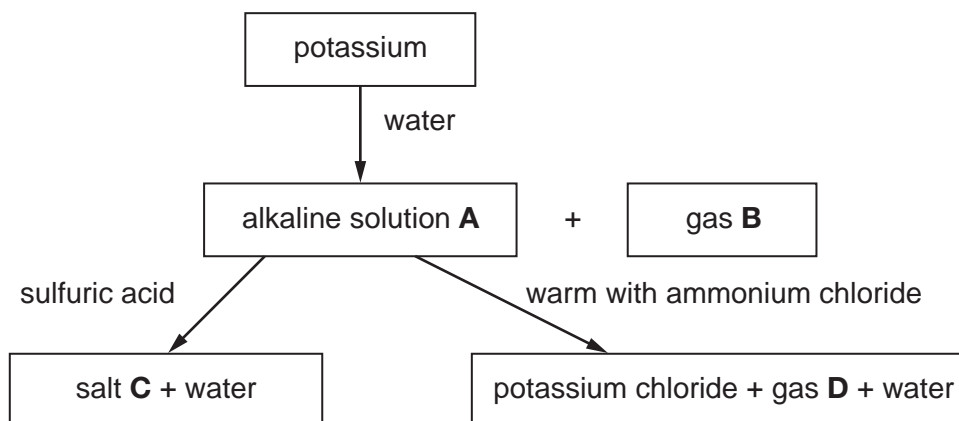

(a) Identify substances **A**, **B**, **C** and **D**.

alkaline solution **A**

gas **B**

salt **C**

gas **D**

[4]

(b) Name the ion present in solution **A** that makes it alkaline.

.....[1]

(c) Universal Indicator is added to solution **A**.
State its final colour.

.....[1]

- 2 A stone has a mass of 2.0 kg.
The gravitational field strength, g , on the Earth's surface is 10 N/kg.

For
Examiner's
Use

- (a) Calculate the weight of the stone on the Earth's surface.

weight = N [1]

- (b) On the Moon, the gravitational field strength is less than on the Earth. The stone is taken to the Moon.
State the change, if any, in

(i) the mass of the stone,

(ii) the weight of the stone.

[2]

- 3 An electromagnet and a piece of soft iron are shown in Fig. 3.1.

For
Examiner's
Use

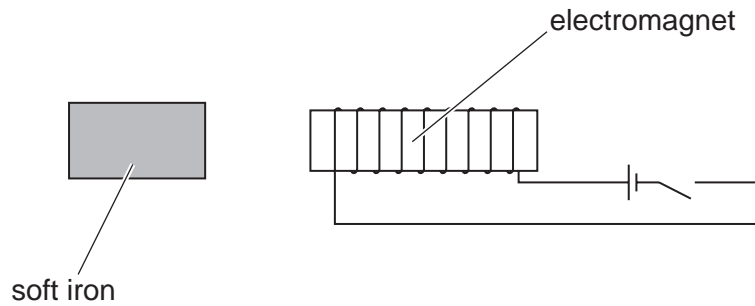

Fig. 3.1

- (a) When the current in the electromagnet is switched on, the soft iron is attracted. The current in the electromagnet is reversed. State the effect, if any, on the attraction of the soft iron.

.....
 [1]

- (b) Electromagnet cores are usually made of soft iron rather than steel. State the difference between the magnetic properties of soft iron and steel.

.....
 [2]

4 (a) Define *osmosis*.

.....
.....
..... [2]

(b) How does osmosis result in the uptake of water by plants?

.....
..... [1]

(c) An area of farmland has been flooded with seawater.

Suggest and explain the effect of this flooding on the crops growing on this land.

.....
.....
..... [2]

5 The following is a list of metals.

aluminium calcium copper iron zinc

*For
Examiner's
Use*

(a) From the list, select the metal that

(i) is protected from corrosion by an oxide layer,

.....

[1]

(ii) forms an amphoteric oxide,

.....

[1]

(iii) is a catalyst in the manufacture of ammonia.

.....

[1]

(b) Which metals are mixed together to form brass?

..... and

[2]

- 6 The displacement of particles in wave **X** varies with distance along the wave as shown in Fig. 6.1.

For
Examiner's
Use

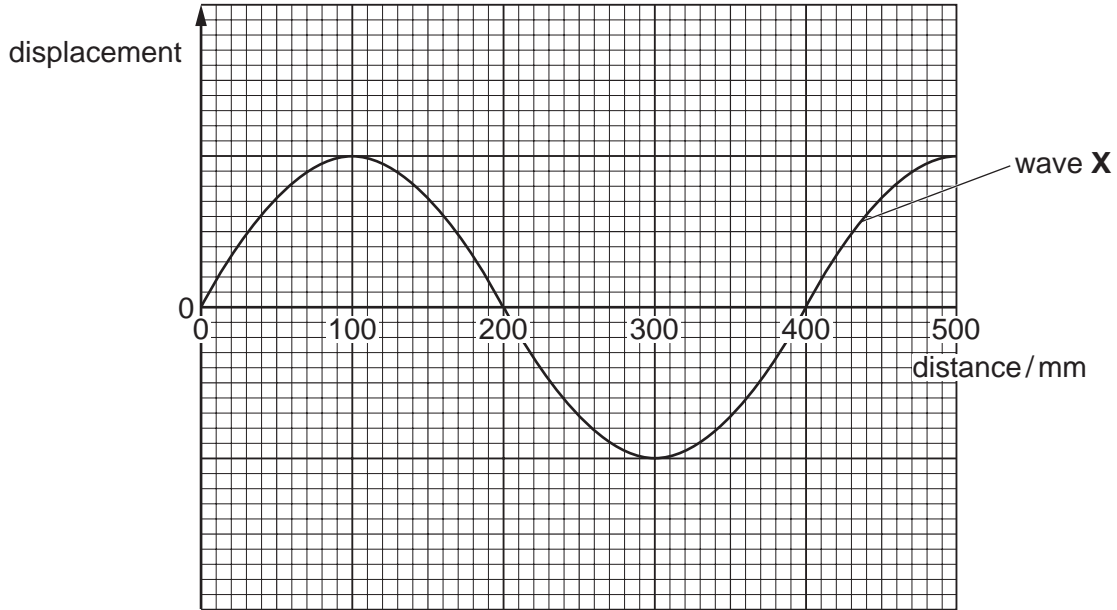

Fig. 6.1

- (a) Use Fig. 6.1 to determine the wavelength of wave **X**. mm [1]
- (b) A second wave, **Y**, has the same wavelength as wave **X** and half the amplitude.
On Fig. 6.1, draw a line to show how the displacement of wave **Y** varies with distance. [1]
- (c) (i) State the unit of frequency.
..... [1]
- (ii) A wave has a speed of 340m/s and a wavelength of 1.7 m.
Calculate the frequency of this wave.

frequency = [2]

7 Some red blood cells, as seen through a microscope, are shown in Fig. 7.1.

For
Examiner's
Use

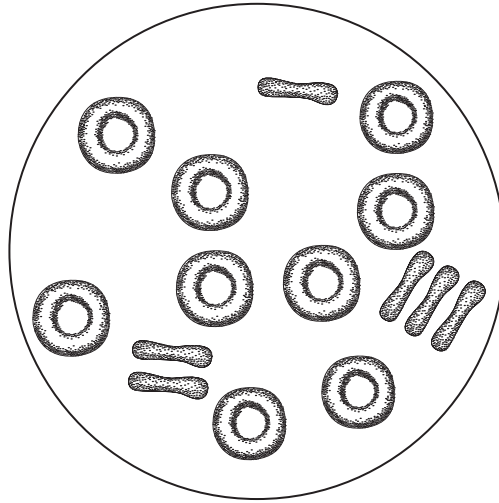

Fig. 7.1

(a) (i) Name **one** structure, normally present in cells, that is **not** present in red blood cells.

.....[1]

(ii) Name two other structures, **not** present in these cells, that would normally be present in **plant cells**.

1.

2.[2]

(b) Blood also contains white blood cells, platelets and plasma.

State one function of

(i) white blood cells,

(ii) platelets,

(iii) plasma.

[3]

- 8 Apparatus used to react magnesium with steam is shown in Fig. 8.1.

For
Examiner's
Use

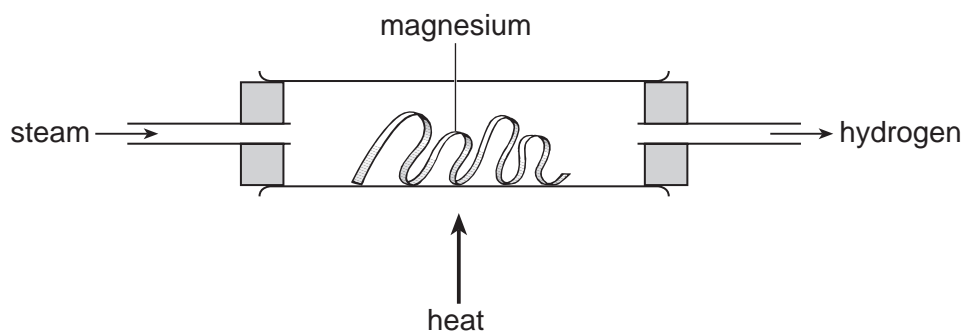
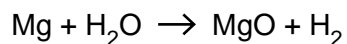

Fig. 8.1

The equation for the reaction is



- (a) What does the reaction tell you about the relative reactivity of magnesium and hydrogen?

.....[1]

- (b) Describe a test to show that the gas produced is hydrogen.

test

result[2]

- (c) State **one** large-scale use of hydrogen.

.....[1]

- (d) (i) Calculate the relative molecular mass of magnesium oxide.
(A_r : Mg, 24; O, 16.)

.....[1]

- (ii) Calculate the mass of magnesium oxide produced when 1.8 g of magnesium is reacted with excess steam.

mass = g [2]

- 9 Fig. 9.1 shows two resistors, **P** and **Q**, in series.

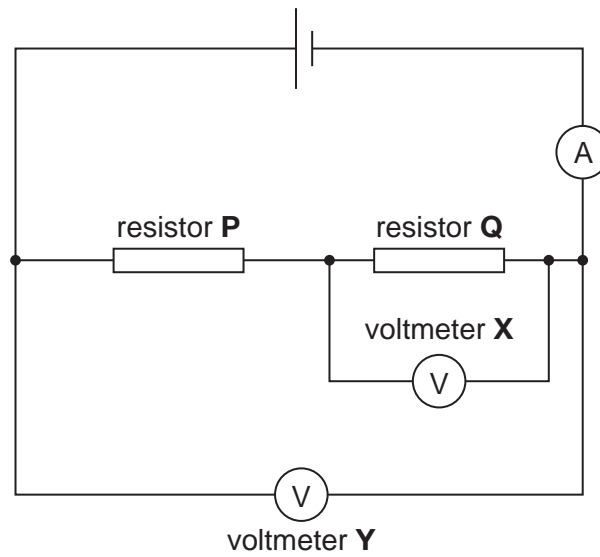

Fig. 9.1

The ammeter reads 0.20 A. Voltmeter **X** reads 1.2 V and voltmeter **Y** reads 2.0 V.

- (a) Calculate the potential difference across resistor **P**.

potential difference = V [1]

- (b) Calculate the resistance of resistor **Q**.

resistance = Ω [2]

- (c) Calculate the charge passing through the ammeter in 2 minutes.

charge = unit [3]

10 (a) A balanced diet contains sufficient quantities of protein, carbohydrate, fat, fibre and water.

(i) Name two other different essential components of a balanced diet.

1.

2. [2]

(ii) Explain the importance of fibre in the diet.

.....

..... [1]

(b) Food provides the energy needed by the body.

The energy taken in and used by three people is shown in Fig. 10.1.

	average daily energy intake/kJ	average daily energy used/kJ
Rajiv	9700	9700
Kapilisha	6800	6850
Sanjay	10500	9600

Fig. 10.1

(i) Give a possible reason for the difference in the amounts of energy used by Rajiv and Kapilisha.

.....

..... [1]

(ii) Sanjay continues to eat the same diet for many years. Suggest a likely effect of this diet on his health.

.....

..... [1]

11 A barrel of gunpowder is shown in Fig. 11.1.

For
Examiner's
Use

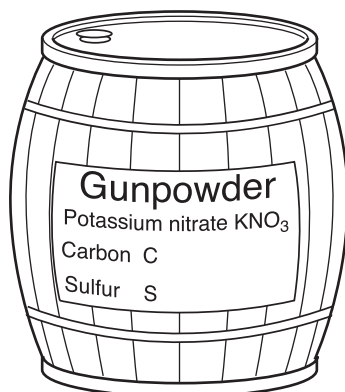

Fig. 11.1

Gunpowder is a mixture of carbon, sulfur and potassium nitrate.
Carbon and sulphur are insoluble in water. Potassium nitrate is soluble in water.

Describe how you would obtain a sample of solid potassium nitrate from the gunpowder.

.....

.....

.....

..... [3]

12 An unmarked liquid-in-glass thermometer is shown in Fig. 12.1.

For
Examiner's
Use

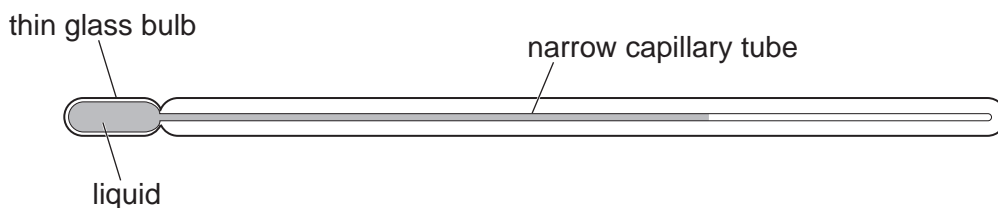

Fig. 12.1

(a) The thermometer is to have a scale marked on it.
Explain why the thermometer is placed in melting ice and then placed in boiling water.

.....

 [2]

(b) State **one** change that could be made to the capillary tube to make a liquid-in-glass thermometer more sensitive.

.....
 [1]

(c) The volume of the liquid in the thermometer changes with change in temperature.
Name **one** physical property of matter, other than volume, that also changes with change in temperature.

..... [1]

13 The graph shows the number of adults with HIV/AIDS in sub-Saharan Africa between 1985 and 2005.

For
Examiner's
Use

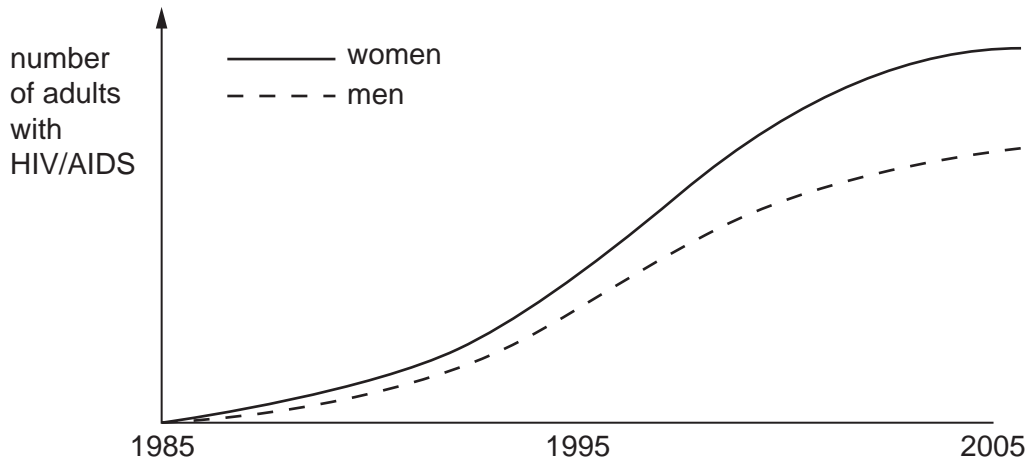

(a) State three trends shown by the graph.

- 1.
.....
- 2.
.....
- 3.
..... [3]

(b) Suggest two ways by which the spread of HIV/AIDS may be reduced.

- 1.
.....
- 2.
..... [2]

(c) State why the abuse of heroin may contribute to the spread of HIV/AIDS.

-
..... [1]

- 14 An atom of fluorine is represented by ${}^{19}_{9}\text{F}$.
The numbers 19 and 9 provide information about the structure of this fluorine atom.

For
Examiner's
Use

- (a) (i) Complete the following sentences.

The number 19 is the number of fluorine.

The number 9 is the number of fluorine.

[2]

- (ii) Fluorine is a non-metal.
How can this be deduced from the symbol ${}^{19}_{9}\text{F}$?

.....
.....
..... [2]

- (iii) Complete Fig. 14.1 to show the electronic structure of fluorine.

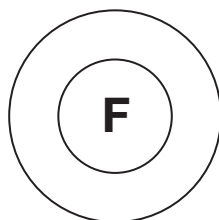

Fig. 14.1

[1]

- (b) Fluorine reacts violently with sodium to produce a white substance.

- (i) State the name of the substance produced.

.....

- (ii) State the type of bonding present in this substance.

.....

[2]

15 Radioactive sources may emit alpha-particles, beta-particles or gamma-rays from the nucleus.

(a) Name apparatus that is used to detect alpha-particles.

.....[1]

(b) State which of alpha-particles, beta-particles or gamma-rays are

(i) the most penetrating,

(ii) the most ionising,

(iii) electrons.

[3]

16 An electric iron is shown in Fig. 16.1.

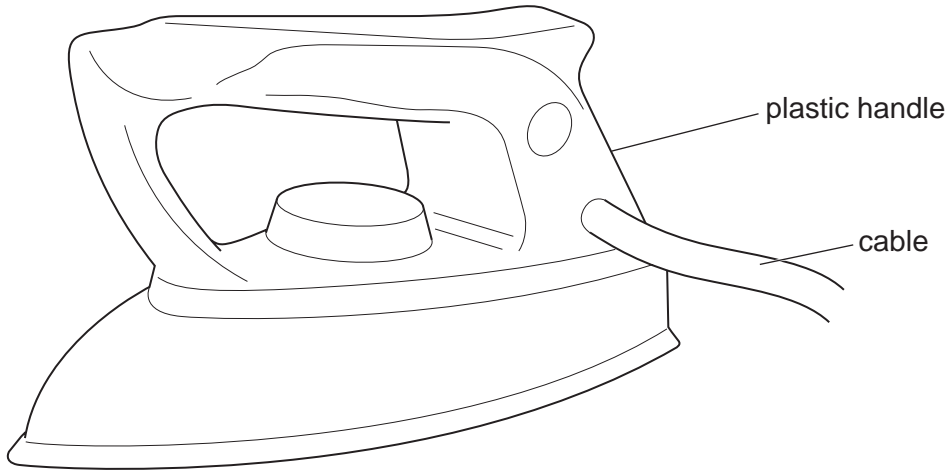

Fig. 16.1

The iron is rated as 2000W.

(a) Calculate the amount of electrical energy changed into heat energy by the iron in 20 minutes.

energy = unit [3]

(b) The insulation of the cable may become damaged.
State and explain why this is hazardous.

.....
..... [2]

17 Human activities are destroying the Amazonian rainforest at a rate of about 50 000 km² per year.

(a) Suggest two reasons why rainforests are being destroyed by human activities.

- 1.
.....
- 2.
..... [2]

(b) Suggest the possible harmful effects of deforestation on

- (i) the Earth's atmosphere,
.....
.....
- (ii) animals living in the area,
.....
.....
- (iii) the soil.
.....
..... [3]

18 Ethene, C₂H₄, is made by decomposing a long-chain hydrocarbon over a hot catalyst.

For
Examiner's
Use

(a) (i) Name the process used to decompose this hydrocarbon.

..... [1]

(ii) One of these hydrocarbons is octane.

Complete the equation for the decomposition of octane.

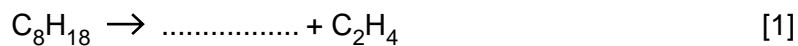

(iii) Draw the structure of ethene.

[1]

(b) Ethanol, C₂H₅OH, is made industrially from ethene.

Name the substance added to ethene to make ethanol.

..... [1]

(c) State **one** use of ethanol. [1]

- 19 A ray of light is incident at an angle of 28° on a water surface as shown in Fig. 19.1.

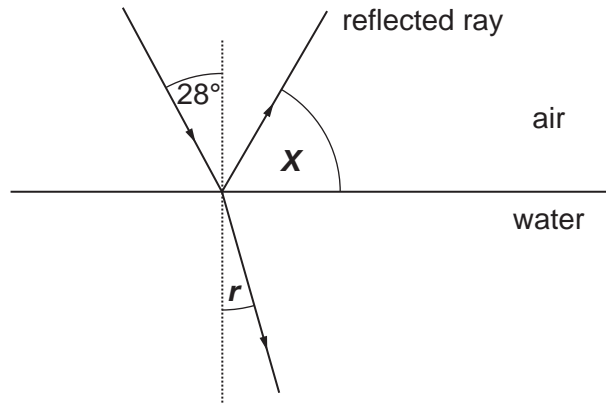

Fig. 19.1

The light is partly reflected and partly refracted.

- (a) Calculate angle X .

$$X = \dots\dots\dots^\circ \quad [1]$$

- (b) The refractive index of the water is 1.33. The angle of incidence is 28° . Calculate the angle of refraction r .

$$\text{angle} = \dots\dots\dots^\circ \quad [3]$$

20 A farmer analyses the nitrogen content of the soil in two of his fields.

The results of this analysis are shown in Fig. 20.1.

	nitrogen content (arbitrary units)
field A	135
field B	30
recommended level	120

Fig. 20.1

(a) Explain why plants need nitrogen.

.....
 [1]

(b) (i) The plants in field **B** do not grow well. In what other way would the appearance of the plants differ from normal?

..... [1]

(ii) How could the nitrogen content of field **B** be increased to the recommended level?

..... [1]

(c) In many parts of the world, not enough food is produced to feed everyone.

(i) Suggest **one** reason why this problem has become worse over the past 100 years.

.....
 [1]

(ii) To feed a large number of people, it is better to grow plant crops, rather than raising animals for meat.

Use ideas about food chains to explain why.

.....
 [2]

DATA SHEET
The Periodic Table of the Elements

		Group																			
I	II	III	IV	V	VI	VII	0														
1 H Hydrogen 1											2 He Helium 2										
3 Li Lithium 3	4 Be Beryllium 4	5 B Boron 5	6 C Carbon 6	7 N Nitrogen 7	8 O Oxygen 8	9 F Fluorine 9	10 Ne Neon 10					11 B Boron 11									
11 Na Sodium 11	12 Mg Magnesium 12	13 Al Aluminium 13	14 Si Silicon 14	15 P Phosphorus 15	16 S Sulfur 16	17 Cl Chlorine 17	18 Ar Argon 18					19 F Fluorine 19									
19 K Potassium 19	20 Ca Calcium 20	21 Sc Scandium 21	22 Ti Titanium 22	23 V Vanadium 23	24 Cr Chromium 24	25 Mn Manganese 25	26 Fe Iron 26	27 Co Cobalt 27	28 Ni Nickel 28	29 Cu Copper 29	30 Zn Zinc 30	31 Ga Gallium 31	32 Ge Germanium 32	33 As Arsenic 33	34 Se Selenium 34	35 Br Bromine 35	36 Kr Krypton 36				
37 Rb Rubidium 37	38 Sr Strontium 38	39 Y Yttrium 39	40 Zr Zirconium 40	41 Nb Niobium 41	42 Mo Molybdenum 42	43 Tc Technetium 43	44 Ru Ruthenium 44	45 Rh Rhodium 45	46 Pd Palladium 46	47 Ag Silver 47	48 Cd Cadmium 48	49 In Indium 49	50 Sn Tin 50	51 Sb Antimony 51	52 Te Tellurium 52	53 I Iodine 53	54 Xe Xenon 54				
55 Cs Caesium 55	56 Ba Barium 56	57 La Lanthanum 57	72 Hf Hafnium 72	73 Ta Tantalum 73	74 W Tungsten 74	75 Re Rhenium 75	76 Os Osmium 76	77 Ir Iridium 77	78 Pt Platinum 78	79 Au Gold 79	80 Hg Mercury 80	81 Tl Thallium 81	82 Pb Lead 82	83 Bi Bismuth 83	84 Po Polonium 84	85 At Astatine 85	86 Rn Radon 86				
87 Fr Francium 87	88 Ra Radium 88	89 Ac Actinium 89																			
												162 Dy Dysprosium 66	165 Ho Holmium 67	167 Er Erbium 68	169 Tm Thulium 69	173 Yb Ytterbium 70	175 Lu Lutetium 71				
												159 Tb Terbium 65	157 Gd Gadolinium 64	152 Eu Europium 63	150 Sm Samarium 62	147 Pm Promethium 61	144 Nd Neodymium 60	141 Pr Praseodymium 59	140 Ce Cerium 58		
												247 Bk Berkelium 97	247 Cm Curium 96	243 Am Americium 95	244 Pu Plutonium 94	237 Np Neptunium 93	238 U Uranium 92	231 Pa Protactinium 91	232 Th Thorium 90		
												257 Fm Fermium 100	252 Es Einsteinium 99	257 Md Mendelevium 101	259 No Nobelium 102	260 Lr Lawrencium 103					

* 58–71 Lanthanoid series
† 90–103 Actinoid series

Key

a	X
b	

a = relative atomic mass
X = atomic symbol
b = atomic (proton) number

The volume of one mole of any gas is 24 dm³ at room temperature and pressure (r.t.p.).