

UNIVERSITY OF CAMBRIDGE INTERNATIONAL EXAMINATIONS
General Certificate of Education Ordinary Level

COMBINED SCIENCE

Paper 2



5129/02

October/November 2006

2 hours 15 minutes

Candidates answer on the Question Paper.
No Additional Materials are required.

Candidate
Name

--

Centre
Number

--	--	--	--	--

Candidate
Number

--	--	--	--

READ THESE INSTRUCTIONS FIRST

Write your Centre number, candidate number and name on all the work you hand in.
Write in dark blue or black pen.
You may use a soft pencil for any diagrams, graphs or rough working.
Do not use staples, paper clips, highlighters, glue or correction fluid.

Answer **all** questions.
A copy of the Periodic Table is printed on page 20.
At the end of the examination, fasten all your work securely together.
The number of marks is given in brackets [] at the end of each question or part question.

For Examiner's Use

--

This document consists of **20** printed pages.



1 Fig. 1.1 shows a ray of light entering and passing through a parallel-sided plastic block.

For
Examiner's
Use

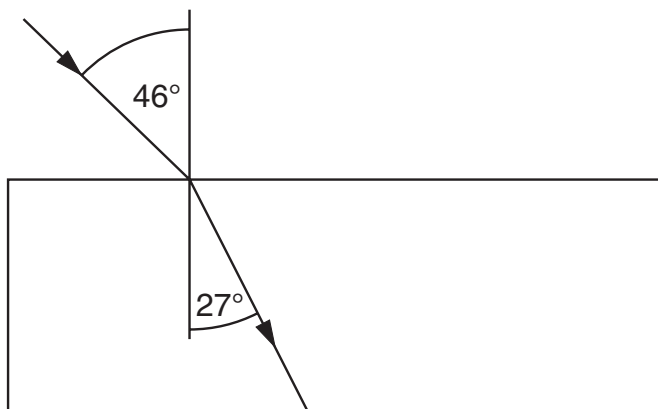

Fig. 1.1

- (a) On Fig. 1.1 draw an arrow to show the path of the ray after it has left the plastic block. [2]
- (b) Calculate the refractive index of the plastic.

[2]

2 (a) What type of substance are all enzymes?

..... [1]

(b) State the effect of the enzyme amylase on the conversion of starch to maltose.

..... [1]

(c) Explain two ways in which chewing a piece of bread helps the process of digestion.

1.

.....

2.

..... [2]

3 Air is a mixture of gases.
This mixture includes the noble gases helium and argon.

(a) Helium is used to fill airships and balloons.

State two reasons why helium is a good choice for this use.

- 1.
- 2. [2]

(b) Argon is used to fill light bulbs.

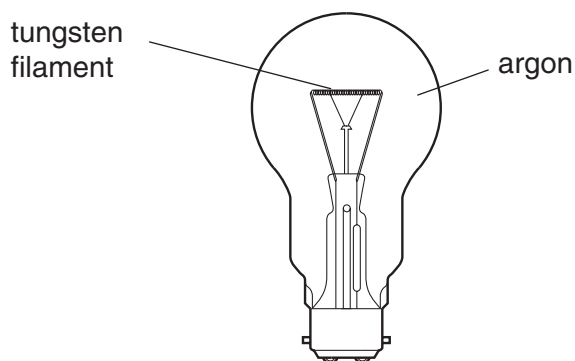

(i) Why are light bulbs **not** filled with air?

-
-
- [2]

(ii) Use your knowledge of the electronic structure of argon to explain why it is a good choice to fill light bulbs.

-
-
- [2]

- 4 Fig. 4.1 represents a hydroelectric power station. Water flows from an upper lake to a lower lake to generate electrical energy.

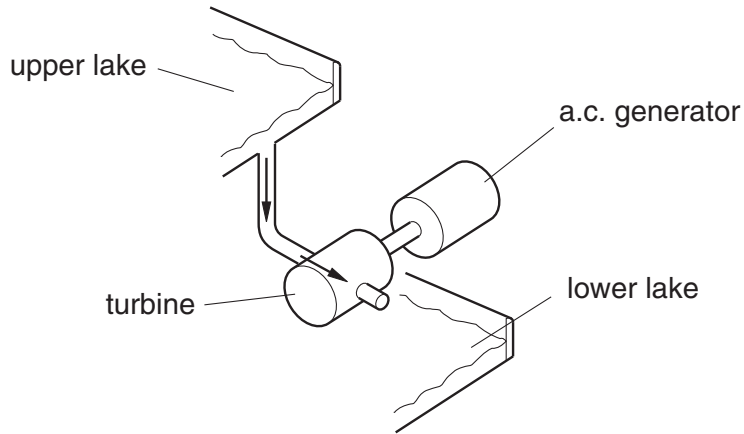

Fig. 4.1

- (a) Name the type of energy lost by the water

(i) as it falls from the upper lake,

.....energy [1]

(ii) as it slows down in the turbine.

.....energy [1]

- (b) Complete Fig. 4.2 to show how the voltage output of a simple a.c. generator varies with time.



Fig. 4.2

[2]

- (c) A small generator has an output of 20 W.
Calculate how much electrical energy is produced in 3 minutes.

*For
Examiner's
Use*

[3]

5 Hydrochloric acid is a strong acid which turns Universal Indicator red.

(a) (i) Name the ion present in hydrochloric acid which causes acidity.

.....[1]

(ii) Suggest the pH of hydrochloric acid.

.....[1]

(b) A student adds hydrochloric acid to calcium carbonate. The colourless gas produced passes through limewater as shown in Fig. 5.1.

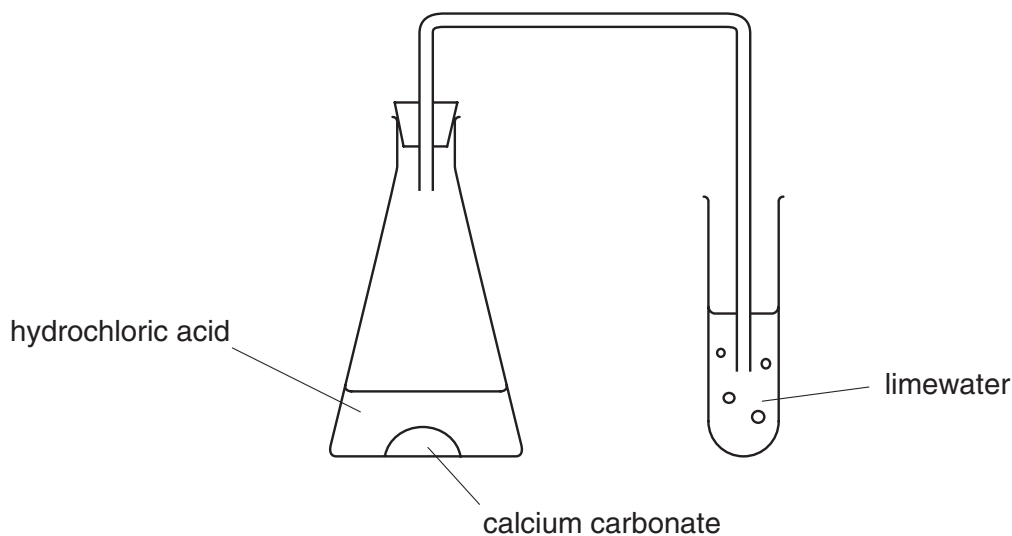

Fig. 5.1

(i) Describe the change in appearance of the limewater as the colourless gas passes through it.

.....[1]

(ii) Name this gas that is produced during the reaction of hydrochloric acid and calcium carbonate.

.....[1]

(iii) Suggest the name of the salt produced by the reaction between hydrochloric acid and calcium carbonate.

.....[1]

6 Fig. 6.1 shows an external view of the heart.

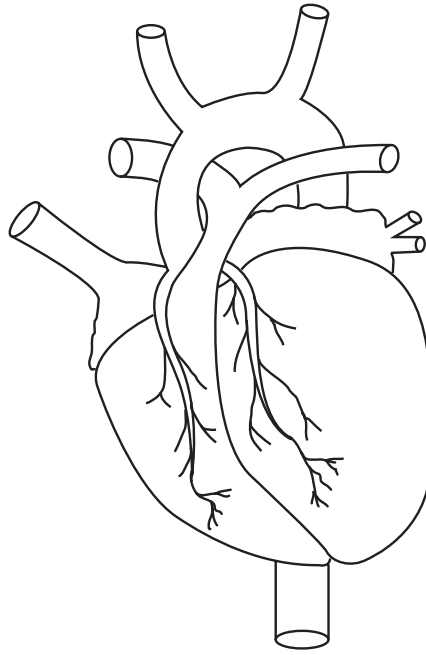

Fig. 6.1

(a) (i) Name the tissue that is supplied with blood by the coronary arteries.

.....[1]

(ii) Suggest three substances that the blood supplies to this tissue.

1.

2.

3.[3]

(b) A person's diet may cause them to suffer from coronary heart disease.

(i) Name a substance in a diet that may cause coronary heart disease.

.....[1]

(ii) State the change in the coronary arteries that leads to coronary heart disease.

.....

.....[1]

(iii) State **one** other cause of coronary heart disease.

.....

.....[1]

- 7 The car in Fig. 7.1 has a mass of 840 kg.

For
Examiner's
Use

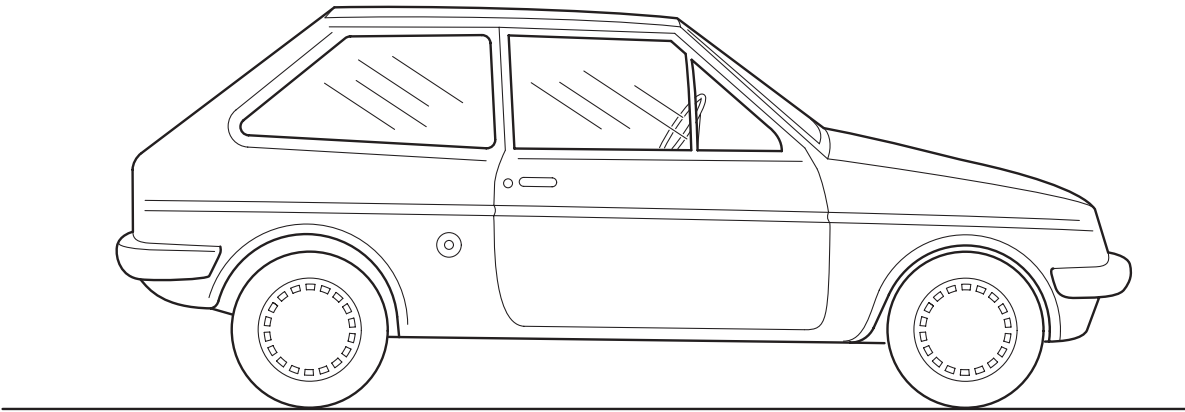

Fig. 7.1

- (a) The gravitational field strength g on Earth is 10 N/kg .
Calculate the weight of the car.

[2]

- (b) The force produced by the engine that accelerates the car is 2100 N .
Calculate the acceleration of the car.

[3]

8 Atoms are made up of three types of particle.

- (a) (i) Complete the table to show the relative mass and the relative charge of each of these three types of particle.

particle	relative mass	relative charge
proton		+1
electron	$\frac{1}{1840}$	
neutron	1	

[3]

- (ii) Define the term *nucleon number* (mass number).

.....
[1]

- (b) Bromine is element 35 in the periodic table.
 An atom of an isotope of bromine contains 35 protons, 35 electrons and 44 neutrons.
 The atom is represented by



Deduce the values of **A** and **Z**.

A

Z

[2]

9 Fig. 9.1 is a circuit diagram for the headlamps of a car. **P** and **Q** are identical lamps.

For
Examiner's
Use

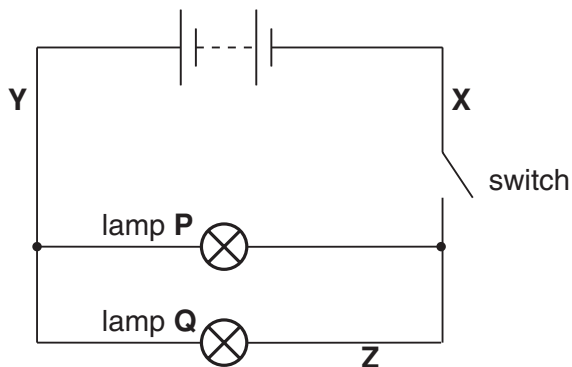

Fig. 9.1

(a) On Fig. 9.1, draw the symbol for a voltmeter that is connected into the circuit so that the voltage across lamp **Q** may be measured. [2]

(b) The switch is closed. The current in lamp **Q** is 3.0 A and the potential difference across it is 12 V.

(i) Calculate the resistance of the lamp.

[3]

(ii) Determine the current at

X, A

Y, A

Z, A

[3]

(c) Suggest why the lamps are connected in parallel rather than in series.

.....
.....[1]

10 Fig. 10.1 shows the structures of four organic compounds, **A**, **B**, **C** and **D**.

For
Examiner's
Use

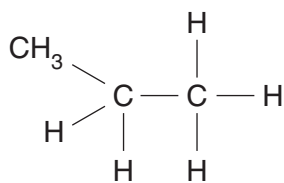
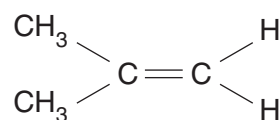
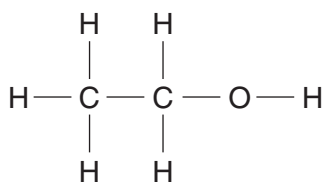
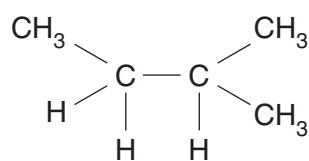
**A****B****C****D****Fig. 10.1**

(a) Which compound is

(i) an alkene,

(ii) an alcohol,

(iii) oxidised to a carboxylic acid?

[3]

(b) Two of the compounds are alkanes.

Which of these two alkanes has the higher boiling point?

[1]

(c) All four compounds burn in excess oxygen to give the same two products.

State the names of these two products.

..... and

[2]

- 11 Fig. 11.1 shows a plant in a pot of damp soil on a balance. The pot and the soil are covered by a plastic bag.

For
Examiner's
Use

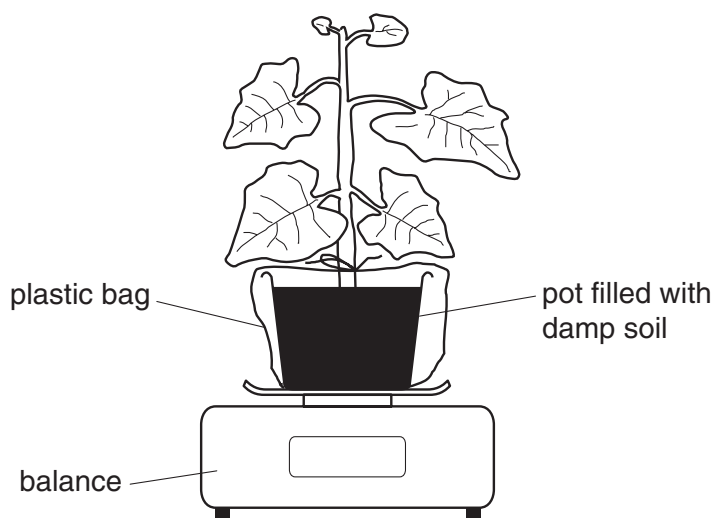

Fig. 11.1

- (a) During the next hour, the reading on the balance decreases.

- (i) Name the substance that is being lost from the plant.

.....[1]

- (ii) Name the structures in the leaves of the plant through which the substance is lost.

.....[1]

- (iii) Name the process that causes the decrease in mass.

.....[1]

- (b) (i) Describe how the appearance of the plant will alter if the apparatus in Fig. 11.1 is left on the balance for a week.

.....

.....[1]

- (ii) Explain your answer.

.....

.....

.....

.....[2]

12 The radioactive isotope strontium-90 emits beta-particles.

For
Examiner's
Use

(a) State the nature of a beta-particle. [1]

(b) State from which part of the atom the beta-particle is emitted. [1]

(c) Fig. 12.1 shows how the activity of a sample of strontium-90 varies with time.

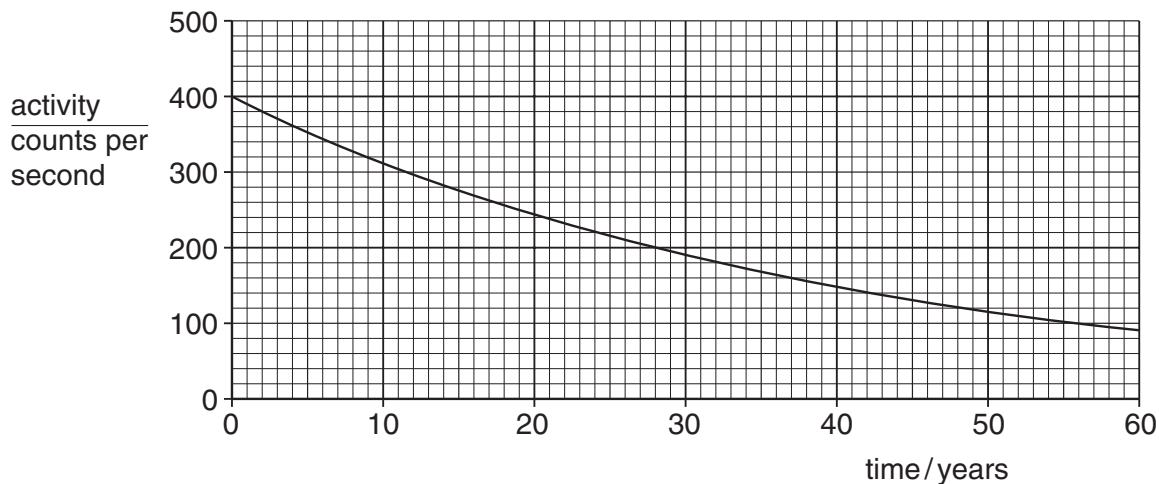

Fig. 12.1

Use Fig. 12.1 to determine the half-life of strontium-90.

half-life = years [1]

- 13** Magnesium is in Group II of the Periodic Table.
The electronic structure of magnesium is 2, 8, 2.

For
Examiner's
Use

- (a) (i) Draw a diagram showing the arrangement of the electrons in a magnesium **ion**.

[1]

- (ii) Write the formula of the magnesium ion.[1]

- (b) Fig. 13.1 shows magnesium burning in carbon dioxide.
The reaction produces a black solid (carbon) and a white solid (magnesium oxide).

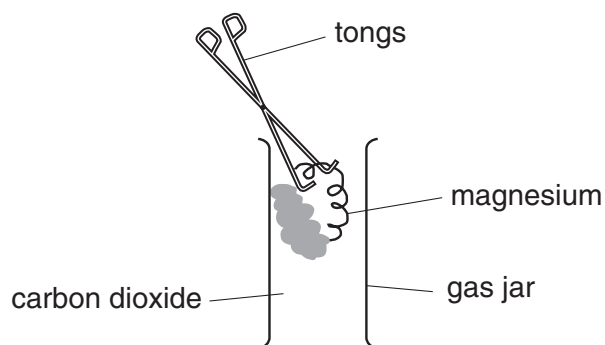
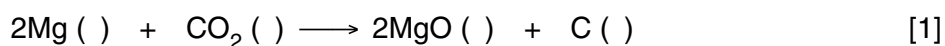

Fig. 13.1

- (i) Complete the equation for the reaction by adding the state symbols.



- (ii) Calculate the relative molecular mass of carbon dioxide.
[A_r : C,12; O,16.]

.....[1]

- (iii) Calculate the mass of magnesium that is required to react completely with 2.2 g of carbon dioxide.
[A_r : Mg,24.]

.....
.....[2]

- 14 (a) (i) Name the two types of cell that form a zygote during sexual reproduction.
1.
2. [2]

- (ii) When these two cells meet, their nuclei fuse.
- Name this process.
- [1]

(b) Fig. 14.1 shows part of the female reproductive and urinary systems.

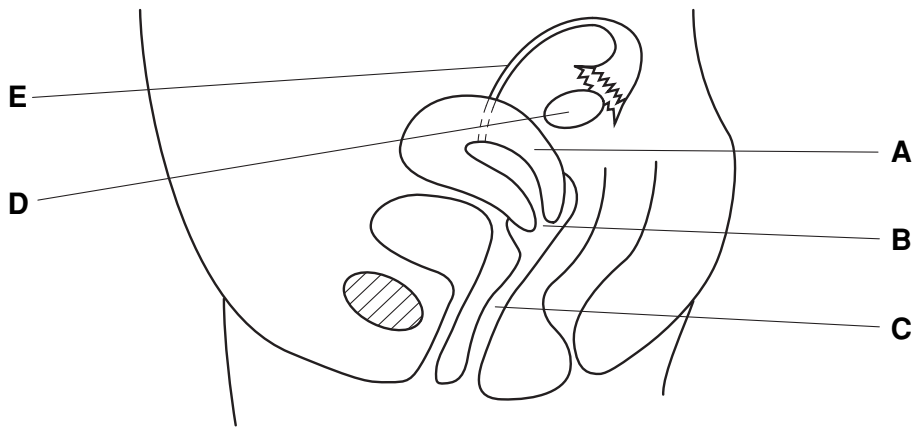

Fig. 14.1

- (i) Name the parts labelled
- A,
- B,
- C, [3]

- (ii) State the function of the parts labelled
- D,
-
- E,
- [2]

(c) On Fig. 14.1 mark an **X** where a zygote will develop. [1]

- 15 A road is made by laying slabs of concrete with gaps between them. Fig. 15.1 shows this road at low temperature.

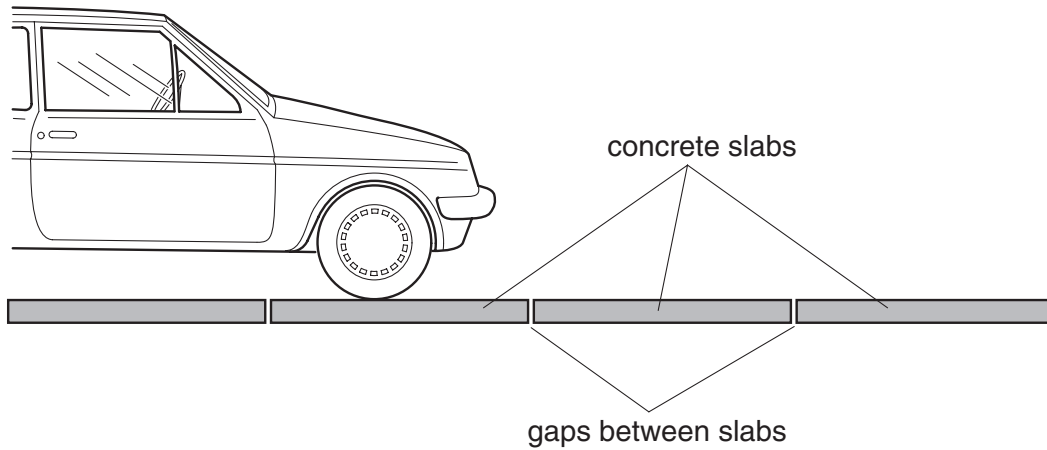

Fig. 15.1

- (a) The temperature increases.
Suggest what happens to
- (i) the concrete slabs,[1]
 - (ii) the gaps between the slabs.[1]
- (b) Another road is laid on a cold day with no gaps between the concrete slabs.
Suggest what may happen to this road on a very hot day.
-
-[1]

- 16** A small piece of each of four metals is placed in a separate test-tube containing dilute hydrochloric acid.

Results of this experiment are shown in Fig. 16.1.

For
Examiner's
Use

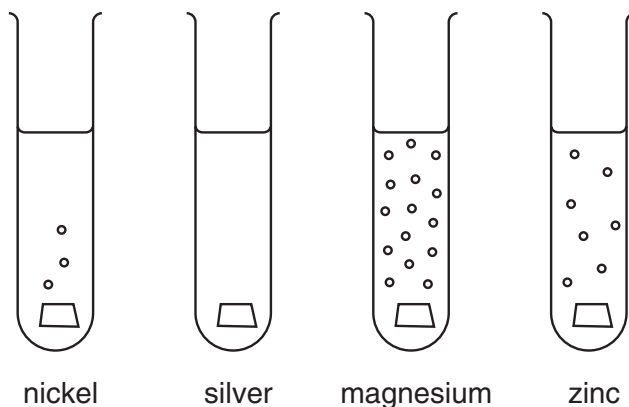

Fig. 16.1

- (a)** Use Fig. 16.1 to deduce the reactivity series of these metals.

most reactive

.....

.....

least reactive

[1]

- (b)** The reaction between a metal and an acid produces a salt and hydrogen.

- (i)** Draw a dot and cross diagram to show the bonding in a molecule of hydrogen.

[1]

- (ii)** Name the salt produced when magnesium reacts with hydrochloric acid.

.....[1]

- (iii)** State the type of bonding present in this salt.[1]

17 (a) The following words describe organisms found in a food chain.

carnivore decomposer herbivore producer

Write these words in the boxes in the order in which they occur in a food chain.

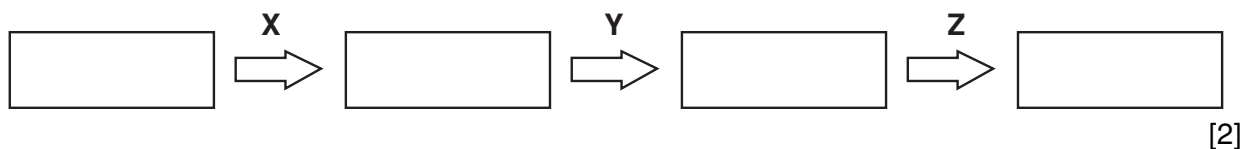

(b) (i) State the original source of the energy in a food chain.

.....[1]

(ii) Name the process that makes this energy available to the food chain.

.....[1]

(iii) Referring to the diagram in (a), at which stage, X, Y or Z does most energy pass?

.....[1]

(c) Carbon passes along a food chain in carbon compounds.

(i) Suggest a carbon compound in which carbon might pass from one organism to another.

.....[1]

(ii) Name the compound in which carbon leaves the food chain.

.....[1]

For
Examiner's
Use

- 18 (a) Fig. 18.1 shows two magnets that are repelling each other. One of the magnets has poles marked on it. On Fig. 18.1, label the poles on the unmarked magnet.

For
Examiner's
Use

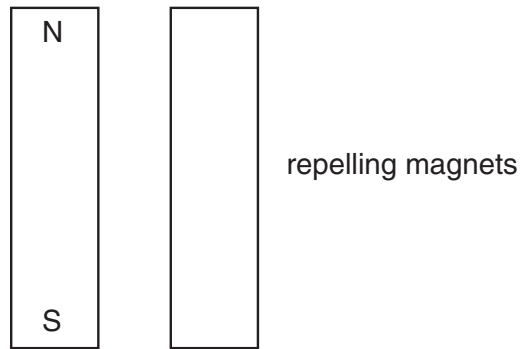

Fig. 18.1

[1]

- (b) Fig. 18.2 shows an electromagnet. The electromagnet has an iron core.

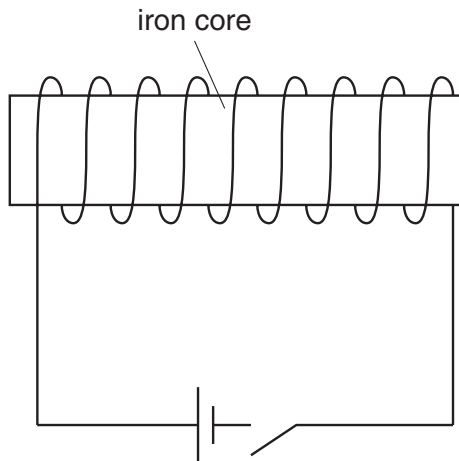

Fig. 18.2

Explain why brass and steel are **not** used for the core.

brass

.....

steel

.....[2]

Permission to reproduce items where third-party owned material protected by copyright is included has been sought and cleared where possible. Every reasonable effort has been made by the publisher (UCLES) to trace copyright holders, but if any items requiring clearance have unwittingly been included, the publisher will be pleased to make amends at the earliest possible opportunity.

University of Cambridge International Examinations is part of the University of Cambridge Local Examinations Syndicate (UCLES), which is itself a department of the University of Cambridge.

