



UNIVERSITY OF CAMBRIDGE INTERNATIONAL EXAMINATIONS
General Certificate of Education Ordinary Level

CHEMISTRY

5070/11

Paper 1 Multiple Choice

May/June 2013

1 hour

Additional Materials: Multiple Choice Answer Sheet
Soft clean eraser
Soft pencil (type B or HB is recommended)



READ THESE INSTRUCTIONS FIRST

Write in soft pencil.

Do not use staples, paper clips, highlighters, glue or correction fluid.

Write your name, Centre number and candidate number on the Answer Sheet in the spaces provided unless this has been done for you.

DO NOT WRITE IN ANY BARCODES.

There are **forty** questions on this paper. Answer **all** questions. For each question there are four possible answers **A, B, C** and **D**.

Choose the **one** you consider correct and record your choice in **soft pencil** on the separate Answer Sheet.

Read the instructions on the Answer Sheet very carefully.

Each correct answer will score one mark. A mark will not be deducted for a wrong answer.

Any rough working should be done in this booklet.

A copy of the Periodic Table is printed on page 16.

Electronic calculators may be used.

This document consists of **13** printed pages and **3** blank pages.



1 In which method of separation are R_f values used?

- A chromatography
- B crystallisation
- C filtration
- D fractional distillation

2 The diagrams show the arrangement of particles in three **solids**: krypton, potassium and sodium chloride.

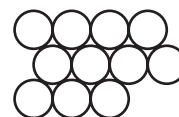
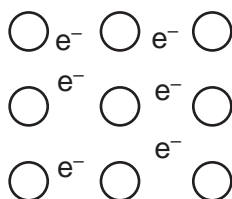
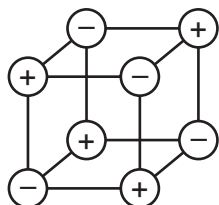

In which order are the solids shown?

- A krypton; potassium; sodium chloride
 - B krypton; sodium chloride; potassium
 - C sodium chloride; krypton; potassium
 - D sodium chloride; potassium; krypton
- 3 In which pair do neither of the gases change the colour of damp blue litmus paper?
- A ammonia and hydrogen
 - B ammonia and hydrogen chloride
 - C carbon dioxide and chlorine
 - D carbon dioxide and sulfur dioxide
- 4 Naturally-occurring bromine has a relative atomic mass of 80 and consists entirely of two isotopes of relative atomic masses 79 and 81.

What can be deduced about naturally-occurring bromine from this information only?

- A Bromine contains the two isotopes in equal proportions.
 - B Bromine has different oxidation states.
 - C Bromine isotopes have different numbers of protons.
 - D Bromine is radioactive.
- 5 Which compound has molecules each of which contains only two covalent bonds?
- A CH_4
 - B H_2O
 - C MgCl_2
 - D Na_2O

- 6 What can be deduced about two gases that have the same relative molecular mass?
- A They have the same boiling point.
 - B They have the same number of atoms in one molecule.
 - C They have the same rate of diffusion at room temperature and pressure.
 - D They have the same solubility in water at room temperature.
- 7 An ionic bond is formed by
- A electron sharing between metals and non-metals.
 - B electron sharing between non-metals.
 - C electron transfer between non-metals.
 - D electron transfer from metals to non-metals.
- 8 Both magnesium oxide, MgO, and aluminium oxide, Al_2O_3 , are solids at room temperature, 25 °C.
- MgO has a melting point of 2852 °C and a boiling point of 3600 °C.
- Al_2O_3 has a melting point of 2072 °C and a boiling point of 2880 °C.
- Over which temperature range will both pure compounds conduct electricity?
- A 25 to 2852 °C
 - B 2072 to 2852 °C
 - C 2852 to 2880 °C
 - D 2880 to 3600 °C
- 9 Which substance conducts an electric current but remains chemically unchanged?
- A aluminium
 - B aqueous sodium chloride
 - C molten lead(II) bromide
 - D pure ethanoic acid
- 10 Which statement most clearly indicates that diamond and graphite are forms of carbon?
- A Both are crystalline solids.
 - B Complete combustion of equal masses of both solids produces equal masses of carbon dioxide as the only product.
 - C Graphite conducts electricity whereas diamond is an insulator.
 - D Under suitable conditions graphite can be partially converted into diamond.

- 11 In an experiment, 1 cm^3 of a gaseous hydrocarbon **X** required 4 cm^3 of oxygen for complete combustion to give 3 cm^3 of carbon dioxide. All gas volumes are measured at r.t.p.

Which formula represents **X**?

- A** C_2H_2 **B** C_2H_4 **C** C_3H_4 **D** C_3H_8

- 12 What is the concentration of a solution containing 1.0 g of sodium hydroxide in 250 cm^3 of solution?

- A** 0.025 mol/dm^3
B 0.10 mol/dm^3
C 0.25 mol/dm^3
D 1.0 mol/dm^3

- 13 The diagrams show an electrolysis experiment using inert electrodes.

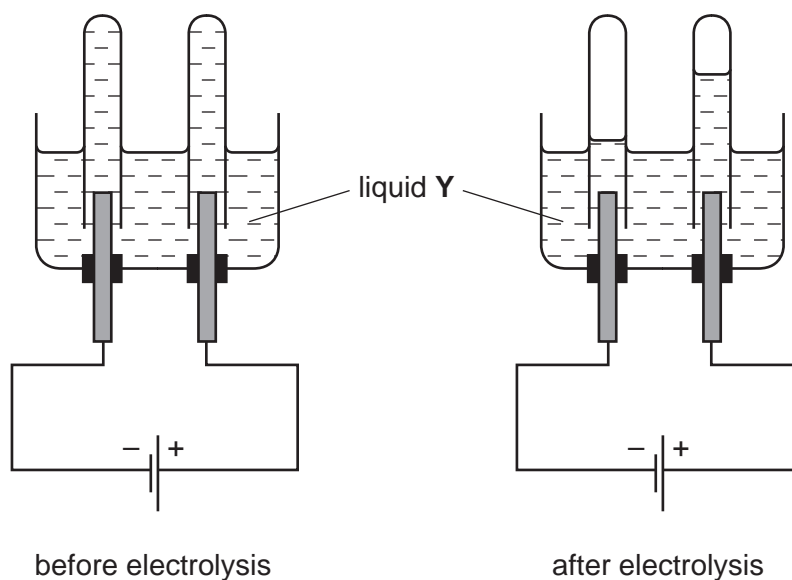

Which could be liquid **Y**?

- A** aqueous copper(II) sulfate
B concentrated aqueous sodium chloride
C dilute sulfuric acid
D ethanol

- 14 Which substance, when added to water, does **not** make a solution that is a good conductor of electricity?
- A barium nitrate
 - B calcium chloride
 - C lead(II) nitrate
 - D zinc carbonate
- 15 A simple cell is shown below.

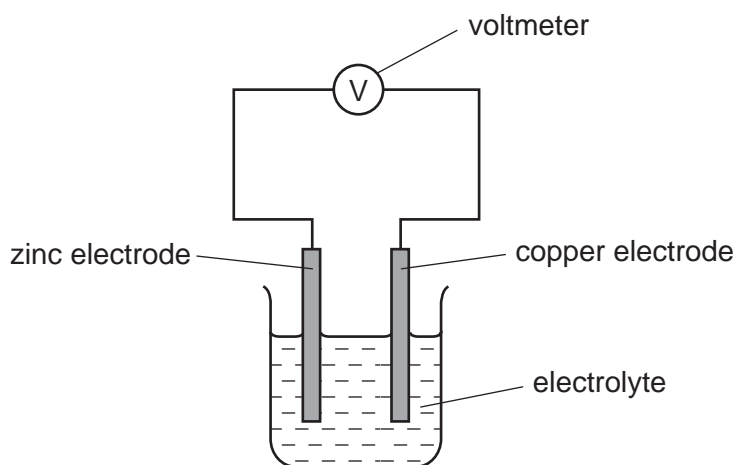

- Which statement about the process occurring when the cell is in operation is correct?
- A Cu^{2+} ions are formed in solution.
 - B Electrons travel through the solution.
 - C The reaction $\text{Zn} \rightarrow \text{Zn}^{2+} + 2\text{e}^-$ occurs.
 - D Zinc increases in mass.
- 16 The usual conditions for the Haber process are 250 atm pressure, 450 °C and an iron catalyst.
- Which change in conditions would give the reactants more energy?
- A addition of more catalyst
 - B a decrease in pressure
 - C an increase in concentration of the reactants
 - D an increase in temperature

17 Chlorine can be manufactured by the following reaction.

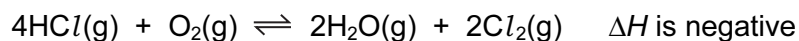

A mixture in dynamic equilibrium is formed.

Which change to the mixture will increase the amount of chlorine at equilibrium?

- A adding a catalyst
- B adding more $\text{HCl}(\text{g})$
- C decreasing the pressure
- D increasing the temperature

18 Equations for reactions of iron and iron compounds are shown.

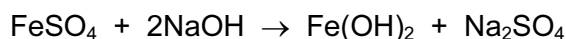
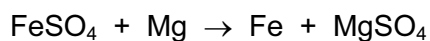
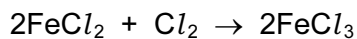
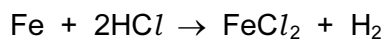

How many of these are redox reactions?

- A 1 B 2 C 3 D 4

19 Which is a use of sulfuric acid?

- A as a bleach
- B in the manufacture of ammonia
- C in the manufacture of fertilisers
- D in the manufacture of sulfur trioxide

20 The table shows the solubility of some compounds of metal Q in cold water.

| salt | solubility in cold water |
|-----------|--------------------------|
| carbonate | insoluble |
| chloride | soluble |
| sulfate | insoluble |

What is metal Q?

- A barium
- B lead
- C magnesium
- D sodium

21 A metal *M* forms a chloride which dissolves in cold water and has an oxide which dissolves in both strong acids and strong alkalis.

What is *M*?

- A iron
- B lead
- C sodium
- D zinc

22 Which element has a variable oxidation state, can act as a catalyst and forms coloured compounds?

- A carbon
- B iron
- C lead
- D nitrogen

23 An atom of which element has the same electronic configuration as the strontium ion?

- A calcium
- B krypton
- C rubidium
- D selenium

24 The boiling points of gaseous elements increase as the size of their atoms increases.

Which of these noble gases has the highest boiling point?

- A argon
- B helium
- C krypton
- D neon

25 The sentence describes two metals and their oxides.

Metal X could be copper because its oxide is1..... and metal Y could be2..... because its oxide is amphoteric.

Which words correctly complete gaps 1 and 2?

| | 1 | 2 |
|---|--------|-----------|
| A | acidic | aluminium |
| B | basic | aluminium |
| C | acidic | magnesium |
| D | basic | magnesium |

26 Which gas could be used to convert copper(II) oxide to copper?

- A carbon dioxide
- B hydrogen
- C nitrogen
- D oxygen

27 Aluminium and copper are often used to make coins but iron is not.

Which statement explains this?

- A Iron is above both aluminium and copper in the reactivity series.
- B Iron is more expensive to manufacture than aluminium or copper.
- C Iron is rarer than both aluminium and copper.
- D Iron reacts with water.

28 In the electrolysis of molten aluminium oxide for the extraction of aluminium, the following three reactions take place.

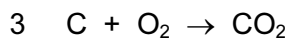
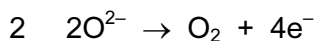
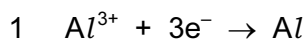

Which reactions take place at the positive electrode?

- A** 1 only **B** 2 only **C** 1 and 3 only **D** 2 and 3 only

29 Which two substances are removed from the bottom of the blast furnace?

1 coke

2 iron

3 limestone

4 slag

- A** 1 and 3 **B** 1 and 4 **C** 2 and 3 **D** 2 and 4

30 An alloy of copper and zinc is added to an excess of dilute hydrochloric acid. The resulting mixture is then filtered.

Which observations are correct?

| | filtrate | residue |
|----------|---------------------|-----------|
| A | colourless solution | none |
| B | colourless solution | red-brown |
| C | blue solution | grey |
| D | blue solution | none |

31 Which aqueous reagent liberates ammonia from ammonium nitrate on warming?

A calcium nitrate

B potassium hydroxide

C sodium chloride

D sulfuric acid

32 An aqueous solution of a compound **X** reacts with

- aqueous zinc chloride to form a white precipitate which dissolves when **X** is in excess,
- aluminium sulfate solution to form a white precipitate which is insoluble when **X** is in excess.

What is the identity of **X**?

- A** ammonia
- B** barium chloride
- C** silver nitrate
- D** sodium hydroxide
- 33 CFC compounds were commonly used as aerosol propellants. The structure of one CFC compound is shown.

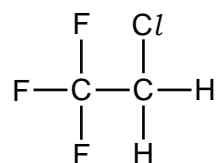

Which element in this compound causes a depletion of ozone in the atmosphere?

- A** carbon
- B** chlorine
- C** fluorine
- D** hydrogen
- 34 Which gas is most likely to react with limestone?
- A** ammonia
- B** carbon monoxide
- C** methane
- D** sulfur dioxide

35 The diagram shows the structure of an ester.

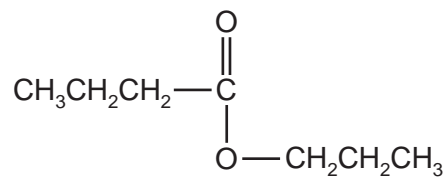

What are the starting materials for making this compound?

- A butanol and butanoic acid
- B butanol and propanoic acid
- C propanol and butanoic acid
- D propanol and propanoic acid

36 Which information is correct regarding the formation of ethanol by the process of fermentation?

| | substances fermented | gas evolved during fermentation |
|---|----------------------|---------------------------------|
| A | carbohydrates | carbon dioxide |
| B | carbohydrates | carbon monoxide |
| C | hydrocarbons | carbon dioxide |
| D | hydrocarbons | carbon monoxide |

37 Nylon, poly(ethene) and *Terylene* are macromolecules.

In which of these macromolecules is the C=O group present in the linkage?

- A nylon and *Terylene* only
- B nylon only
- C poly(ethene) and *Terylene* only
- D *Terylene* only

38 Which partial structure is correct for the product of polymerisation of butene, $\text{CH}_2=\text{CHCH}_2\text{CH}_3$?

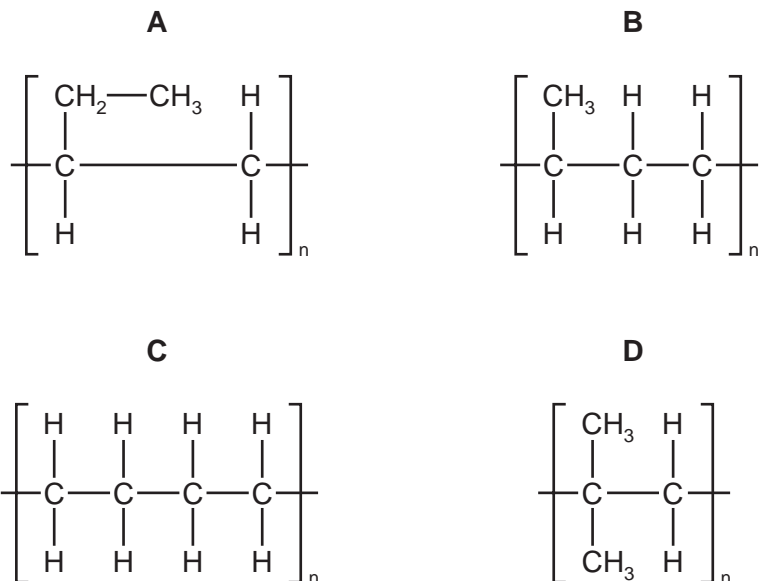

39 Glucose is a simple sugar. Glycine is an amino acid.

In the diagram, which two arrows correctly show the hydrolysis products of a carbohydrate and of a protein?

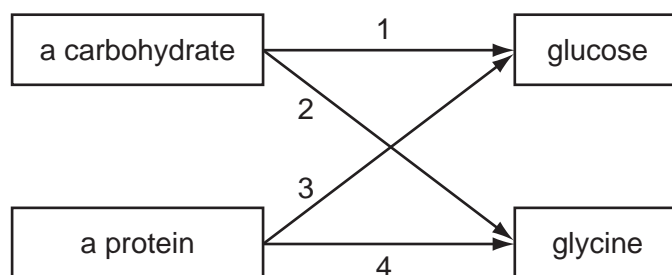

A 1 and 3 **B** 1 and 4 **C** 2 and 3 **D** 2 and 4

40 When crude oil is distilled several products are obtained.

What is the correct order of their boiling points?

| | highest boiling point → lowest boiling point | | | |
|----------|---|---------------------|---------------------|-------------------|
| A | diesel | paraffin (kerosene) | petrol (gasoline) | lubricating oil |
| B | lubricating oil | diesel | paraffin (kerosene) | petrol (gasoline) |
| C | paraffin (kerosene) | petrol (gasoline) | lubricating oil | diesel |
| D | petrol (gasoline) | paraffin (kerosene) | diesel | lubricating oil |

DATA SHEET
The Periodic Table of the Elements

| | | Group | | | | | | | | | | | | | | | | | | |
|-----|----------------------------|---|------------------------------|-------------------------------------|------------------------------------|------------------------------------|-------------------------------------|-------------------------------------|-------------------------------------|-----------------------------------|-------------------------------------|----------------------------------|-----------------------------------|------------------------------------|------------------------------------|------------------------------------|-------------------------------------|------------------------------------|----------------------------------|--------------------------------|
| | | I | II | III | IV | V | VI | VII | VIII | IX | X | | | | | | | | | |
| | | 1 H Hydrogen 1 | | | | | | | | | | | | | | | | | | |
| 7 | 9 | Li Lithium 3 | Be Beryllium 4 | | | | | | | | | He Helium 2 | | | | | | | | |
| 23 | 24 | Na Sodium 11 | Mg Magnesium 12 | | | | | | | | | Ne Neon 10 | | | | | | | | |
| 39 | 40 | K Potassium 19 | Ca Calcium 20 | 45 Sc Scandium 21 | 48 Ti Titanium 22 | 51 V Vanadium 23 | 52 Cr Chromium 24 | 55 Mn Manganese 25 | 56 Fe Iron 26 | 59 Co Cobalt 27 | 59 Ni Nickel 28 | 64 Cu Copper 29 | 65 Zn Zinc 30 | 70 Ga Gallium 31 | 73 Ge Germanium 32 | 75 As Arsenic 33 | 79 Se Selenium 34 | 80 Br Bromine 35 | 84 Kr Krypton 36 | |
| 85 | 88 | Rb Rubidium 37 | Sr Strontium 38 | 89 Y Yttrium 39 | 91 Zr Zirconium 40 | 93 Nb Niobium 41 | 96 Mo Molybdenum 42 | 101 Ru Ruthenium 44 | 101 Ru Ruthenium 44 | 103 Rh Rhodium 45 | 106 Pd Palladium 46 | 108 Ag Silver 47 | 112 Cd Cadmium 48 | 115 In Indium 49 | 119 Sn Tin 50 | 122 Sb Antimony 51 | 128 Te Tellurium 52 | 127 I Iodine 53 | 131 Xe Xenon 54 | |
| 133 | 137 | Cs Caesium 55 | Ba Barium 56 | 139 La Lanthanum 57 | 178 Hf Hafnium 72 | 181 Ta Tantalum 73 | 184 W Tungsten 74 | 190 Os Osmium 76 | 190 Os Osmium 76 | 192 Ir Iridium 77 | 195 Pt Platinum 78 | 197 Au Gold 79 | 201 Hg Mercury 80 | 204 Tl Thallium 81 | 207 Pb Lead 82 | 209 Bi Bismuth 83 | 210 Po Polonium 84 | 210 At Astatine 85 | 210 Rn Radon 86 | |
| 87 | 226 | Fr Francium 87 | Ra Radium 88 | 227 Ac Actinium 89 | | | | | | | | | | | | | | | | |
| | | *58-71 Lanthanoid series †90-103 Actinoid series | | | | | | | | | | | | | | | | | | |
| Key | a | X | b | | | | | | | | | | | | | | | | | |
| | a = relative atomic mass | X = atomic symbol | b = proton (atomic) number | | | | | | | | | | | | | | | | | |
| | 140 | 141 | 144 | 150 | 152 | 157 | 159 | 162 | 165 | 167 | 169 | 173 | 175 | 175 | 175 | 175 | 175 | 175 | 175 | 175 |
| | Ce Cerium 58 | Pr Praseodymium 59 | Nd Neodymium 60 | Sm Samarium 62 | Eu Europium 63 | Gd Gadolinium 64 | Tb Terbium 65 | Dy Dysprosium 66 | Ho Holmium 67 | Er Erbium 68 | Tm Thulium 69 | Yb Ytterbium 70 | Lu Lutetium 71 | Lu Lutetium 71 | Lu Lutetium 71 | Lu Lutetium 71 | Lu Lutetium 71 | Lu Lutetium 71 | Lu Lutetium 71 | Lu Lutetium 71 |
| | 232 | 232 | 238 | 238 | 238 | 238 | 238 | 238 | 238 | 238 | 238 | 238 | 238 | 238 | 238 | 238 | 238 | 238 | 238 | 238 |
| | Th Thorium 90 | Pa Protactinium 91 | U Uranium 92 | Np Neptunium 93 | Pu Plutonium 94 | Am Americium 95 | Cm Curium 96 | Bk Berkelium 97 | Cf Californium 98 | Es Einsteinium 99 | Fm Fermium 100 | Md Mendelevium 101 | No Nobelium 102 | Lr Lawrencium 103 | Lr Lawrencium 103 | Lr Lawrencium 103 | Lr Lawrencium 103 | Lr Lawrencium 103 | Lr Lawrencium 103 | Lr Lawrencium 103 |

The volume of one mole of any gas is 24 dm³ at room temperature and pressure (r.t.p.).

Permission to reproduce items where third-party owned material protected by copyright is included has been sought and cleared where possible. Every reasonable effort has been made by the publisher (UCLES) to trace copyright holders, but if any items requiring clearance have unwittingly been included, the publisher will be pleased to make amends at the earliest possible opportunity.

University of Cambridge International Examinations is part of the Cambridge Assessment Group. Cambridge Assessment is the brand name of University of Cambridge Local Examinations Syndicate (UCLES), which is itself a department of the University of Cambridge.