

SECTION 1: Answer **one** question from this section.

Question 1

The sketch on the right shows details of a collection box used by a charity for the homeless. The box is made from card.

(a) In the space below draw the following full size orthographic views of the charity box:

- (i) a plan in the direction of **P**; [5]
- (ii) a front view in the direction of **FE**; [6]
- (iii) an end view in the direction of **EE**. [5]

Estimate any dimensions not given.

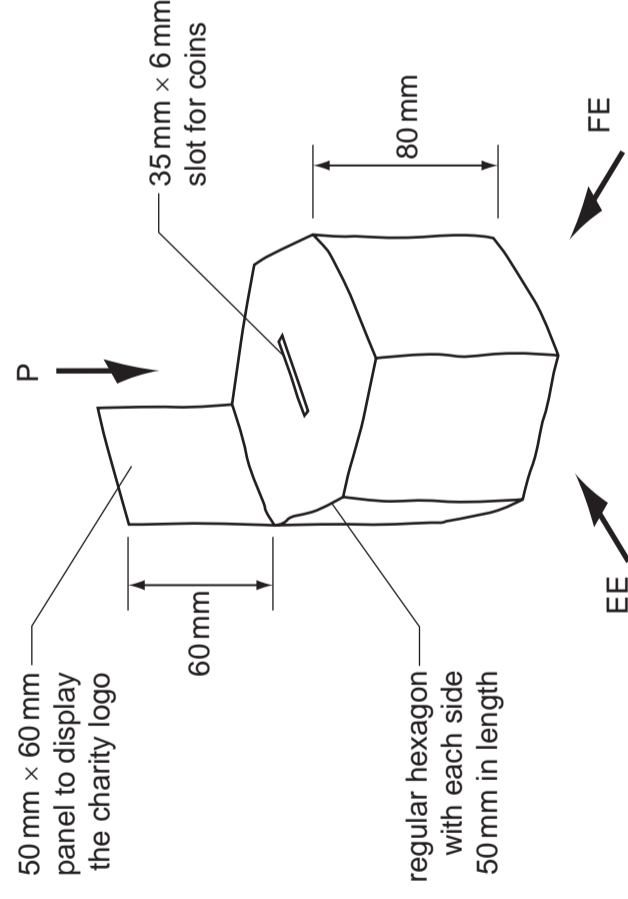

(b) In the space below complete the sketch of the development (net) of the piece of card required to make the collection box. Clearly show all fold lines and glue tabs. [7]

SKETCH
SCALE 1:2

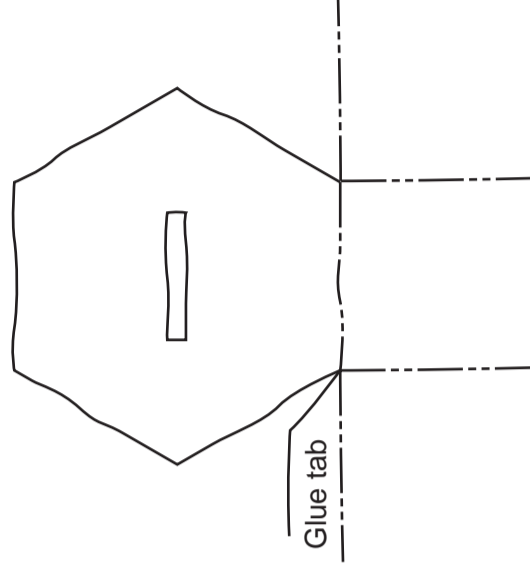

(c) The charity for the homeless requires a logo for the collection box. Specification points for the logo are that it will include:

- an image of a house;
- the word HAVEN.

(i) In the space below use sketches and notes to develop an idea for the logo for the collection box. [4]

final logo

idea for the logo

[Turn over



UNIVERSITY OF CAMBRIDGE INTERNATIONAL EXAMINATIONS
General Certificate of Education Ordinary Level

7048/01

October/November 2011

2 hours 30 minutes

plus 15 minutes reading time

IB11 11_7048_01/5RP

CDT: DESIGN AND COMMUNICATION

Paper 1

No Additional Materials are required

© UCLES 2011

SHEET 1 OF 2 (SECTION 1)

Write your surname, other names, Centre number and candidate number in the spaces provided.

Answer **one** question only from Section 1 (Questions 1 and 2).

Answer **two** questions only from Section 2 (Questions 3 to 6).

Answer the questions in the spaces provided.

All construction and projection lines must be clearly shown.

All dimensions are in millimetres unless otherwise stated.

The number of marks is given in brackets [] at the end of each question or part question.

DO NOT WRITE IN ANY BARCODES.

Candidate Surname

Other Names

Centre Number

Candidate Number

Examiner's use only

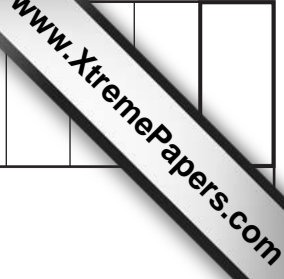

Question 2

Orthographic views of a display stand and a foam board information panel are shown on the right. The stand is made from 30mm square section tubular steel.

(a) Complete the isometric drawing of the display stand to a scale of 1:5 from the given start point **A**.

Estimate any dimensions not given. [13]

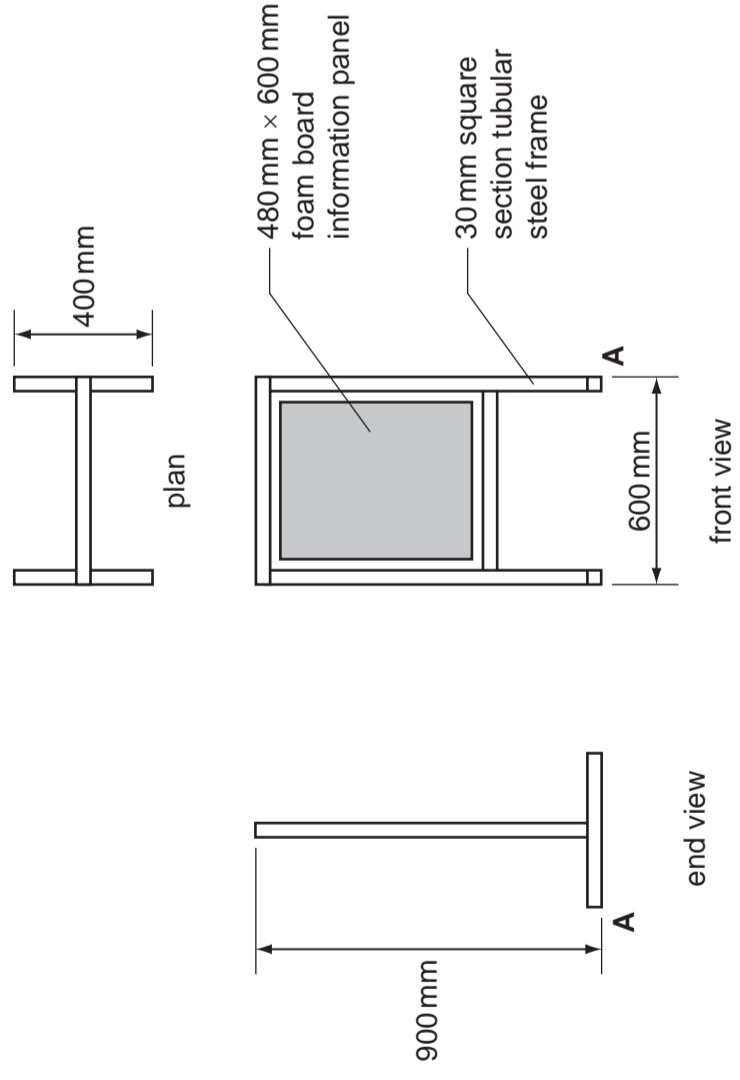

(b) Orthographic views of the top corner of the display stand are shown on the right.

(i) In the space below sketch an exploded three-dimensional view of the corner of the display stand to show how it is held together. [10]

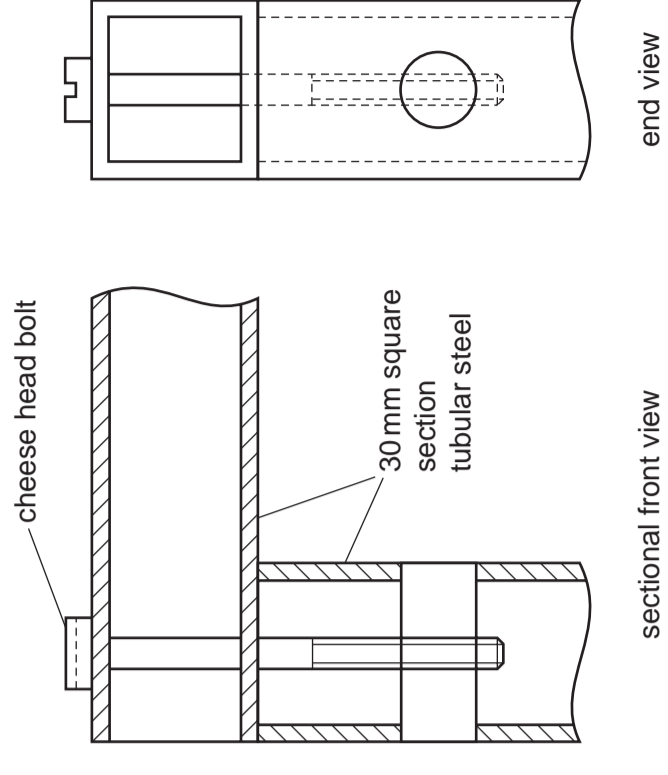

(c) The foam board information panel is held in place in the steel frame by four fasteners. Specification points for the fasteners are that they:

- fix to the frame of the display stand;
- hold the foam board in position;
- allow the foam board to be removed easily.

(i) In the space below use sketches and notes to develop an idea for the fastener. [4]

(ii) In the space below produce a three-dimensional sketch of your final design for the fastener. The sketch should be rendered to show an appropriate material. [3]

→ A

idea for the fastener

final design for the fastener

SECTION 2: Answer **two** questions from this section.

Question 3

The drawings below show three designs for temporary accommodation that is to be used when a natural disaster occurs.

(a) Complete the drawings by adding:

(i) a planometric drawing of design 1; [5]

(ii) orthographic front and end views of design 2; [5]

(iii) an estimated two point perspective drawing of design 3. [5]

<p>Design 1</p> <p style="text-align: center;">front view plan</p> <p style="text-align: center;">Planometric</p>	<p>Design 2</p> <p style="text-align: center;">end view front view</p> <p style="text-align: center;">Orthographic</p> <p style="text-align: center;">square base</p>	<p>Design 3</p> <p style="text-align: center;">front view plan</p> <p style="text-align: center;">Estimated two point perspective</p>
---	---	---

(b) A leaflet to advertise the temporary accommodation is shown on the right. The leaflet is to have three symbols. The symbol for 'compact' has been completed.

(i) Use the space below to develop an idea for a design for the following symbols:

- waterproof;
- easy assembly.

[4]

(ii) Complete the final design for the leaflet by:

- adding tone to the drawing of the accommodation;
- adding your 'waterproof' symbol in an appropriate style;
- adding your 'easy assembly' symbol in an appropriate style. [6]

Tempacom
When disaster strikes we are at hand

compact waterproof easy assembly

Question 4

AQUA is a brand of clean drinking water that is distributed in times of natural disasters. Orthographic views and a three-dimensional drawing of an AQUA carton are shown below.

(a) Complete the three-dimensional drawing by adding:

(i) the name AQUA; [3]

(ii) the wave design. [3]

orthographic views of carton

three-dimensional drawing of carton

(c) The development (net) of a card tray for a pack of AQUA cartons is shown below.

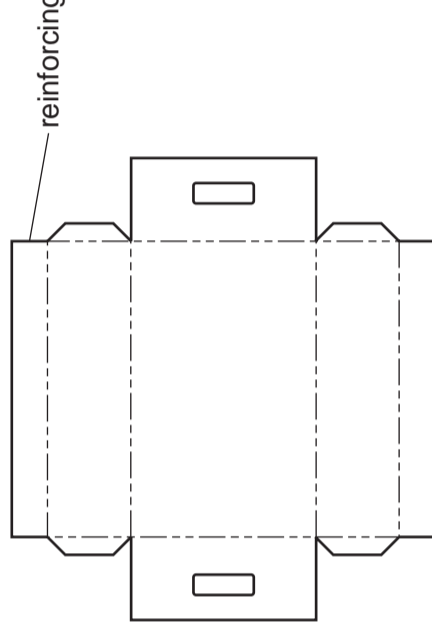

(i) In the space below sketch an isometric view of the fully assembled card tray. Do **not** include an AQUA pack. [8]

Cartons of AQUA are transported in a pack that is five cartons wide and six cartons long.

(b) Accurately complete the orthographic drawings of the AQUA pack shown below. Do **not** add any graphics to the AQUA cartons. [5]

plan

front view

(ii) Complete the assembly instructions for the card tray by adding sketches in the spaces provided. [6]

	Bend along the fold lines		
	Apply glue to the tabs		
		Hold for 5 minutes	
			Place pack in tray

[Turn over]

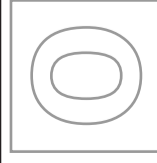

UNIVERSITY OF CAMBRIDGE INTERNATIONAL EXAMINATIONS
General Certificate of Education Ordinary Level

7048/01

October/November 2011

2 hours 30 minutes

plus 15 minutes reading time

IB11 11_7048_01/5RP

CDT: DESIGN AND COMMUNICATION

Paper 1

No Additional Materials are required

© UCLES 2011

SHEET 2 OF 2 (SECTION 2)
Write your surname, other names, Centre number and candidate number in the spaces provided.

Answer **one** question only from Section 1 (Questions 1 and 2).

Answer **two** questions only from Section 2 (Questions 3 to 6).

Answer the questions in the spaces provided.

All construction and projection lines must be clearly shown.

All dimensions are in millimetres unless otherwise stated.

The number of marks is given in brackets [] at the end of each question or part question.

Candidate Surname
Other Names
Centre Number
Candidate Number

Question 5

Supplies are flown to areas of natural disaster and dropped by parachute.

- (a) Complete the 1 mm to 10 km scale drawing of a flight path to a drop zone from the given start point. The plane flies 500 km North (N), then 800 km North East (NE) and finally 400 km South (S). [6]

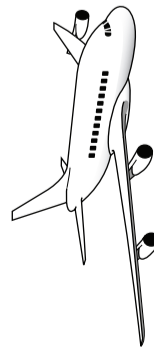

start point
↑

- (b) The drop zone is identified by the word 'DROP' and a shape drawn on the ground. Construct a scale 1:1000 drawing of the drop zone on the given centre lines shown below. [8]

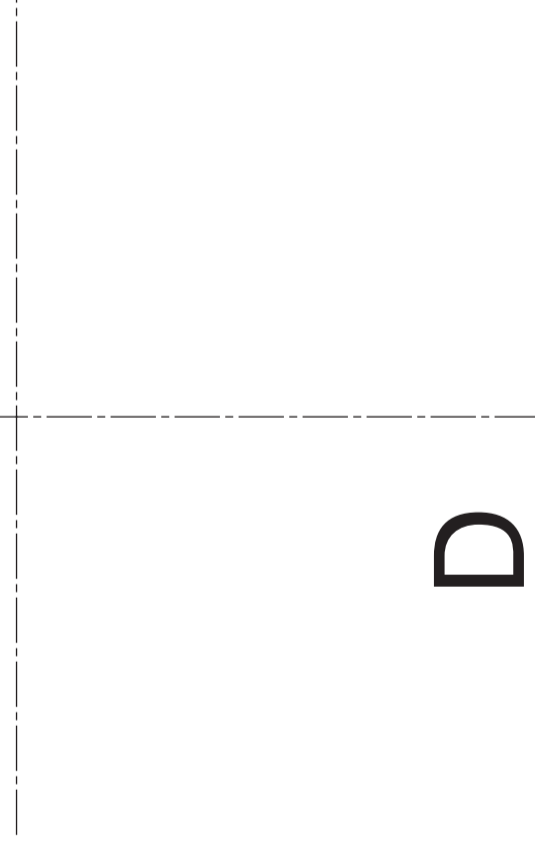
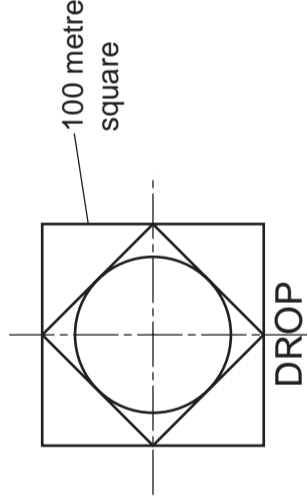

- (c) After cylindrical barrels of fuel are delivered, they are rolled along because they are too heavy to lift.

On the start position below construct a 1:10 scale drawing to show the path of the two openings (T1 and T2) on the end of the barrel as it is rolled for half a turn. [11]

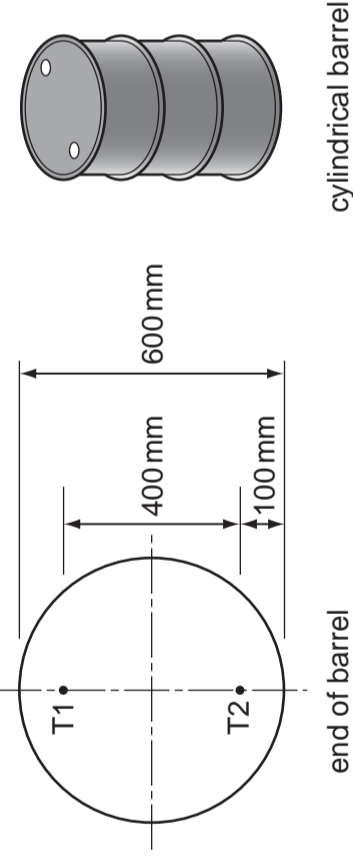
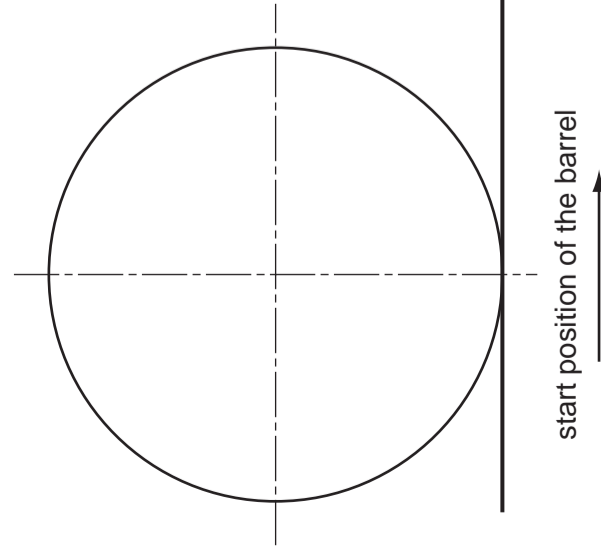

end of barrel

cylindrical barrel

Question 6

A disaster relief charity requires a series of illustrations for a brochure.

- (a) In the space below draw a **pie chart** to show the main types of disaster. Use colour and labels to enhance your illustration. [5]

	Millions of people
Flood	120
Drought	60
War	45
Famine	135

pie chart

- (b) In the space below draw a **line graph** to show the rise in the cost of temporary shelter from 2007 to 2010. Use labels to enhance your illustration. [5]

	\$ per day
2007	20
2008	30
2009	40
2010	60

line graph

- (c) In the space below draw and label a **three-dimensional bar chart** to show the fall in response times to a disaster over the period 2007 to 2010. [5]

	Hours
2007	36
2008	28
2009	20
2010	12

bar chart

- (d) The **activity chart** on the right shows the stages that the charity goes through when responding to a disaster. Draw the activity chart full size on the centre lines below. Estimate any dimensions not given. [10]

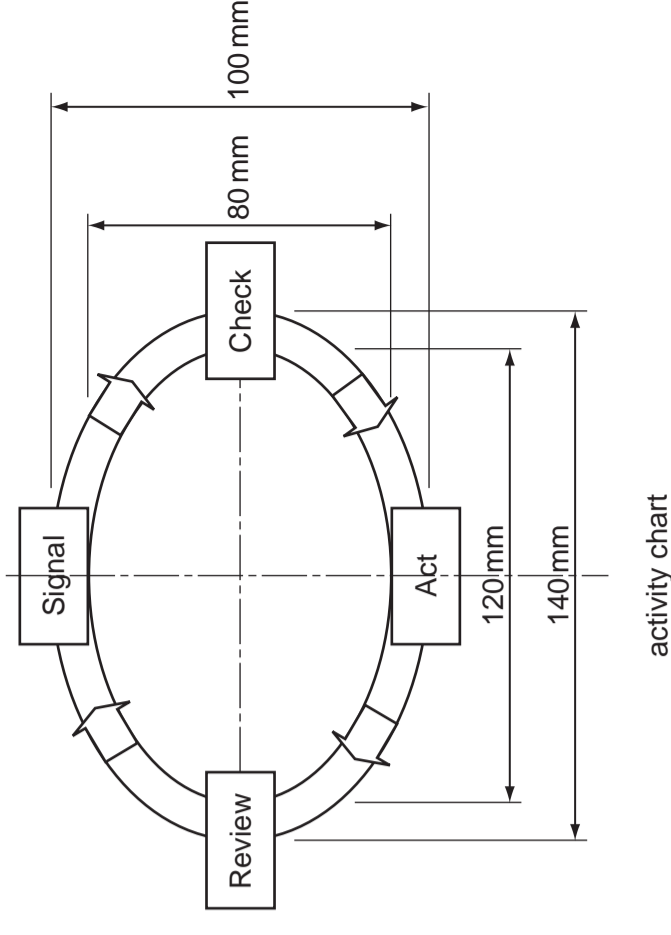

activity chart

