

UNIVERSITY OF CAMBRIDGE INTERNATIONAL EXAMINATIONS  
General Certificate of Education Ordinary Level

**BIOLOGY**

Paper 3 Practical Test



**5090/03**

October/November 2006

**1 hour 15 minutes**

Candidates answer on the Question Paper.

Additional Materials: As listed in the Instructions to Supervisors.

Candidate  
Name

--

Centre  
Number

--	--	--	--	--

Candidate  
Number

--	--	--	--

**READ THESE INSTRUCTIONS FIRST**

Write your Centre number, candidate number and name in the spaces provided at the top of this page.

Write in dark blue or black pen.

You may use a pencil for any diagrams, graphs or rough working.

Do not use staples, paper clips, highlighters, glue or correction fluid.

Answer **both** questions.

At the end of the examination, fasten all your work securely together.

The number of marks is given in brackets [ ] at the end of each question or part question.

For Examiner's Use	
1	
2	
<b>Total</b>	

This document consists of 7 printed pages and 1 blank page.



- 1 • Place the slice of banana fruit, **W1**, on its side, on the white tile and cut it as shown in Fig. 1.1 to produce three complete slices.
- Put two of the slices to one side for use later in **(b)(ii)** and **(d)**.
- Place the other slice flat on the tile and cover its upper surface with iodine solution.
- Observe how its appearance changes over the next two to three minutes.

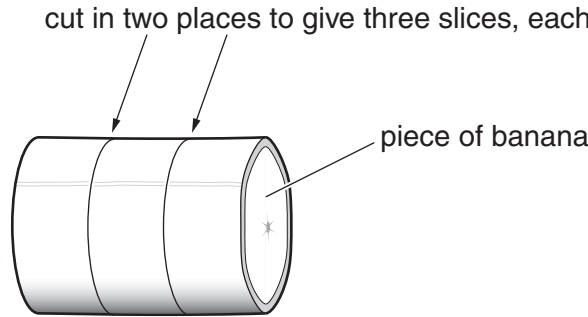

**Fig. 1.1**

**(a)** Describe briefly, but do not draw, these changes.

.....  
.....  
.....  
.....[3]

**(b) (i)** Describe how you would carry out the test for reducing sugar on a piece of banana.

.....  
.....  
.....  
.....  
.....[4]

- (ii) • Cut, from one of the unused slices of banana, approximately 1 cm<sup>3</sup> of the inner succulent part of the fruit.
- Test this for the presence of reducing sugar.
- Record what you observe and state your conclusion.

observation

.....  
.....

conclusion .....[3]

- (c) The carbohydrate in a banana changes as it grows and ripens.

Make an outline plan of an investigation that you could perform to show how the carbohydrate changes as the banana grows and ripens.

.....  
.....  
.....  
.....  
.....  
.....  
.....  
.....[6]

(d) **W2** is a slice of another fruit, the cucumber.

For  
Examiner's  
Use

Examine the remaining, unused slice of banana and **W2**.

If a ripe cucumber was left on the surface of the soil young plants may grow from it.

If a ripe banana was left on the surface of the soil young plants do not grow from it.

(i) Suggest why young plants are produced from a cucumber fruit but not from the banana.

.....  
.....  
.....[2]

(ii) Suggest how, if banana plants will not grow from fruits, new banana plants may be produced.

.....  
.....  
.....[2]

[Total : 20]

- 2
- Look down the inside of the tube of the flower, **W3**.
  - Observe the reproductive structures.
  - Slit open the tube to expose these reproductive structures clearly – do **not** remove them.
  - There is no need to open the calyx.
- (a) (i) Make a large, labelled drawing to show the structure of the flower.

*For  
Examiner's  
Use*

[7]

- (ii) Use the hand lens to examine one of the structures in which pollen is produced and make a large, labelled drawing of this structure, including a short piece of its 'stalk'.

*For  
Examiner's  
Use*

[4]

- (iii) • Measure and record the length of your drawing. ....
- Indicate on your drawing where the measurement was taken.
  - Measure and record the length of the same part of the actual specimen.  
.....
  - Calculate the magnification of your drawing. Show your working clearly.

Magnification = .....

[3]

- (b) (i) Examine specimen **W4**.

Complete **Table 2.1** to show differences between **W3** and **W4** that can be seen.  
The first row of boxes has been done for you.

For  
Examiner's  
Use

**Table 2.1**

feature	<b>W3</b>	<b>W4</b>
size of flower	large	small

[4]

- (ii) Suggest how pollination occurs in **W3** and **W4** and state **one** feature of each that supports your answer.

**W3** .....

.....

**W4** .....

.....[2]

[Total : 20]

**BLANK PAGE**

---

Permission to reproduce items where third-party owned material protected by copyright is included has been sought and cleared where possible. Every reasonable effort has been made by the publisher (UCLES) to trace copyright holders, but if any items requiring clearance have unwittingly been included, the publisher will be pleased to make amends at the earliest possible opportunity.

University of Cambridge International Examinations is part of the University of Cambridge Local Examinations Syndicate (UCLES), which is itself a department of the University of Cambridge.