

Candidate Name _____

Centre Number	Candidate Number

CAMBRIDGE INTERNATIONAL EXAMINATIONS
General Certificate of Education Ordinary Level
AGRICULTURE
PAPER 1

5038/1

MAY/JUNE SESSION 2002

2 hours

Additional materials:
Answer paper

TIME 2 hours

INSTRUCTIONS TO CANDIDATES

Write your name, Centre number and candidate number in the spaces at the top of this page and on all separate answer paper used.

Section A

Answer **all** questions.

Write your answers in the spaces provided on the question paper.

Section B

Answer any **three** questions.

Write your answers on the separate answer paper provided.

At the end of the examination,

1. fasten all separate answer paper securely to the question paper;
2. enter the numbers of the Section B questions you have answered in the left hand column of the grid below.

INFORMATION FOR CANDIDATES

The intended number of marks is given in brackets [] at the end of each question or part question.

You are advised to spend no longer than 1 hour on Section A.

FOR EXAMINER'S USE	
Section A	
Section B	
TOTAL	

This question paper consists of 11 printed pages and 1 blank page.



Section A

Answer **all** the questions.

Write your answers in the spaces provided.

- 1 (a) Fig. 1.1 shows a section through a maize seed.

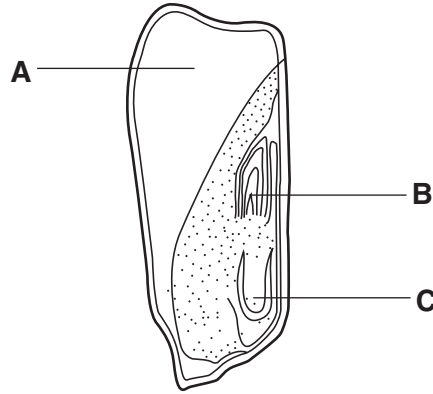

Fig. 1.1

- (i) Name structures **A**, **B** and **C**.

A

B

C

[3]

- (ii) What is the function of **C**?

.....[1]

- (b) Seeds should be sown at the recommended depth for the type of seed.

State why germination is likely to be poor if sowing is too shallow or too deep.

too shallow

.....
.....

too deep

.....
.....[2]

- (c) Suggest **one** advantage of sowing seeds in rows rather than broadcasting them.

.....
.....[1]

[Total : 7]

2 (a) Fig. 2.1 shows the digestive system in a chicken.

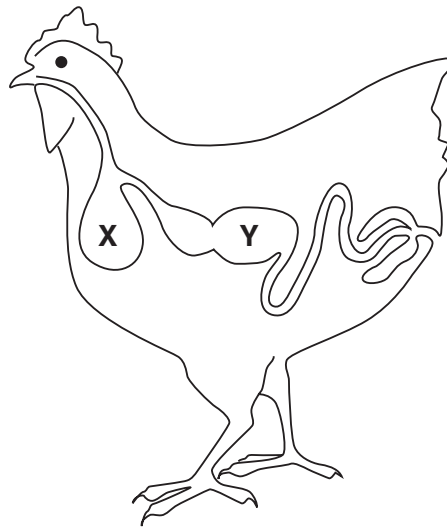

Fig. 2.1

(i) Name X and Y.

X

Y

[1]

(ii) State the functions of X and Y.

X

Y[2]

(b) The partially completed Table 2.1 shows the main food groups needed by animals in their diets, a possible source and their use by the animal.

(i) For a **named** type of livestock, complete the table.

type of livestock

Table 2.1

food group	source	use
carbohydrate		energy
		growth and repair
fat	oil seed cake	

[4]

(ii) Name two other components of a balanced diet **not** shown in Table 2.1.

1.

2.

[2]

[Total : 9]

3 (a) (i) State what is meant by

monoculture;

.....

crop rotation.

.....[2]

(ii) State two reasons for crop rotation.

1.

.....

2.

.....[2]

(b) *Acacia albida* is a leguminous tree, which is sometimes planted to improve the fertility of crop and pasture land. Its pods and seeds can be used as animal fodder.

Suggest

(i) how it improves soil fertility;

.....

.....[2]

(ii) why it is a valuable animal fodder.

.....

.....[1]

[Total : 7]

4 (a) Fig. 4.1 shows a house for small animals.

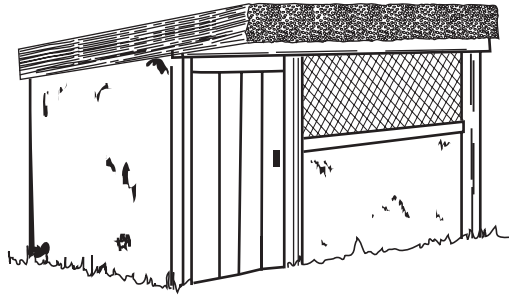

Fig. 4.1

(i) State one advantage and one disadvantage of using wire mesh for the window.

advantage

disadvantage[2]

(ii) State one advantage and one disadvantage of using thatch for the roof.

advantage

disadvantage[2]

(b) An animal house is used to raise chickens for slaughter. When the birds have been killed and sold, the farmer wants to re-stock with new birds.

Describe the preparation of the house before re-stocking.

.....

.....

.....

.....[3]

[Total : 7]

5 Table 5.1 shows the range of pH at which various crops can be grown.

Table 5.1

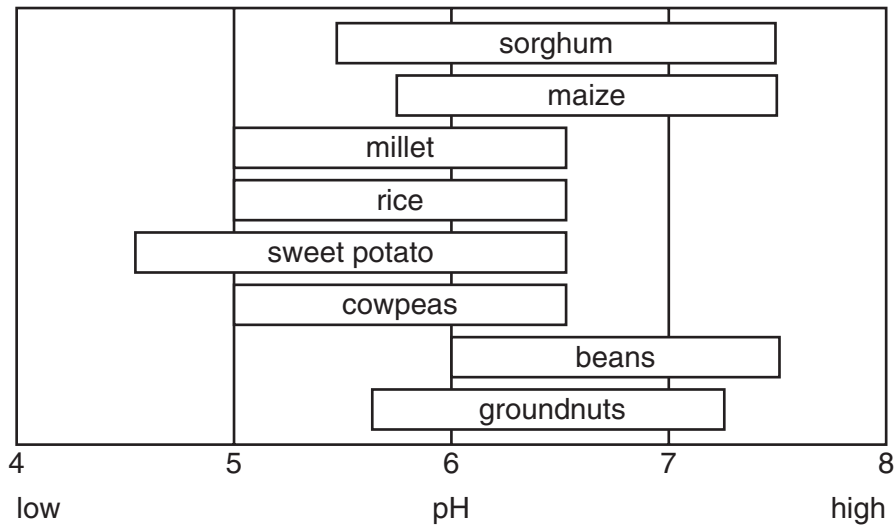

(a) (i) Which crops must have acidic conditions to grow?

.....[2]

(ii) Fig. 5.1 shows the pH of a soil recorded on a pH meter.

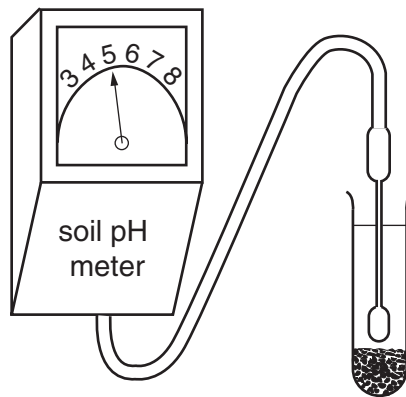

Fig. 5.1

How could a farmer treat this soil in order to grow beans?

.....[1]

(b) Why do crop plants **not** grow well in soils with a pH above 7.5?

.....[1]

(c) Describe a test (other than by using a meter) to find the pH of a sample of soil.

.....

.....

.....

.....

.....[4]

[Total : 8]

6 Two forms of maize, yellow-seeded and white-seeded, are controlled by two alleles, **A** (dominant, yellow) and **a** (recessive, white).

(a) State the genotypes for

(i) yellow-seeded plants,

(ii) white-seeded plants.[2]

(b) A heterozygous, yellow-seeded plant is crossed with a white-seeded plant.

(i) Draw a diagram to show this cross.

[2]

(ii) What proportion of the resulting plants will be homozygous?[1]

[Total : 5]

7 Fig. 7.1 shows one stroke in the four-stroke cycle of a petrol engine.

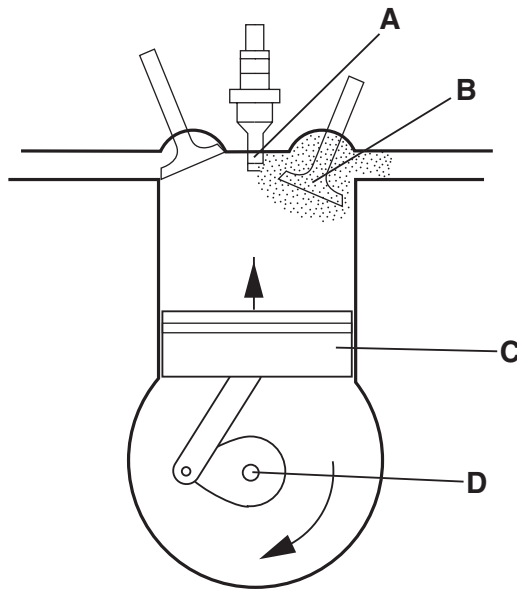

Fig. 7.1

(a) Which stroke, in the four-stroke cycle, is shown?

.....

[1]

(b) Name B, C and D.

B

C

D

[3]

(c) What is the function of A?

.....

.....[2]

(d) Why is A not found in a diesel engine?

.....

.....[1]

[Total : 7]

8 The pie charts in Fig. 8.1 show the yield of four cereal crops and the losses to insects, weeds and disease.

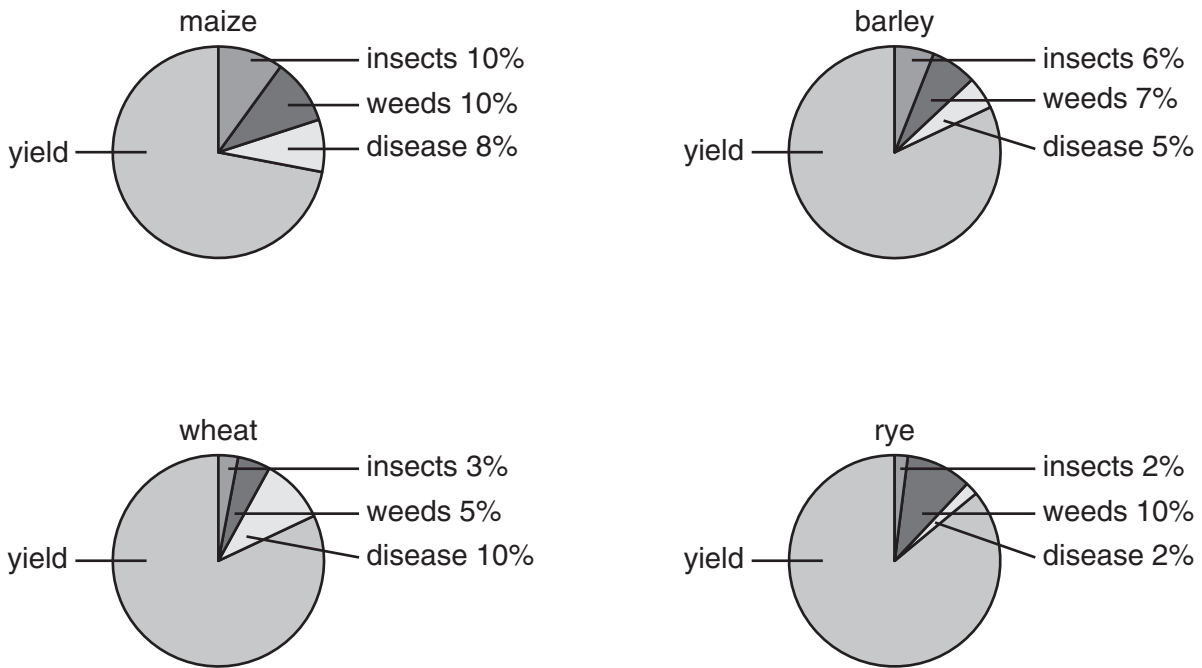

Fig. 8.1

- (a) (i) Which crop shows the greatest loss of yield?[1]
- (ii) Which factor (insects, weeds or disease) has caused the greatest loss over all four crops?
.....[1]

(b) List three ways in which the factor named in (a)(ii) causes loss of yield.

1.
2.
3.[3]

[Total : 5]

Section B

Answer any **three** questions.

Write your answers on the separate answer paper provided.

9 (a) Outline the reasons why land may be used for forestry and game reserves, rather than for growing crops or keeping livestock. [7]

(b) Discuss the factors that determine the type of farming and the type of crops grown in an area. [8]

[Total : 15]

10 For a named crop that is grown locally,

(a) describe the soil preparation needed before sowing or planting; [5]

(b) name **one** common pest of this crop, describe the damage it causes and the ways in which it may be controlled; [4]

(c) explain the importance of record-keeping and outline the records that should be kept for a crop-growing enterprise. [6]

[Total : 15]

11 Chemicals are used to control weeds, pests and disease in crops.

(a) Describe the safety measures that should be taken when handling or storing these chemicals. [10]

(b) Explain the advantages of methods of control that do **not** use chemicals. [5]

[Total : 15]

12 (a) Describe the construction of a fence to enclose a **named** type of livestock, including details of dimensions and materials used. [8]

(b) Explain how the use of fencing, to control grazing, can increase farm productivity. [7]

[Total : 15]

13 (a) For a **named** type of farm livestock,

(i) state the products obtained and their uses,

(ii) describe how **one** of the products is processed or stored before use.

[6]

(b) (i) Outline the ways in which livestock diseases are spread.

(ii) Describe the ways in which the spread of disease in livestock can be prevented and controlled.

[9]

[Total : 15]

